

LM25085A 42V Constant On-Time PFET Buck Switching Controller with 0.9V Reference

Check for Samples: [LM25085A](#)

FEATURES

- Wide 4.5V to 42V Input Voltage Range
- Adjustable Current Limit using $R_{DS(ON)}$ or a Current Sense Resistor
- Programmable Switching Frequency to 1MHz
- No Loop Compensation Required
- Ultra-Fast Transient Response
- Nearly Constant Operating Frequency with Line and Load Variations
- Adjustable Output Voltage from 0.9V
- Precision $\pm 2\%$ Feedback Reference
- Capable of 100% Duty Cycle Operation
- Internal Soft-Start Timer
- Integrated High Voltage Bias Regulator
- Thermal Shutdown

PACKAGE

- HVSSOP-PowerPAD-8
- VSSOP-8
- WSON-8 (3 mm x 3 mm)

DESCRIPTION

The LM25085A is a functional variant of the LM25085 COT PFET Buck Switching Controller. The functional differences of the LM25085A are: The feedback reference voltage is 0.9V, the forced off-time after current limit detection is longer, and the soft-start time is shorter (1.8 ms).

The LM25085A is a high efficiency PFET switching regulator controller that can be used to quickly and easily develop a small, efficient buck regulator for a wide range of applications. This high voltage controller contains a PFET gate driver and a high voltage bias regulator which operates over a wide 4.5V to 42V input range. The constant on-time regulation principle requires no loop compensation, simplifies circuit implementation, and results in ultra-fast load transient response. The operating frequency remains nearly constant with line and load variations due to the inverse relationship between the input voltage and the on-time. The PFET architecture allows 100% duty cycle operation for a low dropout voltage. Either the $R_{DS(ON)}$ of the PFET or an external sense resistor can be used to sense current for over-current detection.

Typical Application, Basic Step Down Controller

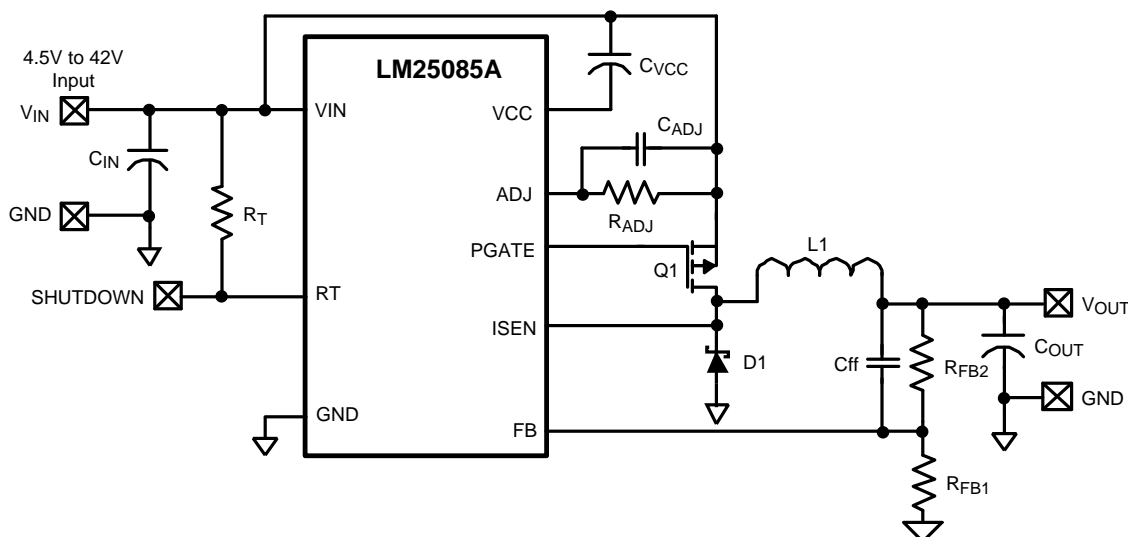

Please be aware that an important notice concerning availability, standard warranty, and use in critical applications of Texas Instruments semiconductor products and disclaimers thereto appears at the end of this data sheet.

All trademarks are the property of their respective owners.

Connection Diagram

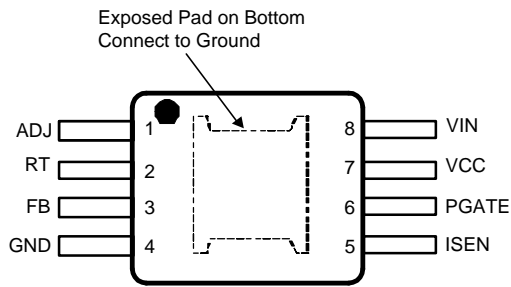

**Figure 1. Top View
8-Lead HVSSOP**

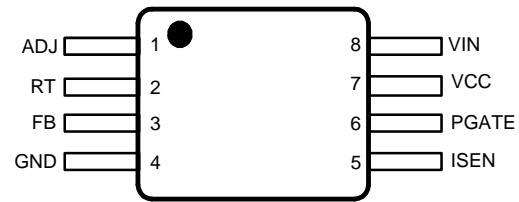

**Figure 2. Top View
8-Lead VSSOP**

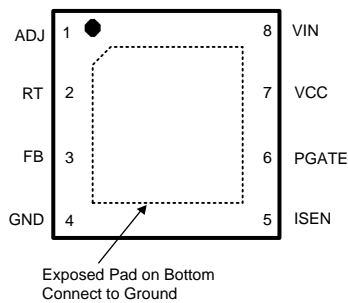

**Figure 3. Top View
8-Lead WSON**

PIN DESCRIPTIONS

Pin No.	Name	Description	Application Information
1	ADJ	Current Limit Adjust	The current limit threshold is set by an external resistor from VIN to ADJ in conjunction with the external sense resistor or the PFET's $R_{DS(ON)}$.
2	RT	On-time control and shutdown	An external resistor from VIN to RT sets the buck switch on-time and switching frequency. Grounding this pin shuts down the controller.
3	FB	Voltage Feedback from the regulated output	Input to the regulation and over-voltage comparators. The regulation level is 0.9V.
4	GND	Circuit Ground	Ground reference for all internal circuitry
5	ISEN	Current sense input for current limit detection.	Connect to the PFET drain when using $R_{DS(ON)}$ current sense. Connect to the PFET source and the sense resistor when using a current sense resistor.
6	PGATE	Gate Driver Output	Connect to the gate of the external PFET.
7	VCC	Output of the gate driver bias regulator	Output of the negative voltage regulator (relative to VIN) that biases the PFET gate driver. A low ESR capacitor is required from VIN to VCC, located as close as possible to the pins.
8	VIN	Input supply voltage	The operating input range is from 4.5V to 42V. A low ESR bypass capacitor must be located as close as possible to the VIN and GND pins.
	EP	Exposed Pad	Exposed pad on the underside of the package (HVSSOP-PowerPAD-8 and WSON only). This pad is to be soldered to the PC board ground plane to aid in heat dissipation.



These devices have limited built-in ESD protection. The leads should be shorted together or the device placed in conductive foam during storage or handling to prevent electrostatic damage to the MOS gates.

Absolute Maximum Ratings ⁽¹⁾⁽²⁾

VIN to GND	-0.3V to 45V
ISEN to GND	-0.3V to $V_{IN} + 0.3V$
ADJ to GND	-0.3V to $V_{IN} + 0.3V$
RT, FB to GND	-0.3V to 7V
VIN to VCC, VIN to PGATE	-0.3V to 10V
ESD Rating ⁽³⁾	
Human Body Model	2kV
Storage Temperature Range	-65°C to +150°C

- (1) Absolute Maximum Ratings are limits beyond which damage to the device may occur. Operating Ratings are conditions under which operation of the device is intended to be functional. For specifications and test conditions, see the Electrical Characteristics.
- (2) If Military/Aerospace specified devices are required, please contact the TI Sales Office/ Distributors for availability and specifications.
- (3) The human body model is a 100 pF capacitor discharged through a 1.5 kΩ resistor into each pin.

Operating Ratings ⁽¹⁾

VIN Voltage	4.5V to 42V
Junction Temperature	-40°C to +125°C

- (1) Absolute Maximum Ratings are limits beyond which damage to the device may occur. Operating Ratings are conditions under which operation of the device is intended to be functional. For specifications and test conditions, see the Electrical Characteristics.

Electrical Characteristics

Limits in standard type are for $T_J = 25^\circ\text{C}$ only; limits in **boldface** type apply over the junction temperature (T_J) range of -40°C to $+125^\circ\text{C}$. Minimum and Maximum limits are specified through test, design, or statistical correlation. Typical values represent the most likely parametric norm at $T_J = 25^\circ\text{C}$, and are provided for reference purposes only. Unless otherwise stated the following conditions apply: $V_{IN} = 24V$, $R_T = 100\text{ k}\Omega$.

Symbol	Parameter	Conditions	Min	Typ	Max	Units
VIN Pin						
I_{IN}	Operating current	Non-switching, FB = 1.05V ⁽¹⁾		1.25	1.75	mA
I_Q	Shutdown current	RT = 0V ⁽¹⁾		175	300	μA
VCC Regulator ⁽²⁾						
$V_{CC(\text{reg})}$	VIN - VCC	Vin = 9V, FB = 1.05V, ICC = 0 mA	6.9	7.7	8.5	V
		Vin = 9V, FB = 1.05V, ICC = 20 mA		7.7		V
		Vin = 42V, FB = 1.05V, ICC = 0 mA		7.7		V
$UVLO_{VCC}$	VCC under-voltage lock-out threshold	V_{CC} increasing		3.8		V
		V_{CC} decreasing		260		mV
$V_{CC(\text{CL})}$	VCC Current Limit	FB = 1.05V	20	40		mA
PGATE Pin						
$V_{PGATE(\text{HI})}$	PGATE High voltage	PGATE Pin = Open	$V_{IN} - 0.1$	V_{IN}		V
$V_{PGATE(\text{LO})}$	PGATE Low voltage	PGATE Pin = Open		V_{CC}	$V_{CC} + 0.1$	V
$V_{PGATE(\text{HI})4.5}$	PGATE High Voltage at Vin = 4.5V	PGATE Pin = Open	$V_{IN} - 0.1$	V_{IN}		V
$V_{PGATE(\text{LO})4.5}$	PGATE Low Voltage at Vin = 4.5V	PGATE Pin = Open		V_{CC}	$V_{CC} + 0.1$	V
I_{PGATE}	Driver Output Source Current	VIN = 12V, PGATE = VIN - 3.5V		1.75		A
	Driver Output Sink Current	VIN = 12V, PGATE = VIN - 3.5V		1.5		A
R_{PGATE}	Driver Output Resistance	Source current = 500 mA		2.3		Ω
		Sink current = 500 mA		2.3		Ω
Current Limit Detection						
I_{ADJ}	ADJUST pin current source	$V_{ADJ} = 22.5V$	32	40	48	μA
$V_{CL\text{ OFFSET}}$	Current limit comparator offset	$V_{ADJ} = 22.5V$, $V_{ADJ} - V_{ISEN}$	-9	0	9	mV

- (1) Operating current and shutdown current do not include the current in the R_T resistor.
- (2) V_{CC} provides self bias for the internal gate drive.

Electrical Characteristics (continued)

Limits in standard type are for $T_J = 25^\circ\text{C}$ only; limits in **boldface** type apply over the junction temperature (T_J) range of -40°C to $+125^\circ\text{C}$. Minimum and Maximum limits are specified through test, design, or statistical correlation. Typical values represent the most likely parametric norm at $T_J = 25^\circ\text{C}$, and are provided for reference purposes only. Unless otherwise stated the following conditions apply: $V_{IN} = 24\text{V}$, $R_T = 100\text{ k}\Omega$.

Symbol	Parameter	Conditions	Min	Typ	Max	Units
RT Pin						
RT_{SD}	Shutdown threshold	RT Pin voltage rising		0.73		V
RT_{HYS}	Shutdown threshold hysteresis			50		mV
On-Time						
t_{ON-1}	On-time	$V_{IN} = 4.5\text{V}$, $R_T = 100\text{ k}\Omega$	3.5	5	7.15	μs
t_{ON-2}		$V_{IN} = 24\text{V}$, $R_T = 100\text{ k}\Omega$	560	720	870	ns
t_{ON-3}		$V_{IN} = 42\text{V}$, $R_T = 100\text{ k}\Omega$	329	415	500	ns
t_{ON-4}	Minimum on-time in current limit ⁽³⁾	$V_{IN} = 24\text{V}$, 25 mV overdrive at ISEN	55	140	235	ns
Off-Time						
$t_{OFF(CL1)}$	Off-time (current limit) ⁽³⁾	$V_{IN} = 12\text{V}$, $V_{FB} = 0\text{V}$	5.56	8	10.96	μs
$t_{OFF(CL2)}$		$V_{IN} = 12\text{V}$, $V_{FB} = 0.75\text{V}$	2.59	3.7	5.16	μs
$t_{OFF(CL3)}$		$V_{IN} = 24\text{V}$, $V_{FB} = 0\text{V}$	9.03	13.2	18.1	μs
$t_{OFF(CL4)}$		$V_{IN} = 24\text{V}$, $V_{FB} = 0.75\text{V}$	4.29	6	8.54	μs
Regulation and Over-Voltage Comparators (FB Pin)						
V_{REF}	FB regulation threshold		0.882	0.9	0.918	V
V_{OV}	FB over-voltage threshold	Measured with respect to V_{REF}		350		mV
I_{FB}	FB bias current			10		nA
Soft-Start Function						
t_{SS}	Soft-start time		1.16	1.8	3.15	ms
Thermal Shutdown						
T_{SD}	Junction shutdown temperature	Junction temperature rising		170		$^\circ\text{C}$
T_{HYS}	Junction shutdown hysteresis			20		$^\circ\text{C}$
Thermal Resistance⁽⁴⁾						
θ_{JA}	Junction to ambient, 0 LFPM air flow ⁽⁵⁾	VSSOP-8 package		126		$^\circ\text{C/W}$
		HVSSOP-PowerPAD-8 package		46		
		WSON-8 package		54		
θ_{JC}	Junction to case, 0 LFPM air flow ⁽⁵⁾	VSSOP-8 package		29		$^\circ\text{C/W}$
		HVSSOP-PowerPAD-8 package		5.5		
		WSON-8 package		9.1		

- (3) The tolerance of the minimum on-time (t_{ON-4}) and the current limit off-times ($t_{OFF(CL1)}$ through ($t_{OFF(CL4)}$) track each other over process and temperature variations. A device which has an on-time at the high end of the range will have an off-time that is at the high end of its range.
- (4) For detailed information on soldering plastic VSSOP and WSON packages visit www.ti.com/packaging.
- (5) Tested on a 4 layer JEDEC board. Four vias provided under the exposed pad. See JEDEC standards JESD51-5 and JESD51-7.

Typical Performance Characteristics

Unless otherwise specified the following conditions apply: $T_J = 25^\circ\text{C}$, $V_{IN} = 24\text{V}$.

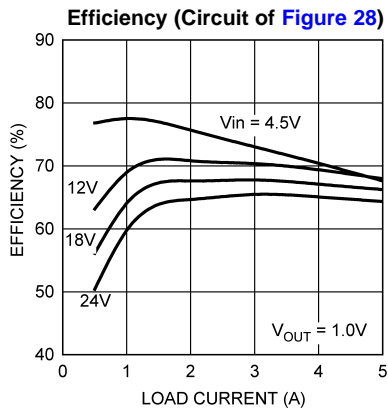

Figure 4.

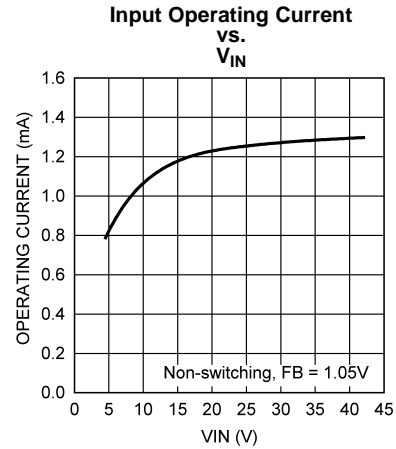

Figure 5.

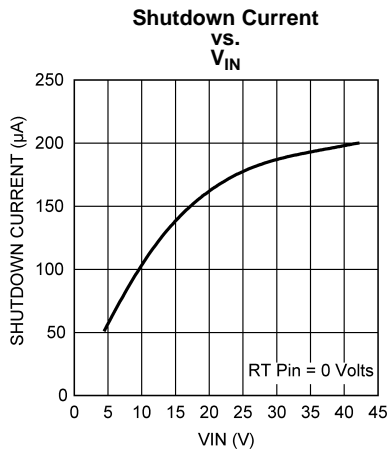

Figure 6.

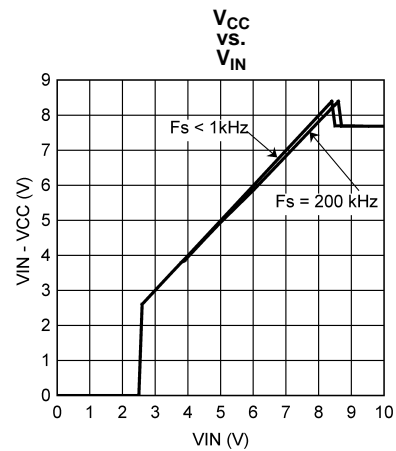

Figure 7.

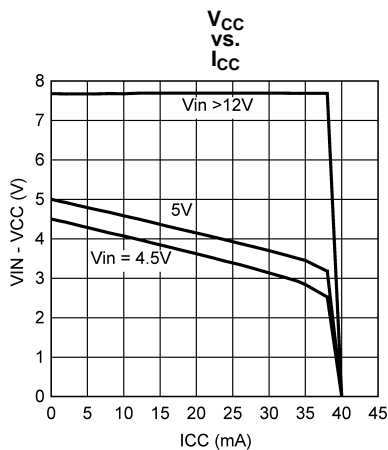

Figure 8.

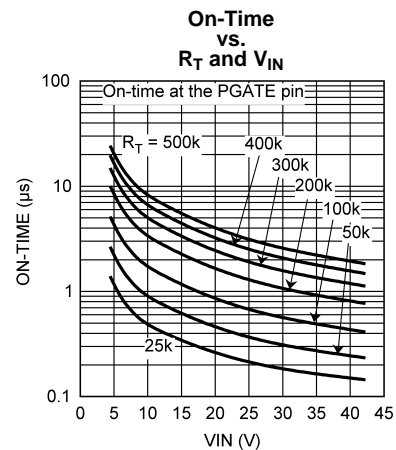

Figure 9.

Typical Performance Characteristics (continued)

Unless otherwise specified the following conditions apply: $T_J = 25^\circ\text{C}$, $V_{IN} = 24\text{V}$.

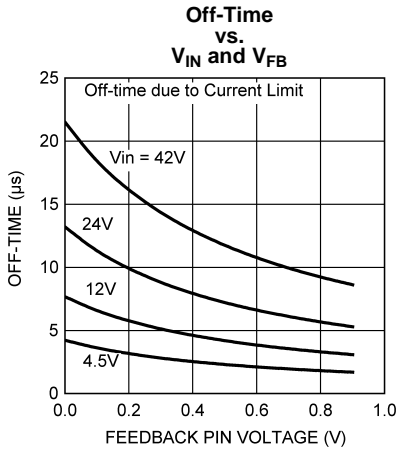

Figure 10.

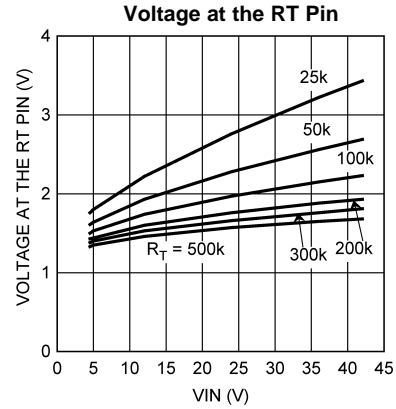

Figure 11.

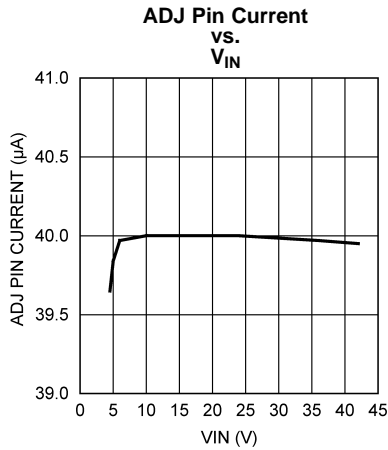

Figure 12.

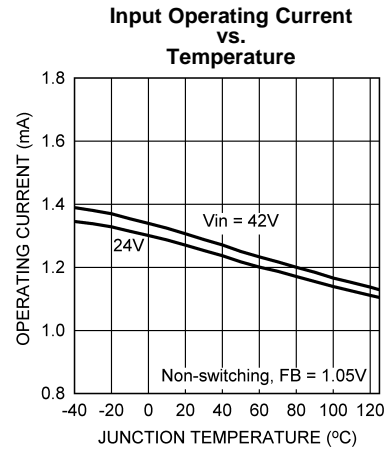

Figure 13.

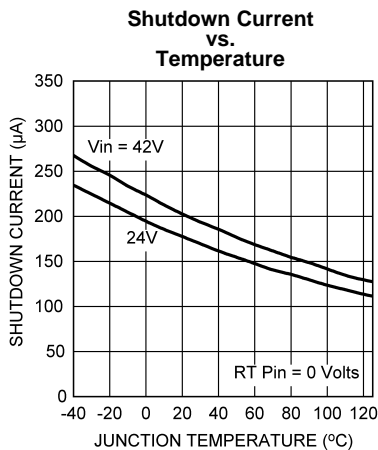

Figure 14.

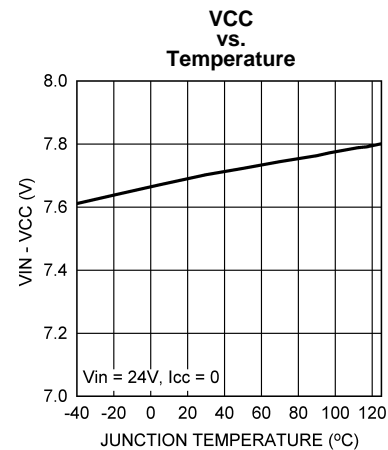

Figure 15.

Typical Performance Characteristics (continued)

Unless otherwise specified the following conditions apply: $T_J = 25^\circ\text{C}$, $V_{IN} = 24\text{V}$.

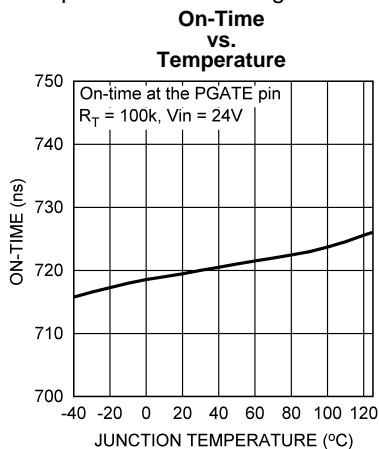

Figure 16.

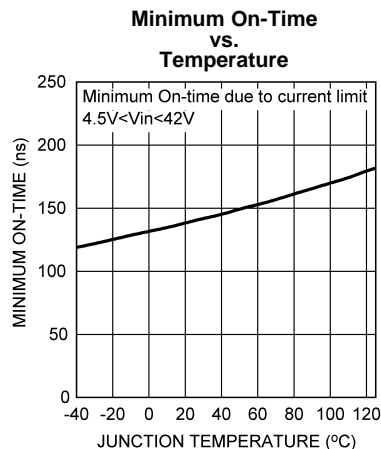

Figure 17.

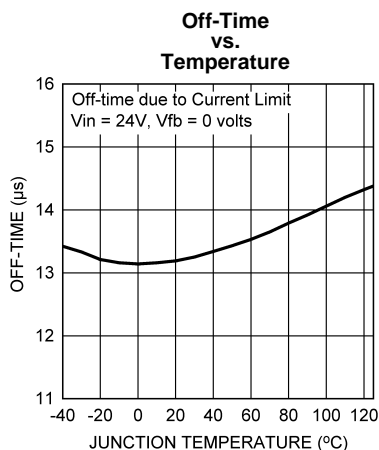

Figure 18.

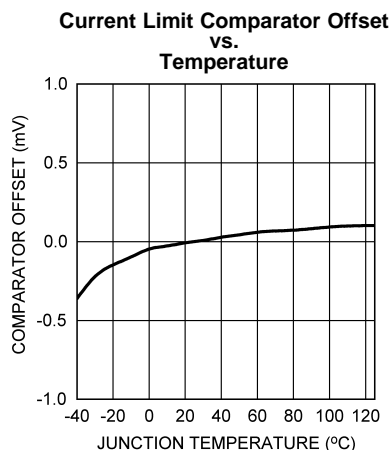

Figure 19.

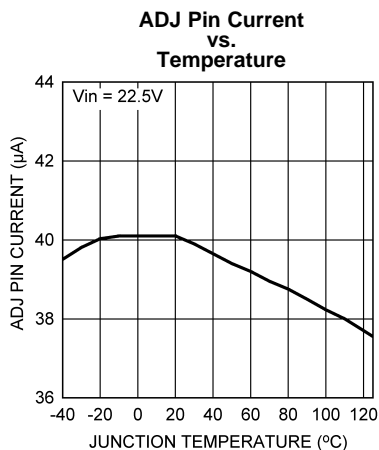

Figure 20.

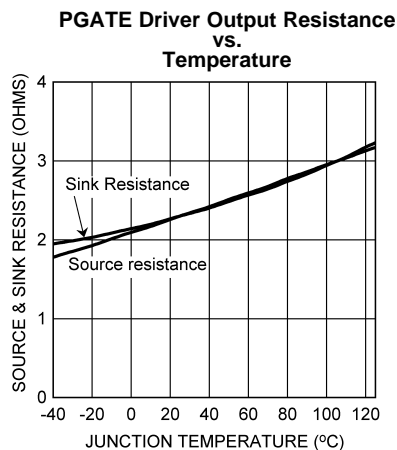

Figure 21.

Typical Performance Characteristics (continued)

Unless otherwise specified the following conditions apply: $T_J = 25^\circ\text{C}$, $V_{IN} = 24\text{V}$.

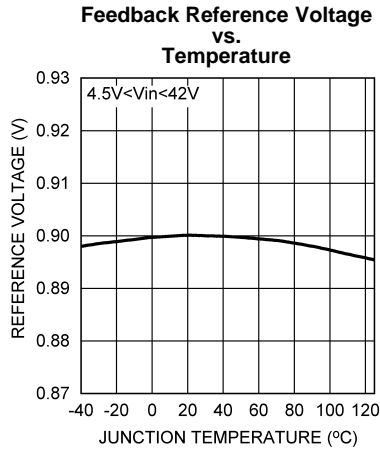

Figure 22.

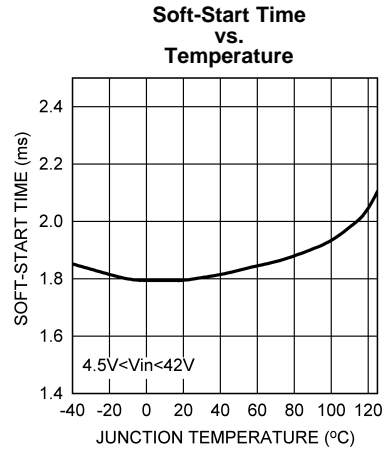

Figure 23.

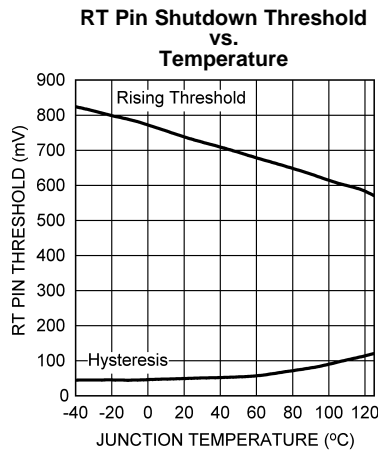
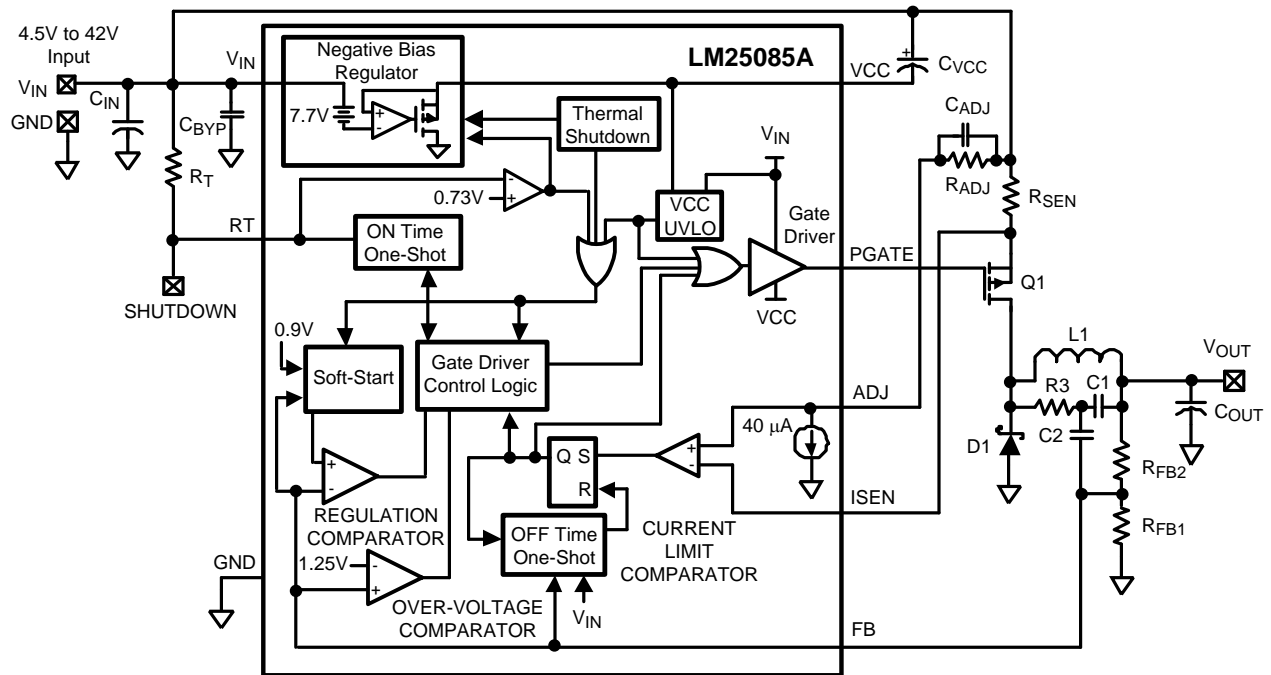

Figure 24.

Block Diagram



Sense resistor method shown for current limit detection.
Minimum output ripple configuration shown.

FUNCTIONAL DESCRIPTION

OVERVIEW

The LM25085A is a PFET buck (step-down) DC-DC controller using the constant on-time (COT) control principle. The input operating voltage range of the LM25085A is 4.5V to 42V. The use of a PFET in a buck regulator greatly simplifies the gate drive requirements and allows for 100% duty cycle operation to extend the regulation range when operating at low input voltage. However, PFET transistors typically have higher on-resistance and gate charge when compared to similarly rated NFET transistors. Consideration of available PFETs, input voltage range, gate drive capability of the LM25085A, and thermal resistances indicate an upper limit of 10A for the load current for LM25085A applications. Constant on-time control is implemented using an on-time one-shot that is triggered by the feedback signal. During the off-time, when the PFET (Q1) is off, the load current is supplied by the inductor and the output capacitor. As the output voltage falls, the voltage at the feedback comparator input (FB) falls below the regulation threshold. When this occurs Q1 is turned on for the one-shot period which is determined by the input voltage (V_{IN}) and the R_T resistor. During the on-time the increasing inductor current increases the voltage at FB above the feedback comparator threshold. For a buck regulator the basic relationship between the on-time, off-time, input voltage and output voltage is:

$$\text{Duty Cycle} = \frac{V_{OUT}}{V_{IN}} = \frac{t_{ON}}{t_{ON} + t_{OFF}} = t_{ON} \times F_s \quad (1)$$

where F_s is the switching frequency. Equation 1 is valid only in continuous conduction mode (inductor current does not reach zero). Since the LM25085A controls the on-time inversely proportional to V_{IN} , the switching frequency remains relatively constant as V_{IN} is varied. If the input voltage falls to a level that is equal to or less than the regulated output voltage Q1 is held on continuously (100% duty cycle) and V_{OUT} is approximately equal to V_{IN} .

The COT control scheme, with the feedback signal applied to a comparator rather than an error amplifier, requires no loop compensation, resulting in very fast load transient response.

The LM25085A is available in both an 8 pin HVSSOP-PowerPAD package and an 8 pin WSON package with an exposed pad to aid in heat dissipation. An 8 pin VSSOP package without an exposed pad is also available.

REGULATION CONTROL CIRCUIT

The LM25085A buck DC-DC controller employs a control scheme based on a comparator and a one-shot on-timer, with the output voltage feedback compared to an internal reference voltage (0.9V). When the FB pin voltage falls below the feedback reference, Q1 is switched on for a time period determined by the input voltage and a programming resistor (R_T). Following the on-time Q1 remains off until the FB voltage falls below the reference. Q1 is then switched on for another on-time period. The output voltage is set by the feedback resistors (R_{FB1} , R_{FB2} in Block Diagram). The regulated output voltage is calculated as follows:

$$V_{OUT} = 0.9V \times (R_{FB2} + R_{FB1}) / R_{FB1} \quad (2)$$

The feedback voltage supplied to the FB pin is applied to a comparator rather than a linear amplifier. For proper operation sufficient ripple amplitude is necessary at the FB pin to switch the comparator at regular intervals with minimum delay and noise susceptibility. This ripple is normally obtained from the output voltage ripple attenuated through the feedback resistors. The output voltage ripple is a result of the inductor's ripple current passing through the output capacitor's ESR, or through a resistor in series with the output capacitor. Multiple methods are available to ensure sufficient ripple is supplied to the FB pin, and three different configurations are discussed in Applications Information.

When in regulation, the LM25085A operates in continuous conduction mode at medium to heavy load currents and discontinuous conduction mode at light load currents. In continuous conduction mode the inductor's current is always greater than zero, and the operating frequency remains relatively constant with load and line variations. The minimum load current for continuous conduction mode is one-half the inductor's ripple current amplitude. In discontinuous conduction mode, where the inductor's current reaches zero during the off-time, the operating frequency is lower than in continuous conduction mode and varies with load current. Conversion efficiency is maintained at light loads since the switching losses are reduced with the reduction in load and frequency.

If the voltage at the FB pin exceeds 1.25V due to a transient overshoot or excessive ripple at V_{OUT} the internal over-voltage comparator immediately switches off Q1. The next on-time period starts when the voltage at FB falls below the feedback reference voltage.

ON-TIME TIMER

The on-time of the PFET gate drive output (PGATE pin) is determined by the resistor (R_T) and the input voltage (V_{IN}), and is calculated from:

$$t_{ON} = \frac{1.45 \times 10^{-7} \times (R_T + 1.4)}{(V_{IN} - 1.56V + R_T/3167)} + 50 \text{ ns} \quad (3)$$

where R_T is in k Ω . The minimum on-time, which occurs at maximum V_{IN} , should not be set less than 150 ns (see [CURRENT LIMITING](#)). The buck regulator effective on-time, measured at the SW node (junction of Q1, L1, and D1) is typically longer than that calculated in [Equation 3](#) due to the asymmetric delay of the PFET. The on-time difference caused by the PFET switching delay can be estimated as the difference of the turn-off and turn-on delays listed in the PFET data sheet. Measuring the difference between the on-time at the PGATE pin versus the SW node in the actual application circuit is also recommended.

In continuous conduction mode, the inverse relationship of t_{ON} with V_{IN} results in a nearly constant switching frequency as V_{IN} is varied. The operating frequency can be calculated from:

$$F_S = \frac{V_{OUT} \times (V_{IN} - 1.56V + R_T/3167)}{V_{IN} \times [(1.45 \times 10^{-7} \times (R_T + 1.4)) + (t_D \times (V_{IN} - 1.56V + R_T/3167))]} \quad (4)$$

where R_T is in k Ω , and t_D is equal to 50 ns plus the PFET's delay difference. To set a specific continuous conduction mode switching frequency (F_S), the R_T resistor is determined from the following:

$$R_T = \frac{V_{OUT} \times (V_{IN} - 1.56V)}{1.45 \times 10^{-7} \times V_{IN} \times F_S} - \frac{t_D \times (V_{IN} - 1.56V)}{1.45 \times 10^{-7}} - 1.4 \quad (5)$$

where R_T is in k Ω . A simplified version of [Equation 6](#) at $V_{IN} = 12V$, and $t_D = 100 \text{ ns}$, is:

$$R_T = \frac{V_{OUT} \times 6 \times 10^6}{F_S} - 8.6$$

For $V_{IN} = 42V$ and $t_D = 100 \text{ ns}$, the simplified equation is:

$$R_T = \frac{V_{OUT} \times 6.64 \times 10^6}{F_S} - 29.3$$

SHUTDOWN

The LM25085A can be shutdown by grounding the RT pin (see [Figure 25](#)). In this mode the PFET is held off, and the VCC regulator is disabled. The internal operating current is reduced to the value shown in the graph "Shutdown current vs. V_{IN} ". The shutdown threshold at the RT pin is $\approx 0.73V$, with $\approx 50 \text{ mV}$ of hysteresis. Releasing the pin enables normal operation. The RT pin must not be forced high during normal operation.

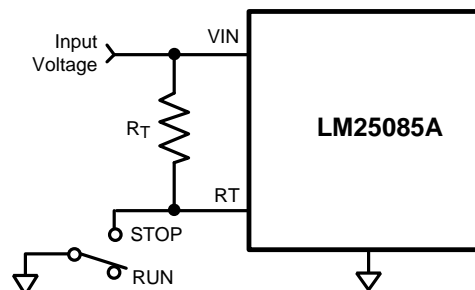

Figure 25. Shutdown Implementation

CURRENT LIMITING

The LM25085A current limiting operates by sensing the voltage across either the $R_{DS(ON)}$ of Q1, or a sense resistor, during the on-time and comparing it to the voltage across the resistor R_{ADJ} (see [Figure 26](#)). The current limit function is much more accurate and stable over temperature when a sense resistor is used. The $R_{DS(ON)}$ of a MOSFET has a wide process variation and a large temperature coefficient.

If the voltage across $R_{DS(ON)}$ of Q1, or the sense resistor, is greater than the voltage across R_{ADJ} , the current limit comparator switches to turn off Q1. Current sensing is disabled for a blanking time of ≈ 100 ns at the beginning of the on-time to prevent false triggering of the current limit comparator due to leading edge current spikes. Because of the blanking time and the turn-on and turn-off delays created by the PFET, the on-time at the PGATE pin should not be set less than 150 ns. An on-time shorter than that may prevent the current limit detection circuit from properly detecting an over-current condition. The duration of the subsequent forced off-time is a function of the input voltage and the voltage at the FB pin, as shown in [Figure 10](#). The longer-than-normal forced off-time allows the inductor current to decrease to a low level before the next on-time. This cycle-by-cycle monitoring, followed by a forced off-time, provides effective protection from output load faults over a wide range of operating conditions.

The voltage across the R_{ADJ} resistor is set by an internal 40 μ A current sink at the ADJ pin. When using Q1's $R_{DS(ON)}$ for sensing, the current at which the current limit comparator switches is calculated from:

$$I_{CL} = 40 \mu\text{A} \times R_{ADJ}/R_{DS(ON)} \quad (6)$$

When using a sense resistor (R_{SEN}) the threshold of the current limit comparator is calculated from:

$$I_{CL} = 40 \mu\text{A} \times R_{ADJ}/R_{SEN} \quad (7)$$

When using [Equation 6](#) or [Equation 7](#), the tolerances for the ADJ pin current sink and the offset of the current limit comparator should be included to ensure the resulting minimum current limit is not less than the required maximum switch current. Simultaneously increasing the values of R_{ADJ} and R_{SEN} decreases the effects of the current limit comparator offset, but at the expense of higher power dissipation. When using a sense resistor, the R_{SEN} resistor value should be chosen within the practical limitations of power dissipation and physical size. For example, for a 10A current limit, setting $R_{SEN} = 0.005\Omega$ results in a power dissipation as high as 0.5W. Current sense connections to the R_{SEN} resistor, or to Q1, must be Kelvin connections to ensure accuracy.

The C_{ADJ} capacitor filters noise from the ADJ pin, and helps prevent unintended switching of the current limit comparator due to input voltage transients. The recommended value for C_{ADJ} is 1000 pF.

CURRENT LIMIT OFF-TIME

When the current through Q1 exceeds the current limit threshold, the LM25085A forces an off-time longer than the normal off-time defined by [Equation 1](#). See [Figure 10](#), or calculate the current limit off-time from the following equation:

$$t_{OFF(CL)} = \frac{8 \times 10^{-6} \times ((V_{IN}/31) + 0.15)}{(V_{FB} \times 0.93) + 0.56\text{V}} \quad (8)$$

where V_{IN} is the input voltage, and V_{FB} is the voltage at the FB pin at the time current limit was detected. This feature is necessary to allow the inductor current to decrease sufficiently to offset the current increase which occurred during the on-time. During the on-time, the inductor current increases an amount equal to:

$$\Delta I = \frac{(V_{IN} - V_{OUT}) \times t_{ON}}{L} \quad (9)$$

During the off-time the inductor current decreases due to the reverse voltage applied across the inductor by the output voltage, the freewheeling diode's forward voltage (V_{FD}), and the voltage drop due to the inductor's series resistance (V_{ESR}). The current decrease is equal to:

$$\Delta I = \frac{(V_{OUT} + V_{FD} + V_{ESR}) \times t_{OFF}}{L} \quad (10)$$

The on-time in Equation 9 is shorter than the normal on-time since the PFET is shut off when the current limit threshold is crossed. If the off-time is not long enough, such that the current decrease (Equation 10) is less than the current increase (Equation 9), the current levels are higher at the start of the next on-time. This results in a further decrease in on-time, since the current limit threshold is crossed sooner. A balance is reached when the current changes in Equation 9 and Equation 10 are equal. The worst case situation is that of a direct short circuit at the output terminals, where $V_{OUT} = 0$ volts, as that results in the largest current increase during the on-time, and the smallest decrease during the off-time. The sum of the diode's forward voltage and the inductor's ESR voltage must be sufficient to ensure current runaway does not occur. Using Equation 9 and Equation 10, this requirement can be stated as:

$$V_{FD} + V_{ESR} \geq \frac{V_{IN} \times t_{ON}}{t_{OFF}} \quad (11)$$

For t_{ON} in Equation 11 use the minimum on-time at the SW node. To determine this time period add the "Minimum on-time in current limit" specified in Electrical Characteristics (t_{ON-4}) to the difference of the turn-off and turn-on delays of the PFET. For t_{OFF} use the value in Figure 10, or use Equation 8, where V_{FB} is equal to zero volts. When using the minimum or maximum limits of those specifications to determine worst case situations, the tolerance of the minimum on-time (t_{ON-4}) and the current limit off-times ($t_{OFF(CL1)}$ through $t_{OFF(CL4)}$) track each other over the process and temperature variations. A device which has an on-time at the high end of the range will have an off-time that is at the high end of its range.

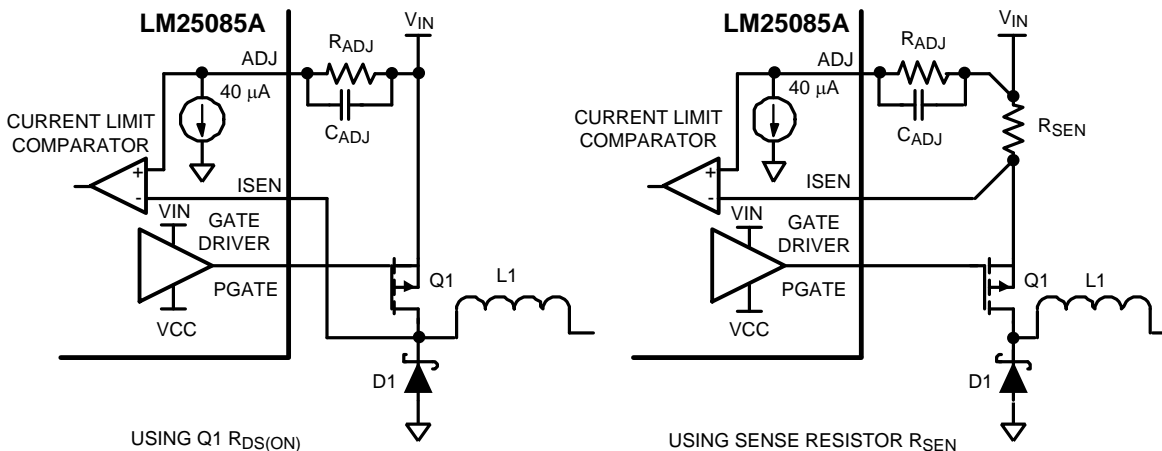

Figure 26. Current Limit Sensing

VCC REGULATOR

The VCC regulator provides a regulated voltage between the VIN and the VCC pins to provide the bias and gate current for the PFET gate driver. The 0.47 µF capacitor at the VCC pin must be a low ESR capacitor, preferably ceramic as it provides the high surge current for the PFET's gate at each turn-on. The capacitor must be located as close as possible to the VIN and VCC pins to minimize inductance in the PC board traces.

Referring to the Figure 7, the voltage across the VCC regulator ($V_{IN} - V_{CC}$) is equal to V_{IN} until V_{IN} reaches approximately 8.5V. At higher values of V_{IN} , the voltage at the VCC pin is regulated at approximately 7.7V below V_{IN} . The VCC regulator has a maximum current capability of at least 20 mA. The regulator is disabled when the LM25085A is shutdown using the RT pin, or when the thermal shutdown is activated.

PGATE DRIVER OUTPUT

The PGATE pin output swings between V_{IN} (Q1 off) and the VCC pin voltage (Q1 on). The rise and fall times depend on the PFET gate capacitance and the source and sink currents provided by the internal gate driver. See Electrical Characteristics for the current capability of the driver.

P-CHANNEL MOSFET SELECTION

The PFET must be rated for the maximum input voltage, with some margin above that to allow for transients and ringing which can occur on the supply line and the switching node. The gate-to-source voltage (V_{GS}) normally provided to the PFET is 7.7 volts for V_{IN} greater than 8.5V. However, if the circuit is to be operated at lower values of V_{IN} , the selected PFET must be able to fully turn-on with a V_{GS} voltage equal to V_{IN} . The minimum input operating voltage for the LM25085A is 4.5V.

Similar to NFETs, the case or exposed thermal pad for a PFET is electrically connected to the drain terminal. When designing a PFET buck regulator the drain terminal is connected to the switching node. This situation requires a trade-off between thermal and EMI performance since increasing the PC board area of the switching node to aid the PFET power dissipation also increases radiated noise, possibly disrupting the circuit operation. Typically the switching node area is kept to a reasonable minimum and the PFET peak current is derated to stay within the recommended temperature rating of the PFET. The $R_{DS(ON)}$ of the PFET determines a portion of the power dissipation in the PFET. However, PFETs with very low $R_{DS(ON)}$ usually have large values of gate charge. A PFET with a higher gate charge has a corresponding slower switching speed, leading to higher switching losses and affecting the PFET power dissipation.

If the PFET $R_{DS(ON)}$ is used for current limit detection, note that it typically has a positive temperature coefficient. At 100°C the $R_{DS(ON)}$ may be as much as 50% higher than the value at 25°C which could result in incorrect current limiting if not accounted for when determining the value of the R_{ADJ} resistor. The PFET Total Gate Charge determines most of the power dissipation in the LM25085A due to the repetitive charge and discharge of the PFET's gate capacitance by the gate driver (powered from the VCC regulator). The LM25085A's internal power dissipation can be calculated from the following:

$$P_{DISS} = V_{IN} \times ((Q_G \times F_S) + I_{IN}) \quad (12)$$

where Q_G is the PFET's Total Gate Charge obtained from its datasheet, F_S is the switching frequency, and I_{IN} is the LM25085A's operating current obtained from [Figure 5](#). Using the Thermal Resistance specifications in the [Electrical Characteristics](#), the approximate junction temperature can be determined. If the calculated junction temperature is near the maximum operating temperature of 125°C, either the switching frequency must be reduced, or a PFET with a smaller Total Gate Charge must be used.

SOFT-START

The internal soft-start feature of the LM25085A allows the regulator to gradually reach a steady state operating point at power up, thereby reducing startup stresses and current surges. Upon turn-on, when V_{CC} reaches its under-voltage lockout threshold, the internal soft-start circuit ramps the feedback reference voltage from 0V to 0.9V, causing V_{OUT} to ramp up in a proportional manner. The soft-start ramp time is typically 1.8 ms.

In addition to controlling the initial power up cycle, the soft-start circuit also activates when the LM25085A is enabled by releasing the RT pin, and when the circuit is shutdown and restarted by the internal Thermal Shutdown circuit.

If the voltage at FB is below the regulation threshold value due to an over-current condition or a short circuit at V_{out} , the internal reference voltage provided by the soft-start circuit to the regulation comparator is reduced along with FB. When the over-current or short circuit condition is removed, V_{OUT} returns to the regulated value at a rate determined by the soft-start ramp. This feature helps prevent the output voltage from over-shooting following an overload event.

THERMAL SHUTDOWN

The LM25085A should be operated such that the junction temperature does not exceed 125°C. If the junction temperature increases above that, an internal Thermal Shutdown circuit activates at 170°C (typical) to disable the VCC regulator and the gate driver, and discharge the soft-start capacitor. This feature helps prevent catastrophic failures from accidental device overheating. When the junction temperature falls below 150°C (typical hysteresis = 20°C), the gate driver is enabled, the soft-start circuit is released, and normal operation resumes.

Applications Information

EXTERNAL COMPONENTS

The procedure for calculating the external components is illustrated with the following design example. Referring to [Block Diagram](#), the circuit is to be configured for the following specifications:

- $V_{OUT} = 1.0V$
- $V_{IN} = 4.5V$ to $24V$, 12V Nominal
- Maximum load current ($I_{OUT(max)}$) = 5A
- Minimum load current ($I_{OUT(min)}$) = 500 mA (for continuous conduction mode)
- Switching Frequency (F_{SW}) = 200 kHz
- Maximum allowable output ripple (V_{OS}) = 10 mVp-p
- Selected PFET: Vishay Si7465
- **R_{FB1} and R_{FB2} :** These resistors set the output voltage. The ratio of these resistors is calculated from:

$$R_{FB2}/R_{FB1} = (V_{OUT}/0.9V) - 1$$

For this example, $R_{FB2} / R_{FB1} = 0.111$. Typically, R_{FB1} and R_{FB2} should be chosen from standard value resistors in the range of 1 k Ω to 20 k Ω which satisfy the above ratio. For this example, $R_{FB2} = 1.1$ k Ω , and $R_{FB1} = 10$ k Ω .

R_T , PFET: Before selecting the R_T resistor, the PFET must be selected as its turn-on and turn-off delays affect the calculated value of R_T . For the Vishay Si7465 PFET, the difference of its typical turn-off and turn-on delays is 57 ns. Using [Equation 5](#) at nominal input voltage, R_T calculates to be:

$$R_T = \frac{1 \times (12 - 1.56V)}{1.45 \times 10^{-7} \times 12 \times 200 \text{ kHz}} - \frac{(50 \text{ ns} + 57 \text{ ns}) \times (12 - 1.56V)}{1.45 \times 10^{-7}} - 1.4 = 20.9$$

A standard value 21 k Ω resistor is selected. Using [Equation 3](#) the minimum on-time at the PGATE pin, which occurs at maximum input voltage (24V), is calculated to be 195 ns. This minimum one-shot period is sufficiently longer than the minimum recommended value of 150 ns. The minimum on-time at the SW node is longer due to the delay added by the PFET (57 ns). Therefore the minimum SW node on-time is 252 ns at 24V. At the SW node the maximum on-time is calculated to be 1.21 μ s at 4.5V.

- **L1:** The main parameter controlled by the inductor value is the current ripple amplitude (I_{OR}). See [Figure 27](#). The minimum load current for continuous conduction mode is used to determine the maximum allowable ripple such that the inductor current's lower peak does not fall below 0 mA. Continuous conduction mode operation at minimum load current is not a requirement of the LM25085A, but serves as a guideline for selecting L1. For this example, the maximum ripple current is:

$$I_{OR(max)} = 2 \times I_{OUT(min)} = 1.0 \text{ Amp} \tag{13}$$

If an application's minimum load current is zero, a good initial estimate for the maximum ripple current ($I_{OR(max)}$) is 20% of the maximum load current. The ripple calculated in [Equation 13](#) is then used in the following equation to calculate L1:

$$L1 = \frac{t_{ON(min)} \times (V_{IN(max)} - V_{OUT})}{I_{OR(max)}} = 5.79 \mu\text{H} \tag{14}$$

A standard value 6.8 μ H inductor is selected. Using this inductance value, the maximum ripple current amplitude, which occurs at maximum input voltage, calculates to 0.85 Ap-p. The peak current (I_{PK}) at maximum load current is 5.43A. However, the current rating of the selected inductor must be based on the maximum current limit value calculated below.

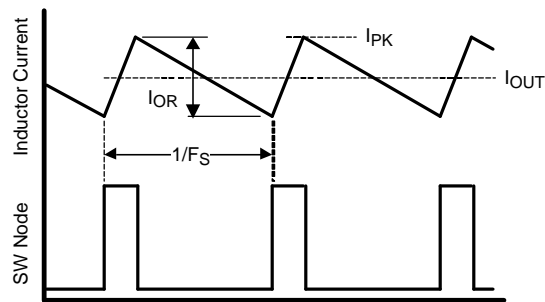

Figure 27. Inductor Current Waveform

- **R_{SEN}, R_{ADJ}:** To achieve good current limit accuracy and avoid over designing the power stage components, the sense resistor method is used for current limiting in this example. A standard value 10 mΩ resistor is selected for R_{SEN}, resulting in a 50 mV drop at maximum load current, and a maximum 0.25W power dissipation in the resistor. Since the LM25085A uses peak current detection, the minimum value for the current limit threshold must be equal to the maximum load current (5A) plus half the maximum ripple amplitude calculated above:

$$I_{CL(min)} = 5A + 0.85A/2 = 5.43A$$

At this current level the voltage across R_{SEN} is 54.3 mV. Adding the current limit comparator offset of 9 mV (max) increases the required current limit threshold to 6.33A. Using Equation 7 with the minimum value for the ADJ pin current (32 μA), the required R_{ADJ} resistor calculates to:

$$R_{ADJ} = \frac{6.33A \times 0.01\Omega}{32 \mu A} = 1.98 \text{ k}\Omega$$

A standard value 2.05 kΩ resistor is selected. The nominal current limit threshold calculates to:

$$I_{CL(nom)} = \frac{(2.05 \text{ k}\Omega \times 40 \mu A)}{0.01\Omega} = 8.2A$$

Using the tolerances for the ADJ pin current and the current limit comparator offset, the maximum current limit threshold calculates to:

$$I_{CL(max)} = \frac{(2.05 \text{ k}\Omega \times 48 \mu A) + 9 \text{ mV}}{0.01\Omega} = 10.7A$$

The minimum current limit thresholds calculate to:

$$I_{CL(min)} = \frac{(2.05 \text{ k}\Omega \times 32 \mu A) - 9 \text{ mV}}{0.01\Omega} = 5.66A$$

The load current in each case is equal to the current limit threshold minus half the current ripple amplitude. The recommended value of 1000 pF for C_{ADJ} is used in this example.

- **C_{OUT}:** Since the maximum allowed output ripple voltage is very low in this example (10 mVp-p), the minimum ripple configuration (R3, C1, and C2 in the Block Diagram) must be used. The resulting ripple at V_{OUT} is then due to the inductor's ripple current passing through C_{OUT}. This capacitor's value can be selected based on the maximum allowable ripple voltage at V_{OUT}, or based on transient response requirements. The following calculation, based on ripple voltage, provides a first order result for the value of C_{OUT}:

$$C_{OUT} = \frac{I_{OR(max)}}{8 \times F_S \times V_{RIPPLE}}$$

where I_{OR(max)} is the maximum ripple current calculated above, and V_{RIPPLE} is the allowable ripple at V_{OUT}.

$$C_{OUT} = \frac{0.85A}{8 \times 200 \text{ kHz} \times 0.01V} = 53.1 \mu F$$

A 68 μF capacitor is selected. Typically the ripple amplitude will be higher than the calculations indicate due to the capacitor's ESR.

- **R3, C1, C2:** The minimum ripple configuration uses these three components to generate the ripple voltage required at the FB pin since there is insufficient ripple at V_{OUT}. A minimum of 25 mVp-p must be applied to the FB pin to obtain stable constant frequency operation. R3 and C1 are selected to generate a sawtooth waveform at their junction, and that waveform is AC coupled to the FB pin via C2. The values of the three

components are determined using the following procedure:

$$\text{Calculate } V_A = V_{\text{OUT}} - (V_{\text{SW}} \times (1 - (V_{\text{OUT}}/V_{\text{IN}(\text{min})})))$$

where V_{SW} is the absolute value of the voltage at the SW node during the off-time, typically 0.5V to 1V depending on the diode D1. Using a typical value of 0.65V, V_A calculates to 0.49V. V_A is the nominal DC voltage at the R3/C1 junction, and is used in the next equation:

$$R3 \times C1 = \frac{(V_{\text{IN}(\text{min})} - V_A) \times t_{\text{ON}}}{\Delta V}$$

where t_{ON} is the maximum on-time (at minimum input voltage), and ΔV is the desired ripple amplitude at the R3/C1 junction, typically 30 mVp-p. For this example

$$R3 \times C1 = \frac{(4.5\text{V} - 0.49\text{V}) \times 1.21 \mu\text{s}}{0.03\text{V}} = 1.62 \times 10^{-4}$$

R3 and C1 are then selected from standard value components to produce the product calculated above. Typical values for C1 are 3000 pF to 10,000 pF, and R3 is typically from 10 k Ω to 300 k Ω . C2 is then chosen large compared to C1, typically 0.1 μF . For this example, 3300 pF is chosen for C1, requiring R3 to be 48.9 k Ω . A standard value 48.7 k Ω resistor is selected.

- **C_{IN} , C_{BYP} :** These capacitors limit the voltage ripple at VIN by supplying most of the switch current during the on-time. At maximum load current, when Q1 is switched on, the current through Q1 suddenly increases to the lower peak of the inductor's ripple current, then ramps up to the upper peak, and then drops to zero at turn-off. The average current during the on-time is the load current. For a worst case calculation, these capacitors must supply this average load current during the maximum on-time, while limiting the voltage drop at VIN. For this example, 0.25V is selected as the maximum allowable droop at VIN. Their minimum value is calculated from:

$$C_{\text{IN}} + C_{\text{BYP}} = \frac{I_{\text{OUT}(\text{max})} \times t_{\text{ON}(\text{max})}}{\Delta V} = \frac{5\text{A} \times 1.21 \mu\text{s}}{0.25\text{V}} = 24.2 \mu\text{F}$$

A 33 μF electrolytic capacitor is selected for C_{IN} , and a 1 μF ceramic capacitor is selected for C_{BYP} . Due to the ESR of C_{IN} , the ripple at VIN will likely be higher than the calculation indicates, and therefore it may be desirable to increase C_{IN} to 47 μF or 68 μF . C_{BYP} must be located as close as possible to the VIN and GND pins of the LM25085A. The voltage rating for both capacitors must be at least 24V. The RMS ripple current rating for the input capacitors must also be considered. A good approximation for the required ripple current rating is $I_{\text{RMS}} > I_{\text{OUT}}/2$.

- **D1:** A Schottky diode is recommended. Ultra-fast recovery diodes are not recommended as the high speed transitions at the SW pin may affect the regulator's operation due to the diode's reverse recovery transients. The diode must be rated for the maximum input voltage, and the worst case current limit level. The average power dissipation in the diode is calculated from:

$$P_{\text{D1}} = V_F \times I_{\text{OUT}} \times (1-D)$$

where V_F is the diode's forward voltage drop, and D is the on-time duty cycle. Using [Equation 1](#), the minimum duty cycle occurs at maximum input voltage, and is calculated to be $\approx 4.2\%$ in this example. The diode power dissipation calculates to be:

$$P_{\text{D1}} = 0.65\text{V} \times 5\text{A} \times (1 - 0.042) = 3.11\text{W}$$

- **C_{VCC} :** The capacitor at the VCC pin (from VIN to VCC) provides not only noise filtering and stability for the VCC regulator, but also provides the surge current for the PFET gate drive. The typical recommended value for C_{VCC} is 0.47 μF . A good quality, low ESR, ceramic capacitor is recommended. C_{VCC} must be located as close as possible to the VIN and VCC pins. If the selected PFET has a Total Gate Charge specification of 100 nC or larger, or if the circuit is required to operate at input voltages below 7 volts, a larger capacitor may be required. The maximum recommended value for C_{VCC} is 1 μF .
- **IC Power Dissipation:** The maximum power dissipated in the LM25085A package is calculated using [Equation 12](#) at the maximum input voltage. The Total Gate Charge for the Si7465 PFET is specified to be 40 nC (max) in its data sheet. Therefore the total power dissipation within the LM25085A is calculated to be:

$$P_{\text{DISS}} = 24\text{V} \times ((40 \text{ nC} \times 200 \text{ kHz}) + 1.25 \text{ mA}) = 222 \text{ mW}$$

Using an HVSSOP-PowerPAD-8 package with a θ_{JA} of 46°C/W produces a temperature rise of 10°C from junction to ambient.

Final Design Example Circuit

The final circuit is shown in Figure 28, and its performance is presented in Figure 29 through Figure 32. The measured efficiencies shown in Figure 29 are typical for a buck converter producing a low output voltage (1V).

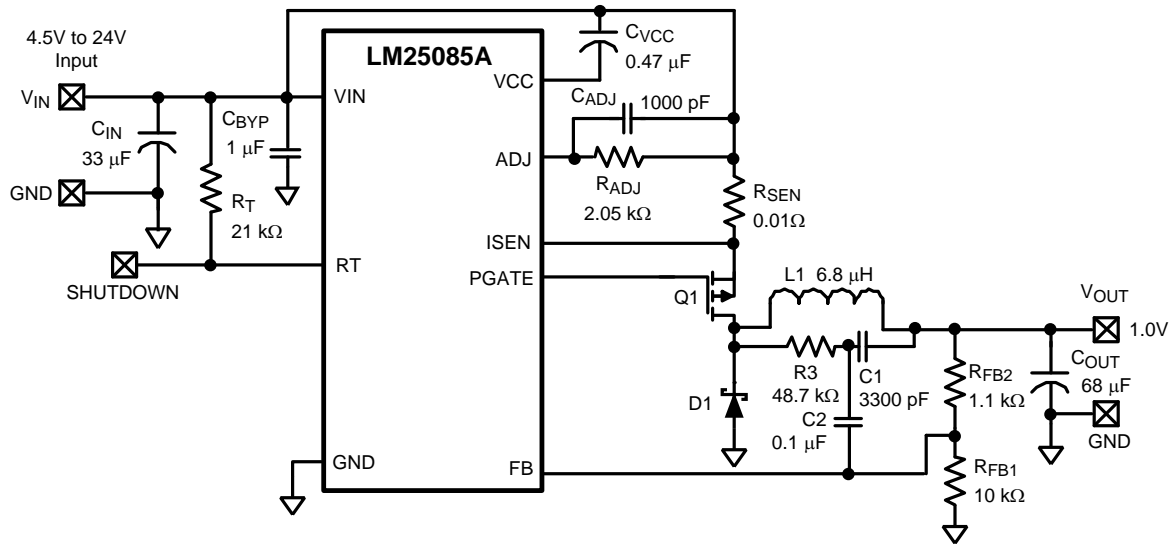

Figure 28. Example Circuit

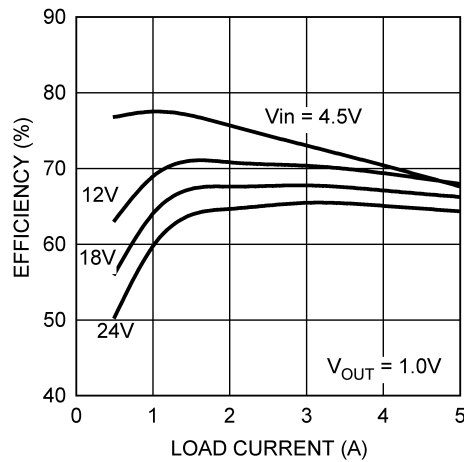

Figure 29. Efficiency vs. Load Current and V_{IN} (Circuit of Figure 28)

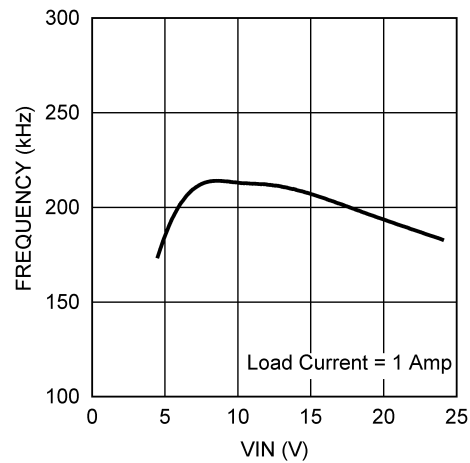

Figure 30. Frequency vs. V_{IN} (Circuit of Figure 28)

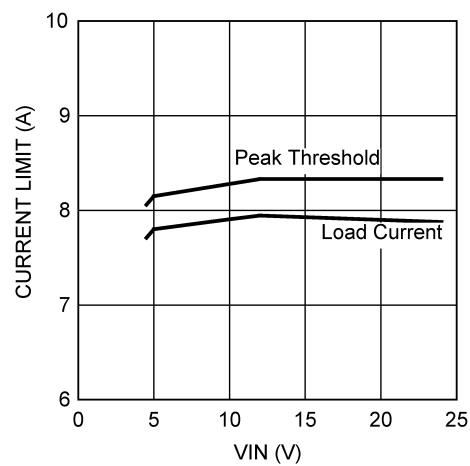

Figure 31. Current Limit vs. V_{IN} (Circuit of Figure 28)

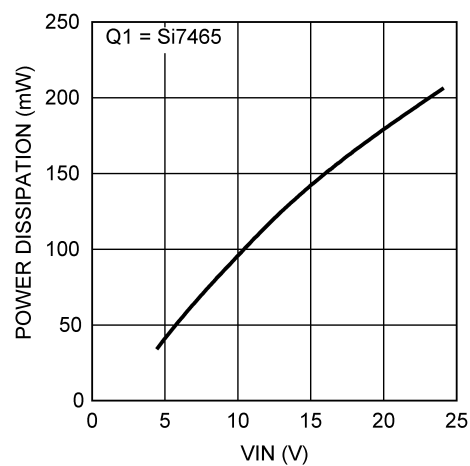

Figure 32. LM25085A Power Dissipation (Circuit of Figure 28)

Alternate Output Ripple Configurations

The minimum ripple configuration, using C1, C2 and R3, used in the example circuit [Figure 28](#), results in a low ripple amplitude at V_{OUT} determined mainly by the characteristics of the output capacitor and the ripple current in L1. This configuration allows multiple ceramic capacitors to be used for V_{OUT} if the output voltage is provided to several places on the PC board. However, if a slightly higher level of ripple at V_{OUT} is acceptable in the application, and distributed capacitance is not used, the ripple required for the FB comparator pin can be generated with fewer external components using the circuits shown below.

Reduced ripple configuration: In [Figure 33](#), R3, C1 and C2 are removed (compared to [Figure 28](#)). A low value resistor (R4) is added in series with C_{OUT} , and a capacitor (Cff) is added across R_{FB2} . Ripple is generated at V_{OUT} by the inductor's ripple current flowing through R4, and that ripple voltage is passed to the FB pin via Cff. The ripple at V_{OUT} can be set as low as 25 mVp-p since it is not attenuated by R_{FB2} and R_{FB1} . The minimum value for R4 is calculated from:

$$R4 = \frac{25 \text{ mV}}{I_{OR(\min)}}$$

where $I_{OR(\min)}$ is the minimum ripple current, which occurs at minimum input voltage. The minimum value for Cff is determined from:

$$C_{ff} = \frac{3 \times t_{ON(\max)}}{(R_{FB1} // R_{FB2})}$$

where $t_{ON(\max)}$ is the maximum on-time, which occurs at minimum V_{IN} . The next larger standard value capacitor should be used for Cff.

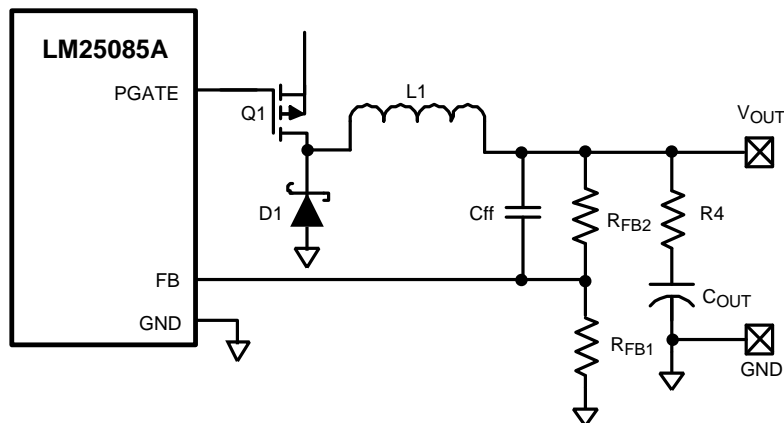

Figure 33. Reduced Ripple Configuration

b) Lowest cost configuration: This configuration, shown in [Figure 34](#), is the same as [Figure 33](#) except Cff is removed. Since the ripple voltage at V_{OUT} is attenuated by R_{FB2} and R_{FB1} , the minimum ripple required at V_{OUT} is equal to:

$$V_{RIP(\min)} = 25 \text{ mV} \times (R_{FB2} + R_{FB1}) / R_{FB1}$$

The minimum value for R4 is calculated from:

$$R4 = \frac{V_{RIP(\min)}}{I_{OR(\min)}}$$

where $I_{OR(\min)}$ is the minimum ripple current, which occurs at minimum input voltage.

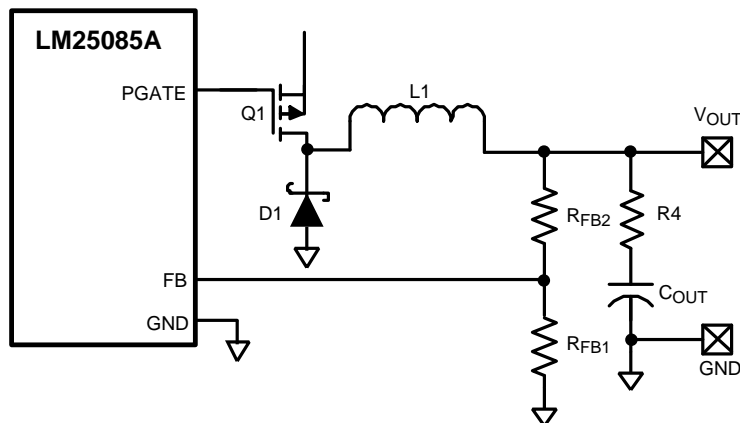

Figure 34. Lowest Cost Ripple Generating Configuration

PC Board Layout

In most applications, the heat sink pad or tab of Q1 is connected to the switch node, i.e. the junction of Q1, L1 and D1. While it is common to extend the PC board pad from under these devices to aid in heat dissipation, the pad size should be limited to minimize EMI radiation from this switching node. If the PC board layout allows, a similarly sized copper pad can be placed on the underside of the PC board, and connected with as many vias as possible to aid in heat dissipation.

The voltage regulation, over-voltage, and current limit comparators are very fast and can respond to short duration noise pulses. Layout considerations are therefore critical for optimum performance. The layout must be as neat and compact as possible with all the components as close as possible to their associated pins. Two major current loops conduct currents which switch very fast, requiring the loops to be as small as possible to minimize conducted and radiated EMI. The first loop is that formed by C_{IN} , Q1, L1, C_{OUT} , and back to C_{IN} . The second loop is that formed by D1, L1, C_{OUT} , and back to D1. The connection from the anode of D1 to the ground end of C_{IN} must be short and direct. C_{IN} must be as close as possible to the VIN and GND pins, and C_{VCC} must be as close as possible to the VIN and VCC pins.

If the anticipated internal power dissipation of the LM25085A will produce excessive junction temperatures during normal operation, a package option with an exposed pad must be used (HVSSOP-PowerPAD-8 or WSON-8). Effective use of the PC board ground plane can help dissipate heat. Additionally, the use of wide PC board traces, where possible, helps conduct heat away from the IC. Judicious positioning of the PC board within the end product, along with the use of any available air flow (forced or natural convection) also helps reduce the junction temperature.

REVISION HISTORY

Changes from Revision A (March 2013) to Revision B	Page
• Changed layout of National Data Sheet to TI format	21

PACKAGING INFORMATION

Orderable Device	Status (1)	Package Type	Package Drawing	Pins	Package Qty	Eco Plan (2)	Lead/Ball Finish	MSL Peak Temp (3)	Op Temp (°C)	Top-Side Markings (4)	Samples
LM25085AMM/NOPB	ACTIVE	VSSOP	DGK	8	1000	Green (RoHS & no Sb/Br)	CU SN	Level-1-260C-UNLIM	-40 to 125	SVZA	Samples
LM25085AMME/NOPB	ACTIVE	VSSOP	DGK	8	250	Green (RoHS & no Sb/Br)	CU SN	Level-1-260C-UNLIM	-40 to 125	SVZA	Samples
LM25085AMMX/NOPB	ACTIVE	VSSOP	DGK	8	3500	Green (RoHS & no Sb/Br)	CU SN	Level-1-260C-UNLIM	-40 to 125	SVZA	Samples
LM25085AMY/NOPB	ACTIVE	MSOP- PowerPAD	DGN	8	1000	Green (RoHS & no Sb/Br)	CU SN	Level-1-260C-UNLIM	-40 to 125	SVYA	Samples
LM25085AMYE/NOPB	ACTIVE	MSOP- PowerPAD	DGN	8	250	Green (RoHS & no Sb/Br)	CU SN	Level-1-260C-UNLIM	-40 to 125	SVYA	Samples
LM25085AMYX/NOPB	ACTIVE	MSOP- PowerPAD	DGN	8	3500	Green (RoHS & no Sb/Br)	CU SN	Level-1-260C-UNLIM	-40 to 125	SVYA	Samples
LM25085ASD/NOPB	ACTIVE	WSON	NGQ	8	1000	Green (RoHS & no Sb/Br)	CU SN	Level-1-260C-UNLIM	-40 to 125	L246A	Samples
LM25085ASDE/NOPB	ACTIVE	WSON	NGQ	8	250	Green (RoHS & no Sb/Br)	CU SN	Level-1-260C-UNLIM	-40 to 125	L246A	Samples
LM25085ASDX/NOPB	ACTIVE	WSON	NGQ	8	4500	Green (RoHS & no Sb/Br)	CU SN	Level-1-260C-UNLIM	-40 to 125	L246A	Samples

(1) The marketing status values are defined as follows:

ACTIVE: Product device recommended for new designs.

LIFEBUY: TI has announced that the device will be discontinued, and a lifetime-buy period is in effect.

NRND: Not recommended for new designs. Device is in production to support existing customers, but TI does not recommend using this part in a new design.

PREVIEW: Device has been announced but is not in production. Samples may or may not be available.

OBSOLETE: TI has discontinued the production of the device.

(2) Eco Plan - The planned eco-friendly classification: Pb-Free (RoHS), Pb-Free (RoHS Exempt), or Green (RoHS & no Sb/Br) - please check <http://www.ti.com/productcontent> for the latest availability information and additional product content details.

TBD: The Pb-Free/Green conversion plan has not been defined.

Pb-Free (RoHS): TI's terms "Lead-Free" or "Pb-Free" mean semiconductor products that are compatible with the current RoHS requirements for all 6 substances, including the requirement that lead not exceed 0.1% by weight in homogeneous materials. Where designed to be soldered at high temperatures, TI Pb-Free products are suitable for use in specified lead-free processes.

Pb-Free (RoHS Exempt): This component has a RoHS exemption for either 1) lead-based flip-chip solder bumps used between the die and package, or 2) lead-based die adhesive used between the die and leadframe. The component is otherwise considered Pb-Free (RoHS compatible) as defined above.

Green (RoHS & no Sb/Br): TI defines "Green" to mean Pb-Free (RoHS compatible), and free of Bromine (Br) and Antimony (Sb) based flame retardants (Br or Sb do not exceed 0.1% by weight in homogeneous material)

⁽³⁾ MSL, Peak Temp. -- The Moisture Sensitivity Level rating according to the JEDEC industry standard classifications, and peak solder temperature.

⁽⁴⁾ Only one of markings shown within the brackets will appear on the physical device.

Important Information and Disclaimer: The information provided on this page represents TI's knowledge and belief as of the date that it is provided. TI bases its knowledge and belief on information provided by third parties, and makes no representation or warranty as to the accuracy of such information. Efforts are underway to better integrate information from third parties. TI has taken and continues to take reasonable steps to provide representative and accurate information but may not have conducted destructive testing or chemical analysis on incoming materials and chemicals. TI and TI suppliers consider certain information to be proprietary, and thus CAS numbers and other limited information may not be available for release.

In no event shall TI's liability arising out of such information exceed the total purchase price of the TI part(s) at issue in this document sold by TI to Customer on an annual basis.

DGN0008A

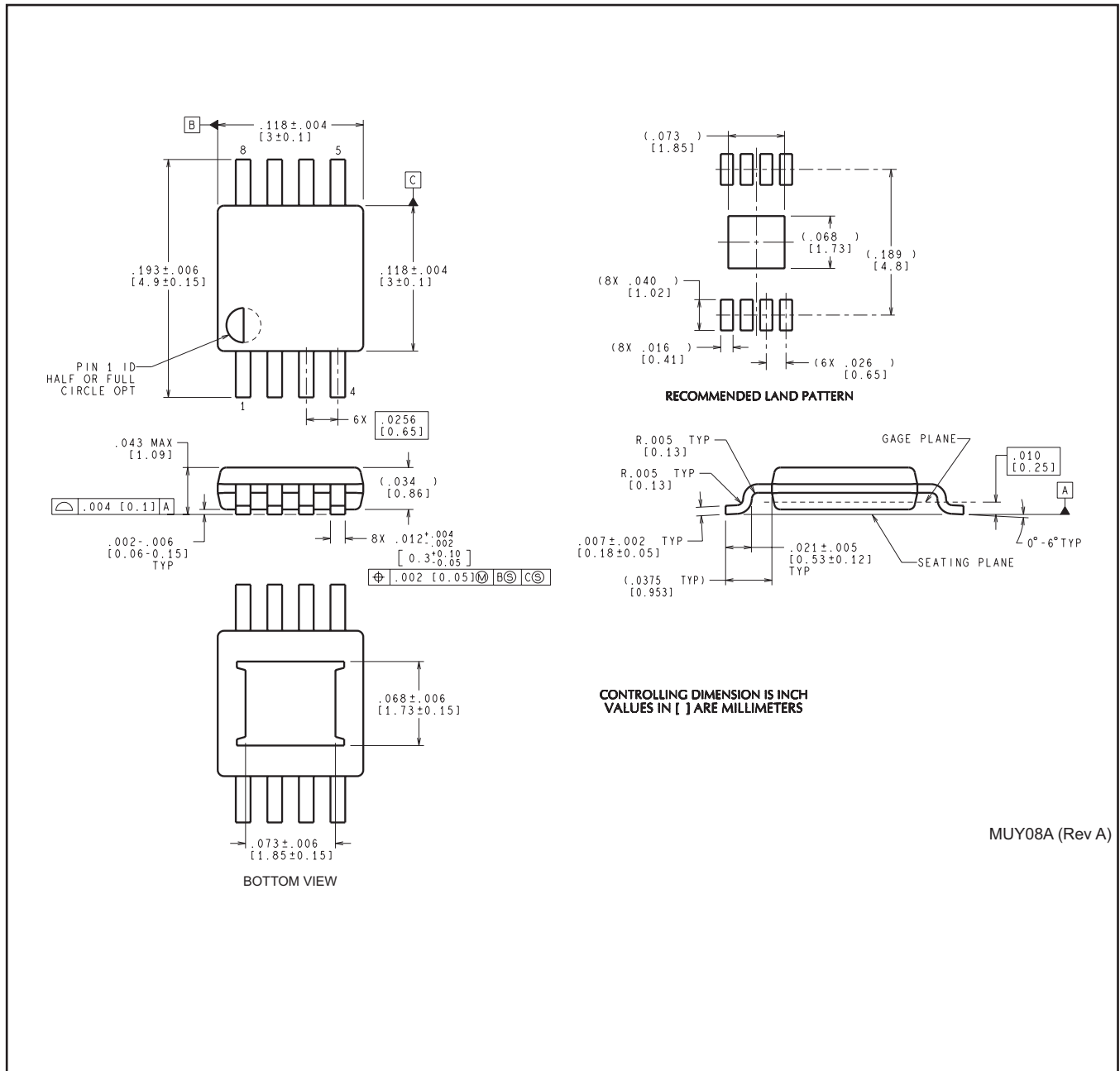

MUY08A (Rev A)

NGQ0008A

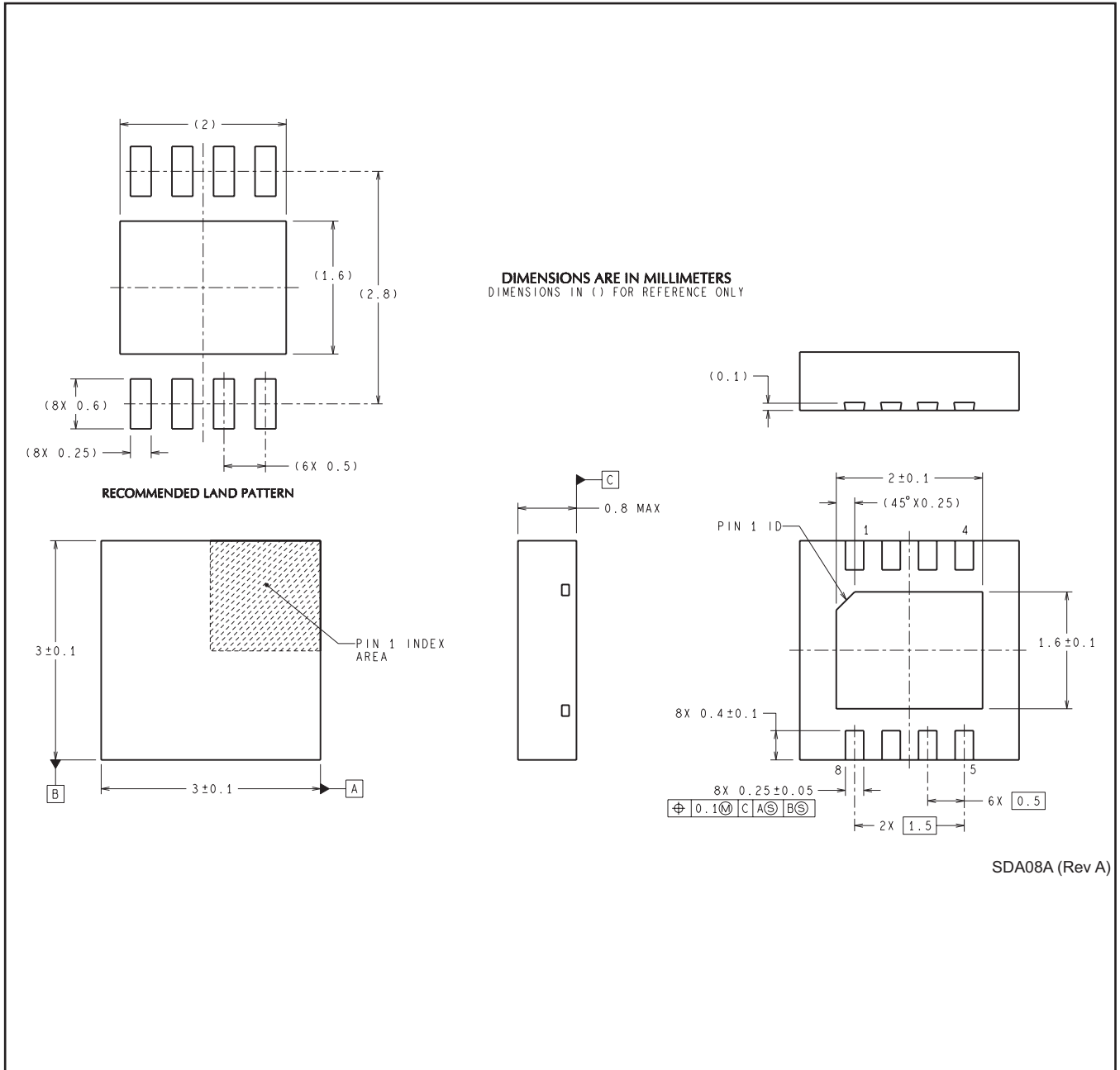

IMPORTANT NOTICE

Texas Instruments Incorporated and its subsidiaries (TI) reserve the right to make corrections, enhancements, improvements and other changes to its semiconductor products and services per JESD46, latest issue, and to discontinue any product or service per JESD48, latest issue. Buyers should obtain the latest relevant information before placing orders and should verify that such information is current and complete. All semiconductor products (also referred to herein as "components") are sold subject to TI's terms and conditions of sale supplied at the time of order acknowledgment.

TI warrants performance of its components to the specifications applicable at the time of sale, in accordance with the warranty in TI's terms and conditions of sale of semiconductor products. Testing and other quality control techniques are used to the extent TI deems necessary to support this warranty. Except where mandated by applicable law, testing of all parameters of each component is not necessarily performed.

TI assumes no liability for applications assistance or the design of Buyers' products. Buyers are responsible for their products and applications using TI components. To minimize the risks associated with Buyers' products and applications, Buyers should provide adequate design and operating safeguards.

TI does not warrant or represent that any license, either express or implied, is granted under any patent right, copyright, mask work right, or other intellectual property right relating to any combination, machine, or process in which TI components or services are used. Information published by TI regarding third-party products or services does not constitute a license to use such products or services or a warranty or endorsement thereof. Use of such information may require a license from a third party under the patents or other intellectual property of the third party, or a license from TI under the patents or other intellectual property of TI.

Reproduction of significant portions of TI information in TI data books or data sheets is permissible only if reproduction is without alteration and is accompanied by all associated warranties, conditions, limitations, and notices. TI is not responsible or liable for such altered documentation. Information of third parties may be subject to additional restrictions.

Resale of TI components or services with statements different from or beyond the parameters stated by TI for that component or service voids all express and any implied warranties for the associated TI component or service and is an unfair and deceptive business practice. TI is not responsible or liable for any such statements.

Buyer acknowledges and agrees that it is solely responsible for compliance with all legal, regulatory and safety-related requirements concerning its products, and any use of TI components in its applications, notwithstanding any applications-related information or support that may be provided by TI. Buyer represents and agrees that it has all the necessary expertise to create and implement safeguards which anticipate dangerous consequences of failures, monitor failures and their consequences, lessen the likelihood of failures that might cause harm and take appropriate remedial actions. Buyer will fully indemnify TI and its representatives against any damages arising out of the use of any TI components in safety-critical applications.

In some cases, TI components may be promoted specifically to facilitate safety-related applications. With such components, TI's goal is to help enable customers to design and create their own end-product solutions that meet applicable functional safety standards and requirements. Nonetheless, such components are subject to these terms.

No TI components are authorized for use in FDA Class III (or similar life-critical medical equipment) unless authorized officers of the parties have executed a special agreement specifically governing such use.

Only those TI components which TI has specifically designated as military grade or "enhanced plastic" are designed and intended for use in military/aerospace applications or environments. Buyer acknowledges and agrees that any military or aerospace use of TI components which have **not** been so designated is solely at the Buyer's risk, and that Buyer is solely responsible for compliance with all legal and regulatory requirements in connection with such use.

TI has specifically designated certain components as meeting ISO/TS16949 requirements, mainly for automotive use. In any case of use of non-designated products, TI will not be responsible for any failure to meet ISO/TS16949.

Products

Audio	www.ti.com/audio
Amplifiers	amplifier.ti.com
Data Converters	dataconverter.ti.com
DLP® Products	www.dlp.com
DSP	dsp.ti.com
Clocks and Timers	www.ti.com/clocks
Interface	interface.ti.com
Logic	logic.ti.com
Power Mgmt	power.ti.com
Microcontrollers	microcontroller.ti.com
RFID	www.ti-rfid.com
OMAP Applications Processors	www.ti.com/omap
Wireless Connectivity	www.ti.com/wirelessconnectivity

Applications

Automotive and Transportation	www.ti.com/automotive
Communications and Telecom	www.ti.com/communications
Computers and Peripherals	www.ti.com/computers
Consumer Electronics	www.ti.com/consumer-apps
Energy and Lighting	www.ti.com/energy
Industrial	www.ti.com/industrial
Medical	www.ti.com/medical
Security	www.ti.com/security
Space, Avionics and Defense	www.ti.com/space-avionics-defense
Video and Imaging	www.ti.com/video

TI E2E Community

e2e.ti.com