

LM1558QML Dual Operational Amplifier

 Check for Samples: [LM1558QML](#)

FEATURES

- No Frequency Compensation Required
- Short-Circuit Protection
- Wide Common-Mode and Differential Voltage Ranges
- Low-Power Consumption
- 8-Lead Can and 8-Lead mini DIP
- No Latch up when Input Common Mode Range is Exceeded

DESCRIPTION

The LM1558 is a general purpose dual operational amplifier. The two amplifiers share a common bias network and power supply leads. Otherwise, their operation is completely independent.

Connection Diagram

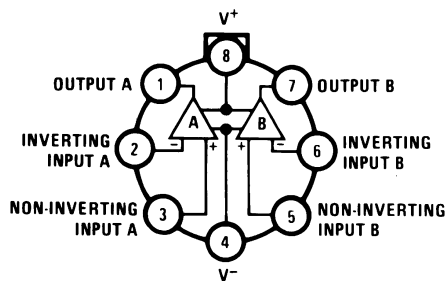

**Figure 1. TO-99 Package
Top View
See Package Number LMC**

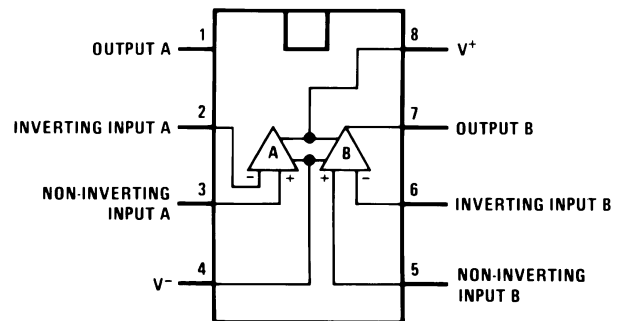

**Figure 2. CDIP Package
Top View
See Package Number NAB0008A**



Please be aware that an important notice concerning availability, standard warranty, and use in critical applications of Texas Instruments semiconductor products and disclaimers thereto appears at the end of this data sheet.

All trademarks are the property of their respective owners.

Schematic Diagram

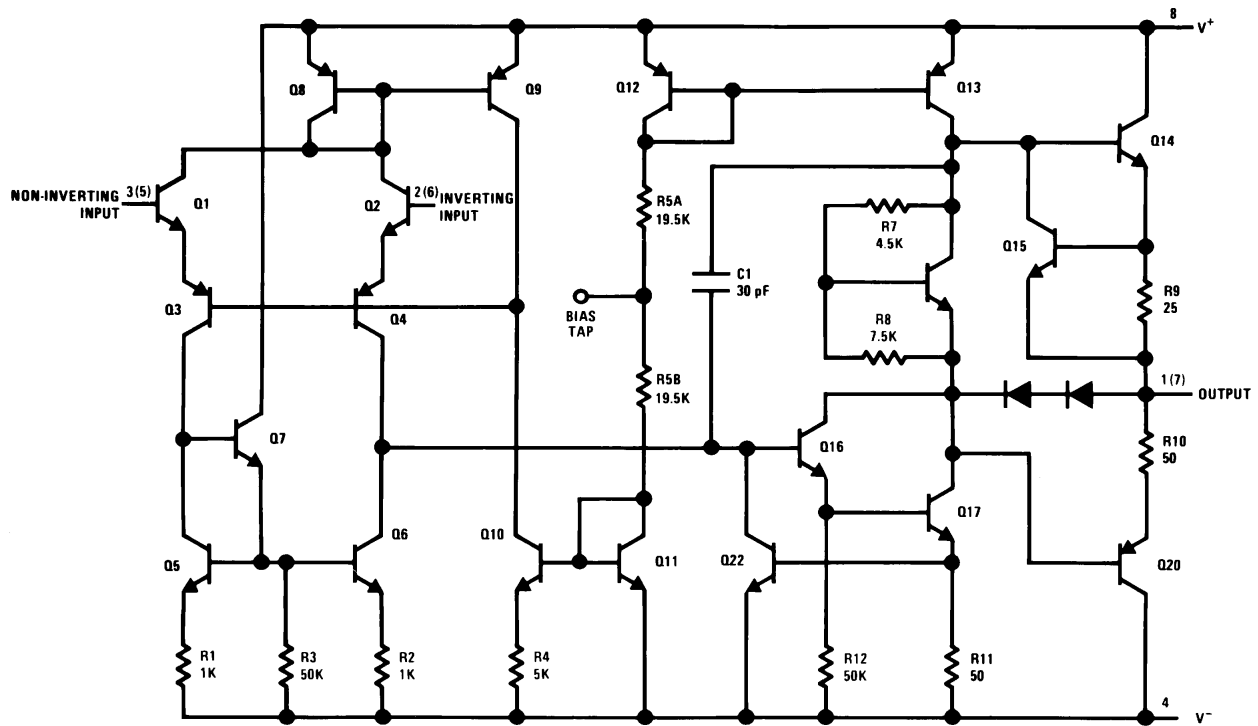

Numbers in parentheses are pin numbers for amplifier B.



These devices have limited built-in ESD protection. The leads should be shorted together or the device placed in conductive foam during storage or handling to prevent electrostatic damage to the MOS gates.

Absolute Maximum Ratings⁽¹⁾

Supply Voltage				±22V
Power Dissipation ⁽²⁾		8LD TO-99	500 mW	
		8LD CERDIP	TBD	
Differential Input Voltage				±30V
Input Voltage ⁽³⁾				±15V
Output Short-Circuit Duration				Continuous
Operating Temperature Range				-55°C ≤ T _A ≤ +125°C
Maximum Junction Temperature				150°C
Storage Temperature Range				-65°C ≤ T _A ≤ +150°C
Lead Temperature (Soldering, 10 sec.)				260°C
Thermal Resistance	θ _{JA}	TO-99 8LD	Still Air	150°C/W
			500LF/Min Air flow	85°C/W
		CERDIP 8LD	Still Air	125°C/W
			500LF/Min Air flow	70°C/W
	θ _{JC}	TO-99 8LD	30°C/W	
		CERDIP 8LD	22°C/W	
ESD tolerance ⁽⁴⁾				300V

- (1) "Absolute Maximum Ratings" indicate limits beyond which damage to the device may occur. Operating Ratings indicate conditions for which the device is intended to be functional, but do not ensure specific performance limits. For ensured specifications and test conditions, see the Electrical Characteristics. The ensured specifications apply only for the test conditions listed.
- (2) The maximum power dissipation must be derated at elevated temperatures and is dictated by T_{Jmax} (maximum junction temperature), θ_{JA} (package junction to ambient thermal resistance), and T_A (ambient temperature). The maximum allowable power dissipation at any temperature is P_{Dmax} = (T_{Jmax} - T_A)/θ_{JA} or the number given in the Absolute Maximum Ratings, whichever is lower.
- (3) For supply Voltages less than ±15V, the absolute maximum input Voltage is equal to the supply Voltage.
- (4) Human body model, 1.5 kΩ in series with 100 pF.

Quality Conformance Inspection

MIL-STD-883, Method 5005 - Group A

Subgroup	Description	Temp (C)
1	Static tests at	+25
2	Static tests at	+125
3	Static tests at	-55
4	Dynamic tests at	+25
5	Dynamic tests at	+125
6	Dynamic tests at	-55
7	Functional tests at	+25
8A	Functional tests at	+125
8B	Functional tests at	-55
9	Switching tests at	+25
10	Switching tests at	+125
11	Switching tests at	-55

LM1558 Electrical Characteristics DC Parameters

The following conditions apply, unless otherwise specified. $V_{CC} = \pm 15V$, $V_{CM} = 0V$, $R_S = 10K\Omega$

Symbol	Parameter	Conditions	Note	Min	Max	Unit	Sub-group		
V_{IO}	Input Offset Voltage	$V_{CM} = -12V$		-5.0	5.0	mV	1		
				-6.0	6.0	mV	2, 3		
		$V_{CM} = +12V$		-5.0	5.0	mV	1		
				-6.0	6.0	mV	2, 3		
		$V_{CM} = 0V$		-5.0	5.0	mV	1		
				-6.0	6.0	mV	2, 3		
		$V_{CC} = 0V, R_S = 50\Omega$		-5.0	5.0	mV	1		
				-6.0	6.0	mV	2, 3		
		$V_{CC} = \pm 5V, V_{CM} = 0V$		-5.0	5.0	mV	1		
				-6.0	6.0	mV	2, 3		
		I_{IO}	Input Offset Current	$V_{CM} = -12V$		-200	200	nA	1
						-500	500	nA	2, 3
$V_{CM} = +12V$				-200	200	nA	1		
				-500	500	nA	2, 3		
$V_{CM} = 0V$				-200	200	nA	1		
				-500	500	nA	2, 3		
$V_{CC} = \pm 5V, V_{CM} = 0V$				-200	200	nA	1		
				-500	500	nA	2, 3		
I_{IB}	Input Bias Current			$V_{CM} = -12V$			500	nA	1
							1500	nA	2, 3
				$V_{CM} = +12V$			500	nA	1
							1500	nA	2, 3
		$V_{CM} = 0V$			500	nA	1		
					1500	nA	2, 3		
		$V_{CC} = \pm 5V, V_{CM} = 0V$			500	nA	1		
					1500	nA	2, 3		
		PSRR	Power Supply Rejection Ratio	$\pm 5V \leq V_{CC} \leq \pm 15V$		77		dB	1, 2, 3
		CMRR	Common Mode Rejection Ratio	$-12V \leq V_{CM} \leq 12V$		70		dB	1, 2, 3
		I_{CC}	Power Supply Current	$R_S = 50\Omega$ (both amplifiers measured together)			5.0	mA	1, 2,
							7.0	mA	3
+ I_{OS}	Short Circuit Current	$R_S = 50\Omega, V_O = 0V$		-45	-14	mA	1		
				-45	-9	mA	2		
				-50	-9	mA	3		
- I_{OS}	Short Circuit Current	$R_S = 50\Omega, V_O = 0V$		14	45	mA	1		
				9.0	45	mA	2		
				9.0	50	mA	3		
V_I	Input Voltage Range		See ⁽¹⁾	-12	12	V	1, 2, 3		
R_I	Input Resistance	$R_I = 5(KT/q I_{IB})$	See ⁽²⁾	0.3		M Ω	1		
+ V_{OP}	Output Voltage Swing	$R_S = 50\Omega, R_L = 10K\Omega, V_{CC} = \pm 20V$		16		V	4, 5, 6		
		$R_S = 50\Omega, R_L = 2K\Omega, V_{CC} = \pm 20V$		15		V	4, 5, 6		
		$R_S = 50\Omega, R_L = 10K\Omega$		12		V	4, 5, 6		
		$R_S = 50\Omega, R_L = 2K\Omega$		10		V	4, 5, 6		

(1) Specified by the CMRR test.

(2) Specified parameter not tested.

LM1558 Electrical Characteristics DC Parameters (continued)

The following conditions apply, unless otherwise specified. $V_{CC} = \pm 15V$, $V_{CM} = 0V$, $R_S = 10K\Omega$

Symbol	Parameter	Conditions	Note	Min	Max	Unit	Sub-group
- V_{OP}	Output Voltage Swing	$R_S = 50\Omega$, $R_L = 10K\Omega$, $V_{CC} = \pm 20V$			-16	V	4, 5, 6
		$R_S = 50\Omega$, $R_L = 2K\Omega$, $V_{CC} = \pm 20V$			-15	V	4, 5, 6
		$R_S = 50\Omega$, $R_L = 10K\Omega$			-12	V	4, 5, 6
		$R_S = 50\Omega$, $R_L = 2K\Omega$			-10	V	4, 5, 6
+ A_{VS}	Large Signal Voltage Gain	$R_S = 50\Omega$, $R_L = 2K\Omega$, $V_O = 10V$		50		V/mV	4
				25		V/mV	5, 6
- A_{VS}	Large Signal Voltage Gain	$R_S = 50\Omega$, $R_L = 2K\Omega$, $V_O = -10V$		50		V/mV	4
				25		V/mV	5, 6

LM1558 Electrical Characteristics AC Parameters

The following conditions apply, unless otherwise specified. $V_{CC} = \pm 15V$, $V_{CM} = 0V$



Symbol	Parameter	Conditions	Note	Min	Max	Unit	Sub-group
+SR	Slew Rate	$V_I = -5$ to $5V$		0.2		V/ μ S	9
		$V_I = -5$ to $5V$, $R_L = 2K\Omega$, $C_L = 100pF$	See ⁽¹⁾	0.2		V/ μ S	9
-SR	Slew Rate	$V_I = 5$ to $-5V$		0.2		V/ μ S	9
		$V_I = 5$ to $-5V$, $R_L = 2K\Omega$, $C_L = 100pF$	See ⁽¹⁾	0.2		V/ μ S	9
GBW	Gain Bandwidth	$V_I = 50mV_{RMS}$, $f = 20KHz$, $R_S = 50\Omega$, $R_L = 2K\Omega$		250		KHz	9
t_R	Rise Time	$R_L = 2K\Omega$, $C_L = 100pF$	See ⁽¹⁾		1	μ S	9
OS	Overshoot	$R_L = 2K\Omega$, $C_L = 100pF$	See ⁽¹⁾		30	%	9

(1) Specified parameter not tested.

REVISION HISTORY SECTION

Date Released	Revision	Section	Originator	Changes
05/24/05	A	New Released Corporate format. Electrical Section	R. Malone	1 MDS data sheet converted into one corp. data sheet format. MDS data MNLM1558–X, Rev. 0B0 will be archived. Deleted Drift table from electrical section. Reason: Referenced products are 883 only.
08/04/05	B	Added Thermal Resistance limit in the Absolute Maximum Ratings Section	R. Malone	Added Thermal Resistance limit in the Absolute Maximum Ratings Section for all packages.
03/20/13	B	All		Changed layout of National Data Sheet to TI format

PACKAGING INFORMATION

Orderable Device	Status (1)	Package Type	Package Drawing	Pins	Package Qty	Eco Plan (2)	Lead/Ball Finish	MSL Peak Temp (3)	Op Temp (°C)	Top-Side Markings (4)	Samples
LM1558H/883	ACTIVE	TO-99	LMC	8	20	TBD	Call TI	Call TI	-55 to 125	LM1558H/883 Q ACO LM1558H/883 Q >T	
LM1558J/883	ACTIVE	CDIP	NAB	8	40	TBD	Call TI	Call TI	-55 to 125	LM1558J /883 Q ACO /883 Q >T	

(1) The marketing status values are defined as follows:

ACTIVE: Product device recommended for new designs.

LIFEBUY: TI has announced that the device will be discontinued, and a lifetime-buy period is in effect.

NRND: Not recommended for new designs. Device is in production to support existing customers, but TI does not recommend using this part in a new design.

PREVIEW: Device has been announced but is not in production. Samples may or may not be available.

OBSOLETE: TI has discontinued the production of the device.

(2) Eco Plan - The planned eco-friendly classification: Pb-Free (RoHS), Pb-Free (RoHS Exempt), or Green (RoHS & no Sb/Br) - please check <http://www.ti.com/productcontent> for the latest availability information and additional product content details.

TBD: The Pb-Free/Green conversion plan has not been defined.

Pb-Free (RoHS): TI's terms "Lead-Free" or "Pb-Free" mean semiconductor products that are compatible with the current RoHS requirements for all 6 substances, including the requirement that lead not exceed 0.1% by weight in homogeneous materials. Where designed to be soldered at high temperatures, TI Pb-Free products are suitable for use in specified lead-free processes.

Pb-Free (RoHS Exempt): This component has a RoHS exemption for either 1) lead-based flip-chip solder bumps used between the die and package, or 2) lead-based die adhesive used between the die and leadframe. The component is otherwise considered Pb-Free (RoHS compatible) as defined above.

Green (RoHS & no Sb/Br): TI defines "Green" to mean Pb-Free (RoHS compatible), and free of Bromine (Br) and Antimony (Sb) based flame retardants (Br or Sb do not exceed 0.1% by weight in homogeneous material)

(3) MSL, Peak Temp. -- The Moisture Sensitivity Level rating according to the JEDEC industry standard classifications, and peak solder temperature.

(4) Only one of markings shown within the brackets will appear on the physical device.

Important Information and Disclaimer: The information provided on this page represents TI's knowledge and belief as of the date that it is provided. TI bases its knowledge and belief on information provided by third parties, and makes no representation or warranty as to the accuracy of such information. Efforts are underway to better integrate information from third parties. TI has taken and continues to take reasonable steps to provide representative and accurate information but may not have conducted destructive testing or chemical analysis on incoming materials and chemicals. TI and TI suppliers consider certain information to be proprietary, and thus CAS numbers and other limited information may not be available for release.

In no event shall TI's liability arising out of such information exceed the total purchase price of the TI part(s) at issue in this document sold by TI to Customer on an annual basis.

NAB0008A

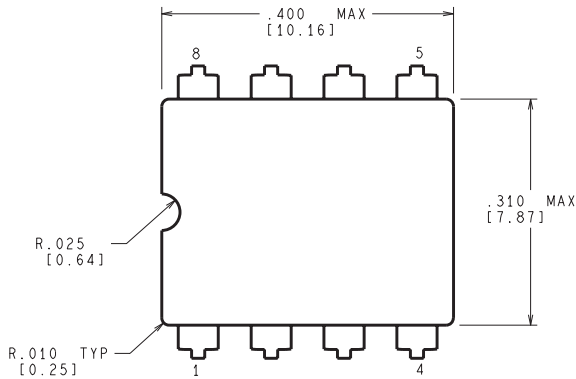

CONTROLLING DIMENSION IS INCH
VALUES IN [] ARE MILLIMETERS

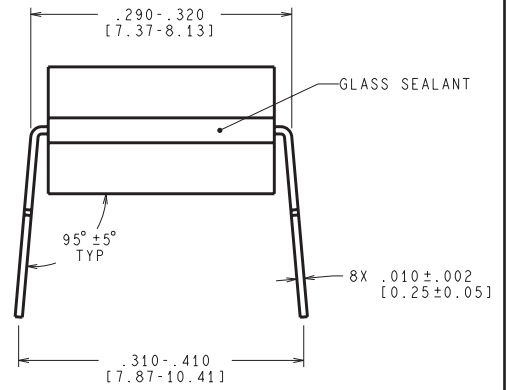
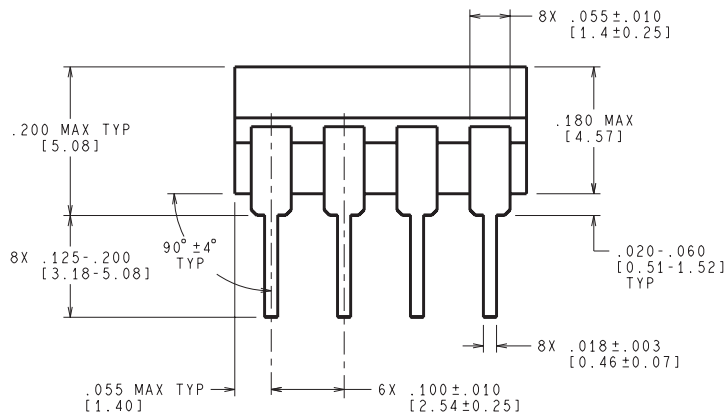

J08A (Rev M)

LMC (O-MBCY-W8)

METAL CYLINDRICAL PACKAGE

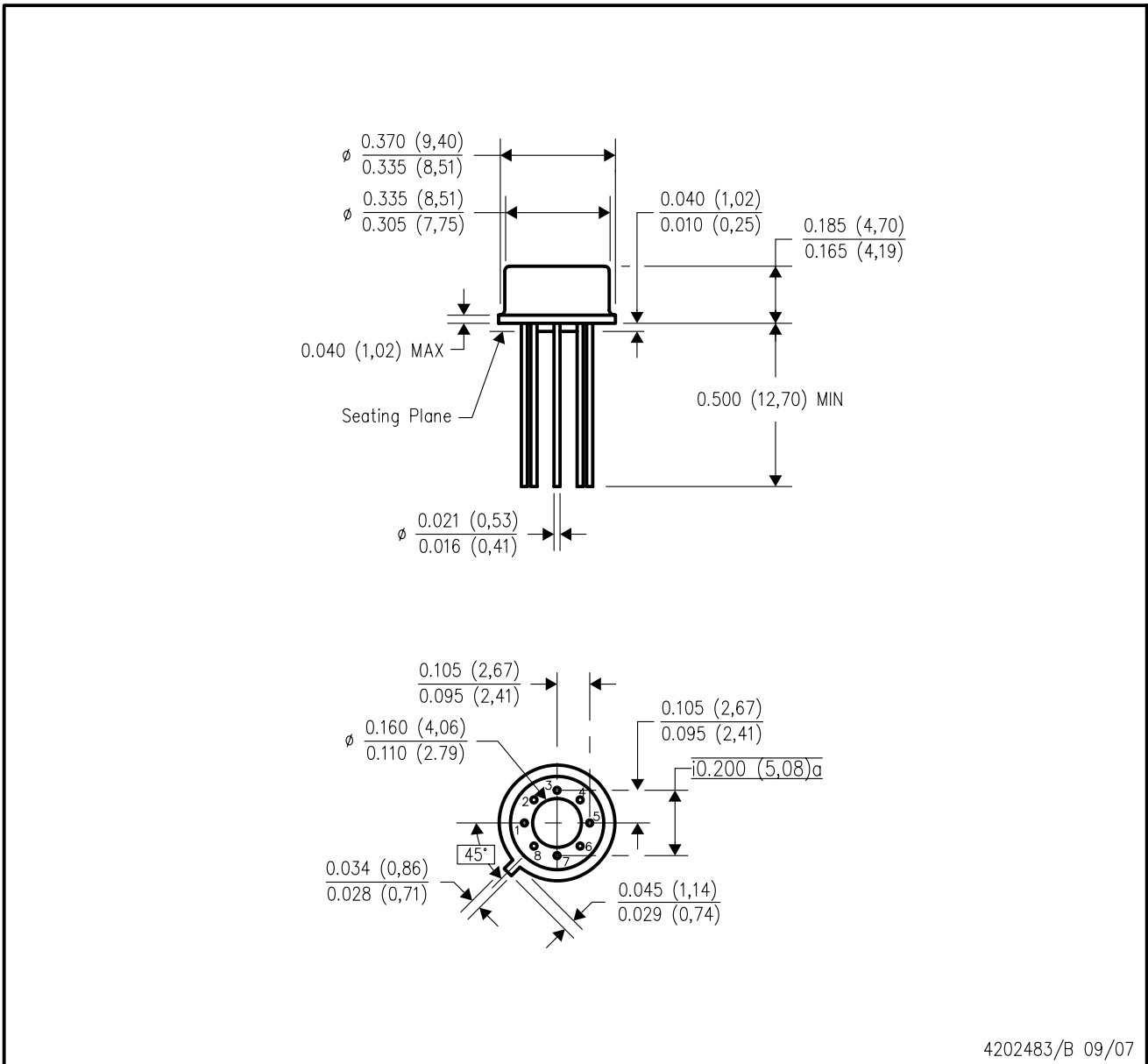

- NOTES:
- A. All linear dimensions are in inches (millimeters).
 - B. This drawing is subject to change without notice.
 - C. Leads in true position within 0.010 (0,25) R @ MMC at seating plane.
 - D. Pin numbers shown for reference only. Numbers may not be marked on package.
 - E. Falls within JEDEC MO-002/TO-99.

IMPORTANT NOTICE

Texas Instruments Incorporated and its subsidiaries (TI) reserve the right to make corrections, enhancements, improvements and other changes to its semiconductor products and services per JESD46, latest issue, and to discontinue any product or service per JESD48, latest issue. Buyers should obtain the latest relevant information before placing orders and should verify that such information is current and complete. All semiconductor products (also referred to herein as "components") are sold subject to TI's terms and conditions of sale supplied at the time of order acknowledgment.

TI warrants performance of its components to the specifications applicable at the time of sale, in accordance with the warranty in TI's terms and conditions of sale of semiconductor products. Testing and other quality control techniques are used to the extent TI deems necessary to support this warranty. Except where mandated by applicable law, testing of all parameters of each component is not necessarily performed.

TI assumes no liability for applications assistance or the design of Buyers' products. Buyers are responsible for their products and applications using TI components. To minimize the risks associated with Buyers' products and applications, Buyers should provide adequate design and operating safeguards.

TI does not warrant or represent that any license, either express or implied, is granted under any patent right, copyright, mask work right, or other intellectual property right relating to any combination, machine, or process in which TI components or services are used. Information published by TI regarding third-party products or services does not constitute a license to use such products or services or a warranty or endorsement thereof. Use of such information may require a license from a third party under the patents or other intellectual property of the third party, or a license from TI under the patents or other intellectual property of TI.

Reproduction of significant portions of TI information in TI data books or data sheets is permissible only if reproduction is without alteration and is accompanied by all associated warranties, conditions, limitations, and notices. TI is not responsible or liable for such altered documentation. Information of third parties may be subject to additional restrictions.

Resale of TI components or services with statements different from or beyond the parameters stated by TI for that component or service voids all express and any implied warranties for the associated TI component or service and is an unfair and deceptive business practice. TI is not responsible or liable for any such statements.

Buyer acknowledges and agrees that it is solely responsible for compliance with all legal, regulatory and safety-related requirements concerning its products, and any use of TI components in its applications, notwithstanding any applications-related information or support that may be provided by TI. Buyer represents and agrees that it has all the necessary expertise to create and implement safeguards which anticipate dangerous consequences of failures, monitor failures and their consequences, lessen the likelihood of failures that might cause harm and take appropriate remedial actions. Buyer will fully indemnify TI and its representatives against any damages arising out of the use of any TI components in safety-critical applications.

In some cases, TI components may be promoted specifically to facilitate safety-related applications. With such components, TI's goal is to help enable customers to design and create their own end-product solutions that meet applicable functional safety standards and requirements. Nonetheless, such components are subject to these terms.

No TI components are authorized for use in FDA Class III (or similar life-critical medical equipment) unless authorized officers of the parties have executed a special agreement specifically governing such use.

Only those TI components which TI has specifically designated as military grade or "enhanced plastic" are designed and intended for use in military/aerospace applications or environments. Buyer acknowledges and agrees that any military or aerospace use of TI components which have **not** been so designated is solely at the Buyer's risk, and that Buyer is solely responsible for compliance with all legal and regulatory requirements in connection with such use.

TI has specifically designated certain components as meeting ISO/TS16949 requirements, mainly for automotive use. In any case of use of non-designated products, TI will not be responsible for any failure to meet ISO/TS16949.

Products

Audio	www.ti.com/audio
Amplifiers	amplifier.ti.com
Data Converters	dataconverter.ti.com
DLP® Products	www.dlp.com
DSP	dsp.ti.com
Clocks and Timers	www.ti.com/clocks
Interface	interface.ti.com
Logic	logic.ti.com
Power Mgmt	power.ti.com
Microcontrollers	microcontroller.ti.com
RFID	www.ti-rfid.com
OMAP Applications Processors	www.ti.com/omap
Wireless Connectivity	www.ti.com/wirelessconnectivity

Applications

Automotive and Transportation	www.ti.com/automotive
Communications and Telecom	www.ti.com/communications
Computers and Peripherals	www.ti.com/computers
Consumer Electronics	www.ti.com/consumer-apps
Energy and Lighting	www.ti.com/energy
Industrial	www.ti.com/industrial
Medical	www.ti.com/medical
Security	www.ti.com/security
Space, Avionics and Defense	www.ti.com/space-avionics-defense
Video and Imaging	www.ti.com/video

TI E2E Community

e2e.ti.com