

LM111QML Voltage Comparator

 Check for Samples: [LM111QML](#)

FEATURES

- Available with radiation ensured
 - High Dose Rate 50 krad(Si)
 - Low Dose and ELDRS Free 100 krad(Si)
- Operates from single 5V supply
- Input current: 200 nA max. over temperature
- Offset current: 20 nA max. over temperature
- Differential input voltage range: $\pm 30V$
- Power consumption: 135 mW at $\pm 15V$
- Power supply voltage, single 5V to $\pm 15V$
- Offset voltage null capability
- Strobe capability

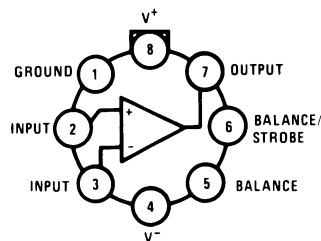
DESCRIPTION

The LM111 is a voltage comparator that has input currents nearly a thousand times lower than devices such as the LM106 or LM710. It is also designed to operate over a wider range of supply voltages: from standard $\pm 15V$ op amp supplies down to the single 5V supply used for IC logic. The output is compatible with RTL, DTL and TTL as well as MOS circuits. Further, it can drive lamps or relays, switching voltages up to 50V at currents as high as 50 mA.

Both the inputs and the output of the LM111 can be isolated from system ground, and the output can drive loads referred to ground, the positive supply or the negative supply. Offset balancing and strobe capability are provided and outputs can be wire OR'ed. Although slower than the LM106 and LM710 (200 ns response time vs 40 ns) the device is also much less prone to spurious oscillations. The LM111 has the same pin configuration as the LM106 and LM710.

Connection Diagrams

TO-99 Package



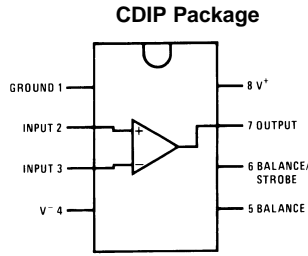
Note: Pin 4 connected to case

Figure 1. Top View
Package Number LMC0008C

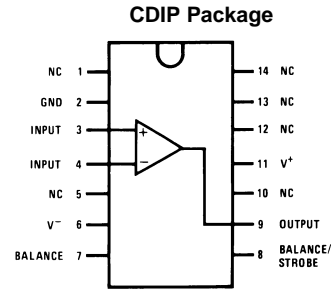


Please be aware that an important notice concerning availability, standard warranty, and use in critical applications of Texas Instruments semiconductor products and disclaimers thereto appears at the end of this data sheet.

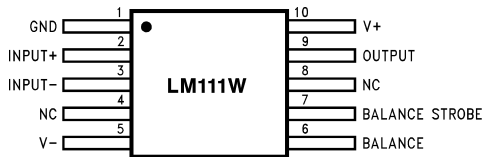
All trademarks are the property of their respective owners.



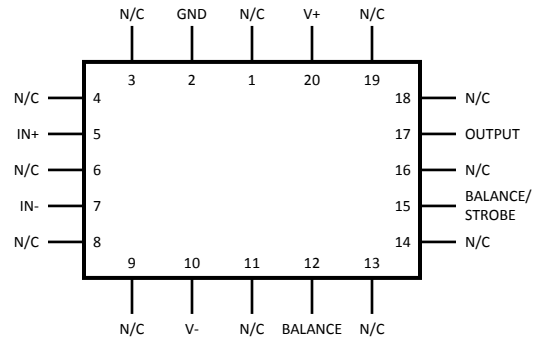
**Figure 2. Top View
Package Number NAB008A**



**Figure 3. Top View
Package Number J0014A**

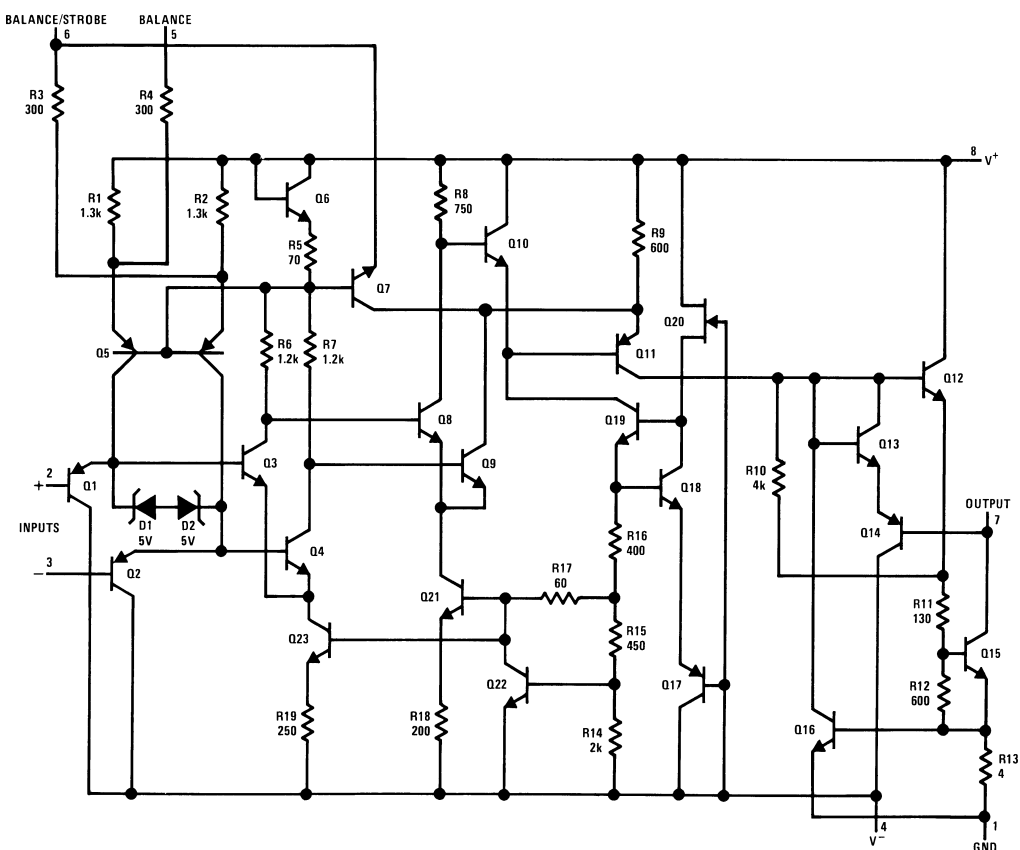


**Figure 4. Top View
Package Number NAC0010A, NAD0010A**



**Figure 5. Top View
Package Number NAJ0020A**

Schematic Diagram



Pin connections shown on schematic diagram are for LMC0008C package.

Figure 6.



These devices have limited built-in ESD protection. The leads should be shorted together or the device placed in conductive foam during storage or handling to prevent electrostatic damage to the MOS gates.

Absolute Maximum Ratings ⁽¹⁾

Positive Supply Voltage	+30.0V
Negative Supply Voltage	-30.0V
Total Supply Voltage	36V
Output to Negative Supply Voltage	50V
GND to Negative Supply Voltage	30V
Differential Input Voltage	±30V
Sink Current	50mA
Input Voltage ⁽²⁾	±15V
Power Dissipation ⁽³⁾	
8 LD CDIP	400mW at 25°C
8 LD TO-99	330mW at 25°C
10 LD CLGA	330mW at 25°C
10 LD CLGA	330mW at 25°C
20 LD LCCC	500mW at 25°C
Output Short Circuit Duration	10 seconds
Maximum Strobe Current	10mA
Operating Temperature Range	-55°C ≤ T _A ≤ 125°C
Thermal Resistance	
θ_{JA}	
8 LD CDIP (Still Air at 0.5W)	134°C/W
8 LD CDIP (500LF/Min Air flow at 0.5W)	76°C/W
8 LD TO-99 (Still Air at 0.5W)	162°C/W
8 LD TO-99 (500LF/Min Air flow at 0.5W)	92°C/W
10 LD CLGA (Still Air at 0.5W)	231°C/W
10 LD CLGA (500LF/Min Air flow at 0.5W)	153°C/W
10 LD CLGA (Still Air at 0.5W)	231°C/W
10 LD CLGA (500LF/Min Air flow at 0.5W)	153°C/W
14 LD CDIP (Still Air at 0.5W)	97°C/W
14 LD CDIP (500LF/Min Air flow at 0.5W)	65°C/W
20 LD LCCC (Still Air at 0.5W)	90°C/W
20 LD LCCC (500LF/Min Air flow at 0.5W)	65°C/W
θ_{Jc}	
8 LD CDIP	21°C/W
8 LD TO-99	50°C/W
10 LD CLGA	24°C/W
10 LD CLGA	24°C/W
14 LD CDIP	20°C/W
20 LD LCCC	21°C/W

- (1) Absolute Maximum Ratings indicate limits beyond which damage to the device may occur. Operating Ratings indicate conditions for which the device is functional, but do not ensure specific performance limits. For specifications and test conditions, see the Electrical Characteristics tables. The specifications apply only for the test conditions listed. Some performance characteristics may degrade when the device is not operated under the listed test conditions.
- (2) This rating applies for ±15V supplies. The positive input voltage limits is 30 V above the negative supply. The negative input voltage limits is equal to the negative supply voltage or 30V below the positive supply, whichever is less.
- (3) The maximum power dissipation must be derated at elevated temperatures and is dictated by T_{Jmax} (maximum junction temperature), θ_{JA} (package junction to ambient thermal resistance), and T_A (ambient temperature). The maximum allowable power dissipation at any temperature is P_{Dmax} = (T_{Jmax} - T_A)/θ_{JA} or the number given in the Absolute Maximum Ratings, whichever is lower.

Absolute Maximum Ratings ⁽¹⁾ (continued)

Storage Temperature Range	$-65^{\circ}\text{C} \leq T_A \leq 150^{\circ}\text{C}$
Maximum Junction Temperature	175°C
Lead Temperature (Soldering, 60 seconds)	300°C
Voltage at Strobe Pin	$V^+ = -5\text{V}$
Package Weight (Typical)	
8 LD TO-99	965mg
8 LD CDIP	1100mg
10 LD CLGA	250mg
10 LD CLGA	225mg
14 LD CDIP	TBD
20 LD LCCC	TBD
ESD Rating ⁽⁴⁾	300V

(4) Human body model, 1.5 kΩ in series with 100 pF.

Recommended Operating Conditions

Supply Voltage	$V_{CC} = \pm 15V_{DC}$
Operating Temperature Range	$-55^{\circ}\text{C} \leq T_A \leq 125^{\circ}\text{C}$

Quality Conformance Inspection
Table 1. Mil-Std-883, Method 5005 - Group A

Subgroup	Description	Temperature (°C)
1	Static tests at	+25
2	Static tests at	+125
3	Static tests at	-55
4	Dynamic tests at	+25
5	Dynamic tests at	+125
6	Dynamic tests at	-55
7	Functional tests at	+25
8A	Functional tests at	+125
8B	Functional tests at	-55
9	Switching tests at	+25
10	Switching tests at	+125
11	Switching tests at	-55

LM111/883 Electrical Characteristics DC Parameters⁽¹⁾

The following conditions apply, unless otherwise specified. $V_{56} = 0$, $R_S = 0 \Omega$, $V_{CC} = \pm 15V$, $V_{CM} = 0$, $V_O = 1.4V$ WRT $-V_{CC}$
The pin assignments are based on the 8 pin package configuration. ⁽²⁾

Symbol	Parameter	Conditions	Notes	Min	Max	Unit	Sub-groups
I_{IO}	Input Offset Current	$V_{CM} = 13.5V$, $R_S = 50K\Omega$		-10	10	nA	1
				-20	20	nA	2, 3
		$V_{CM} = 13.5V$, $V_{85} = V_{86} = 0V$, $R_S = 50K\Omega$	(2)	-30	30	nA	1
				-10	10	nA	1
		$V_{CM} = -14.5V$, $R_S = 50K\Omega$		-10	10	nA	1
				-20	20	nA	2, 3
		$V_{CM} = -14.5V$, $V_{85} = V_{86} = 0V$, $R_S = 50K\Omega$	(2)	-30	30	nA	1
I_{IB}	Input Bias Current	$V_{CM} = 13.5V$, $R_S = 50K\Omega$			100	nA	1
					150	nA	2, 3
		$V_{CM} = -14.5V$, $R_S = 50K\Omega$			100	nA	1
					150	nA	2, 3
		$R_S = 50K\Omega$			100	nA	1
					150	nA	2, 3
		$V_{85} = V_{86} = 0V$, $R_S = 50K\Omega$	(2)	-30	30	nA	1
I_{OL}	Output Leakage Current	$V_{CC} = \pm 18V$, $I_5 + I_6 = 5mA$, $V_O = 35V$ WRT $-V_{CC}$	(2)		10	nA	1
			(2)		500	nA	2, 3
I_{GL}	Ground Leakage Current	$V_{CC} = \pm 18V$, $I_5 + I_6 = 5mA$, $V_O = 50V$ WRT $-V_{CC}$	(2)		25	nA	1
			(2)		500	nA	2
V_{Sat}	Saturation Voltage	$V_I = -5mV$, $I_7 = 50mA$	(2)		1.5	V	1, 2, 3
		$V_I = -6mV$, $I_7 = 8mA$	(2)		0.4	V	1, 2, 3
$-I_{CC}$	Negative Supply Current				5.0	mA	1, 2
					15	mA	3
$+I_{CC}$	Positive Supply Current				6.0	mA	1, 2
					15	mA	3
I_{L1}	Input Leakage Current	$V_{CC} = \pm 18V$, $V_{28} = 1V$, $V_{38} = 30V$, $I_5 + I_6 = 5mA$, $V_O = 50V$ WRT $-V_{CC}$	(2)		10	nA	1
			(2)		30	nA	2
I_{L2}	Input Leakage Current	$V_{CC} = \pm 18V$, $V_{38} = 1V$, $V_{28} = 30V$, $I_5 + I_6 = 5mA$, $V_O = 50V$ WRT $-V_{CC}$	(2)		10	nA	1
			(2)		30	nA	2
V_{OSt}	Collector Output Voltage (Strobe)	$I_{St} = 3mA$		14		V	1
				14		V	1

(1) Calculated parameter.

(2) Pin names based on an 8 pin package configuration. When using higher pin count packages then: Pin 2 & 3 are Inputs, Pin 5 is Balance, Pin 6 is Balance /Strobe, Pin 7 is Output, and Pin 8 is V^+ . For example: V_{56} is the Voltage between the Balance and Balance / Strobe pins.

LM111/883 Electrical Characteristics DC Parameters⁽¹⁾ (continued)

The following conditions apply, unless otherwise specified. $V_{56} = 0$, $R_S = 0 \Omega$, $V_{CC} = \pm 15V$, $V_{CM} = 0$, $V_O = 1.4V$ WRT $-V_{CC}$
 The pin assignments are based on the 8 pin package configuration. ⁽²⁾

Symbol	Parameter	Conditions	Notes	Min	Max	Unit	Sub-groups
V_{IO}	Input Offset Voltage	$V_{CM} = 13.5V$		-3.0	3.0	mV	1
				-4.0	4.0	mV	2, 3
		$V_{CM} = 13.5V, V_{85} = V_{86} = 0V$	⁽²⁾	-3.0	3.0	mV	1
				-3.0	3.0	mV	1
		$V_{CM} = -14.5V$		-3.0	3.0	mV	1
				-4.0	4.0	mV	2, 3
		$V_{CM} = -14.5V, V_{85} = V_{86} = 0V$	⁽²⁾	-3.0	3.0	mV	1
				-3.0	3.0	mV	1
				-4.0	4.0	mV	2, 3
		$V_{85} = V_{86} = 0V$	⁽²⁾	-3.0	3.0	mV	1
		$V_O = 0.4V, +V_{CC} = 4.5V,$ $-V_{CC} = 0V, V_{CM} = 3V$		-5.0	5.0	mV	1
				-6.0	6.0	mV	2, 3
$V_O = 4.5V, +V_{CC} = 4.5V,$ $-V_{CC} = 0V, V_{CM} = 3V$		-3.0	3.0	mV	1		
		-4.0	4.0	mV	2, 3		
$V_O = 0.4V, +V_{CC} = 4.5V,$ $-V_{CC} = 0V, V_{CM} = 0.5V$		-5.0	5.0	mV	1		
		-6.0	6.0	mV	2, 3		
$V_O = 4.5V, +V_{CC} = 4.5V,$ $-V_{CC} = 0V, V_{CM} = 0.5V$		-3.0	3.0	mV	1		
		-4.0	4.0	mV	2, 3		
A_{VS}	Large Signal Gain	$-12V \leq V_O \leq 35V, R_L = 1K\Omega$	⁽³⁾	40		V/mV	4
			⁽³⁾	30		V/mV	5, 6

(3) Datalog reading in $K=V/mV$.

LM111/883 Electrical Characteristics AC Parameters⁽¹⁾

The following conditions apply, unless otherwise specified. $V_{56} = 0$, $R_S = 0 \Omega$, $V_{CC} = \pm 15V$, $V_{CM} = 0$, $V_O = 1.4V$ WRT $-V_{CC}$
 The pin assignments are based on the 8 pin package configuration. ⁽²⁾

Symbol	Parameter	Conditions	Notes	Min	Max	Unit	Sub-groups
tR	Response Time				400	nS	7

(1) Calculated parameter.

(2) Pin names based on an 8 pin package configuration. When using higher pin count packages then: Pin 2 & 3 are Inputs, Pin 5 is Balance, Pin 6 is Balance /Strobe, Pin 7 is Output, and Pin 8 is V^* . For example: V_{56} is the Voltage between the Balance and Balance / Strobe pins.

LM111-SMD Electrical Characteristics SMD 5962-8687701 DC Parameters⁽¹⁾

The following conditions apply, unless otherwise specified. $V_{CC} = \pm 15V, V_{CM} = 0$

Symbol	Parameter	Conditions	Notes	Min	Max	Unit	Sub-groups
V_{IO}	Input Offset Voltage	$V_I = 0V, R_S = 50\Omega$		-3.0	+3.0	mV	1
				-4.0	+4.0	mV	2, 3
		$+V_{CC} = 29.5V, -V_{CC} = -0.5V,$ $V_I = 0V, V_{CM} = -14.5V,$ $R_S = 50\Omega$		-3.0	+3.0	mV	1
				-4.0	+4.0	mV	2, 3
		$+V_{CC} = 2V, -V_{CC} = -28V,$ $V_I = 0V, V_{CM} = +13V,$ $R_S = 50\Omega$		-3.0	+3.0	mV	1
				-4.0	+4.0	mV	2, 3
$+V_{CC} = +2.5V, -V_{CC} = -2.5V,$ $V_I = 0V,$ $R_S = 50\Omega$		-3.0	+3.0	mV	1		
		-4.0	+4.0	mV	2, 3		

(1) Calculated parameter.

LM111-SMD Electrical Characteristics SMD 5962-8687701 DC Parameters⁽¹⁾ (continued)

 The following conditions apply, unless otherwise specified. $V_{CC} = \pm 15V$, $V_{CM} = 0$

Symbol	Parameter	Conditions	Notes	Min	Max	Unit	Sub-groups
$V_{IO R}$	Raised Input Offset Voltage	$V_I = 0V$, $R_S = 50\Omega$	(2)	-3.0	+3.0	mV	1
				-4.5	+4.5	mV	2, 3
		$+V_{CC} = 29.5V$, $-V_{CC} = -0.5V$, $V_I = 0V$, $V_{CM} = -14.5V$, $R_S = 50\Omega$	(2)	-3	+3	mV	1
				-4.5	+4.5	mV	2, 3
$+V_{CC} = 2V$, $-V_{CC} = -28V$, $V_I = 0V$, $V_{CM} = +13V$, $R_S = 50\Omega$	(2)	-3.0	+3.0	mV	1		
		-4.5	+4.5	mV	2, 3		
I_{IO}	Input Offset Current	$V_I = 0V$, $R_S = 50K\Omega$		-10	+10	nA	1, 2
				-20	+20	nA	3
		$+V_{CC} = 29.5V$, $-V_{CC} = -0.5V$, $V_I = 0V$, $V_{CM} = -14.5V$, $R_S = 50K\Omega$		-10	+10	nA	1, 2
				-20	+20	nA	3
$+V_{CC} = 2V$, $-V_{CC} = -28V$, $V_I = 0V$, $V_{CM} = +13V$, $R_S = 50K\Omega$		-10	+10	nA	1, 2		
		-20	+20	nA	3		
$I_{IO R}$	Raised Input Offset Current	$V_I = 0V$, $R_S = 50K\Omega$	(2)	-25	+25	nA	1, 2
				-50	+50	nA	3
$\pm I_{IB}$	Input Bias Current	$V_I = 0V$, $R_S = 50K\Omega$		-100	0.1	nA	1, 2
				-150	0.1	nA	3
		$+V_{CC} = 29.5V$, $-V_{CC} = -0.5V$, $V_I = 0V$, $V_{CM} = -14.5V$, $R_S = 50K\Omega$		-150	0.1	nA	1, 2
				-200	0.1	nA	3
$+V_{CC} = 2V$, $-V_{CC} = -28V$, $V_I = 0V$, $V_{CM} = +13V$, $R_S = 50K\Omega$		-150	0.1	nA	1, 2		
		-200	0.1	nA	3		
V_{OSt}	Collector Output Voltage (Strobe)	$+V_I = Gnd$, $-V_I = 15V$, $I_{St} = -3mA$, $R_S = 50\Omega$		⁽³⁾⁽⁴⁾ 14		V	1, 2, 3
CMRR	Common Mode Rejection Ratio	$-28V \leq -V_{CC} \leq -0.5V$, $R_S = 50\Omega$, $2V \leq +V_{CC} \leq 29.5V$, $R_S = 50\Omega$, $-14.5V \leq V_{CM} \leq 13V$, $R_S = 50\Omega$		80		dB	1, 2, 3
V_{OL}	Low Level Output Voltage	$+V_{CC} = 4.5V$, $-V_{CC} = Gnd$, $I_O = 8mA$, $\pm V_I = 0.71V$, $V_{ID} = -6mV$			0.4	V	1, 2, 3
					0.4	V	1, 2, 3
		$I_O = 50mA$, $\pm V_I = 13V$, $V_{ID} = -5mV$			1.5	V	1, 2, 3
					1.5	V	1, 2, 3
I_{CEX}	Output Leakage Current	$+V_{CC} = 18V$, $-V_{CC} = -18V$, $V_O = 32V$		-1.0	10	nA	1
				-1.0	500	nA	2
I_L	Input Leakage Current	$+V_{CC} = 18V$, $-V_{CC} = -18V$, $+V_I = +12V$, $-V_I = -17V$	(5)	-5.0	500	nA	1, 2, 3
				$+V_{CC} = 18V$, $-V_{CC} = -18V$, $+V_I = -17V$, $-V_I = +12V$	(5)	-5.0	500
$+I_{CC}$	Power Supply Current				6.0	mA	1, 2
					7.0	mA	3

(2) Subscript (R) indicates tests which are performed with input stage current raised by connecting BAL and BAL/STB terminals to $+V_{CC}$.(3) $I_{ST} = -2mA$ at $-55^\circ C$

(4) Group A sample ONLY

(5) V_{ID} is voltage difference between inputs.

LM111-SMD Electrical Characteristics SMD 5962-8687701 DC Parameters⁽¹⁾ (continued)

 The following conditions apply, unless otherwise specified. $V_{CC} = \pm 15V$, $V_{CM} = 0$

Symbol	Parameter	Conditions	Notes	Min	Max	Unit	Sub-groups
-I _{CC}	Power Supply Current			-5.0		mA	1, 2
				-6.0		mA	3
$\Delta V_{IO} / \Delta T$	Temperature Coefficient Input Offset Voltage	25°C ≤ T ≤ 125°C	(5) (4)	-25	25	μV/°C	2
		-55°C ≤ T ≤ 25°C	(5) (4)	-25	25	μV/°C	3
$\Delta I_{IO} / \Delta T$	Temperature Coefficient Input Offset Current	25°C ≤ T ≤ 125°C	(5) (4)	-100	100	pA/°C	2
		-55°C ≤ T ≤ 25°C	(5) (4)	-200	200	pA/°C	3
I _{OS}	Short Circuit Current	V _O = 5V, t ≤ 10mS, -V _I = 0.1V, +V _I = 0V	(6)		200	mA	1
			(6)		150	mA	2
			(6)		250	mA	3
+V _{IO} adj.	Input Offset Voltage (Adjustment)	V _O = 0V, V _I = 0V, R _S = 50Ω		5.0		mV	1
-V _{IO} adj.	Input Offset Voltage (Adjustment)	V _O = 0V, V _I = 0V, R _S = 50Ω			-5.0	mV	1
±A _{VE}	Voltage Gain (Emitter)	R _L = 600Ω	(7)	10		V/mV	4
			(7)	8.0		V/mV	5, 6

(6) Actual min. limit used is 5mA due to test setup.

(7) Datalog reading in K=V/mV.

LM111-SMD Electrical Characteristics SMD 5962-8687701 AC Parameters⁽¹⁾

 The following conditions apply, unless otherwise specified. $V_{CC} = \pm 15V$, $V_{CM} = 0$

Symbol	Parameter	Conditions	Notes	Min	Max	Unit	Sub-groups
t _{R_LHC}	Response Time (Collector Output)	V _{OD} (Overdrive) = -5mV, C _L = 50pF, V _I = -100mV	(2)		300	nS	7, 8B
			(2)		640	nS	8A
t _{R_HLC}	Response Time (Collector Output)	V _{OD} (Overdrive) = 5mV, C _L = 50pF, V _I = 100mV	(2)		300	nS	7, 8B
			(2)		500	nS	8A

(1) Calculated parameter.

(2) Group A sample ONLY

LM111 RADIATION Electrical Characteristics SMD 5962L0052401 DC Parameters⁽¹⁾⁽²⁾

 The following conditions apply, unless otherwise specified. $V_{CC} = \pm 15V$, $V_{CM} = 0$

Symbol	Parameter	Conditions	Notes	Min	Max	Unit	Sub-groups
V _{IO}	Input Offset Voltage	V _I = 0V, R _S = 50Ω		-3.0	+3.0	mV	1
				-4.0	+4.0	mV	2, 3
		+V _{CC} = 29.5V, -V _{CC} = -0.5V, V _I = 0V, V _{CM} = -14.5V, R _S = 50Ω		-3.0	+3.0	mV	1
				-4.0	+4.0	mV	2, 3
		+V _{CC} = 2V, -V _{CC} = -28V, V _I = 0V, V _{CM} = +13V, R _S = 50Ω		-3.0	+3.0	mV	1
				-4.0	+4.0	mV	2, 3
+V _{CC} = +2.5V, -V _{CC} = -2.5V, V _I = 0V, R _S = 50Ω		-3.0	+3.0	mV	1		
		-4.0	+4.0	mV	2, 3		

(1) Calculated parameter.

(2) Pre and post irradiation limits are identical to those listed under AC and DC electrical characteristics except as listed in the Post Radiation Limits Table. These parts may be dose rate sensitive in a space environment and demonstrate enhanced low dose rate effect. Radiation end point limits for the noted parameters are ensured only for the conditions as specified in Mil-Std-883, Method 1019, Condition A.

LM111 RADIATION Electrical Characteristics SMD 5962L0052401 DC Parameters⁽¹⁾⁽²⁾ (continued)

 The following conditions apply, unless otherwise specified. $V_{CC} = \pm 15V$, $V_{CM} = 0$

Symbol	Parameter	Conditions	Notes	Min	Max	Unit	Sub-groups
$V_{IO R}$	Raised Input Offset Voltage	$V_I = 0V$, $R_S = 50\Omega$	(3)	-3.0	+3.0	mV	1
				-4.5	+4.5	mV	2, 3
		$+V_{CC} = 29.5V$, $-V_{CC} = -0.5V$, $V_I = 0V$, $V_{CM} = -14.5V$, $R_S = 50\Omega$	(3)	-3.0	+3.0	mV	1
				-4.5	+4.5	mV	2, 3
$+V_{CC} = 2V$, $-V_{CC} = -28V$, $V_I = 0V$, $V_{CM} = +13V$, $R_S = 50\Omega$	(3)	-3.0	+3.0	mV	1		
		-4.5	+4.5	mV	2, 3		
I_{IO}	Input Offset Current	$V_I = 0V$, $R_S = 50K\Omega$		-10	+10	nA	1, 2
				-20	+20	nA	3
		$+V_{CC} = 29.5V$, $-V_{CC} = -0.5V$, $V_I = 0V$, $V_{CM} = -14.5V$, $R_S = 50K\Omega$		-10	+10	nA	1, 2
				-20	+20	nA	3
$+V_{CC} = 2V$, $-V_{CC} = -28V$, $V_I = 0V$, $V_{CM} = +13V$, $R_S = 50K\Omega$		-10	+10	nA	1, 2		
		-20	+20	nA	3		
$I_{IO R}$	Raised Input Offset Current	$V_I = 0V$, $R_S = 50K\Omega$	(3)	-25	+25	nA	1, 2
				-50	+50	nA	3
$\pm I_{IB}$	Input Bias Current	$V_I = 0V$, $R_S = 50K\Omega$		-100	0.1	nA	1, 2
				-150	0.1	nA	3
		$+V_{CC} = 29.5V$, $-V_{CC} = -0.5V$, $V_I = 0V$, $V_{CM} = -14.5V$, $R_S = 50K\Omega$		-150	0.1	nA	1, 2
				-200	0.1	nA	3
$+V_{CC} = 2V$, $-V_{CC} = -28V$, $V_I = 0V$, $V_{CM} = +13V$, $R_S = 50K\Omega$		-150	0.1	nA	1, 2		
		-200	0.1	nA	3		
V_{OSt}	Collector Output Voltage (Strobe)	$+V_I = Gnd$, $-V_I = 15V$, $I_{ST} = -3mA$, $R_S = 50\Omega$		⁽⁴⁾⁽⁵⁾ 14		V	1, 2, 3
CMRR	Common Mode Rejection Ratio	$-28V \leq -V_{CC} \leq -0.5V$, $R_S = 50\Omega$, $2V \leq +V_{CC} \leq 29.5V$, $R_S = 50\Omega$, $-14.5V \leq V_{CM} \leq 13V$, $R_S = 50\Omega$		80		dB	1, 2, 3
V_{OL}	Low Level Output Voltage	$+V_{CC} = 4.5V$, $-V_{CC} = Gnd$, $I_O = 8mA$, $\pm V_I = 0.5V$, $V_{ID} = -6mV$			0.4	V	1, 2, 3
					0.4	V	1, 2, 3
		$I_O = 50mA$, $\pm V_I = 13V$, $V_{ID} = -5mV$			1.5	V	1, 2, 3
					1.5	V	1, 2, 3
I_{CEX}	Output Leakage Current	$+V_{CC} = 18V$, $-V_{CC} = -18V$, $V_O = 32V$		-1.0	10	nA	1
				-1.0	500	nA	2
I_L	Input Leakage Current	$+V_{CC} = 18V$, $-V_{CC} = -18V$, $+V_I = +12V$, $-V_I = -17V$	(6)	-5.0	500	nA	1, 2, 3
				$+V_{CC} = 18V$, $-V_{CC} = -18V$, $+V_I = -17V$, $-V_I = +12V$	(6)	-5.0	500
$+I_{CC}$	Power Supply Current				6.0	mA	1, 2
					7.0	mA	3

(3) Subscript (R) indicates tests which are performed with input stage current raised by connecting BAL and BAL/STB terminals to $+V_{CC}$.(4) $I_{ST} = -2mA$ at $-55^\circ C$

(5) Group A sample ONLY

(6) V_{ID} is voltage difference between inputs.

LM111 RADIATION Electrical Characteristics SMD 5962L0052401 DC Parameters⁽¹⁾⁽²⁾ (continued)

 The following conditions apply, unless otherwise specified. $V_{CC} = \pm 15V$, $V_{CM} = 0$

Symbol	Parameter	Conditions	Notes	Min	Max	Unit	Sub-groups
$-I_{CC}$	Power Supply Current			-5.0		mA	1, 2
				-6.0		mA	3
$\Delta V_{IO} / \Delta T$	Temperature Coefficient Input Offset Voltage	$25^{\circ}C \leq T \leq 125^{\circ}C$		-25	25	$\mu V/^{\circ}C$	2
		$-55^{\circ}C \leq T \leq 25^{\circ}C$		-25	25	$\mu V/^{\circ}C$	3
$\Delta I_{IO} / \Delta T$	Temperature Coefficient Input Offset Current	$25^{\circ}C \leq T \leq 125^{\circ}C$		-100	100	$pA/^{\circ}C$	2
		$-55^{\circ}C \leq T \leq 25^{\circ}C$		-200	200	$pA/^{\circ}C$	3
I_{OS}	Short Circuit Current	$V_O = 5V$, $t \leq 10mS$, $-V_I = 0.1V$, $+V_I = 0V$	(7)		200	mA	1
			(7)		150	mA	2
			(7)		250	mA	3
$+V_{IO}$ adj.	Input Offset Voltage (Adjustment)	$V_O = 0V$, $V_I = 0V$, $R_S = 50\Omega$		5.0		mV	1
$-V_{IO}$ adj.	Input Offset Voltage (Adjustment)	$V_O = 0V$, $V_I = 0V$, $R_S = 50\Omega$			-5.0	mV	1
$\pm A_{VE}$	Voltage Gain (Emitter)	$R_L = 600\Omega$	(8)	10		V/mV	4
			(8)	8.0		V/mV	5, 6

(7) Actual min. limit used is 5mA due to test setup.

 (8) Datalog reading in $K=V/mV$.

LM111 RADIATION Electrical Characteristics SMD 5962L0052401 AC Parameters⁽¹⁾⁽²⁾

 The following conditions apply, unless otherwise specified. $V_{CC} = \pm 15V$, $V_{CM} = 0$

Symbol	Parameter	Conditions	Notes	Min	Max	Unit	Sub-groups
t_{RLHC}	Response Time (Collector Output)	$V_{OD}(\text{Overdrive}) = -5mV$, $C_L = 50pF$, $V_I = -100mV$	(3)		300	nS	7, 8B
					640	nS	8A
t_{RHLC}	Response Time (Collector Output)	$V_{OD}(\text{Overdrive}) = 5mV$, $C_L = 50pF$, $V_I = 100mV$	(3)		300	nS	7, 8B
					500	nS	8A

(1) Calculated parameter.

(2) Pre and post irradiation limits are identical to those listed under AC and DC electrical characteristics except as listed in the Post Radiation Limits Table. These parts may be dose rate sensitive in a space environment and demonstrate enhanced low dose rate effect. Radiation end point limits for the noted parameters are ensured only for the conditions as specified in Mil-Std-883, Method 1019, Condition A.

(3) Group A sample ONLY

LM111 RADIATION Electrical Characteristics SMD 5962L0052401 DC DELTA Parameters⁽¹⁾⁽²⁾

 The following conditions apply, unless otherwise specified. $V_{CC} = \pm 15V$, $V_{CM} = 0$

Delta calculations performed on QMLV devices at group B , subgroup 5.

Symbol	Parameter	Conditions	Notes	Min	Max	Unit	Sub-groups
V_{IO}	Input Offset Voltage	$V_I = 0V$, $R_S = 50\Omega$		-0.5	0.5	mV	1
		$+V_{CC} = 29.5V$, $-V_{CC} = -0.5V$, $V_I = 0V$, $V_{CM} = -14.5V$, $R_S = 50\Omega$		-0.5	0.5	mV	1
		$+V_{CC} = 2V$, $-V_{CC} = -28V$, $V_I = 0V$, $V_{CM} = +13V$, $R_S = 50\Omega$		-0.5	0.5	mV	1

(1) Calculated parameter.

(2) Pre and post irradiation limits are identical to those listed under AC and DC electrical characteristics except as listed in the Post Radiation Limits Table. These parts may be dose rate sensitive in a space environment and demonstrate enhanced low dose rate effect. Radiation end point limits for the noted parameters are ensured only for the conditions as specified in Mil-Std-883, Method 1019, Condition A.

LM111 RADIATION Electrical Characteristics SMD 5962L0052401 DC DELTA Parameters⁽¹⁾⁽²⁾ (continued)

The following conditions apply, unless otherwise specified. $V_{CC} = \pm 15V$, $V_{CM} = 0$
Delta calculations performed on QMLV devices at group B , subgroup 5.

Symbol	Parameter	Conditions	Notes	Min	Max	Unit	Sub-groups
$\pm I_{IB}$	Input Bias Current	$V_I = 0V$, $R_S = 50K\Omega$		-12.5	12.5	nA	1
		$+V_{CC} = 29.5V$, $-V_{CC} = -0.5V$, $V_I = 0V$, $V_{CM} = -14.5V$, $R_S = 50K\Omega$		-12.5	12.5	nA	1
		$+V_{CC} = 2V$, $-V_{CC} = -28V$, $V_I = 0V$, $V_{CM} = +13V$, $R_S = 50K\Omega$		-12.5	12.5	nA	1
I_{CEX}	Output Leakage Current	$+V_{CC} = 18V$, $-V_{CC} = -18V$, $V_O = 32V$		-5.0	5.0	nA	1

LM111 RADIATION Electrical Characteristics SMD 5962L0052401 Post Radiation Parameters⁽¹⁾⁽²⁾

The following conditions apply, unless otherwise specified

Symbol	Parameter	Conditions	Notes	Min	Max	Unit	Sub-groups
I_{IO}	Input Offset Current	$+V_{CC} = 29.5V$, $-V_{CC} = -0.5V$, $V_I = 0V$, $V_{CM} = -14.5V$, $R_S = 50K\Omega$		-50	+50	nA	1
		$+V_{CC} = 2V$, $-V_{CC} = -28V$, $V_I = 0V$, $V_{CM} = +13V$, $R_S = 50K\Omega$		-50	+50	nA	1
$\pm I_{IB}$	Input Bias Current	$V_I = 0V$, $R_S = 50K\Omega$		-150	0.1	nA	1
		$+V_{CC} = 29.5V$, $-V_{CC} = -0.5V$, $V_I = 0V$, $V_{CM} = -14.5V$, $R_S = 50K\Omega$		-175	0.1	nA	1
I_{CEX}	Output Leakage Current	$+V_{CC} = 18V$, $-V_{CC} = -18V$, $V_O = 32V$		-25	+25	nA	1

(1) Calculated parameter.

(2) Pre and post irradiation limits are identical to those listed under AC and DC electrical characteristics except as listed in the Post Radiation Limits Table. These parts may be dose rate sensitive in a space environment and demonstrate enhanced low dose rate effect. Radiation end point limits for the noted parameters are ensured only for the conditions as specified in Mil-Std-883, Method 1019, Condition A.

LM111 RADIATION Electrical Characteristics SMD 5962R0052402 DC Parameters⁽¹⁾⁽²⁾

The following conditions apply, unless otherwise specified. $V_{CC} = \pm 15V$, $V_{CM} = 0$

Symbol	Parameter	Conditions	Notes	Min	Max	Unit	Sub-groups
V_{IO}	Input Offset Voltage	$V_I = 0V$, $R_S = 50\Omega$		-3.0	+3.0	mV	1
				-4.0	+4.0	mV	2, 3
		$+V_{CC} = 29.5V$, $-V_{CC} = -0.5V$, $V_I = 0V$, $V_{CM} = -14.5V$, $R_S = 50\Omega$		-3.0	+3.0	mV	1
				-4.0	+4.0	mV	2, 3
		$+V_{CC} = 2V$, $-V_{CC} = -28V$, $V_I = 0V$, $V_{CM} = +13V$, $R_S = 50\Omega$		-3.0	+3.0	mV	1
				-4.0	+4.0	mV	2, 3
$+V_{CC} = +2.5V$, $-V_{CC} = -2.5V$, $V_I = 0V$, $R_S = 50\Omega$		-3.0	+3.0	mV	1		
		-4.0	+4.0	mV	2, 3		

(1) Calculated parameter.

(2) Pre and post irradiation limits are identical to those listed under AC and DC electrical characteristics except as listed in the Post Radiation Limits Table. These parts may be sensitive in a high dose environment. Low dose rate testing has been performed on a wafer-by-wafer basis, per test method 1019 condition D of MIL-STD-883, with no enhanced low dose rate sensitivity (ELDRS) effect.

LM111 RADIATION Electrical Characteristics SMD 5962R0052402 DC Parameters⁽¹⁾⁽²⁾ (continued)

 The following conditions apply, unless otherwise specified. $V_{CC} = \pm 15V$, $V_{CM} = 0$

Symbol	Parameter	Conditions	Notes	Min	Max	Unit	Sub-groups
$V_{IO R}$	Raised Input Offset Voltage	$V_I = 0V$, $R_S = 50\Omega$	(2)	-3.0	+3.0	mV	1
				-4.5	+4.5	mV	2, 3
		$+V_{CC} = 29.5V$, $-V_{CC} = -0.5V$, $V_I = 0V$, $V_{CM} = -14.5V$, $R_S = 50\Omega$	(2)	-3.0	+3.0	mV	1
				-4.5	+4.5	mV	2, 3
		$+V_{CC} = 2V$, $-V_{CC} = -28V$, $V_I = 0V$, $V_{CM} = +13V$, $R_S = 50\Omega$	(2)	-3.0	+3.0	mV	1
				-4.5	+4.5	mV	2, 3
I_{IO}	Input Offset Current	$V_I = 0V$, $R_S = 50K\Omega$		-10	+10	nA	1, 2
				-20	+20	nA	3
		$+V_{CC} = 29.5V$, $-V_{CC} = -0.5V$, $V_I = 0V$, $V_{CM} = -14.5V$, $R_S = 50K\Omega$		-10	+10	nA	1, 2
				-20	+20	nA	3
		$+V_{CC} = 2V$, $-V_{CC} = -28V$, $V_I = 0V$, $V_{CM} = +13V$, $R_S = 50K\Omega$		-10	+10	nA	1, 2
				-20	+20	nA	3
$I_{IO R}$	Raised Input Offset Current	$V_I = 0V$, $R_S = 50K\Omega$	(2)	-25	+25	nA	1, 2
				-50	+50	nA	3
$\pm I_{IB}$	Input Bias Current	$V_I = 0V$, $R_S = 50K\Omega$		-100	0.1	nA	1, 2
				-150	0.1	nA	3
		$+V_{CC} = 29.5V$, $-V_{CC} = -0.5V$, $V_I = 0V$, $V_{CM} = -14.5V$, $R_S = 50K\Omega$		-150	0.1	nA	1, 2
				-200	0.1	nA	3
		$+V_{CC} = 2V$, $-V_{CC} = -28V$, $V_I = 0V$, $V_{CM} = +13V$, $R_S = 50K\Omega$		-150	0.1	nA	1, 2
				-200	0.1	nA	3
V_{OSt}	Collector Output Voltage (Strobe)	$+V_I = Gnd$, $-V_I = 15V$, $I_{St} = -3mA$, $R_S = 50\Omega$		⁽³⁾⁽⁴⁾ 14		V	1, 2, 3
CMRR	Common Mode Rejection Ratio	$-28V \leq -V_{CC} \leq -0.5V$, $R_S = 50\Omega$, $2V \leq +V_{CC} \leq 29.5V$, $R_S = 50\Omega$, $-14.5V \leq V_{CM} \leq 13V$, $R_S = 50\Omega$		80		dB	1, 2, 3
V_{OL}	Low Level Output Voltage	$+V_{CC} = 4.5V$, $-V_{CC} = Gnd$, $I_O = 8mA$, $\pm V_I = 0.5V$, $V_{ID} = -6mV$			0.4	V	1, 2, 3
					0.4	V	1, 2, 3
		$I_O = 50mA$, $\pm V_I = 13V$, $V_{ID} = -5mV$			1.5	V	1, 2, 3
					1.5	V	1, 2, 3
I_{CEX}	Output Leakage Current	$+V_{CC} = 18V$, $-V_{CC} = -18V$, $V_O = 32V$		-1.0	10	nA	1
				-1.0	500	nA	2
I_L	Input Leakage Current	$+V_{CC} = 18V$, $-V_{CC} = -18V$, $+V_I = +12V$, $-V_I = -17V$	(5)	-5.0	500	nA	1, 2, 3
				$+V_{CC} = 18V$, $-V_{CC} = -18V$, $+V_I = -17V$, $-V_I = +12V$	(5)	-5.0	500
$+I_{CC}$	Power Supply Current				6.0	mA	1, 2
					7.0	mA	3
$-I_{CC}$	Power Supply Current			-5.0		mA	1, 2
				-6.0		mA	3

 (3) $I_{ST} = -2mA$ at $-55^\circ C$

(4) Group A sample ONLY

 (5) V_{ID} is voltage difference between inputs.

LM111 RADIATION Electrical Characteristics SMD 5962R0052402 DC Parameters⁽¹⁾⁽²⁾ (continued)

The following conditions apply, unless otherwise specified. $V_{CC} = \pm 15V$, $V_{CM} = 0$

Symbol	Parameter	Conditions	Notes	Min	Max	Unit	Sub-groups
$\Delta V_{IO} / \Delta T$	Temperature Coefficient Input Offset Voltage	$25^{\circ}C \leq T \leq 125^{\circ}C$		-25	25	$\mu V/^{\circ}C$	2
		$-55^{\circ}C \leq T \leq 25^{\circ}C$		-25	25	$\mu V/^{\circ}C$	3
$\Delta I_{IO} / \Delta T$	Temperature Coefficient Input Offset Current	$25^{\circ}C \leq T \leq 125^{\circ}C$		-100	100	$\mu A/^{\circ}C$	2
		$-55^{\circ}C \leq T \leq 25^{\circ}C$		-200	200	$\mu A/^{\circ}C$	3
I_{OS}	Short Circuit Current	$V_O = 5V$, $t \leq 10mS$, $-V_I = 0.1V$, $+V_I = 0V$	(6)		200	mA	1
			(5)		150	mA	2
			(5)		250	mA	3
+ V_{IO} adj.	Input Offset Voltage (Adjustment)	$V_O = 0V$, $V_I = 0V$, $R_S = 50\Omega$		5.0		mV	1
- V_{IO} adj.	Input Offset Voltage (Adjustment)	$V_O = 0V$, $V_I = 0V$, $R_S = 50\Omega$			-5.0	mV	1
$\pm A_{VE}$	Voltage Gain (Emitter)	$R_L = 600\Omega$	(7)	10		V/mV	4
			(7)	8.0		V/mV	5, 6

(6) Actual min. limit used is 5mA due to test setup.

(7) Pin names based on an 8 pin package configuration. When using higher pin count packages then: Pin 2 & 3 are Inputs, Pin 5 is Balance, Pin 6 is Balance /Strobe, Pin 7 is Output, and Pin 8 is V^* . For example: V_{56} is the Voltage between the Balance and Balance / Strobe pins.

LM111 RADIATION Electrical Characteristics SMD 5962R0052402 AC Parameters⁽¹⁾⁽²⁾

The following conditions apply, unless otherwise specified. $V_{CC} = \pm 15V$, $V_{CM} = 0$

Symbol	Parameter	Conditions	Notes	Min	Max	Unit	Sub-groups
t_{RLHC}	Response Time (Collector Output)	$V_{OD}(\text{Overdrive}) = -5mV$, $C_L = 50pF$, $V_I = -100mV$	(3)		300	nS	7, 8B
					640	nS	8A
t_{RHLC}	Response Time (Collector Output)	$V_{OD}(\text{Overdrive}) = 5mV$, $C_L = 50pF$, $V_I = 100mV$	(3)		300	nS	7, 8B
					500	nS	8A

(1) Calculated parameter.

(2) Pre and post irradiation limits are identical to those listed under AC and DC electrical characteristics except as listed in the Post Radiation Limits Table. These parts may be sensitive in a high dose environment. Low dose rate testing has been performed on a wafer-by-wafer basis, per test method 1019 condition D of MIL-STD-883, with no enhanced low dose rate sensitivity (ELDRS) effect.

(3) Group A sample ONLY

LM111 RADIATION Electrical Characteristics SMD 5962R0052402 DC DELTA Parameters⁽¹⁾⁽²⁾

The following conditions apply, unless otherwise specified. $V_{CC} = \pm 15V$, $V_{CM} = 0$

Delta calculations performed on QMLV devices at group B , subgroup 5.

Symbol	Parameter	Conditions	Notes	Min	Max	Unit	Sub-groups
V_{IO}	Input Offset Voltage	$V_I = 0V$, $R_S = 50\Omega$		-0.5	0.5	mV	1
		$+V_{CC} = 29.5V$, $-V_{CC} = -0.5V$, $V_I = 0V$, $V_{CM} = -14.5V$, $R_S = 50\Omega$		-0.5	0.5	mV	1
		$+V_{CC} = 2V$, $-V_{CC} = -28V$, $V_I = 0V$, $V_{CM} = +13V$, $R_S = 50\Omega$		-0.5	0.5	mV	1

(1) Calculated parameter.

(2) Pre and post irradiation limits are identical to those listed under AC and DC electrical characteristics except as listed in the Post Radiation Limits Table. These parts may be sensitive in a high dose environment. Low dose rate testing has been performed on a wafer-by-wafer basis, per test method 1019 condition D of MIL-STD-883, with no enhanced low dose rate sensitivity (ELDRS) effect.

LM111 RADIATION Electrical Characteristics SMD 5962R0052402 DC DELTA Parameters⁽¹⁾⁽²⁾ (continued)

The following conditions apply, unless otherwise specified. $V_{CC} = \pm 15V$, $V_{CM} = 0$
Delta calculations performed on QMLV devices at group B , subgroup 5.

Symbol	Parameter	Conditions	Notes	Min	Max	Unit	Sub-groups
$\pm I_{IB}$	Input Bias Current	$V_I = 0V$, $R_S = 50K\Omega$		-12.5	12.5	nA	1
		$+V_{CC} = 29.5V$, $-V_{CC} = -0.5V$, $V_I = 0V$, $V_{CM} = -14.5V$, $R_S = 50K\Omega$		-12.5	12.5	nA	1
		$+V_{CC} = 2V$, $-V_{CC} = -28V$, $V_I = 0V$, $V_{CM} = +13V$, $R_S = 50K\Omega$		-12.5	12.5	nA	1
I_{CEX}	Output Leakage Current	$+V_{CC} = 18V$, $-V_{CC} = -18V$, $V_O = 32V$		-5.0	5.0	nA	1

LM111 RADIATION Electrical Characteristics SMD 5962R0052402 Post Radiation Parameters⁽¹⁾⁽²⁾

The following conditions apply, unless otherwise specified

Symbol	Parameter	Conditions	Notes	Min	Max	Unit	Sub-groups
$I_{IO(R)}$	Raised Input Offset Current	$V_I = 0V$, $R_S = 50K\Omega$	(3)	-100	+100	nA	1
$\pm I_{IB}$	Input Bias Current	$V_I = 0V$, $R_S = 50K\Omega$		-180	0.1	nA	1
		$+V_{CC} = 29.5V$, $-V_{CC} = -0.5V$, $V_I = 0V$, $V_{CM} = -14.5V$, $R_S = 50K\Omega$		-225	0.1	nA	1
I_{CEX}	Output Leakage Current	$+V_{CC} = 18V$, $-V_{CC} = -18V$, $V_O = 32V$		-1.0	+25	nA	1

(1) Calculated parameter.

(2) Pre and post irradiation limits are identical to those listed under AC and DC electrical characteristics except as listed in the Post Radiation Limits Table. These parts may be sensitive in a high dose environment. Low dose rate testing has been performed on a wafer-by-wafer basis, per test method 1019 condition D of MIL-STD-883, with no enhanced low dose rate sensitivity (ELDRS) effect.

(3) Subscript (R) indicates tests which are performed with input stage current raised by connecting BAL and BAL/STB terminals to $+V_{CC}$.

LM111 Typical Performance Characteristics

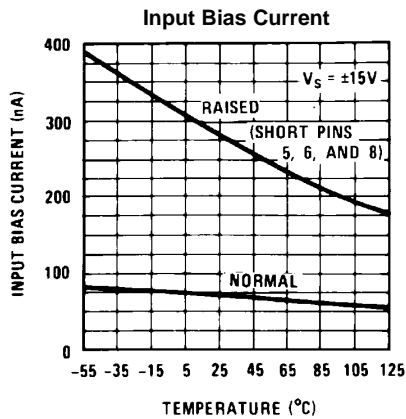


Figure 7.

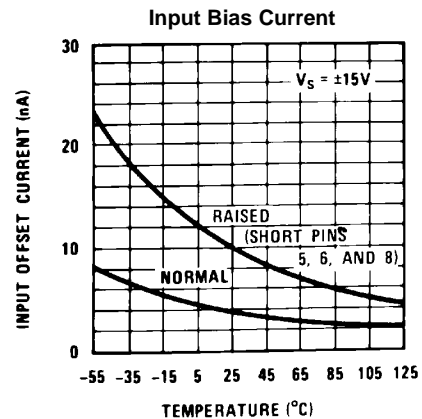


Figure 8.

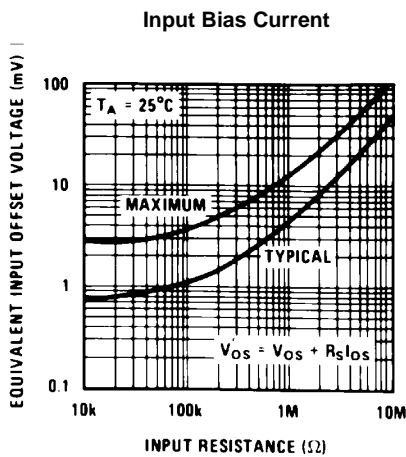


Figure 9.

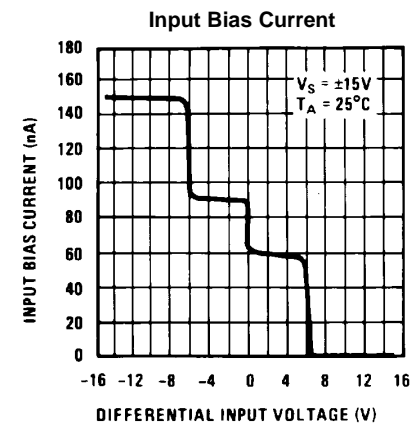


Figure 10.

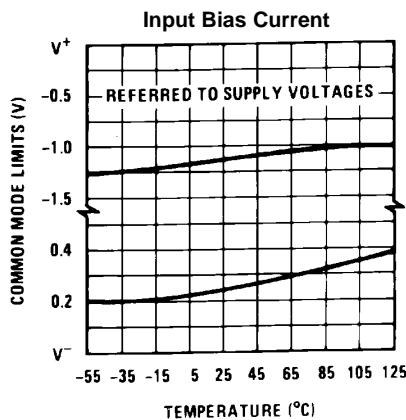


Figure 11.

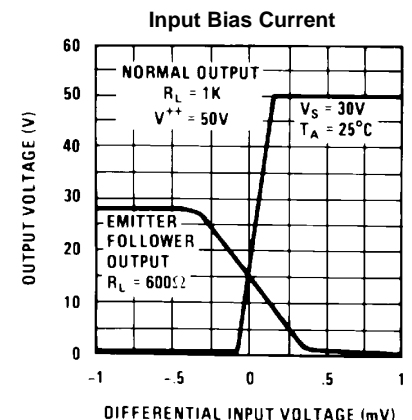


Figure 12.

LM111 Typical Performance Characteristics (continued)
Input Bias Current
Input Overdrives

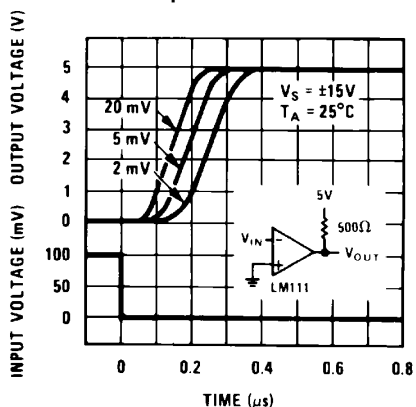


Figure 13.

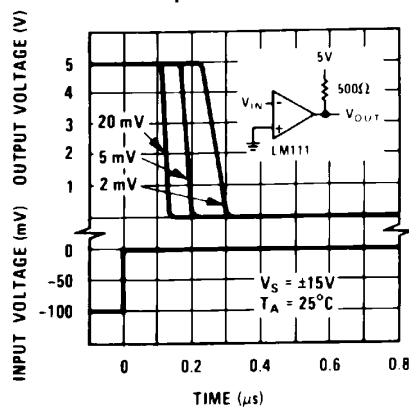


Figure 14.

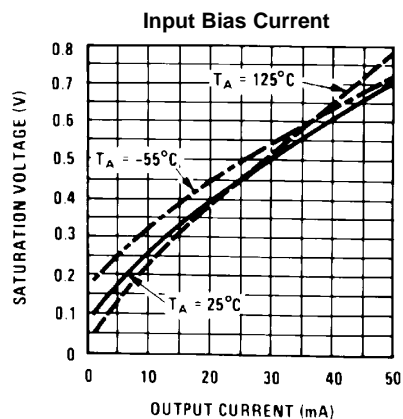


Figure 15.

Response Time for Various
Input Overdrives

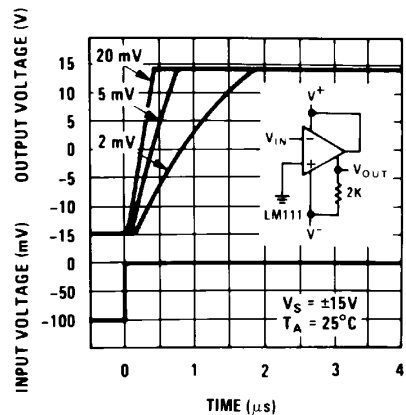


Figure 16.

Response Time for Various
Input Overdrives

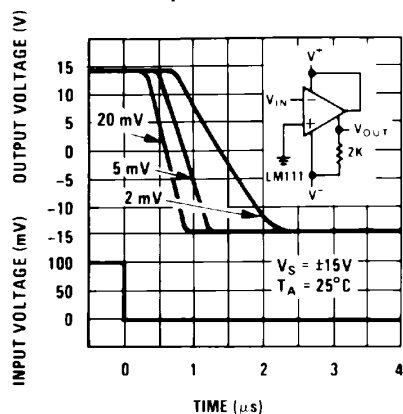


Figure 17.

Output Limiting Characteristics

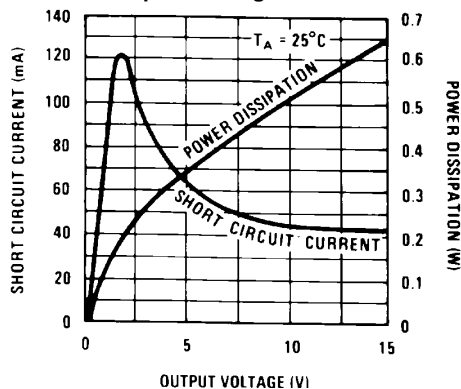


Figure 18.

LM111 Typical Performance Characteristics (continued)

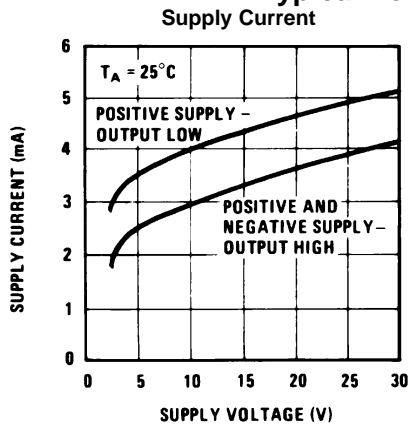


Figure 19.

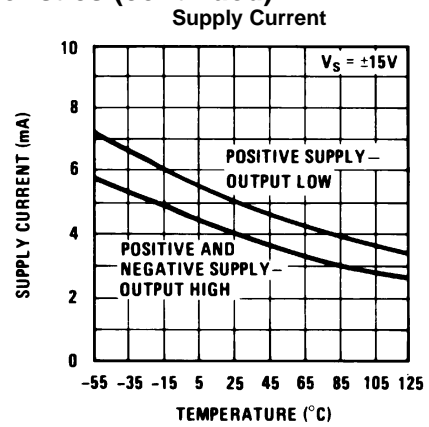


Figure 20.

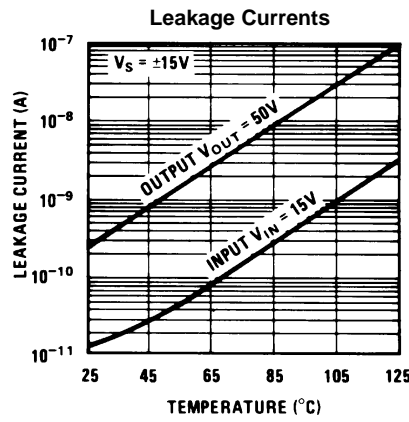


Figure 21.

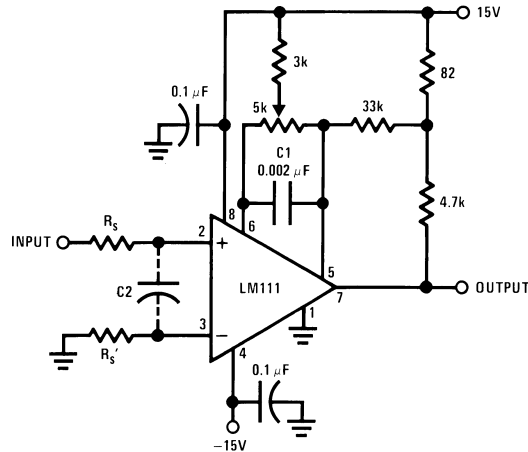
APPLICATION HINTS

CIRCUIT TECHNIQUES FOR AVOIDING OSCILLATIONS IN COMPARATOR APPLICATIONS

When a high-speed comparator such as the LM111 is used with fast input signals and low source impedances, the output response will normally be fast and stable, assuming that the power supplies have been bypassed (with 0.1 μF disc capacitors), and that the output signal is routed well away from the inputs (pins 2 and 3) and also away from pins 5 and 6.

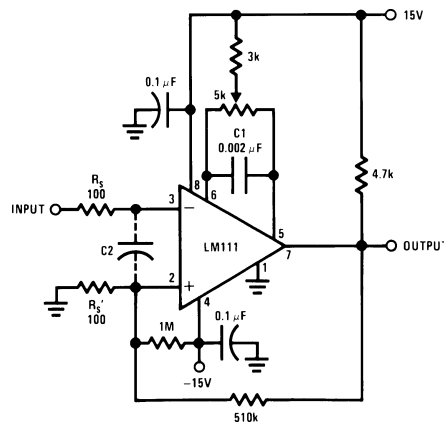
However, when the input signal is a voltage ramp or a slow sine wave, or if the signal source impedance is high (1 $\text{k}\Omega$ to 100 $\text{k}\Omega$), the comparator may burst into oscillation near the crossing-point. This is due to the high gain and wide bandwidth of comparators like the LM111. To avoid oscillation or instability in such a usage, several precautions are recommended, as shown in [Figure 22](#) below.

1. The trim pins (pins 5 and 6) act as unwanted auxiliary inputs. If these pins are not connected to a trim-pot, they should be shorted together. If they are connected to a trim-pot, a 0.01 μF capacitor C1 between pins 5 and 6 will minimize the susceptibility to AC coupling. A smaller capacitor is used if pin 5 is used for positive feedback as in [Figure 22](#).
2. Certain sources will produce a cleaner comparator output waveform if a 100 pF to 1000 pF capacitor C2 is connected directly across the input pins.
3. When the signal source is applied through a resistive network, R_S , it is usually advantageous to choose an R_S' of substantially the same value, both for DC and for dynamic (AC) considerations. Carbon, tin-oxide, and metal-film resistors have all been used successfully in comparator input circuitry. Inductive wire wound resistors are not suitable.
4. When comparator circuits use input resistors (e.g. summing resistors), their value and placement are particularly important. In all cases the body of the resistor should be close to the device or socket. In other words there should be very little lead length or printed-circuit foil run between comparator and resistor to radiate or pick up signals. The same applies to capacitors, pots, etc. For example, if $R_S=10 \text{ k}\Omega$, as little as 5 inches of lead between the resistors and the input pins can result in oscillations that are very hard to damp. Twisting these input leads tightly is the only (second best) alternative to placing resistors close to the comparator.
5. Since feedback to almost any pin of a comparator can result in oscillation, the printed-circuit layout should be engineered thoughtfully. Preferably there should be a ground plane under the LM111 circuitry, for example, one side of a double-layer circuit card. Ground foil (or, positive supply or negative supply foil) should extend between the output and the inputs, to act as a guard. The foil connections for the inputs should be as small and compact as possible, and should be essentially surrounded by ground foil on all sides, to guard against capacitive coupling from any high-level signals (such as the output). If pins 5 and 6 are not used, they should be shorted together. If they are connected to a trim-pot, the trim-pot should be located, at most, a few inches away from the LM111, and the 0.01 μF capacitor should be installed. If this capacitor cannot be used, a shielding printed-circuit foil may be advisable between pins 6 and 7. The power supply bypass capacitors should be located within a couple inches of the LM111. (Some other comparators require the power-supply bypass to be located immediately adjacent to the comparator.)
6. It is a standard procedure to use hysteresis (positive feedback) around a comparator, to prevent oscillation, and to avoid excessive noise on the output because the comparator is a good amplifier for its own noise. In the circuit of [Figure 23](#), the feedback from the output to the positive input will cause about 3 mV of hysteresis. However, if R_S is larger than 100 Ω , such as 50 $\text{k}\Omega$, it would not be reasonable to simply increase the value of the positive feedback resistor above 510 $\text{k}\Omega$. The circuit of [Figure 24](#) could be used, but it is rather awkward. See the notes in paragraph 7 below.
7. When both inputs of the LM111 are connected to active signals, or if a high-impedance signal is driving the positive input of the LM111 so that positive feedback would be disruptive, the circuit of [Figure 22](#) is ideal. The positive feedback is to pin 5 (one of the offset adjustment pins). It is sufficient to cause 1 to 2 mV hysteresis and sharp transitions with input triangle waves from a few Hz to hundreds of kHz. The positive-feedback signal across the 82 Ω resistor swings 240 mV below the positive supply. This signal is centered around the nominal voltage at pin 5, so this feedback does not add to the V_{OS} of the comparator. As much as 8 mV of V_{OS} can be trimmed out, using the 5 $\text{k}\Omega$ pot and 3 $\text{k}\Omega$ resistor as shown.
8. These application notes apply specifically to the LM111 and are applicable to all high-speed comparators in general, (with the exception that not all comparators have trim pins).



Pin connections shown are for LM111H in the LMC0008C package

Figure 22. Improved Positive Feedback



Pin connections shown are for LM111H in the LMC0008C package

Figure 23. Conventional Positive Feedback

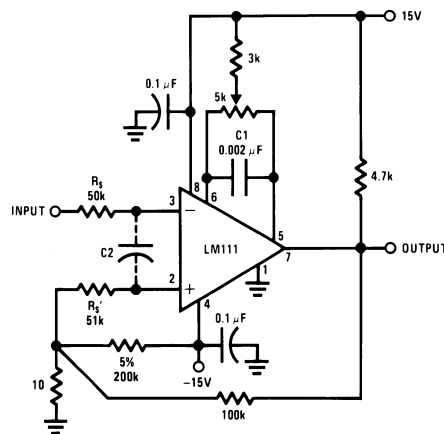


Figure 24. Positive Feedback with High Source Resistance

TYPICAL APPLICATIONS

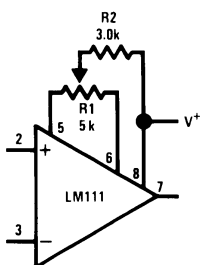
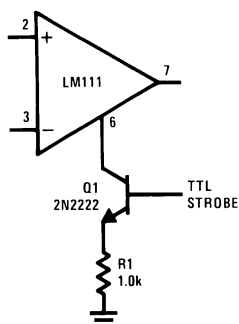
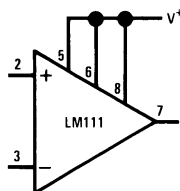


Figure 25. Offset Balancing



Note: Do Not Ground Strobe Pin. Output is turned off when current is pulled from Strobe Pin.

Figure 26. Strobing



Increases typical common mode slew from 7.0V/μs to 18V/μs.

Figure 27. Increasing Input Stage Current

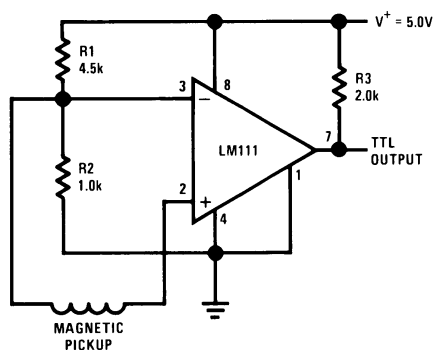


Figure 28. Detector for Magnetic Transducer

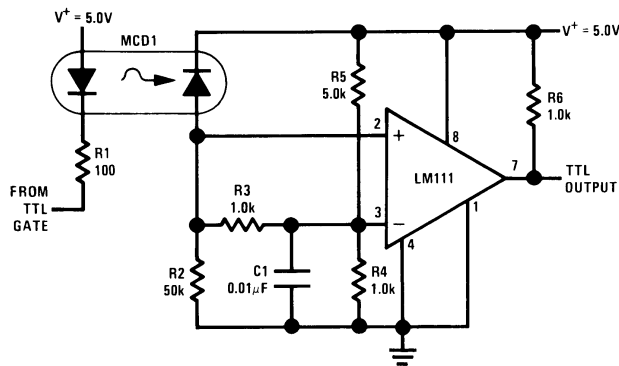
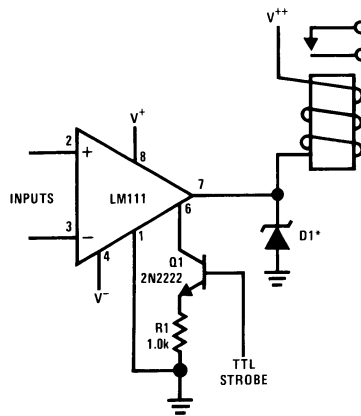
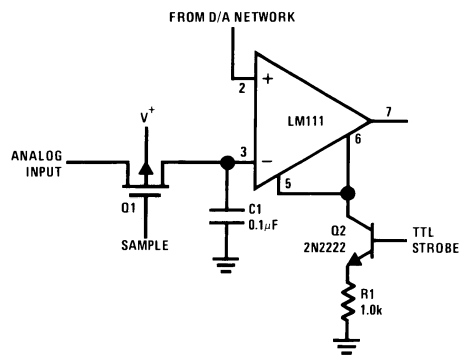


Figure 29. Digital Transmission Isolator



*Absorbs inductive kickback of relay and protects IC from severe voltage transients on V++ line.
Note: Do Not Ground Strobe Pin.

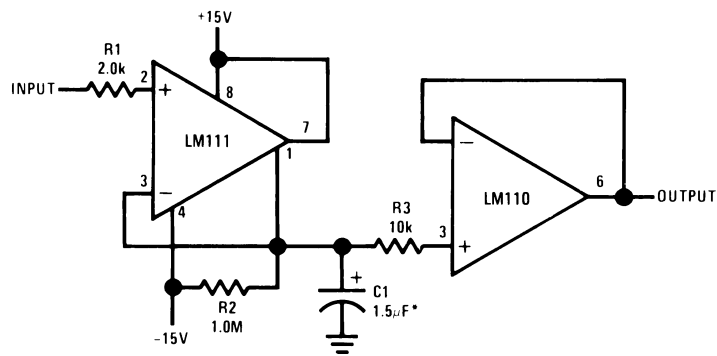
Figure 30. Relay Driver with Strobe



Note: Do Not Ground Strobe Pin.

- (1) Typical input current is 50 pA with inputs strobed off.
- (2) Pin connections shown on schematic diagram and typical applications are for LMC0008C package.

Figure 31. Strobing off Both Input and Output Stages



*Solid tantalum

Figure 32. Positive Peak Detector

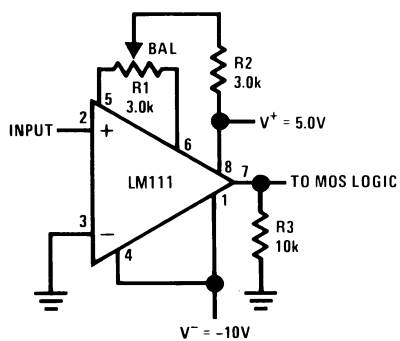


Figure 33. Zero Crossing Detector Driving MOS Logic

TYPICAL APPLICATIONS FOR METAL CYLINDER PACKAGE

(Pin numbers refer to LMC0008C package)

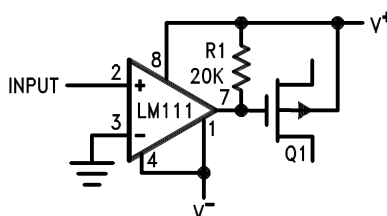
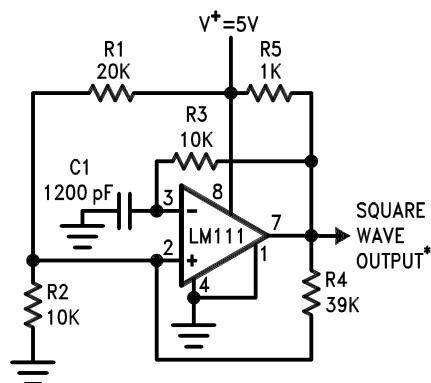
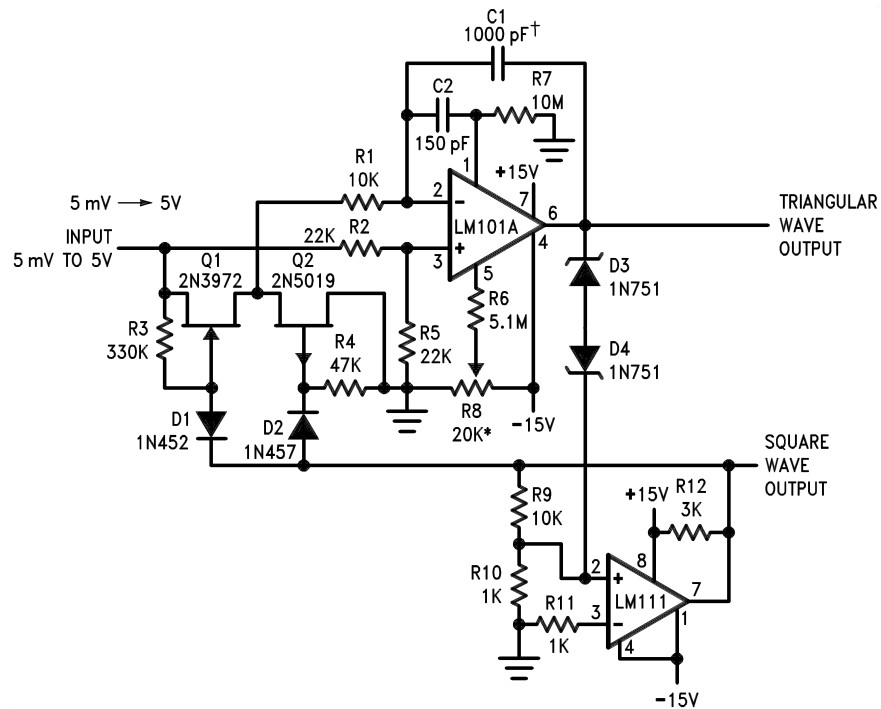


Figure 34. Zero Crossing Detector Driving MOS Switch



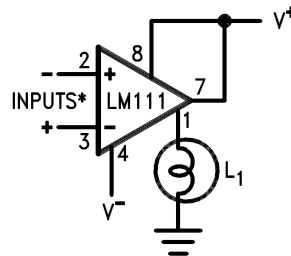
*TTL or DTL fanout of two

Figure 35. 100 kHz Free Running Multivibrator



*Adjust for symmetrical square wave time when $V_{IN} = 5 \text{ mV}$
 †Minimum capacitance 20 pF Maximum frequency 50 kHz

Figure 36. 10 Hz to 10 kHz Voltage Controlled Oscillator



*Input polarity is reversed when using pin 1 as output.

Figure 37. Driving Ground-Referred Load

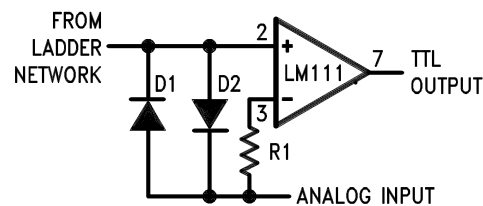
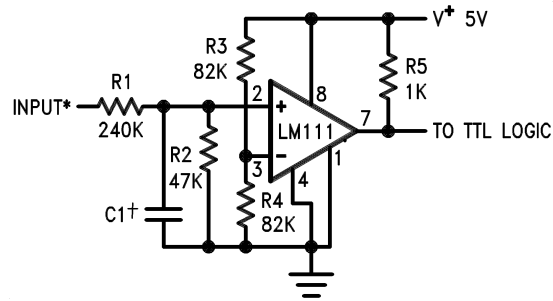


Figure 38. Using Clamp Diodes to Improve Response



*Values shown are for a 0 to 30V logic swing and a 15V threshold.

†May be added to control speed and reduce susceptibility to noise spikes.

Figure 39. TTL Interface with High Level Logic

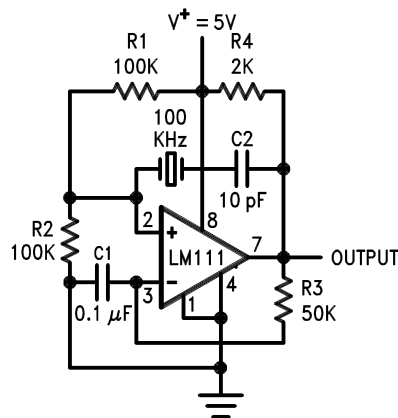


Figure 40. Crystal Oscillator

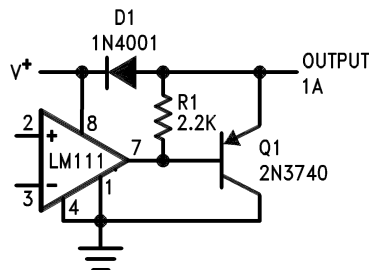
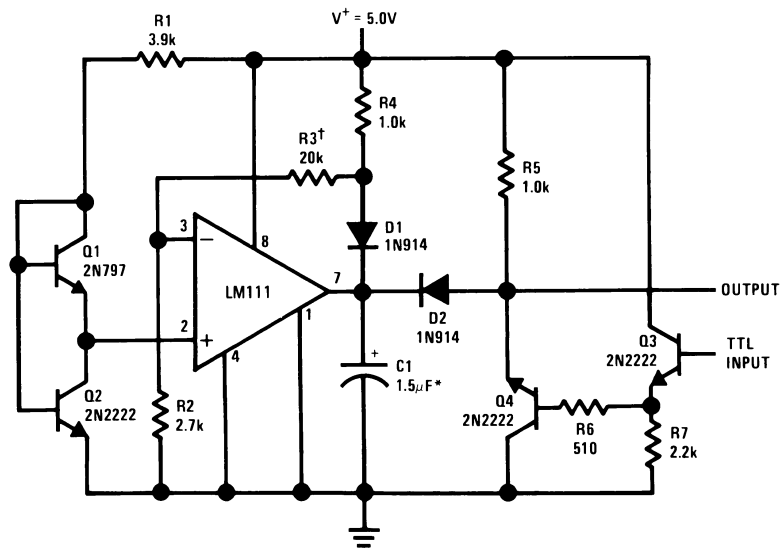
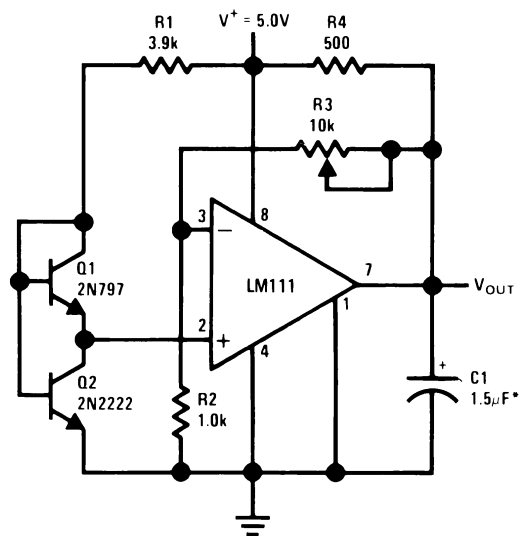


Figure 41. Comparator and Solenoid Driver



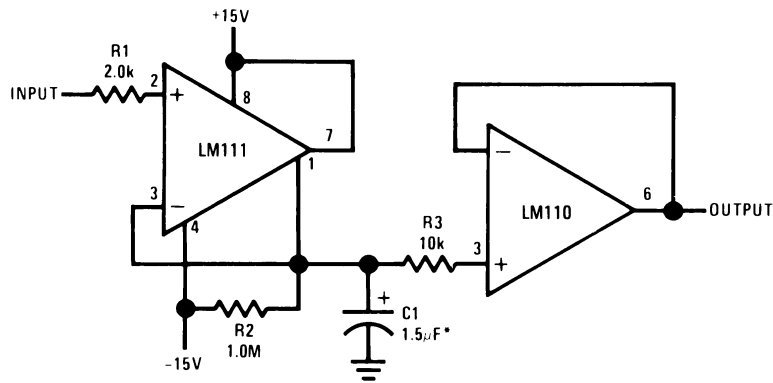
*Solid tantalum
†Adjust to set clamp level

Figure 42. Precision Squarer



*Solid tantalum

Figure 43. Low Voltage Adjustable Reference Supply



*Solid tantalum

Figure 44. Positive Peak Detector

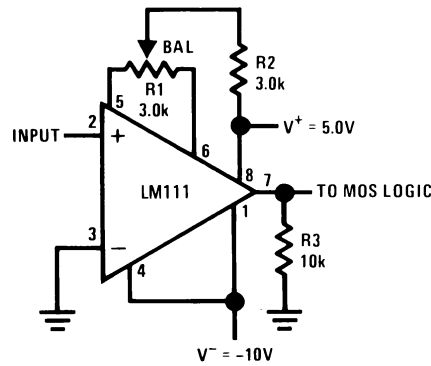
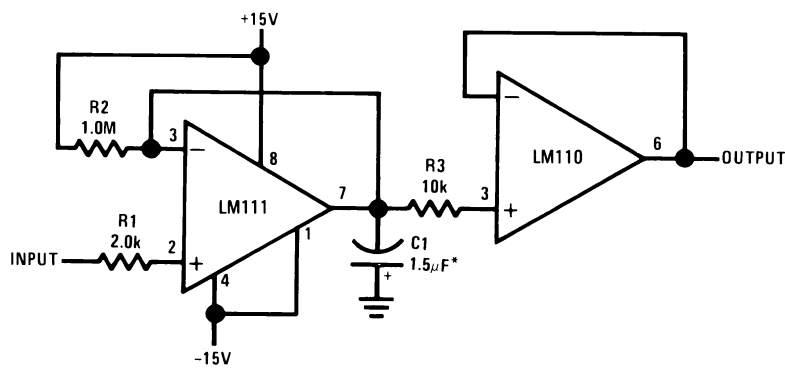
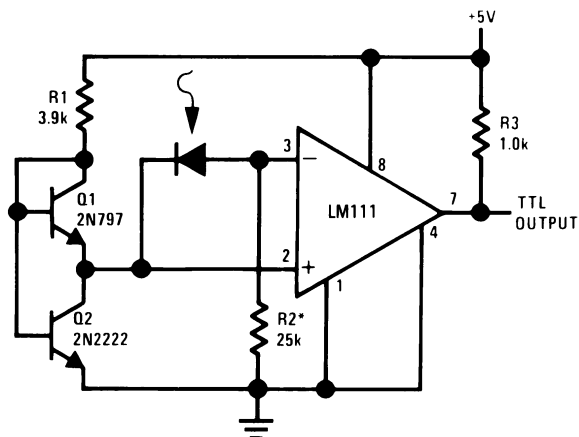


Figure 45. Zero Crossing Detector Driving MOS Logic



*Solid tantalum

Figure 46. Negative Peak Detector



*R2 sets the comparison level. At comparison, the photodiode has less than 5 mV across it, decreasing leakages by an order of magnitude.

Figure 47. Precision Photodiode Comparator

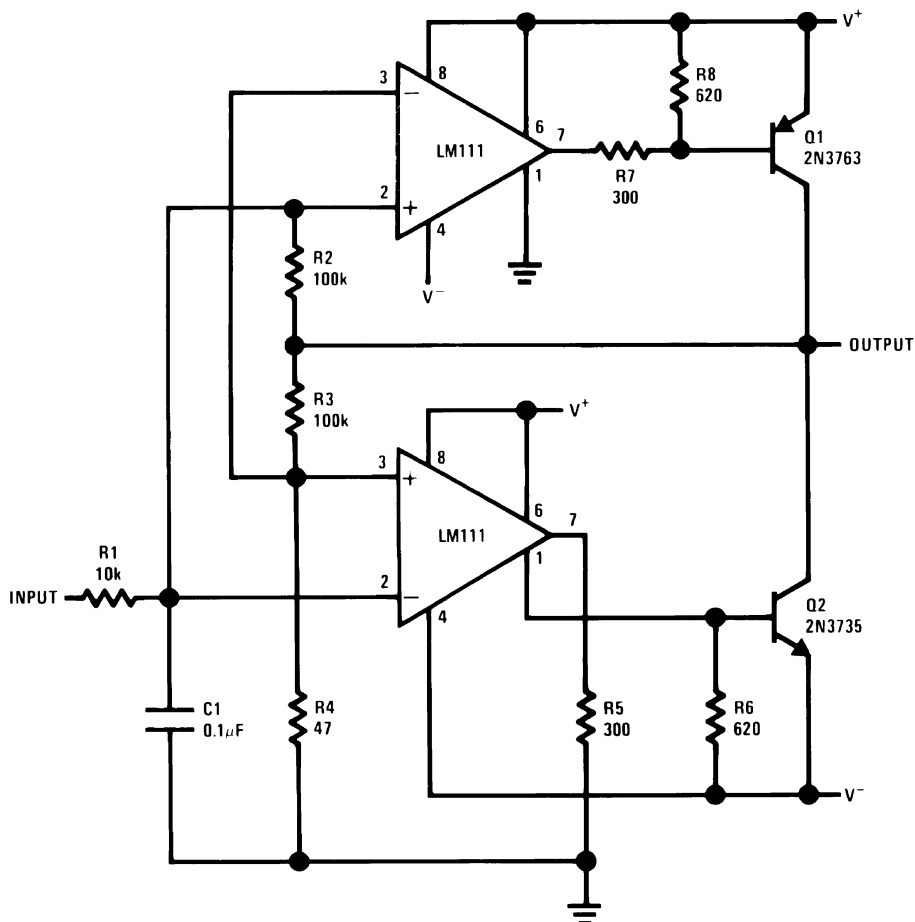


Figure 48. Switching Power Amplifier

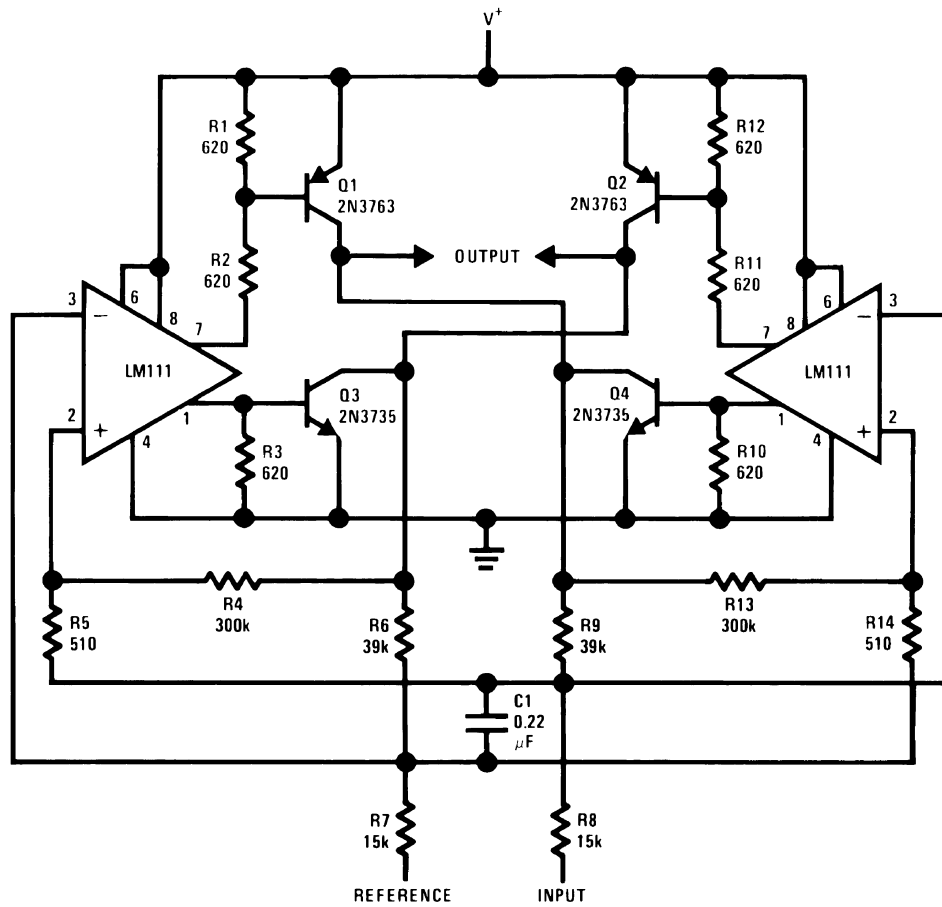


Figure 49. Switching Power Amplifier



Table 2. Revision History

Released	Revision	Section	Originator	Changes
10/11/05	A	New Release, Corporate format	L. Lytle	3 MDS data sheets converted into one Corp. data sheet format. MNLM111-X Rev 0A0, MDLM111-X Rev. 0B0, and MRLM111-X-RH Rev 0E1. The drift table was eliminated from the 883 section since it did not apply; Note #3 was removed from RH & QML datasheets with SG verification that it no longer applied. Added NSID's for 50k Rad and Post Radiation Table. MDS data sheets will be archived.
12/14/05	B	Ordering Information Table	R. Malone	Removed NSID reference LM111J-8PQMLV, 5962P0052401VPA 30k rd(Si). Reason: NSID on LTB, Inventory exhausted. Added following NSID's: LM111HPQMLV, LM111WPQMLV and LM111WGPQMLV. Reason: Still have Inventory. LM111QML, Revision A will be archived.
06/26/08	C	Features, Ordering Information Table, Electrical section Notes.	Larry McGee	Added Radiation reference, ELDRS NSID's and Note 14 and 15, Low Dose Electrical Table. Deleted 30k rd(Si) NSID's: LM111HPQMLV, LM111WPQMLV and LM111WGPQMLV. Reason: EOL 9/06/05. Revision B will be archived.
03/26/2013	C	All Sections		Changed layout of National Data Sheet to TI format

PACKAGING INFORMATION

Orderable Device	Status (1)	Package Type	Package Drawing	Pins	Package Qty	Eco Plan (2)	Lead/Ball Finish	MSL Peak Temp (3)	Op Temp (°C)	Top-Side Markings (4)	Samples
5962L0052401VGA	ACTIVE	TO-99	LMC	8	20	TBD	Call TI	Call TI	-55 to 125	LM111HLQMLV 5962L0052401VGA Q ACO 5962L0052401VGA Q >T	Samples
5962L0052401VHA	ACTIVE	CFP	NAD	10	19	TBD	Call TI	Call TI	-55 to 125	LM111W LQMLV Q 5962L00524 01VHA ACO 01VHA >T	Samples
5962L0052401VPA	ACTIVE	CDIP	NAB	8	40	TBD	Call TI	Call TI	-55 to 125	LM111J-8LQV 5962L00524 01VPA Q ACO 01VPA Q >T	Samples
5962L0052401VZA	ACTIVE	CFP	NAC	10	54	TBD	Call TI	Call TI	-55 to 125	LM111W GLQMLV Q 5962L00524 01VZA ACO 01VZA >T	Samples
5962R0052402VGA	ACTIVE	TO-99	LMC	8	20	TBD	Call TI	Call TI	-55 to 125	LM111HRLQV 5962R0052402VGA Q ACO 5962R0052402VGA Q >T	Samples
5962R0052402VHA	ACTIVE	CFP	NAD	10	19	TBD	Call TI	Call TI	-55 to 125	LM111W RLQMLV Q 5962R00524 02VHA ACO 02VHA >T	Samples
5962R0052402VPA	ACTIVE	CDIP	NAB	8	40	TBD	Call TI	Call TI	-55 to 125	LM111J-8RLQV 5962R00524 02VPA Q ACO 02VPA Q >T	Samples
5962R0052402VZA	ACTIVE	CFP	NAC	10	54	TBD	Call TI	Call TI	-55 to 125	LM111W GRLQMLV Q 5962R00524 02VZA ACO 02VZA >T	Samples

Orderable Device	Status (1)	Package Type	Package Drawing	Pins	Package Qty	Eco Plan (2)	Lead/Ball Finish	MSL Peak Temp (3)	Op Temp (°C)	Top-Side Markings (4)	Samples
LM111H/883	ACTIVE	TO-99	LMC	8	20	TBD	Call TI	Call TI	-55 to 125	LM111H/883 Q ACO LM111H/883 Q >T	Samples
LM111HLQMLV	ACTIVE	TO-99	LMC	8	20	TBD	Call TI	Call TI	-55 to 125	LM111HLQMLV 5962L0052401VGA Q ACO 5962L0052401VGA Q >T	Samples
LM111HRLQMLV	ACTIVE	TO-99	LMC	8	20	TBD	Call TI	Call TI	-55 to 125	LM111HRLQV 5962R0052402VGA Q ACO 5962R0052402VGA Q >T	Samples
LM111J-8/883	ACTIVE	CDIP	NAB	8	40	TBD	Call TI	Call TI	-55 to 125	LM111J-8 /883 Q ACO /883 Q >T	Samples
LM111J-8LQMLV	ACTIVE	CDIP	NAB	8	40	TBD	Call TI	Call TI	-55 to 125	LM111J-8LQV 5962L00524 01VPA Q ACO 01VPA Q >T	Samples
LM111J-8RLQMLV	ACTIVE	CDIP	NAB	8	40	TBD	Call TI	Call TI	-55 to 125	LM111J-8RLQV 5962R00524 02VPA Q ACO 02VPA Q >T	Samples
LM111J/883	ACTIVE	CDIP	J	14	25	TBD	Call TI	Call TI	-55 to 125	LM111J/883 Q	Samples
LM111WG/883	ACTIVE	CFP	NAC	10	54	TBD	Call TI	Call TI	-55 to 125	LM111WG /883 Q ACO /883 Q >T	Samples
LM111WGLQMLV	ACTIVE	CFP	NAC	10	54	TBD	Call TI	Call TI	-55 to 125	LM111W GLQMLV Q 5962L00524 01VZA ACO 01VZA >T	Samples
LM111WGRLQMLV	ACTIVE	CFP	NAC	10	54	TBD	Call TI	Call TI	-55 to 125	LM111W GRLQMLV Q 5962R00524 02VZA ACO 02VZA >T	Samples

Orderable Device	Status (1)	Package Type	Package Drawing	Pins	Package Qty	Eco Plan (2)	Lead/Ball Finish	MSL Peak Temp (3)	Op Temp (°C)	Top-Side Markings (4)	Samples
LM111WLQMLV	ACTIVE	CFP	NAD	10	19	TBD	Call TI	Call TI	-55 to 125	LM111W LQMLV Q 5962L00524 01VHA ACO 01VHA >T	
LM111WRLQMLV	ACTIVE	CFP	NAD	10	19	TBD	Call TI	Call TI	-55 to 125	LM111W RLQMLV Q 5962R00524 02VHA ACO 02VHA >T	

(1) The marketing status values are defined as follows:

ACTIVE: Product device recommended for new designs.

LIFEBUY: TI has announced that the device will be discontinued, and a lifetime-buy period is in effect.

NRND: Not recommended for new designs. Device is in production to support existing customers, but TI does not recommend using this part in a new design.

PREVIEW: Device has been announced but is not in production. Samples may or may not be available.

OBSELETE: TI has discontinued the production of the device.

(2) Eco Plan - The planned eco-friendly classification: Pb-Free (RoHS), Pb-Free (RoHS Exempt), or Green (RoHS & no Sb/Br) - please check <http://www.ti.com/productcontent> for the latest availability information and additional product content details.

TBD: The Pb-Free/Green conversion plan has not been defined.

Pb-Free (RoHS): TI's terms "Lead-Free" or "Pb-Free" mean semiconductor products that are compatible with the current RoHS requirements for all 6 substances, including the requirement that lead not exceed 0.1% by weight in homogeneous materials. Where designed to be soldered at high temperatures, TI Pb-Free products are suitable for use in specified lead-free processes.

Pb-Free (RoHS Exempt): This component has a RoHS exemption for either 1) lead-based flip-chip solder bumps used between the die and package, or 2) lead-based die adhesive used between the die and leadframe. The component is otherwise considered Pb-Free (RoHS compatible) as defined above.

Green (RoHS & no Sb/Br): TI defines "Green" to mean Pb-Free (RoHS compatible), and free of Bromine (Br) and Antimony (Sb) based flame retardants (Br or Sb do not exceed 0.1% by weight in homogeneous material)

(3) MSL, Peak Temp. -- The Moisture Sensitivity Level rating according to the JEDEC industry standard classifications, and peak solder temperature.

(4) Multiple Top-Side Markings will be inside parentheses. Only one Top-Side Marking contained in parentheses and separated by a "-" will appear on a device. If a line is indented then it is a continuation of the previous line and the two combined represent the entire Top-Side Marking for that device.

Important Information and Disclaimer: The information provided on this page represents TI's knowledge and belief as of the date that it is provided. TI bases its knowledge and belief on information provided by third parties, and makes no representation or warranty as to the accuracy of such information. Efforts are underway to better integrate information from third parties. TI has taken and continues to take reasonable steps to provide representative and accurate information but may not have conducted destructive testing or chemical analysis on incoming materials and chemicals. TI and TI suppliers consider certain information to be proprietary, and thus CAS numbers and other limited information may not be available for release.

In no event shall TI's liability arising out of such information exceed the total purchase price of the TI part(s) at issue in this document sold by TI to Customer on an annual basis.

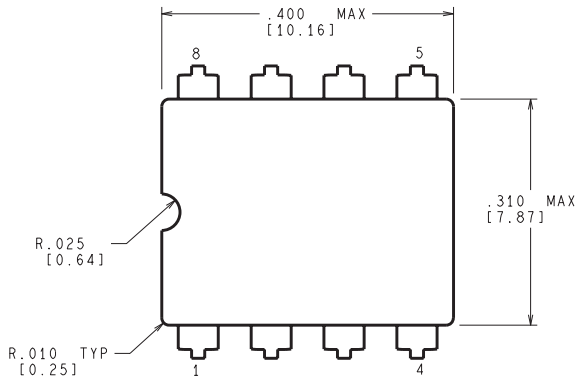
OTHER QUALIFIED VERSIONS OF LM111QML, LM111QML-SP :

- Military: [LM111QML](#)
- Space: [LM111QML-SP](#)

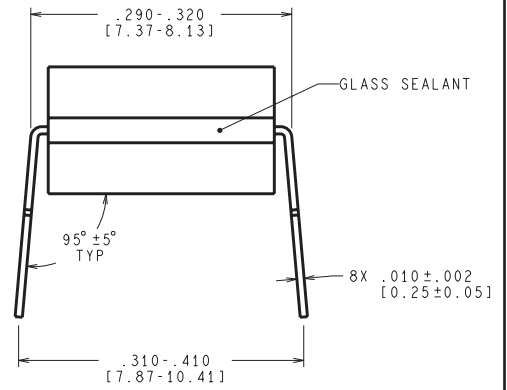
NOTE: Qualified Version Definitions:

- Military - QML certified for Military and Defense Applications
- Space - Radiation tolerant, ceramic packaging and qualified for use in Space-based application

NAB0008A



CONTROLLING DIMENSION IS INCH
VALUES IN [] ARE MILLIMETERS

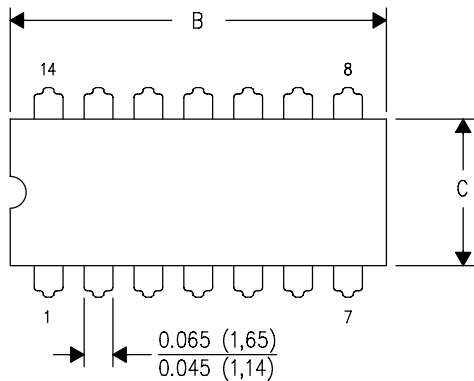


J08A (Rev M)

J (R-GDIP-T**)

14 LEADS SHOWN

CERAMIC DUAL IN-LINE PACKAGE



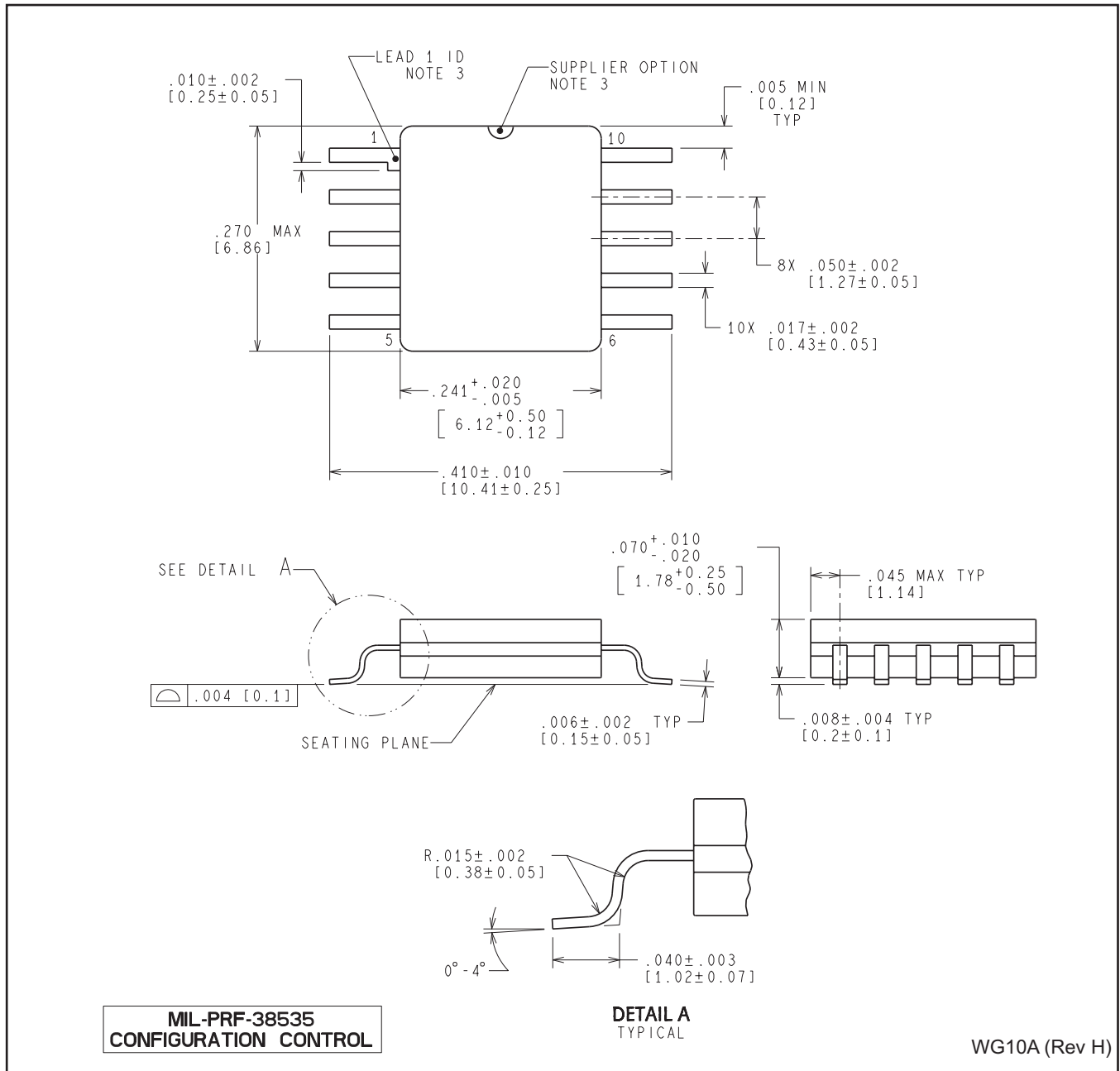
DIM \ PINS **	14	16	18	20
A	0.300 (7,62) BSC	0.300 (7,62) BSC	0.300 (7,62) BSC	0.300 (7,62) BSC
B MAX	0.785 (19,94)	.840 (21,34)	0.960 (24,38)	1.060 (26,92)
B MIN	—	—	—	—
C MAX	0.300 (7,62)	0.300 (7,62)	0.310 (7,87)	0.300 (7,62)
C MIN	0.245 (6,22)	0.245 (6,22)	0.220 (5,59)	0.245 (6,22)



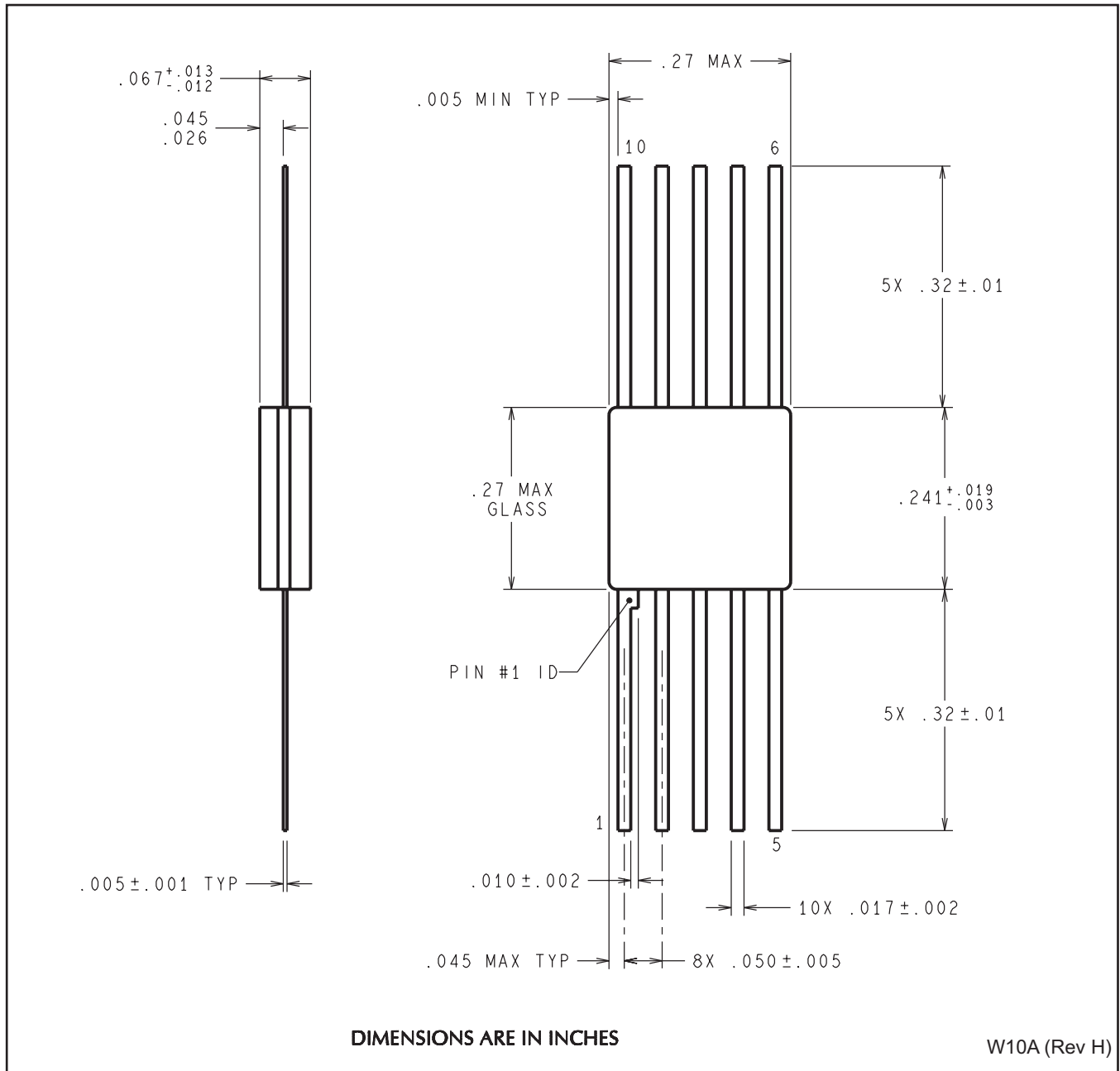
4040083/F 03/03

- NOTES:
- All linear dimensions are in inches (millimeters).
 - This drawing is subject to change without notice.
 - This package is hermetically sealed with a ceramic lid using glass frit.
 - Index point is provided on cap for terminal identification only on press ceramic glass frit seal only.
 - Falls within MIL STD 1835 GDIP1-T14, GDIP1-T16, GDIP1-T18 and GDIP1-T20.

NAC0010A

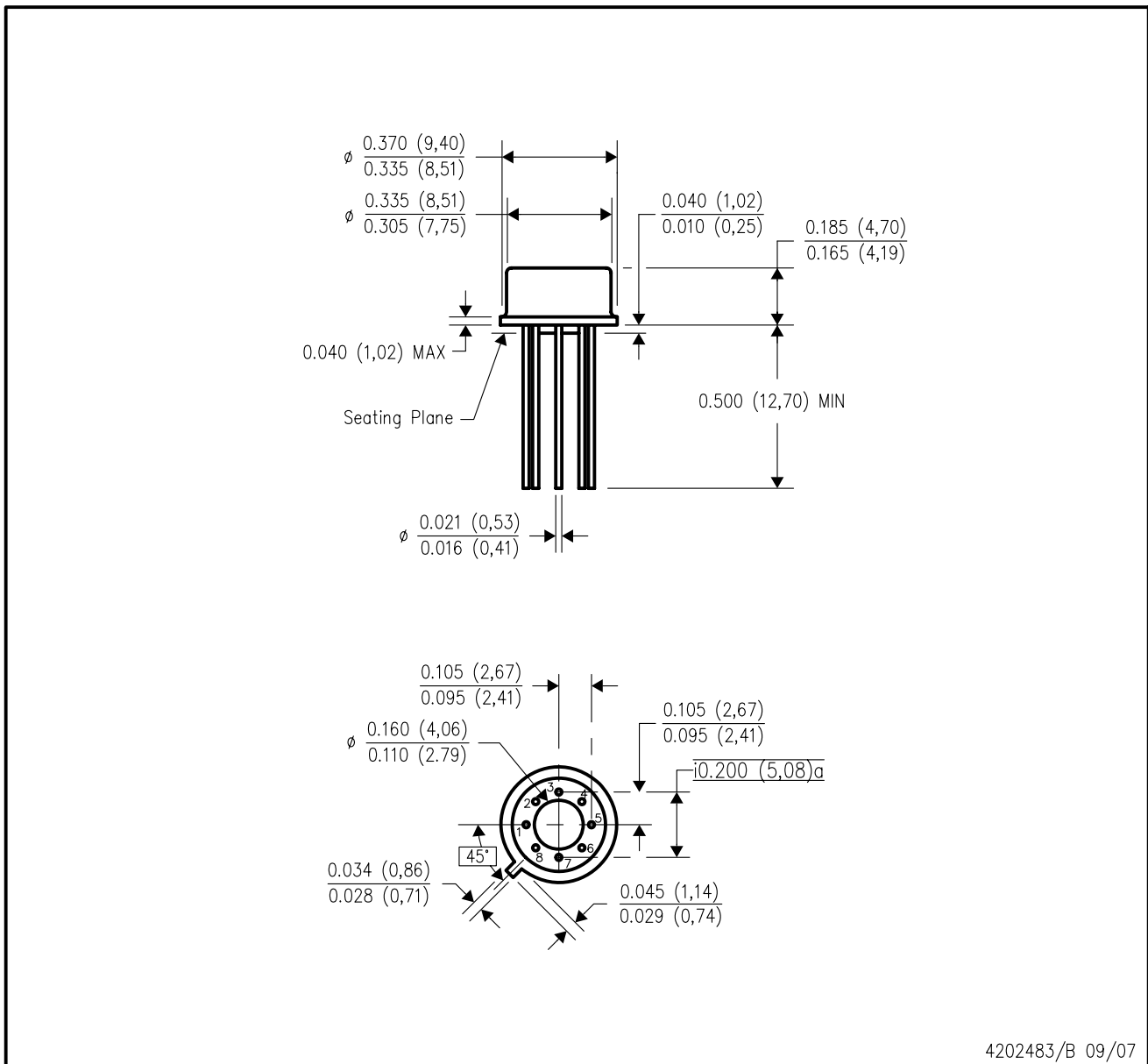


NAD0010A



LMC (O-MBCY-W8)

METAL CYLINDRICAL PACKAGE



- NOTES:
- A. All linear dimensions are in inches (millimeters).
 - B. This drawing is subject to change without notice.
 - C. Leads in true position within 0.010 (0,25) R @ MMC at seating plane.
 - D. Pin numbers shown for reference only. Numbers may not be marked on package.
 - E. Falls within JEDEC MO-002/TO-99.

IMPORTANT NOTICE

Texas Instruments Incorporated and its subsidiaries (TI) reserve the right to make corrections, enhancements, improvements and other changes to its semiconductor products and services per JESD46, latest issue, and to discontinue any product or service per JESD48, latest issue. Buyers should obtain the latest relevant information before placing orders and should verify that such information is current and complete. All semiconductor products (also referred to herein as "components") are sold subject to TI's terms and conditions of sale supplied at the time of order acknowledgment.

TI warrants performance of its components to the specifications applicable at the time of sale, in accordance with the warranty in TI's terms and conditions of sale of semiconductor products. Testing and other quality control techniques are used to the extent TI deems necessary to support this warranty. Except where mandated by applicable law, testing of all parameters of each component is not necessarily performed.

TI assumes no liability for applications assistance or the design of Buyers' products. Buyers are responsible for their products and applications using TI components. To minimize the risks associated with Buyers' products and applications, Buyers should provide adequate design and operating safeguards.

TI does not warrant or represent that any license, either express or implied, is granted under any patent right, copyright, mask work right, or other intellectual property right relating to any combination, machine, or process in which TI components or services are used. Information published by TI regarding third-party products or services does not constitute a license to use such products or services or a warranty or endorsement thereof. Use of such information may require a license from a third party under the patents or other intellectual property of the third party, or a license from TI under the patents or other intellectual property of TI.

Reproduction of significant portions of TI information in TI data books or data sheets is permissible only if reproduction is without alteration and is accompanied by all associated warranties, conditions, limitations, and notices. TI is not responsible or liable for such altered documentation. Information of third parties may be subject to additional restrictions.

Resale of TI components or services with statements different from or beyond the parameters stated by TI for that component or service voids all express and any implied warranties for the associated TI component or service and is an unfair and deceptive business practice. TI is not responsible or liable for any such statements.

Buyer acknowledges and agrees that it is solely responsible for compliance with all legal, regulatory and safety-related requirements concerning its products, and any use of TI components in its applications, notwithstanding any applications-related information or support that may be provided by TI. Buyer represents and agrees that it has all the necessary expertise to create and implement safeguards which anticipate dangerous consequences of failures, monitor failures and their consequences, lessen the likelihood of failures that might cause harm and take appropriate remedial actions. Buyer will fully indemnify TI and its representatives against any damages arising out of the use of any TI components in safety-critical applications.

In some cases, TI components may be promoted specifically to facilitate safety-related applications. With such components, TI's goal is to help enable customers to design and create their own end-product solutions that meet applicable functional safety standards and requirements. Nonetheless, such components are subject to these terms.

No TI components are authorized for use in FDA Class III (or similar life-critical medical equipment) unless authorized officers of the parties have executed a special agreement specifically governing such use.

Only those TI components which TI has specifically designated as military grade or "enhanced plastic" are designed and intended for use in military/aerospace applications or environments. Buyer acknowledges and agrees that any military or aerospace use of TI components which have **not** been so designated is solely at the Buyer's risk, and that Buyer is solely responsible for compliance with all legal and regulatory requirements in connection with such use.

TI has specifically designated certain components as meeting ISO/TS16949 requirements, mainly for automotive use. In any case of use of non-designated products, TI will not be responsible for any failure to meet ISO/TS16949.

Products

Audio	www.ti.com/audio
Amplifiers	amplifier.ti.com
Data Converters	dataconverter.ti.com
DLP® Products	www.dlp.com
DSP	dsp.ti.com
Clocks and Timers	www.ti.com/clocks
Interface	interface.ti.com
Logic	logic.ti.com
Power Mgmt	power.ti.com
Microcontrollers	microcontroller.ti.com
RFID	www.ti-rfid.com
OMAP Applications Processors	www.ti.com/omap
Wireless Connectivity	www.ti.com/wirelessconnectivity

Applications

Automotive and Transportation	www.ti.com/automotive
Communications and Telecom	www.ti.com/communications
Computers and Peripherals	www.ti.com/computers
Consumer Electronics	www.ti.com/consumer-apps
Energy and Lighting	www.ti.com/energy
Industrial	www.ti.com/industrial
Medical	www.ti.com/medical
Security	www.ti.com/security
Space, Avionics and Defense	www.ti.com/space-avionics-defense
Video and Imaging	www.ti.com/video

TI E2E Community

e2e.ti.com