

LM101AQL Operational Amplifiers

Check for Samples: [LM101AQL](#)

FEATURES

- Available with Radiation Guarantee
- Offset Voltage 3 mV Maximum Over Temperature
- Input Current 100 nA Maximum Over Temperature
- Offset Current 20 nA Maximum Over Temperature
- Ensured Drift Characteristics
- Offsets Specified Over Entire Common Mode and Supply Voltage Ranges
- Slew Rate of 10 V/ μ S as a Summing Amplifier

DESCRIPTION

The LM101A is a general purpose operational amplifier which features improved performance over industry standards such as the LM709. Advanced processing techniques make possible an order of magnitude reduction in input currents, and a redesign of the biasing circuitry reduces the temperature drift of input current. Improved specifications include:

- Offset voltage 3 mV maximum over temperature
- Input current 100 nA maximum over temperature
- Offset current 20 nA maximum over temperature
- Specified drift characteristics
- Offsets ensured over entire common mode and supply voltage ranges
- Slew rate of 10V/ μ s as a summing amplifier
 - This amplifier offers many features which make its application nearly foolproof: overload protection on the input and output, no latch-up when the common mode range is exceeded, and freedom from oscillations and compensation with a single 30 pF capacitor. It has advantages over internally compensated amplifiers in that the frequency compensation can be tailored to the particular application. For example, in low frequency circuits it can be overcompensated for increased stability margin. Or the compensation can be optimized to give more than a factor of ten improvement in high frequency performance for most applications.
 - In addition, the device provides better accuracy and lower noise in high impedance circuitry. The low input currents also make it particularly well suited for long interval integrators or timers, sample and hold circuits and low frequency waveform generators. Further, replacing circuits where matched transistor pairs buffer the inputs of conventional IC op amps, it can give lower offset voltage and a drift at a lower cost.



Please be aware that an important notice concerning availability, standard warranty, and use in critical applications of Texas Instruments semiconductor products and disclaimers thereto appears at the end of this data sheet.

All trademarks are the property of their respective owners.



These devices have limited built-in ESD protection. The leads should be shorted together or the device placed in conductive foam during storage or handling to prevent electrostatic damage to the MOS gates.

Schematic

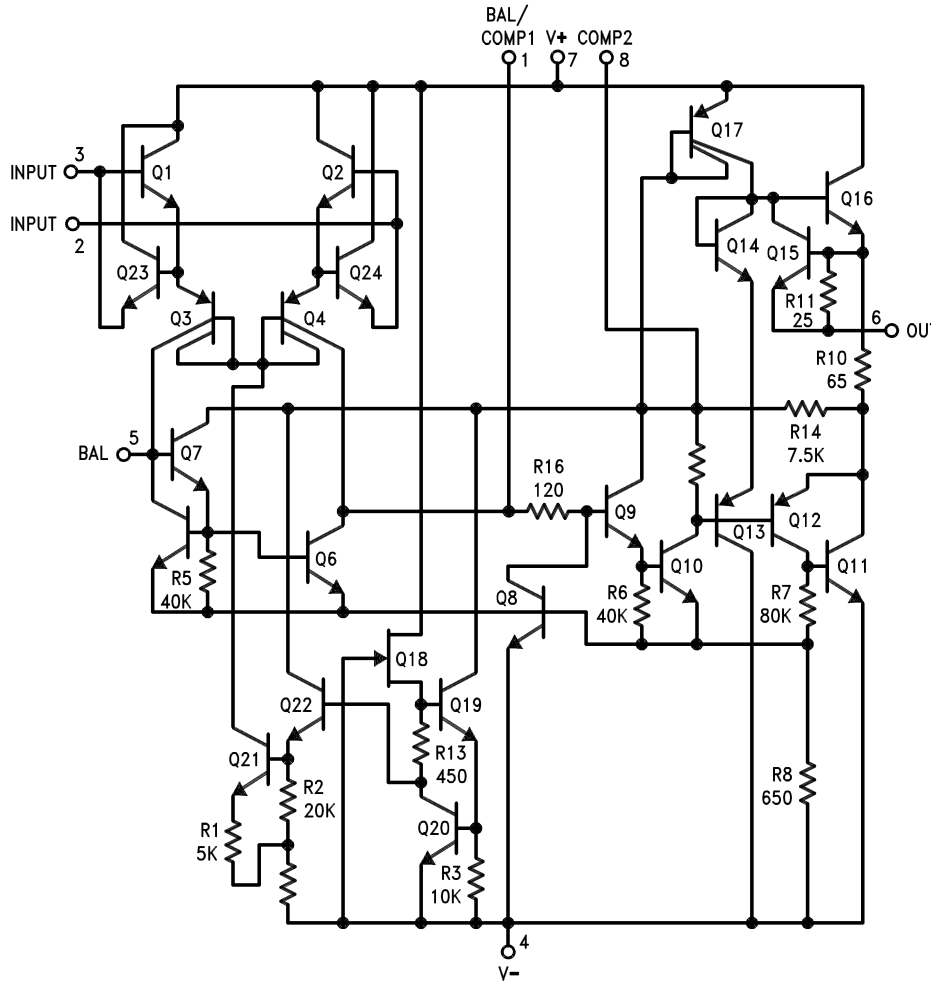

Pin connections shown are for 8-pin packages.

Connection Diagrams

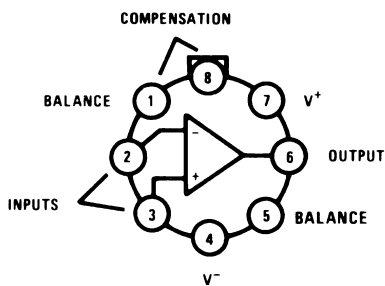

Figure 1. TO Package (Top View)
See Package Number LMC0008C

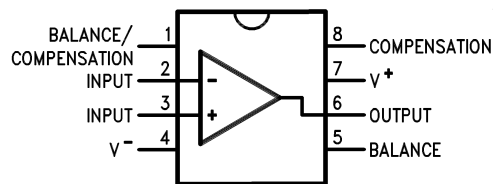

Figure 2. CDIP Package (Top View)
See Package Number NAB0008A

Note: Pin 4 connected to case.

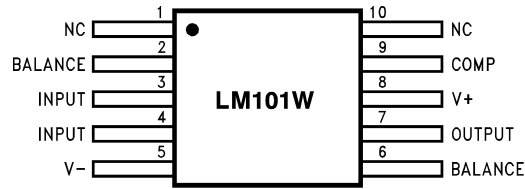
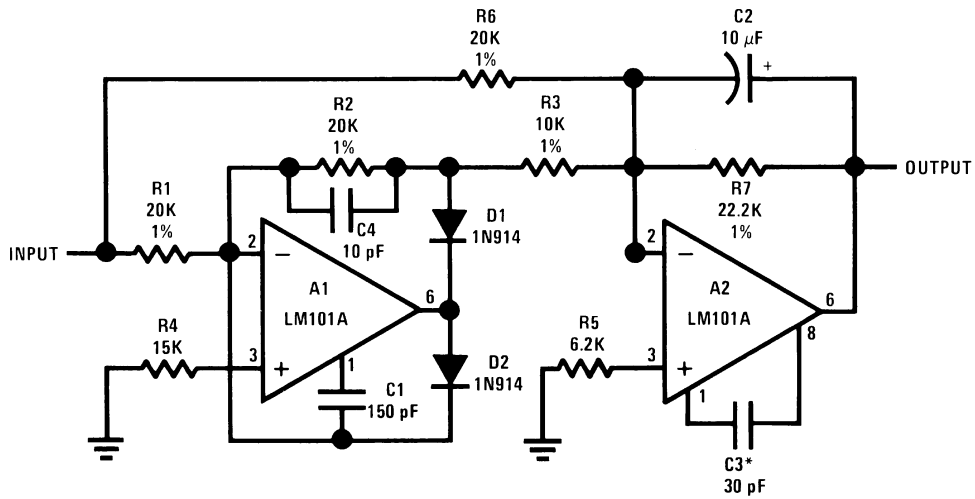

Figure 3. CLGA Package (Top View)
See Package Number NAD0010A

Fast AC/DC Converter



Note: Feedforward compensation can be used to make a fast full wave rectifier without a filter.

Absolute Maximum Ratings⁽¹⁾

Supply Voltage		±22V		
Differential Input Voltage		±30V		
Input Voltage ⁽²⁾		±15V		
Output Short Circuit Duration		Continuous		
Operating Ambient Temp. Range		-55°C ≤ T _A ≤ +125°C		
T _J Max		150°C		
Power Dissipation at T _A = 25°C ⁽³⁾		LMC-Package	(Still Air)	750 mW
			(500 LF / Min Air Flow)	1200 mW
		NAB-Package	(Still Air)	1000 mW
			(500 LF / Min Air Flow)	1500 mW
		NAD-Package	(Still Air)	500mW
			(500 LF / Min Air Flow)	800mW
Thermal Resistance	θ _{JA}	LMC-Package	(Still Air)	165°C/W
			(500 LF / Min Air Flow)	89°C/W
		NAB-Package	(Still Air)	128°C/W
			(500 LF / Min Air Flow)	75°C/W
	NAD-Package	(Still Air)	233°C/W	
		(500 LF / Min Air Flow)	155°C/W	
	θ _{JC} (Typical)	LMC-Package	39°C/W	
		NAB-Package	26°C/W	
NAD-Package		26°C/W		
Storage Temperature Range		-65°C ≤ T _A ≤ +150°C		
Lead Temperature (Soldering, 10 sec.)		300°C		
ESD Tolerance ⁽⁴⁾		3000V		

- (1) Absolute Maximum Ratings indicate limits beyond which damage to the device may occur. Operating ratings indicate conditions for which the device is intended to be functional, but do not ensure specific performance limits. For ensured specifications and test conditions, see the Electrical Characteristics. The specifications apply only for the test conditions listed. Some performance characteristics may degrade when the device is not operated under the listed test conditions.
- (2) For supply voltages less than ±15V, the absolute maximum input voltage is equal to the supply voltage.
- (3) The maximum power dissipation must be derated at elevated temperatures and is dictated by T_{Jmax} (maximum junction temperature), θ_{JA} (package junction to ambient thermal resistance), and T_A (ambient temperature). The maximum allowable power dissipation at any temperature is P_{Dmax} = (T_{Jmax} - T_A) / θ_{JA} or the number given in the Absolute Maximum Ratings, whichever is lower.
- (4) Human body model, 100 pF discharged through 1.5 kΩ.

Quality Conformance Inspection

Mil-Std-883, Method 5005 - Group A

Subgroup	Description	Temp (°C)
1	Static tests at	25
2	Static tests at	125
3	Static tests at	-55
4	Dynamic tests at	25
5	Dynamic tests at	125
6	Dynamic tests at	-55
7	Functional tests at	25
8A	Functional tests at	125
8B	Functional tests at	-55
9	Switching tests at	25
10	Switching tests at	125
11	Switching tests at	-55

LM101A 883 Electrical Characteristics DC Parameters

The following conditions apply to all parameters, unless otherwise specified

 $V_{CC} = \pm 20V$, $V_{CM} = 0V$

Symbol	Parameter	Conditions	Notes	Min	Max	Units	Sub-groups
V_{IO}	Input Offset Voltage	$V_{CM} = -15V$, $R_S = 50\Omega$		-2.0	2.0	mV	1
				-3.0	3.0	mV	2, 3
		$V_{CM} = 15V$, $R_S = 50\Omega$		-2.0	2.0	mV	1
				-3.0	3.0	mV	2, 3
		$R_S = 50\Omega$		-2.0	2.0	mV	1
				-3.0	3.0	mV	2, 3
$V_{CC} = \pm 5V$, $R_S = 50\Omega$		-2.0	2.0	mV	1		
		-3.0	3.0	mV	2, 3		
I_{IO}	Input Offset Current	$V_{CM} = -15V$		-10	10	nA	1
				-20	20	nA	2, 3
		$V_{CM} = 15V$		-10	10	nA	1
				-20	20	nA	2, 3
		$V_{CC} = \pm 5V$		-10	10	nA	1
				-20	20	nA	2, 3
$\pm I_B$	Input Bias Current	$V_{CM} = -15V$		1.0	75	nA	1
				1.0	100	nA	2, 3
		$V_{CM} = 15V$		1.0	75	nA	1
				1.0	100	nA	2, 3
		$V_{CC} = \pm 5V$		1.0	75	nA	1
				1.0	100	nA	2, 3
PSRR+	Power Supply Rejection Ratio	$+V_{CC} = +20V$ and $+5V$, $-V_{CC} = -20V$, $R_S = 50\Omega$		80		dB	1, 2, 3
PSRR-	Power Supply Rejection Ratio	$+V_{CC} = +20V$, $-V_{CC} = -20V$ and $-5V$, $R_S = 50\Omega$		80		dB	1, 2, 3
CMRR	Common Mode Rejection Ratio	$-15V \leq V_{CM} \leq 15V$, $R_S = 50\Omega$		80		dB	1, 2, 3
I_{CC}	Supply Current				3.0	mA	1
					2.5	mA	2
					3.5	mA	3
$+V_{IO}$ Adj	Input Offset Voltage Adjust			4.0		mV	1, 2, 3
$-V_{IO}$ Adj	Input Offset Voltage Adjust				-4.0	mV	1, 2, 3
$+I_{OS}$	Short Circuit Current			-45	-7.0	mA	1, 2, 3
$-I_{OS}$	Short Circuit Current			7.0	45	mA	1, 2, 3
V_I	Input Voltage Range	$V_{CC} = \pm 20V$	See ⁽¹⁾	-15	15	V	1, 2, 3
$+A_{VS}$	Large Signal Gain	$V_{CC} = \pm 15V$, $R_S = 0$, $R_L = 2K\Omega$, $V_O = 10V$		50		V/mV	4
				25		V/mV	5, 6
$-A_{VS}$	Large Signal Gain	$V_{CC} = \pm 15V$, $R_S = 0$, $R_L = 2K\Omega$, $V_O = -10V$		50		V/mV	4
				25		V/mV	5, 6
R_I	Input Resistance		See ⁽²⁾	1.5		M Ω	4
			see ⁽²⁾	0.5		M Ω	5, 6

(1) Parameter specified by the input conditions of several DC parameters

(2) Parameter specified by design, not tested.

LM101A 883 Electrical Characteristics DC Parameters (continued)

The following conditions apply to all parameters, unless otherwise specified

$$V_{CC} = \pm 20V, V_{CM} = 0V$$

Symbol	Parameter	Conditions	Notes	Min	Max	Units	Sub-groups
+V _{OP}	Output Voltage Swing	R _L = 10K Ω		16		V	4, 5, 6
		R _L = 2K Ω		15		V	4, 5, 6
		R _L = 10K Ω , V _{CC} = $\pm 15V$		12		V	4, 5, 6
		R _L = 2K Ω , V _{CC} = $\pm 15V$		10		V	4, 5, 6
-V _{OP}	Output Voltage Swing	R _L = 10K Ω			-16	V	4, 5, 6
		R _L = 2K Ω			-15	V	4, 5, 6
		R _L = 10K Ω , V _{CC} = $\pm 15V$			-12	V	4, 5, 6
		R _L = 2K Ω , V _{CC} = $\pm 15V$			-10	V	4, 5, 6

LM101A 883 Electrical Characteristics AC Parameters

The following conditions apply to all parameters, unless otherwise specified

$$V_{CC} = \pm 20V, R_L = 2K\Omega, A_V = 1$$

Symbol	Parameter	Conditions	Notes	Min	Max	Units	Sub-groups
+SR	Slew Rate	V _I = -5V to 5V			0.2	V/ μ S	7
-SR	Slew Rate	V _I = 5V to -5V			0.2	V/ μ S	7
G _{BW}	Gain Bandwidth	V _I = 50mV _{RMS} , f = 20KHz			0.25	MHz	7

LM101A QML and RH Electrical Characteristics⁽¹⁾ DC Parameters

The following conditions apply to all parameters, unless otherwise specified

$$V_{CC} = \pm 20V, V_{CM} = 0V, R_S = 50\Omega$$

Symbol	Parameter	Conditions	Notes	Min	Max	Units	Sub-groups
V _{IO}	Input Offset Voltage	+V _{CC} = 35V, -V _{CC} = -5V, V _{CM} = -15V		-2.0	+2.0	mV	1
				-3.0	+3.0	mV	2, 3
		+V _{CC} = 5V, -V _{CC} = -35V, V _{CM} = +15V		-2.0	+2.0	mV	1
				-3.0	+3.0	mV	2, 3
		V _{CM} = 0V		-2.0	+2.0	mV	1
				-3.0	+3.0	mV	2, 3
I _{IO}	Input Offset Current	+V _{CC} = 35V, -V _{CC} = -5V, V _{CM} = -15V, R _S = 100K Ω		-10	+10	nA	1, 2
				-20	+20	nA	3
		+V _{CC} = 5V, -V _{CC} = -35V, V _{CM} = +15V, R _S = 100K Ω		-10	+10	nA	1, 2
				-20	+20	nA	3
		V _{CM} = 0V, R _S = 100K Ω		-10	+10	nA	1, 2
				-20	+20	nA	3
+V _{CC} = 5V, -V _{CC} = -5V, V _{CM} = 0V, R _S = 100K Ω		-10	+10	nA	1, 2		
		-20	+20	nA	3		

(1) Pre and post irradiation limits are identical to those listed under AC and DC electrical characteristics. These parts may be dose rate sensitive in a space environment and demonstrate enhanced low dose rate effect. Radiation end point limits for the noted parameters are specified only for the conditions as specified in Mil-Std-883, Method 1019

LM101A QML and RH Electrical Characteristics⁽¹⁾ DC Parameters (continued)

The following conditions apply to all parameters, unless otherwise specified

 $V_{CC} = \pm 20V$, $V_{CM} = 0V$, $R_S = 50\Omega$

Symbol	Parameter	Conditions	Notes	Min	Max	Units	Sub-groups
$\pm I_{IB}$	Input Bias Current	$+V_{CC} = 35V$, $-V_{CC} = -5V$, $V_{CM} = -15V$, $R_S = 100K\Omega$		-0.1	75	nA	1, 2
				-0.1	100	nA	3
		$+V_{CC} = 5V$, $-V_{CC} = -35V$, $V_{CM} = +15V$, $R_S = 100K\Omega$		-0.1	75	nA	1, 2
				-0.1	100	nA	3
		$V_{CM} = 0V$, $R_S = 100K\Omega$		-0.1	75	nA	1, 2
				-0.1	100	nA	3
+PSRR	Power Supply Rejection Ratio	$+V_{CC} = 10V$, $-V_{CC} = -20V$		-50	+50	$\mu V/V$	1
				-100	+100	$\mu V/V$	2, 3
-PSRR	Power Supply Rejection Ratio	$+V_{CC} = 20V$, $-V_{CC} = -10V$		-50	+50	$\mu V/V$	1
				-100	+100	$\mu V/V$	2, 3
CMRR	Common Mode Rejection Ratio	$V_{CC} = \pm 35V$ to $\pm 5V$, $V_{CM} = \pm 15V$		80		dB	1, 2, 3
$+V_{IO}$ Adj	Adjustment for Input Offset Voltage			4.0		mV	1, 2, 3
$-V_{IO}$ Adj	Adjustment for Input Offset Voltage				-4.0	mV	1, 2, 3
$+I_{OS}$	Output Short Circuit Current	$+V_{CC} = 15V$, $-V_{CC} = -15V$, $t \leq 25mS$, $V_{CM} = -15V$		-60		mA	1, 2, 3
$-I_{OS}$	Output Short Circuit Current	$+V_{CC} = 15V$, $-V_{CC} = -15V$, $t \leq 25mS$, $V_{CM} = +15V$			+60	mA	1, 2, 3
I_{CC}	Power Supply Current	$+V_{CC} = 15V$, $-V_{CC} = -15V$			3.0	mA	1
					2.32	mA	2
					3.5	mA	3
$\Delta V_{IO} / \Delta T$	Temperature Coefficient of Input Offset Voltage	$-55^\circ C \leq T_A \leq +25^\circ C$	See ⁽²⁾	-18	+18	$\mu V/^\circ C$	2
		$+25^\circ C \leq T_A \leq +125^\circ C$	See ⁽²⁾	-15	+15	$\mu V/^\circ C$	3
$\Delta I_{IO} / \Delta T$	Temperature Coefficient of Input Offset Current	$-55^\circ C \leq T_A \leq +25^\circ C$	See ⁽²⁾	-200	+200	$\mu A/^\circ C$	2
		$+25^\circ C \leq T_A \leq +125^\circ C$	See ⁽²⁾	-100	+100	$\mu A/^\circ C$	3
-A _{VS}	Large Signal (Open Loop) Voltage Gain	$R_L = 2K\Omega$, $V_O = -15V$	See ⁽³⁾	50		V/mV	4
			See ⁽³⁾	25		V/mV	5, 6
		$R_L = 10K\Omega$, $V_O = -15V$	See ⁽³⁾	50		V/mV	4
			See ⁽³⁾	25		V/mV	5, 6
+A _{VS}	Large Signal (Open Loop) Voltage Gain	$R_L = 2K\Omega$, $V_O = +15V$	See ⁽³⁾	50		V/mV	4
			See ⁽³⁾	25		V/mV	5, 6
		$R_L = 10K\Omega$, $V_O = +15V$	See ⁽³⁾	50		V/mV	4
			See ⁽³⁾	25		V/mV	5, 6
A _{VS}	Large Signal (Open Loop) Voltage Gain	$V_{CC} = \pm 5V$, $R_L = 2K\Omega$, $V_O = \pm 2V$	See ⁽³⁾	10		V/mV	4, 5, 6
		$V_{CC} = \pm 5V$, $R_L = 10K\Omega$, $V_O = \pm 2V$	See ⁽³⁾	10		V/mV	4, 5, 6
+V _{OP}	Output Voltage Swing	$R_L = 10K\Omega$, $V_{CM} = -20V$		+16		V	4, 5, 6
		$R_L = 2K\Omega$, $V_{CM} = -20V$		+15		V	4, 5, 6
-V _{OP}	Output Voltage Swing	$R_L = 10K\Omega$, $V_{CM} = 20V$			-16	V	4, 5, 6
		$R_L = 2K\Omega$, $V_{CM} = 20V$			-15	V	4, 5, 6

(2) Calculated parameter

 (3) Datalog reading of $K = V/mV$.

LM101A QM and RH Electrical Characteristics AC Parameters

The following conditions apply to all parameters, unless otherwise specified

$$V_{CC} = \pm 20V, V_{CM} = 0V, R_S = 50\Omega$$

Symbol	Parameter	Conditions	Notes	Min	Max	Units	Sub-groups
+SR	Slew Rate	$A_V = 1, V_I = -5V \text{ to } +5V$		0.3		V/ μ S	7, 8A
				0.2		V/ μ S	8B
-SR	Slew Rate	$A_V = 1, V_I = +5V \text{ to } -5V$		0.3		V/ μ S	7, 8A
				0.2		V/ μ S	8B
TR _{TR}	Rise Time	$A_V = 1, V_I = 50mV$			800	nS	7, 8A, 8B
TR _{OS}	Overshoot	$A_V = 1, V_I = 50mV$			25	%	7
					35	%	8A, 8B
NI _{BB}	Noise Broadband	$BW = 10Hz \text{ to } 5KHz, R_S = 0\Omega$			15	μV_{RMS}	7
NI _{PC}	Noise Popcorn	$BW = 10Hz \text{ to } 5KHz, R_S = 100K\Omega$			80	μV_{PK}	7

LM101A QM and RH Electrical Characteristics DC Parameters Drift Values

The following conditions apply to all parameters, unless otherwise specified

$$V_{CC} = \pm 20V, V_{CM} = 0V, R_S = 50\Omega$$

Delta calculations performed on QMLV devices at group B, Subgroup 5 only.

Symbol	Parameter	Conditions	Notes	Min	Max	Units	Sub-groups
V _{IO}	Input Offset Voltage	$V_{CM} = 0V$		-0.5	0.5	mV	1
$\pm I_B$	Input Bias Current	$V_{CM} = 0V, R_S = 100K\Omega$		-7.5	7.5	nA	1

Typical Performance Characteristics LM101A

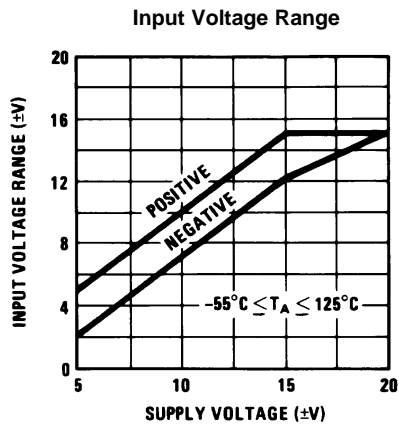

Figure 4.

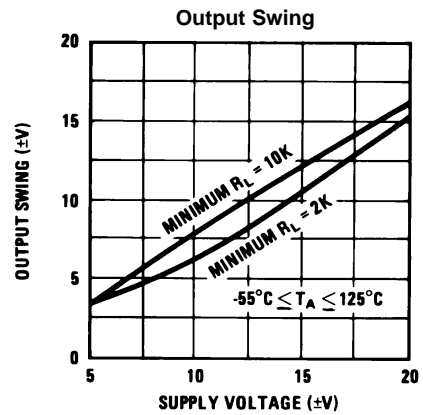

Figure 5.

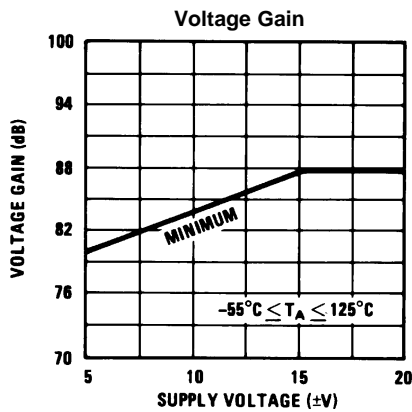

Figure 6.

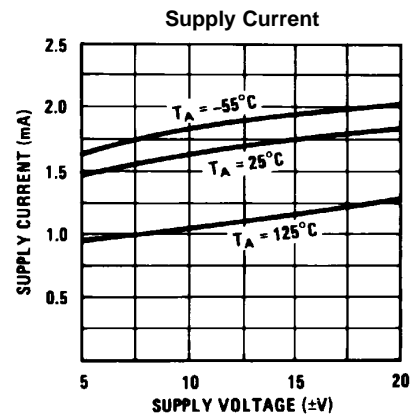

Figure 7.

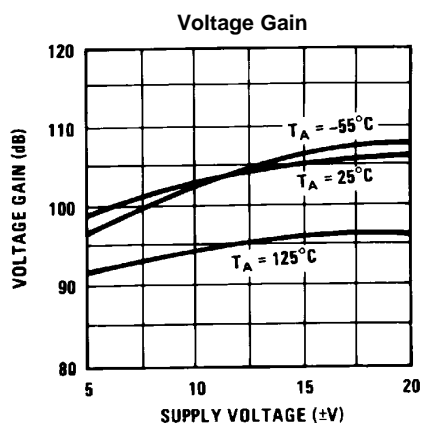

Figure 8.

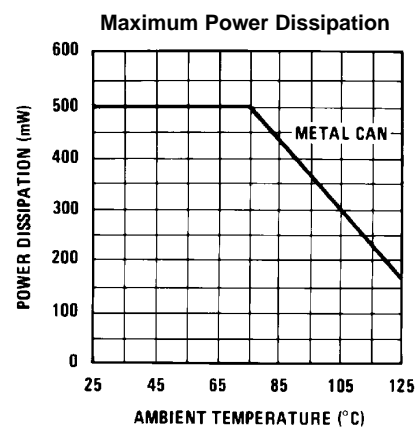

Figure 9.

Typical Performance Characteristics LM101A (continued)

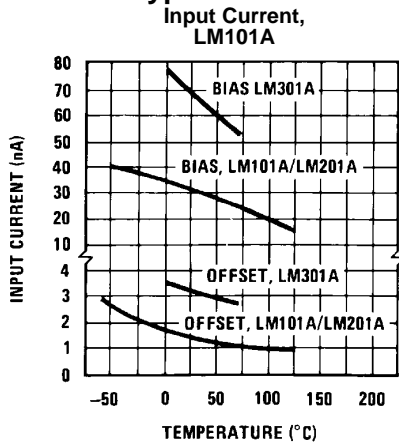

Figure 10.

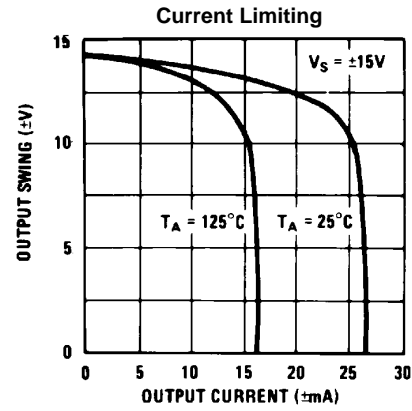

Figure 11.

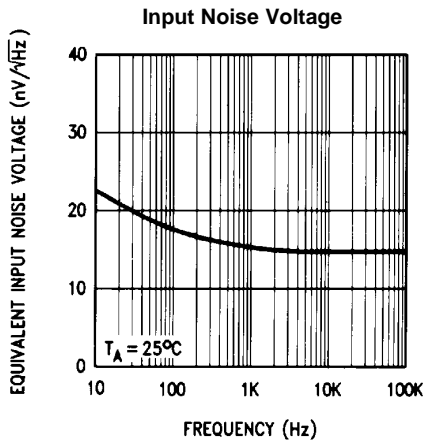

Figure 12.

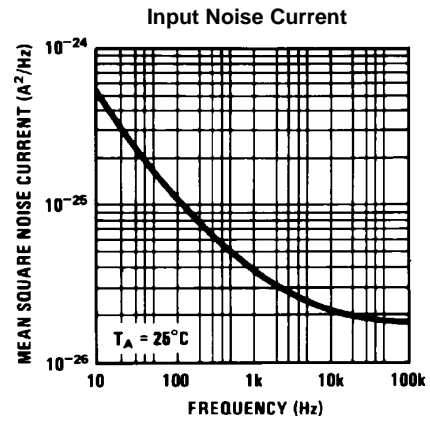

Figure 13.

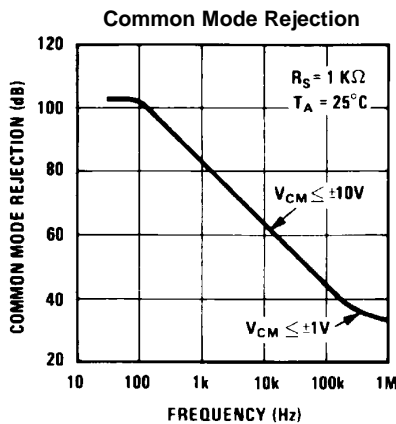

Figure 14.

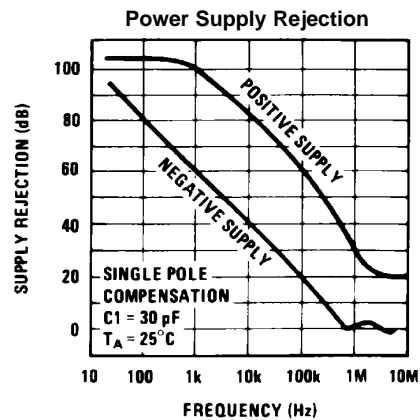

Figure 15.

Typical Performance Characteristics LM101A (continued)
Closed Loop Output Impedance

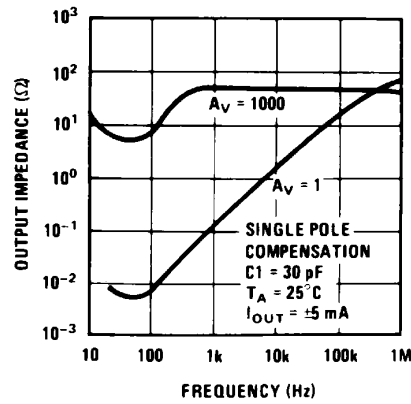
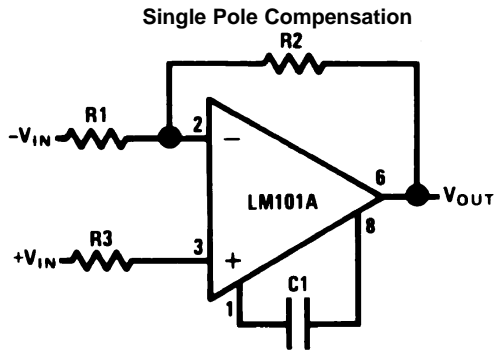

Figure 16.

Typical Performance Characteristics for Various Compensation Circuits

Pin connections shown are for 8-pin packages.



$$C1 \geq \frac{R1 C_S}{R1 + R2}$$

$$C_S = 30 \text{ pF}$$

Figure 17.

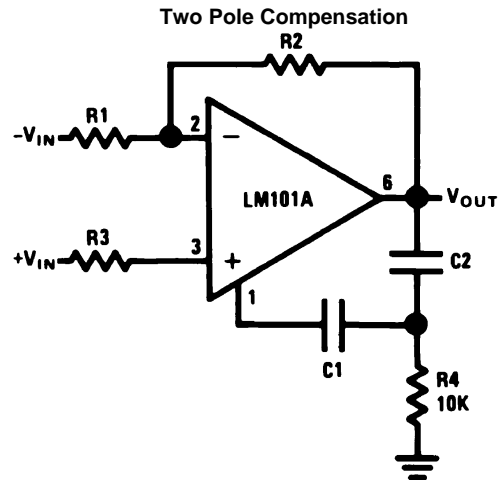

$$C1 \geq \frac{R1 C_S}{R1 + R2}$$

$$C_S = 30 \text{ pF}$$

$$C2 = 10 C1$$

Figure 18.

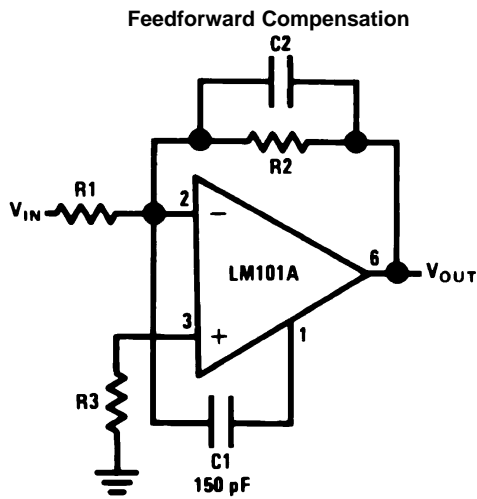

$$C2 = \frac{1}{2\pi f_o R2}$$

$$f_o = 3 \text{ MHz}$$

Figure 19.

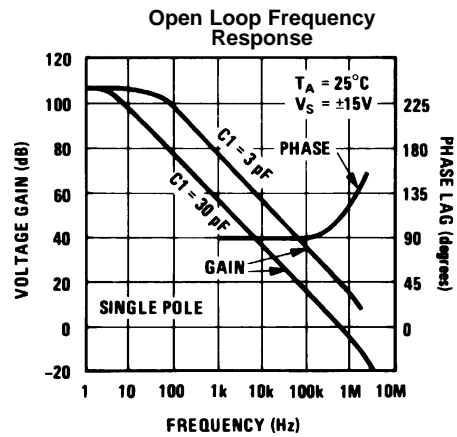

Figure 20.

Typical Performance Characteristics for Various Compensation Circuits (continued)

Pin connections shown are for 8-pin packages.

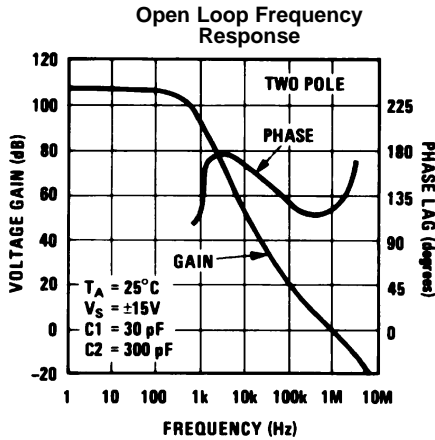

Figure 21.

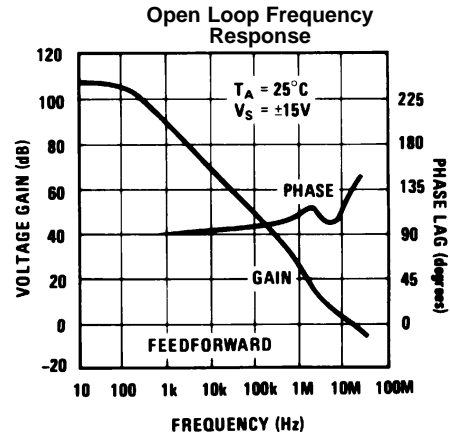

Figure 22.

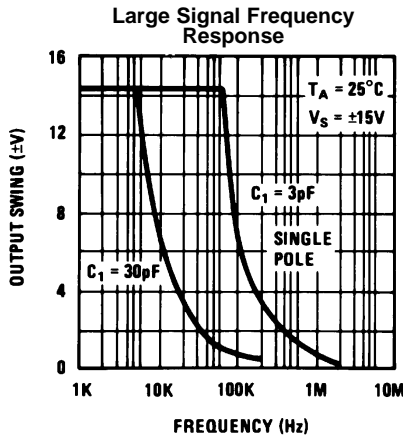

Figure 23.

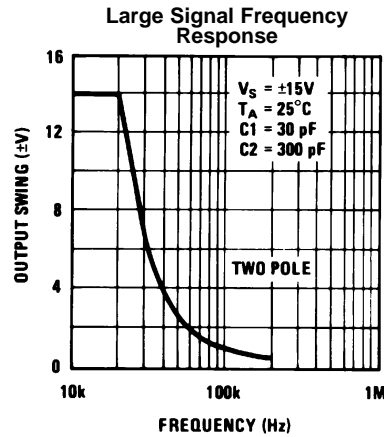

Figure 24.

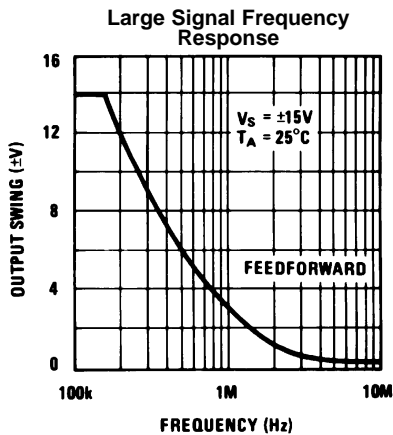

Figure 25.

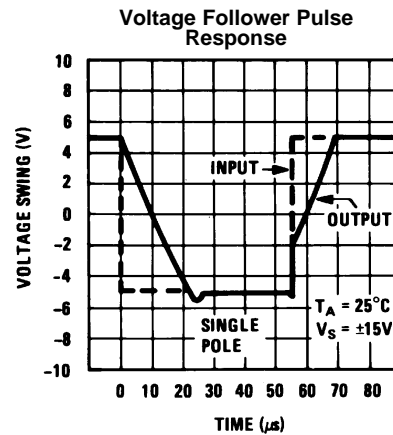
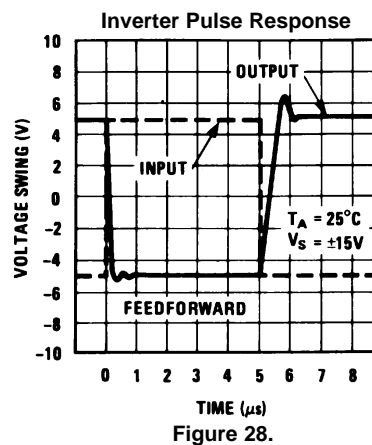
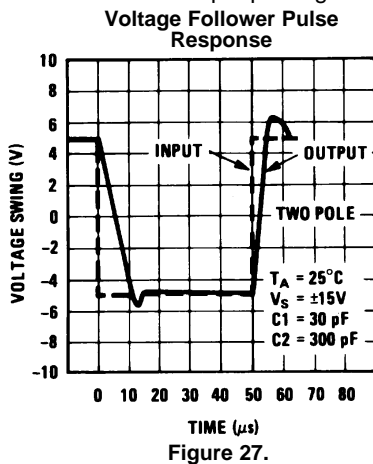

Figure 26.

Typical Performance Characteristics for Various Compensation Circuits (continued)

Pin connections shown are for 8-pin packages.



TYPICAL APPLICATIONS

Pin connections shown are for 8-pin packages.

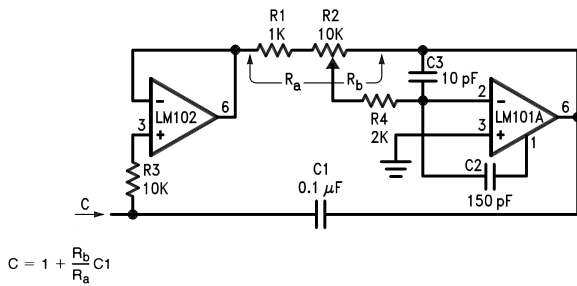

$$C = 1 + \frac{R_b}{R_a} C_1$$

Figure 29. Variable Capacitance Multiplier

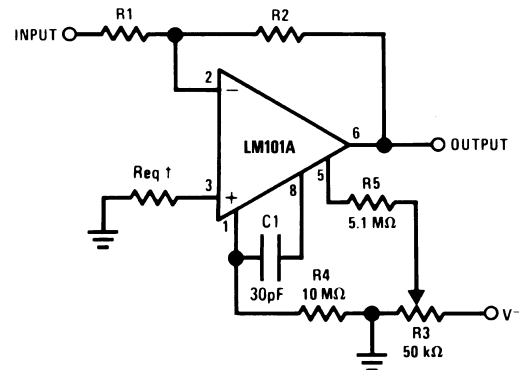

†May be zero or equal to parallel combination of R1 and R2 for minimum offset.

Figure 30. Inverting Amplifier with Balancing Circuit

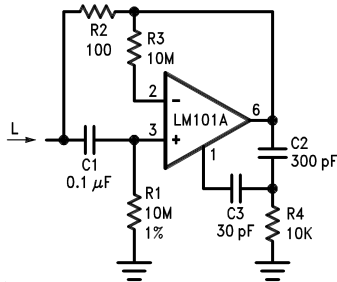

$$L = R_1 R_2 C_1$$

$$R_S = R_2$$

$$R_P = R_1$$

Figure 31. Simulated Inductor

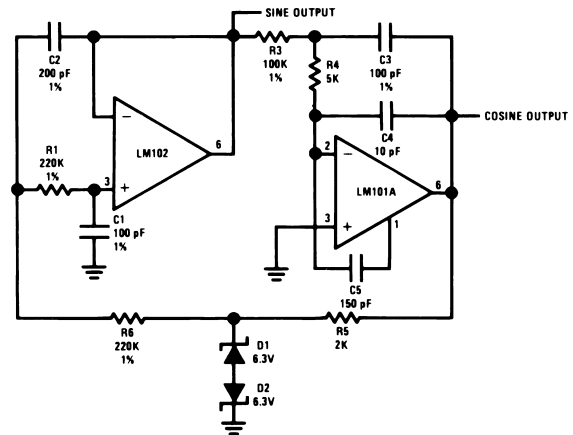

f_o = 10 kHz

Figure 32. Sine Wave Oscillator

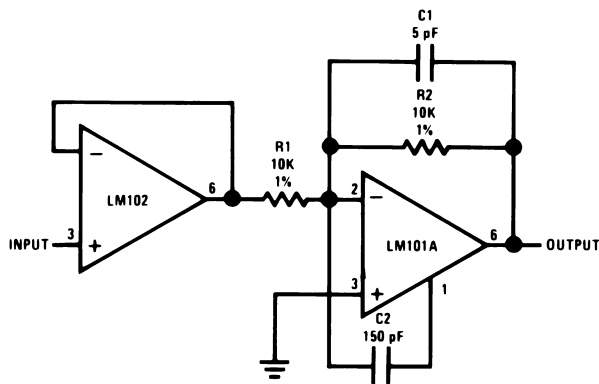
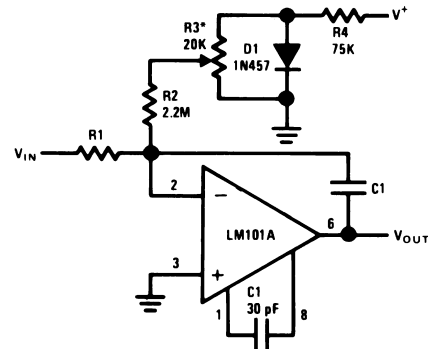

Figure 33. Fast Inverting Amplifier with High Input Impedance



*Adjust for zero integrator drift. Current drift typically 0.1 nA/°C over -55°C to +125°C temperature range.

Figure 34. Integrator with Bias Current Compensation

Application Hints

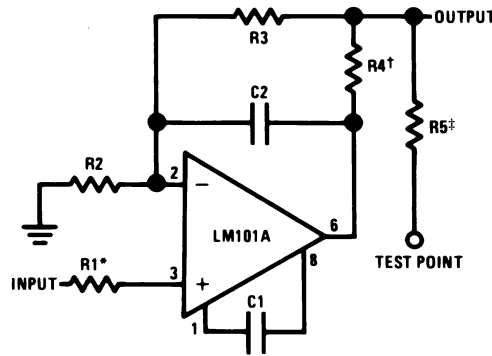

*Protects input

†Protects output

‡Protects output—not needed when R4 is used.

Figure 35. Protecting Against Gross Fault Conditions

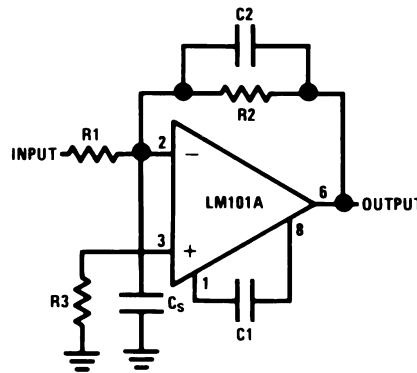

$$C2 = \frac{R1 C_s}{R2}$$

Figure 36. Compensating for Stray Input Capacitances or Large Feedback Resistor

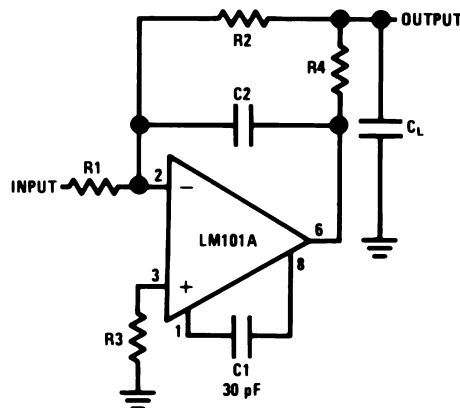

Figure 37. Isolating Large Capacitive Loads

Although the LM101A is designed for trouble free operation, experience has indicated that it is wise to observe certain precautions given below to protect the devices from abnormal operating conditions. It might be pointed out that the advice given here is applicable to practically any IC op amp, although the exact reason why may differ with different devices.

When driving either input from a low-impedance source, a limiting resistor should be placed in series with the input lead to limit the peak instantaneous output current of the source to something less than 100 mA. This is especially important when the inputs go outside a piece of equipment where they could accidentally be connected to high voltage sources. Large capacitors on the input (greater than 0.1 μF) should be treated as a low source impedance and isolated with a resistor. Low impedance sources do not cause a problem unless their output voltage exceeds the supply voltage. However, the supplies go to zero when they are turned off, so the isolation is usually needed.

The output circuitry is protected against damage from shorts to ground. However, when the amplifier output is connected to a test point, it should be isolated by a limiting resistor, as test points frequently get shorted to bad places. Further, when the amplifier drives a load external to the equipment, it is also advisable to use some sort of limiting resistance to preclude mishaps.

Precautions should be taken to insure that the power supplies for the integrated circuit never become reversed—even under transient conditions. With reverse voltages greater than 1V, the IC will conduct excessive current, fusing internal aluminum interconnects. If there is a possibility of this happening, clamp diodes with a high peak current rating should be installed on the supply lines. Reversal of the voltage between V^+ and V^- will always cause a problem, although reversals with respect to ground may also give difficulties in many circuits.

The minimum values given for the frequency compensation capacitor are stable only for source resistances less than 10 k Ω , stray capacitances on the summing junction less than 5 pF and capacitive loads smaller than 100 pF. If any of these conditions are not met, it becomes necessary to overcompensate the amplifier with a larger compensation capacitor. Alternately, lead capacitors can be used in the feedback network to negate the effect of stray capacitance and large feedback resistors or an RC network can be added to isolate capacitive loads.

Although the LM101A is relatively unaffected by supply bypassing, this cannot be ignored altogether. Generally it is necessary to bypass the supplies to ground at least once on every circuit card, and more bypass points may be required if more than five amplifiers are used. When feed-forward compensation is employed, however, it is advisable to bypass the supply leads of each amplifier with low inductance capacitors because of the higher frequencies involved.

Typical Applications

Pin connections shown are for 8-pin packages.

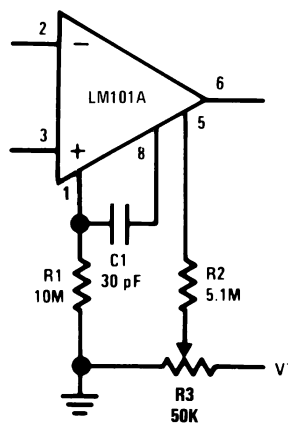
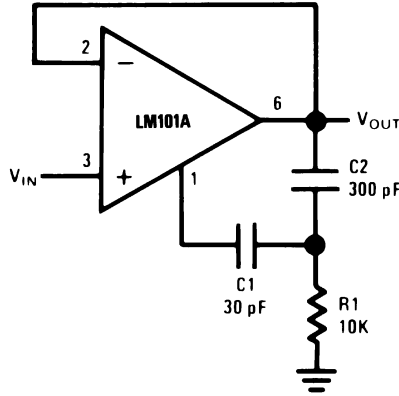
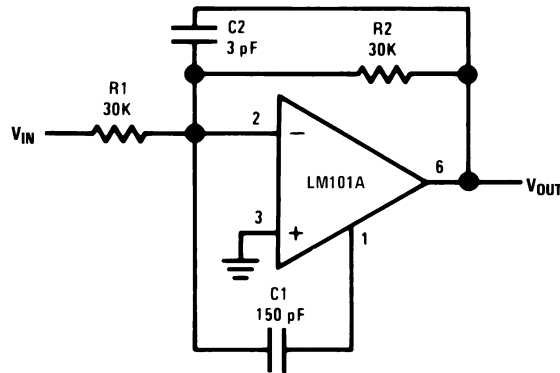

Figure 38. Standard Compensation and Offset Balancing Circuit



Power Bandwidth: 15 kHz
Slew Rate: 1V/μs

Figure 39. Fast Voltage Follower



Power Bandwidth: 250 kHz
Small Signal Bandwidth: 3.5 MHz
Slew Rate: 10V/μs

Figure 40. Fast Summing Amplifier

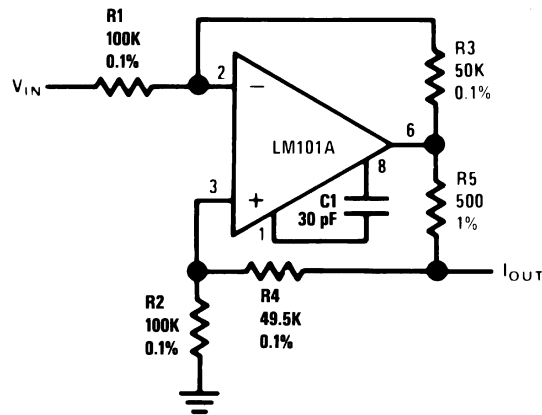

$$I_{OUT} = \frac{R3 V_{IN}}{R1 R5}$$

R3 = R4 + R5
R1 = R2

Figure 41. Bilateral Current Source

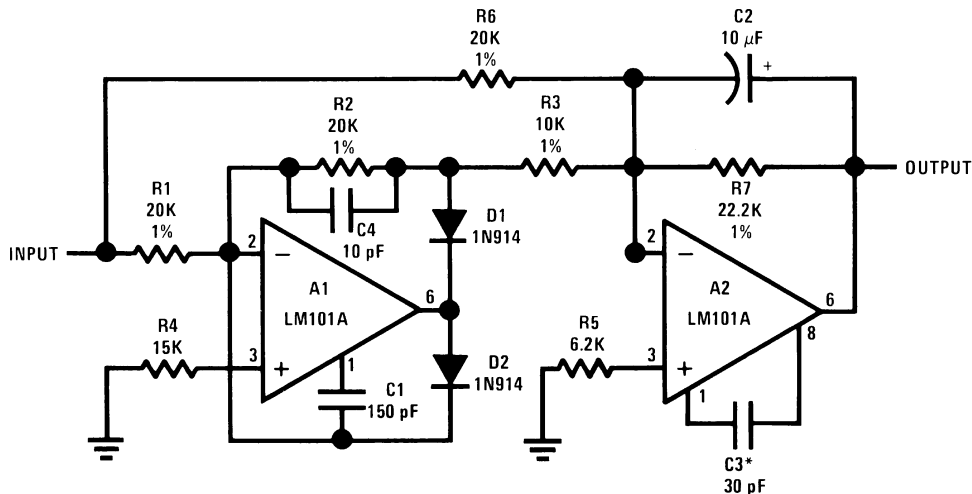

Note: Feedforward compensation can be used to make a fast full wave rectifier without a filter.

Figure 42. Fast AC/DC Converter

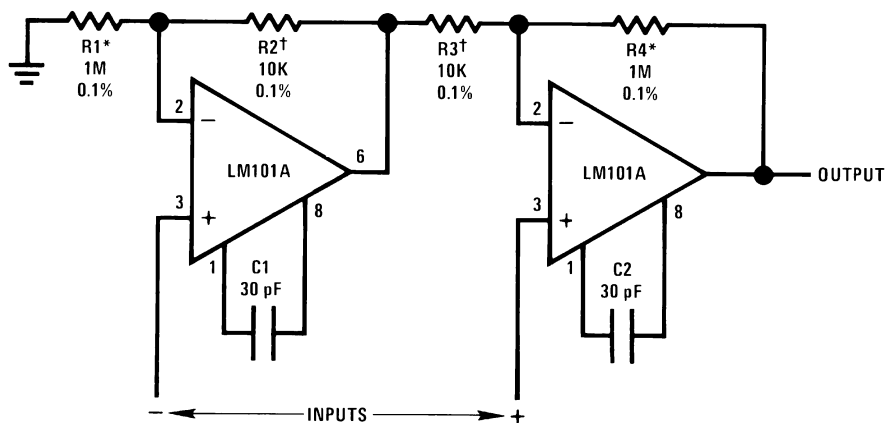

R1 = R4; R2 = R3

$$A_v = 1 + \frac{R1}{R2}$$

*,† Matching determines CMRR.

Figure 43. Instrumentation Amplifier

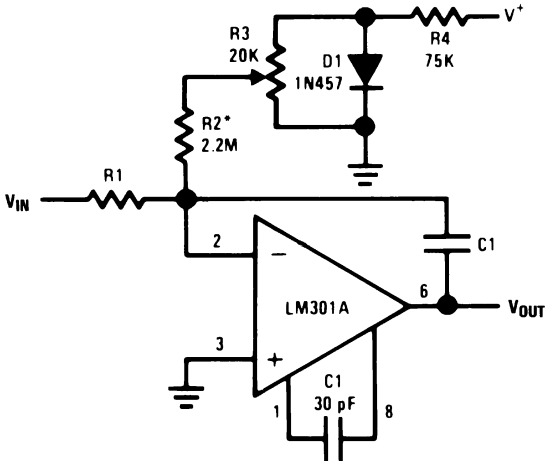

*Adjust for zero integrator drift. Current drift typically 0.1 nA/°C over 0°C to +70°C temperature range.

Figure 44. Integrator with Bias Current Compensation

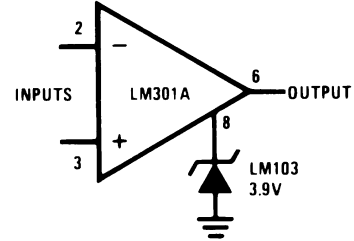

Figure 45. Voltage Comparator for Driving RTL Logic or High Current Driver

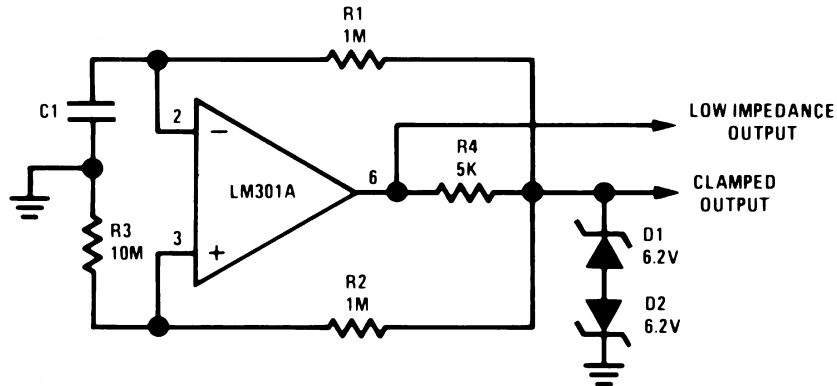
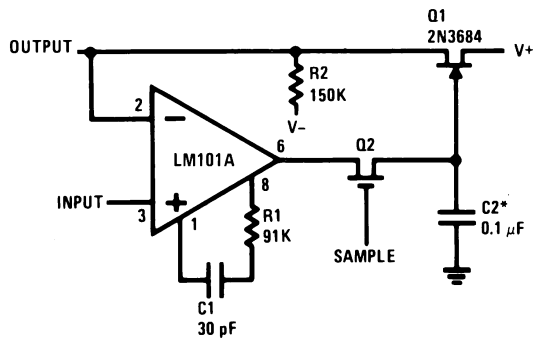

Figure 46. Low Frequency Square Wave Generator



*Polycarbonate-dielectric capacitor

Figure 47. Low Drift Sample and Hold

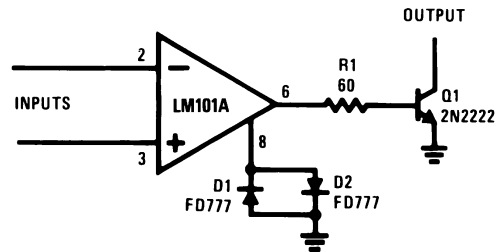

Figure 48. Voltage Comparator for Driving DTL or TTL Integrated Circuits

REVISION HISTORY SECTION

Date Released	Revision	Section	Originator	Changes
01/05/06	A	New Release to corporate format	L. Lytle	2 MDS datasheets converted into one Corp. datasheet format. MNL101A-X Rev 0A0 and MRL101A-X-RH rev 1C2 MDS datasheets will be archived.
03/20/13	A	All	-	Changed layout of National Data Sheet to TI format

PACKAGING INFORMATION

Orderable Device	Status (1)	Package Type	Package Drawing	Pins	Package Qty	Eco Plan (2)	Lead/Ball Finish	MSL Peak Temp (3)	Op Temp (°C)	Top-Side Markings (4)	Samples
5962L9951501VGA	ACTIVE	TO-99	LMC	8	20	TBD	Call TI	Call TI	-55 to 125	LM101AHLQMLV 5962L9951501VGA Q ACO 5962L9951501VGA Q >T	Samples
5962L9951501VHA	ACTIVE	CLGA	NAD	10	19	TBD	Call TI	Call TI	-55 to 125	LM101AW LQMLV Q 5962L99515 01VHA ACO 01VHA >T	Samples
5962L9951501VPA	ACTIVE	CDIP	NAB	8	40	TBD	Call TI	Call TI	-55 to 125	LM101AJLQMLV 5962L99515 01VPA Q ACO 01VPA Q >T	Samples
LM101AH/883	ACTIVE	TO-99	LMC	8	20	TBD	Call TI	Call TI	-55 to 125	LM101AH/883 Q ACO LM101AH/883 Q >T	Samples
LM101AHLQMLV	ACTIVE	TO-99	LMC	8	20	TBD	Call TI	Call TI	-55 to 125	LM101AHLQMLV 5962L9951501VGA Q ACO 5962L9951501VGA Q >T	Samples
LM101AJ/883	ACTIVE	CDIP	NAB	8	40	TBD	Call TI	Call TI	-55 to 125	(LF412MJ, LM101AJ) /883 Q ACO /883 Q >T	Samples
LM101AJLQMLV	ACTIVE	CDIP	NAB	8	40	TBD	Call TI	Call TI	-55 to 125	LM101AJLQMLV 5962L99515 01VPA Q ACO 01VPA Q >T	Samples
LM101AWLQMLV	ACTIVE	CLGA	NAD	10	19	TBD	Call TI	Call TI	-55 to 125	LM101AW LQMLV Q 5962L99515 01VHA ACO 01VHA >T	Samples

(1) The marketing status values are defined as follows:

ACTIVE: Product device recommended for new designs.

LIFEBUY: TI has announced that the device will be discontinued, and a lifetime-buy period is in effect.

NRND: Not recommended for new designs. Device is in production to support existing customers, but TI does not recommend using this part in a new design.

PREVIEW: Device has been announced but is not in production. Samples may or may not be available.

OBSOLETE: TI has discontinued the production of the device.

(2) Eco Plan - The planned eco-friendly classification: Pb-Free (RoHS), Pb-Free (RoHS Exempt), or Green (RoHS & no Sb/Br) - please check <http://www.ti.com/productcontent> for the latest availability information and additional product content details.

TBD: The Pb-Free/Green conversion plan has not been defined.

Pb-Free (RoHS): TI's terms "Lead-Free" or "Pb-Free" mean semiconductor products that are compatible with the current RoHS requirements for all 6 substances, including the requirement that lead not exceed 0.1% by weight in homogeneous materials. Where designed to be soldered at high temperatures, TI Pb-Free products are suitable for use in specified lead-free processes.

Pb-Free (RoHS Exempt): This component has a RoHS exemption for either 1) lead-based flip-chip solder bumps used between the die and package, or 2) lead-based die adhesive used between the die and leadframe. The component is otherwise considered Pb-Free (RoHS compatible) as defined above.

Green (RoHS & no Sb/Br): TI defines "Green" to mean Pb-Free (RoHS compatible), and free of Bromine (Br) and Antimony (Sb) based flame retardants (Br or Sb do not exceed 0.1% by weight in homogeneous material)

(3) MSL, Peak Temp. -- The Moisture Sensitivity Level rating according to the JEDEC industry standard classifications, and peak solder temperature.

(4) Only one of markings shown within the brackets will appear on the physical device.

Important Information and Disclaimer: The information provided on this page represents TI's knowledge and belief as of the date that it is provided. TI bases its knowledge and belief on information provided by third parties, and makes no representation or warranty as to the accuracy of such information. Efforts are underway to better integrate information from third parties. TI has taken and continues to take reasonable steps to provide representative and accurate information but may not have conducted destructive testing or chemical analysis on incoming materials and chemicals. TI and TI suppliers consider certain information to be proprietary, and thus CAS numbers and other limited information may not be available for release.

In no event shall TI's liability arising out of such information exceed the total purchase price of the TI part(s) at issue in this document sold by TI to Customer on an annual basis.

OTHER QUALIFIED VERSIONS OF LM101AQML, LM101AQML-SP :

- Military: [LM101AQML](#)
- Space: [LM101AQML-SP](#)

NOTE: Qualified Version Definitions:

- Military - QML certified for Military and Defense Applications
- Space - Radiation tolerant, ceramic packaging and qualified for use in Space-based application

NAB0008A

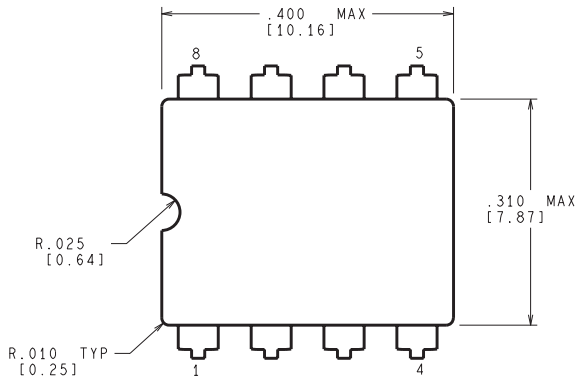

CONTROLLING DIMENSION IS INCH
VALUES IN [] ARE MILLIMETERS

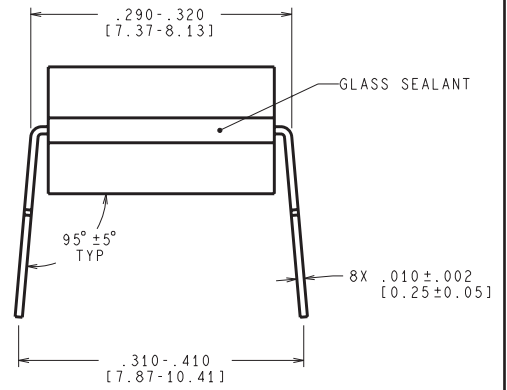
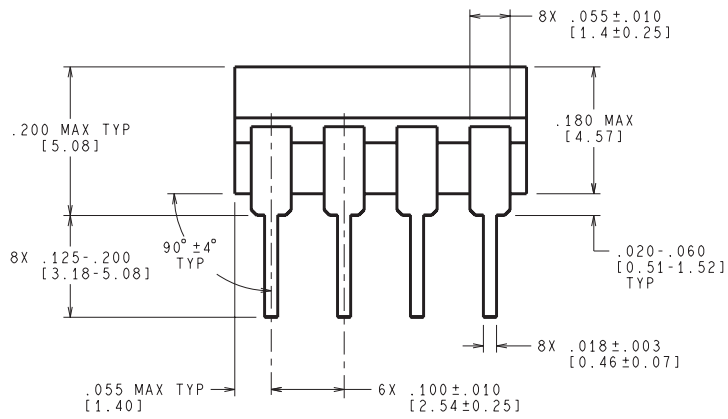

J08A (Rev M)

LMC (O-MBCY-W8)

METAL CYLINDRICAL PACKAGE

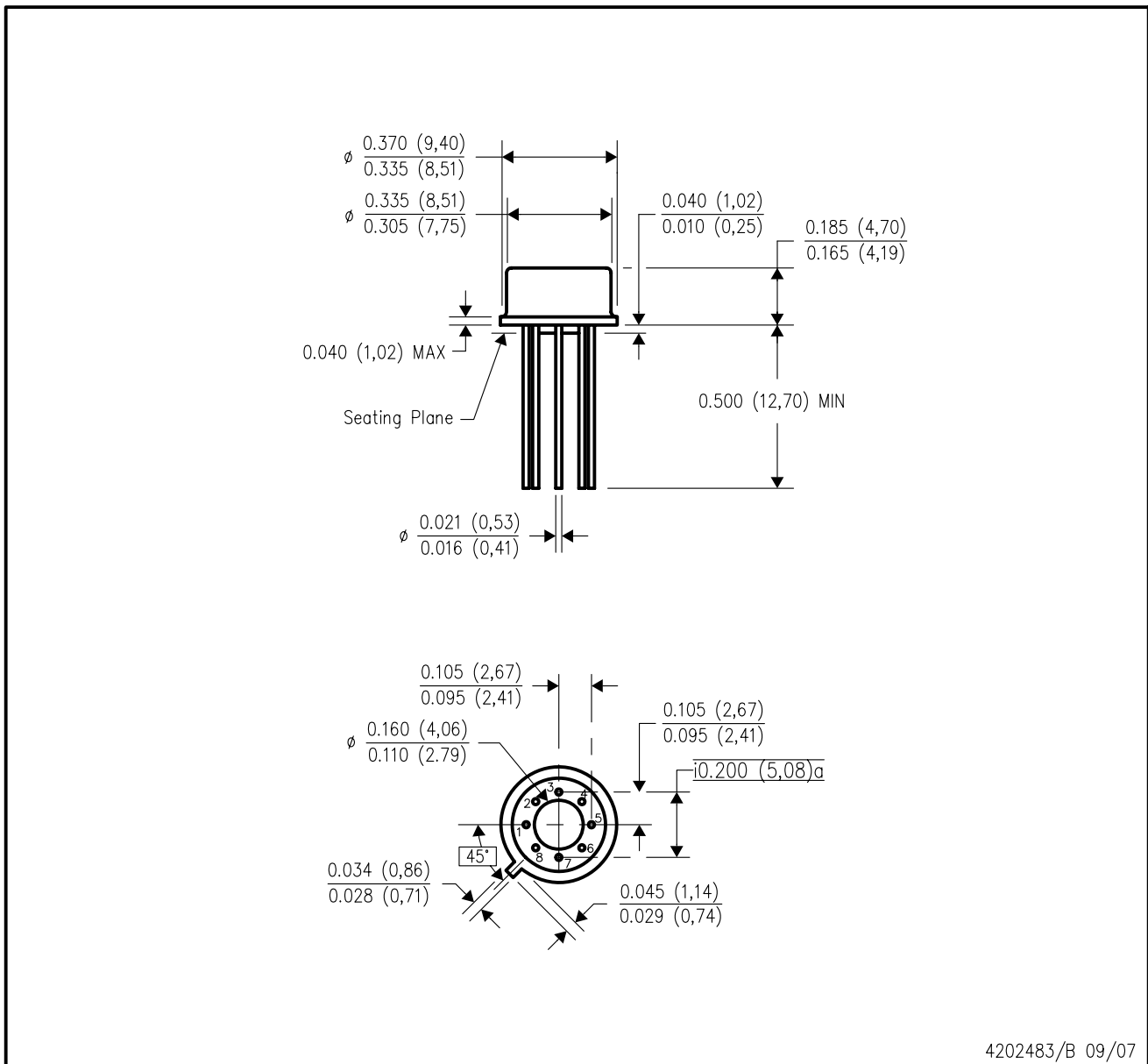

- NOTES:
- A. All linear dimensions are in inches (millimeters).
 - B. This drawing is subject to change without notice.
 - C. Leads in true position within 0.010 (0,25) R @ MMC at seating plane.
 - D. Pin numbers shown for reference only. Numbers may not be marked on package.
 - E. Falls within JEDEC MO-002/TO-99.

IMPORTANT NOTICE

Texas Instruments Incorporated and its subsidiaries (TI) reserve the right to make corrections, enhancements, improvements and other changes to its semiconductor products and services per JESD46, latest issue, and to discontinue any product or service per JESD48, latest issue. Buyers should obtain the latest relevant information before placing orders and should verify that such information is current and complete. All semiconductor products (also referred to herein as "components") are sold subject to TI's terms and conditions of sale supplied at the time of order acknowledgment.

TI warrants performance of its components to the specifications applicable at the time of sale, in accordance with the warranty in TI's terms and conditions of sale of semiconductor products. Testing and other quality control techniques are used to the extent TI deems necessary to support this warranty. Except where mandated by applicable law, testing of all parameters of each component is not necessarily performed.

TI assumes no liability for applications assistance or the design of Buyers' products. Buyers are responsible for their products and applications using TI components. To minimize the risks associated with Buyers' products and applications, Buyers should provide adequate design and operating safeguards.

TI does not warrant or represent that any license, either express or implied, is granted under any patent right, copyright, mask work right, or other intellectual property right relating to any combination, machine, or process in which TI components or services are used. Information published by TI regarding third-party products or services does not constitute a license to use such products or services or a warranty or endorsement thereof. Use of such information may require a license from a third party under the patents or other intellectual property of the third party, or a license from TI under the patents or other intellectual property of TI.

Reproduction of significant portions of TI information in TI data books or data sheets is permissible only if reproduction is without alteration and is accompanied by all associated warranties, conditions, limitations, and notices. TI is not responsible or liable for such altered documentation. Information of third parties may be subject to additional restrictions.

Resale of TI components or services with statements different from or beyond the parameters stated by TI for that component or service voids all express and any implied warranties for the associated TI component or service and is an unfair and deceptive business practice. TI is not responsible or liable for any such statements.

Buyer acknowledges and agrees that it is solely responsible for compliance with all legal, regulatory and safety-related requirements concerning its products, and any use of TI components in its applications, notwithstanding any applications-related information or support that may be provided by TI. Buyer represents and agrees that it has all the necessary expertise to create and implement safeguards which anticipate dangerous consequences of failures, monitor failures and their consequences, lessen the likelihood of failures that might cause harm and take appropriate remedial actions. Buyer will fully indemnify TI and its representatives against any damages arising out of the use of any TI components in safety-critical applications.

In some cases, TI components may be promoted specifically to facilitate safety-related applications. With such components, TI's goal is to help enable customers to design and create their own end-product solutions that meet applicable functional safety standards and requirements. Nonetheless, such components are subject to these terms.

No TI components are authorized for use in FDA Class III (or similar life-critical medical equipment) unless authorized officers of the parties have executed a special agreement specifically governing such use.

Only those TI components which TI has specifically designated as military grade or "enhanced plastic" are designed and intended for use in military/aerospace applications or environments. Buyer acknowledges and agrees that any military or aerospace use of TI components which have **not** been so designated is solely at the Buyer's risk, and that Buyer is solely responsible for compliance with all legal and regulatory requirements in connection with such use.

TI has specifically designated certain components as meeting ISO/TS16949 requirements, mainly for automotive use. In any case of use of non-designated products, TI will not be responsible for any failure to meet ISO/TS16949.

Products

Audio	www.ti.com/audio
Amplifiers	amplifier.ti.com
Data Converters	dataconverter.ti.com
DLP® Products	www.dlp.com
DSP	dsp.ti.com
Clocks and Timers	www.ti.com/clocks
Interface	interface.ti.com
Logic	logic.ti.com
Power Mgmt	power.ti.com
Microcontrollers	microcontroller.ti.com
RFID	www.ti-rfid.com
OMAP Applications Processors	www.ti.com/omap
Wireless Connectivity	www.ti.com/wirelessconnectivity

Applications

Automotive and Transportation	www.ti.com/automotive
Communications and Telecom	www.ti.com/communications
Computers and Peripherals	www.ti.com/computers
Consumer Electronics	www.ti.com/consumer-apps
Energy and Lighting	www.ti.com/energy
Industrial	www.ti.com/industrial
Medical	www.ti.com/medical
Security	www.ti.com/security
Space, Avionics and Defense	www.ti.com/space-avionics-defense
Video and Imaging	www.ti.com/video

TI E2E Community

e2e.ti.com