



STM706T/S/R, STM706P, STM708T/S/R

3 V supervisor

Features

- Precision V_{CC} monitor
 - STM706/708
 - T: $3.00\text{ V} \leq V_{RST} \leq 3.15\text{ V}$
 - S: $2.88\text{ V} \leq V_{RST} \leq 3.00\text{ V}$
 - R: STM706P: $2.59\text{ V} \leq V_{RST} \leq 2.70\text{ V}$
- RST and $\overline{\text{RST}}$ outputs
- 200 ms (typ) t_{rec}
- Watchdog timer - 1.6 s (typ)
- Manual reset input ($\overline{\text{MR}}$)
- Power-fail comparator (PFI/ $\overline{\text{PFO}}$)
- Low supply current - 40 μA (typ)
- Guaranteed $\overline{\text{RST}}$ (RST) assertion down to $V_{CC} = 1.0\text{ V}$
- Operating temperature: $-40\text{ }^\circ\text{C}$ to $85\text{ }^\circ\text{C}$ (industrial grade)

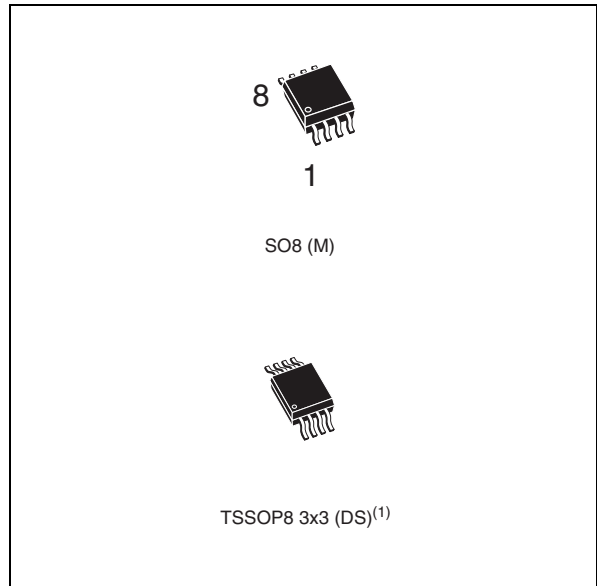

Table 1. Device summary

	Watchdog input	Watchdog output ⁽¹⁾	Active-low RST ⁽¹⁾	Active-high RST ⁽¹⁾	Manual reset input	Power-fail comparator
STM706T/S/R	✓	✓	✓		✓	✓
STM706P ⁽²⁾	✓	✓		✓	✓	✓
STM708T/S/R			✓	✓	✓	✓

1. Push-pull output

2. The STM706P is identical to the STM706R, except its reset output is active-high.

Contents

1	Description	5
2	Pin descriptions	8
2.1	$\overline{\text{MR}}$	8
2.2	WDI	8
2.3	$\overline{\text{WDO}}$	8
2.4	$\overline{\text{RST}}$	8
2.5	RST	8
2.6	PFI	8
2.7	$\overline{\text{PFO}}$	9
3	Operation	11
3.1	Reset output	11
3.2	Push-button reset input	11
3.3	Watchdog input (STM706T/S/R and STM706P)	11
3.4	Watchdog output (STM706T/S/R and STM706P)	11
3.5	Power-fail input/output	12
3.6	Ensuring a valid reset output down to $V_{\text{CC}} = 0 \text{ V}$	12
3.7	Interfacing to microprocessors with bi-directional reset pins	13
4	Typical operating characteristics	14
5	Maximum ratings	22
6	DC and AC parameters	23
7	Package mechanical data	27
8	Part numbering	30
9	Revision history	32

List of tables

Table 1.	Device summary	1
Table 2.	Signal names	6
Table 3.	Pin description	9
Table 4.	Absolute maximum ratings	22
Table 5.	Operating and AC measurement conditions.	23
Table 6.	DC and AC characteristics	25
Table 7.	SO8 - 8-lead plastic small outline, 150 mils body width, package mechanical data.	28
Table 8.	TSSOP8 - 8-lead, thin shrink small outline, 3 x 3 mm body size, mechanical data	29
Table 9.	Ordering information scheme	30
Table 10.	Marking description.	31
Table 11.	Document revision history	32

List of figures

Figure 1.	Logic diagram (STM706T/S/R and STM706P)	5
Figure 2.	Logic diagram (STM708T/S/R)	5
Figure 3.	STM706T/S/R and STM706P SO8 connections	6
Figure 4.	STM706T/S/R and STM706P TSSOP8 connections	6
Figure 5.	STM708T/S/R SO8 connections	7
Figure 6.	STM708T/S/R TSSOP8 connections	7
Figure 7.	Block diagram (STM706T/S/R and STM706P)	9
Figure 8.	Block diagram (STM708T/S/R)	10
Figure 9.	Hardware hookup	10
Figure 10.	Reset output valid to ground circuit	12
Figure 11.	Interfacing to microprocessors with bi-directional reset I/O	13
Figure 12.	Supply current vs. temperature (no load)	14
Figure 13.	V_{PFI} threshold vs. temperature	15
Figure 14.	Reset comparator propagation delay vs. temperature	15
Figure 15.	Power-up t_{rec} vs. temperature	16
Figure 16.	Normalized reset threshold vs. temperature	16
Figure 17.	Watchdog time-out period vs. temperature	17
Figure 18.	PFI to PFO propagation delay vs. temperature	17
Figure 19.	Output voltage vs. load current ($V_{CC} = 5\text{ V}$; $V_{BAT} = 2.8\text{ V}$; $T_A = 25\text{ }^\circ\text{C}$)	18
Figure 20.	Output voltage vs. load current ($V_{CC} = 0\text{ V}$; $V_{BAT} = 2.8\text{ V}$; $T_A = 25\text{ }^\circ\text{C}$)	18
Figure 21.	\overline{RST} output voltage vs. supply voltage	19
Figure 22.	RST output voltage vs. supply voltage	19
Figure 23.	Power-fail comparator response time (assertion)	20
Figure 24.	Power-fail comparator response time (de-assertion)	20
Figure 25.	Maximum transient duration vs. reset threshold overdrive	21
Figure 26.	AC testing input/output waveforms	23
Figure 27.	Power-fail comparator waveform	23
Figure 28.	MR timing waveform	24
Figure 29.	Watchdog timing (STM706T/S/R and STM706P)	24
Figure 30.	SO8 – 8-lead plastic small outline, 150 mils body width, package mechanical	28
Figure 31.	TSSOP8 – 8-lead, thin shrink small outline, 3 x 3 mm body size, outline	29

1 Description

The STM70x supervisors are self-contained devices which provide microprocessor supervisory functions. A precision voltage reference and comparator monitors the V_{CC} input for an out-of-tolerance condition. When an invalid V_{CC} condition occurs, the reset output (\overline{RST}) is forced low (or high in the case of RST).

These devices also offer a watchdog timer (except for STM708T/S/R) as well as a power-fail comparator to provide the system with an early warning of impending power failure.

The STM706P is identical to the STM706R, except its reset output is active-high. These devices are available in a standard 8-pin SOIC package or a space-saving 8-pin TSSOP package.

Figure 1. Logic diagram (STM706T/S/R and STM706P)

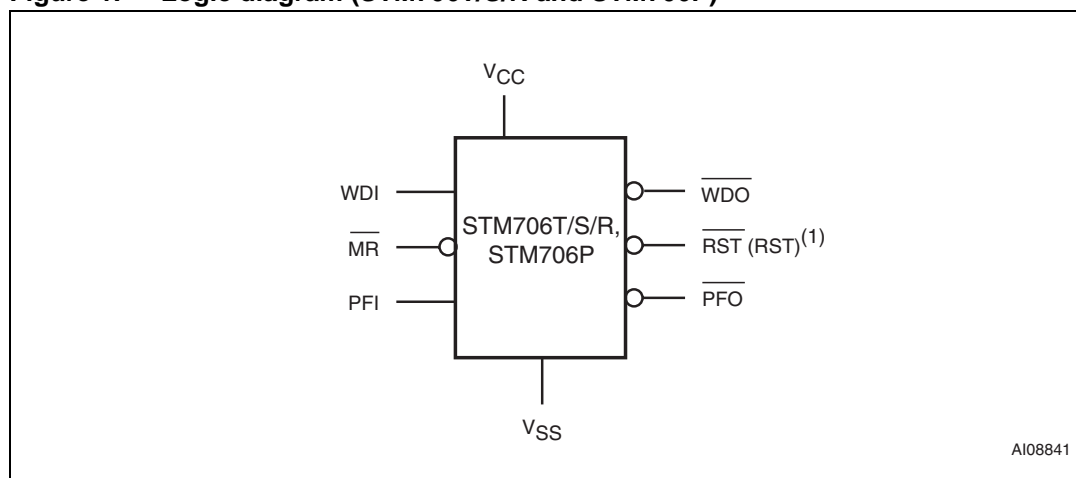

1. For STM706P only.

Figure 2. Logic diagram (STM708T/S/R)

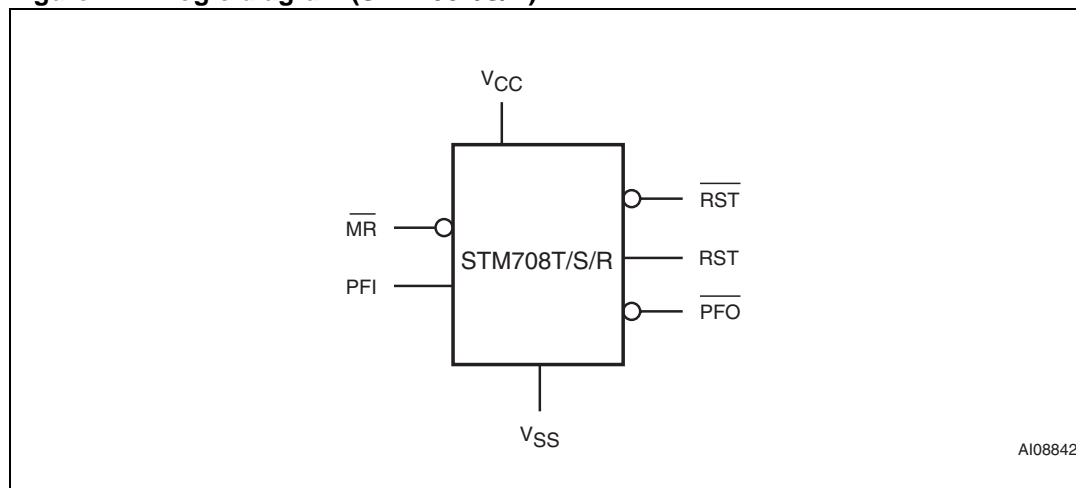
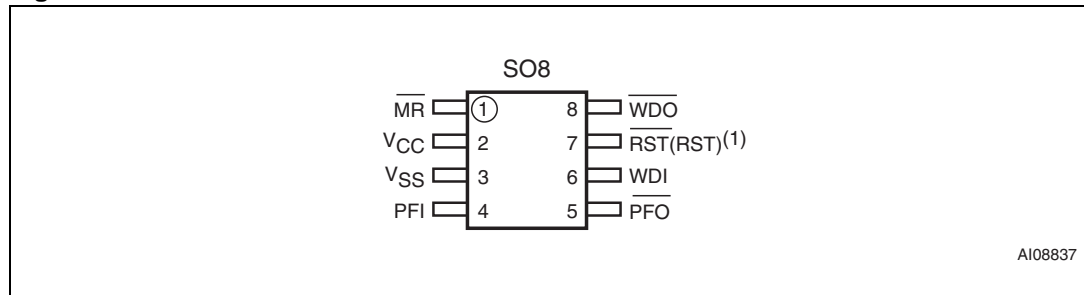

Table 2. Signal names

$\overline{\text{MR}}$	Push-button reset input
WDI	Watchdog input
$\overline{\text{WDO}}$	Watchdog output
$\overline{\text{RST}}$	Active-low reset output
RST ⁽¹⁾	Active-high reset output
V _{CC}	Supply voltage
PFI	Power-fail input
$\overline{\text{PFO}}$	Power-fail output
V _{SS}	Ground
NC	No connect

1. For STM706P and STM708T/S/R only.

Figure 3. STM706T/S/R and STM706P SO8 connections



1. For STM706P reset output is active-high.

Figure 4. STM706T/S/R and STM706P TSSOP8 connections

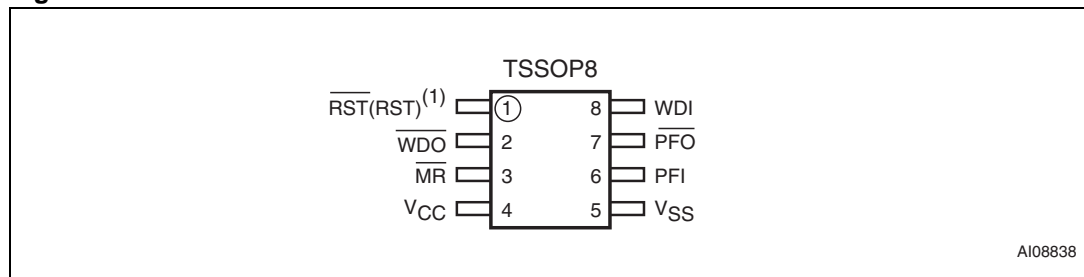

1. For STM706P reset output is active-high.

Figure 5. STM708T/S/R SO8 connections

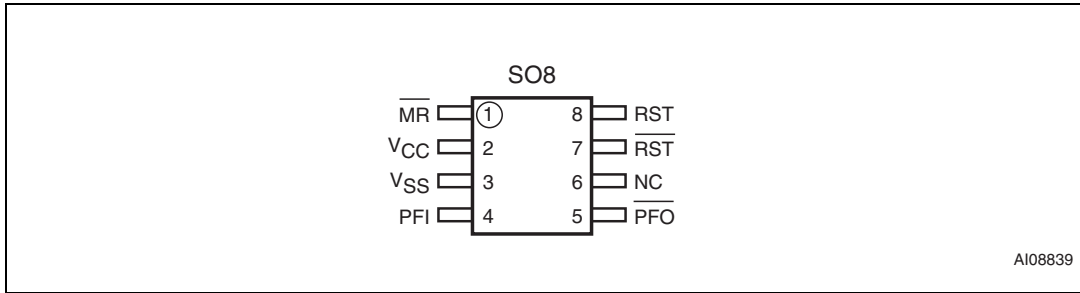
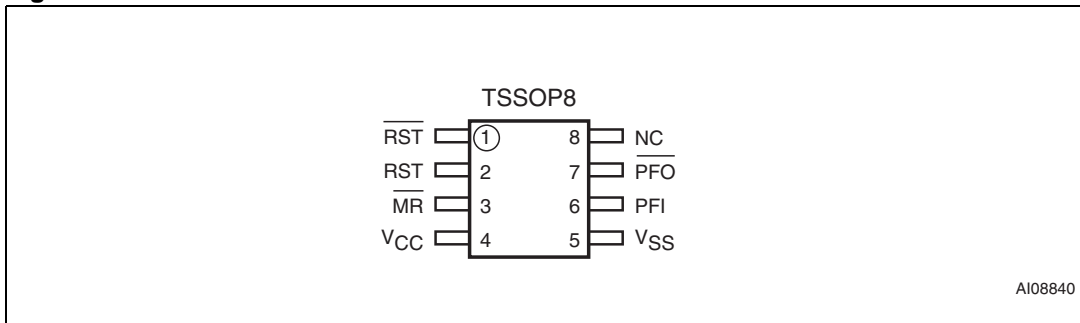

Figure 6. STM708T/S/R TSSOP8 connections



2 Pin descriptions

2.1 $\overline{\text{MR}}$

A logic low on $\overline{\text{MR}}$ asserts the reset output. Reset remains asserted as long as $\overline{\text{MR}}$ is low and for t_{rec} after $\overline{\text{MR}}$ returns high. This active-low input has an internal pull-up. It can be driven from a TTL or CMOS logic line, or shorted to ground with a switch. Leave open if unused.

2.2 WDI

If WDI remains high or low for 1.6 s, the internal watchdog timer runs out and reset (or $\overline{\text{WDO}}$) is triggered. The internal watchdog timer clears while reset is asserted or when WDI sees a rising or falling edge.

The watchdog function cannot be disabled by allowing the WDI pin to float.

2.3 $\overline{\text{WDO}}$

$\overline{\text{WDO}}$ goes low when a transition does not occur on WDI within 1.6 s, and remains low until a transition occurs on WDI (indicating the watchdog interrupt has been serviced). $\overline{\text{WDO}}$ also goes low when V_{CC} falls below the reset threshold; however, unlike the reset output, $\overline{\text{WDO}}$ goes high as soon as V_{CC} exceeds the reset threshold. Output type is push-pull.

Note: *Note: For those devices with a $\overline{\text{WDO}}$ output, a watchdog timeout will not trigger reset unless $\overline{\text{WDO}}$ is connected to $\overline{\text{MR}}$.*

2.4 $\overline{\text{RST}}$

Pulses low for t_{rec} when triggered, and stays low whenever V_{CC} is below the reset threshold or when $\overline{\text{MR}}$ is a logic low. It remains low for t_{rec} after either V_{CC} rises above the reset threshold, the watchdog triggers a reset, or $\overline{\text{MR}}$ goes from low to high.

2.5 RST

Pulses high for t_{rec} when triggered, and stays high whenever V_{CC} is above the reset threshold or when $\overline{\text{MR}}$ is a logic high. It remains high for t_{rec} after either V_{CC} falls below the reset threshold, the watchdog triggers a reset, or $\overline{\text{MR}}$ goes from high to low.

2.6 PFI

When PFI is less than V_{PFI} , $\overline{\text{PFO}}$ goes low; otherwise, $\overline{\text{PFO}}$ remains high. Connect to ground if unused.

2.7 $\overline{\text{PFO}}$

When PFI is less than V_{PFI} , $\overline{\text{PFO}}$ goes low; otherwise, $\overline{\text{PFO}}$ remains high. Leave open if unused. Output type is push-pull.

Table 3. Pin description

Pin						Name	Function
STM706P		STM706T/S/R		STM708T/S/R			
SO8	TSSOP8	SO8	TSSOP8	SO8	TSSOP8		
1	3	1	3	1	3	$\overline{\text{MR}}$	Push-button reset input
6	8	6	8	—	—	WDI	Watchdog input
8	2	8	2	—	—	$\overline{\text{WDO}}$	Watchdog output (push-pull)
—	—	7	1	7	1	$\overline{\text{RST}}$	Active-low reset output
7	1	—	—	8	2	RST	Active-high reset output
2	4	2	4	2	4	V_{CC}	Supply voltage
4	6	4	6	4	6	PFI	Power-fail input
5	7	5	7	5	7	$\overline{\text{PFO}}$	Power-fail output (push-pull)
3	5	3	5	3	5	V_{SS}	Ground
—	—	—	—	6	8	NC	No connect

Figure 7. Block diagram (STM706T/S/R and STM706P)

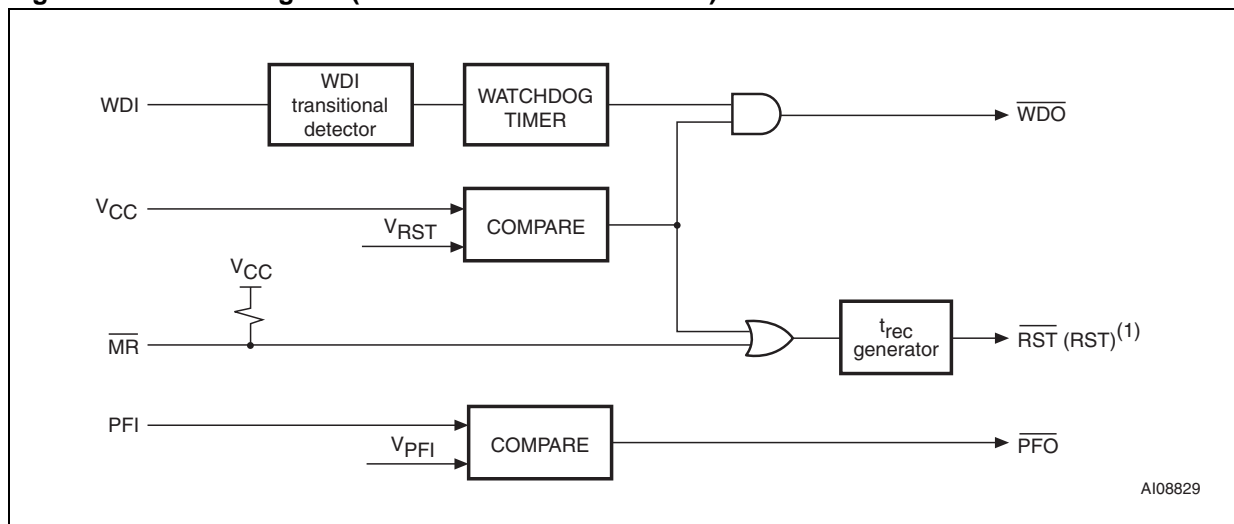

1. For STM706P only.

Figure 8. Block diagram (STM708T/S/R)

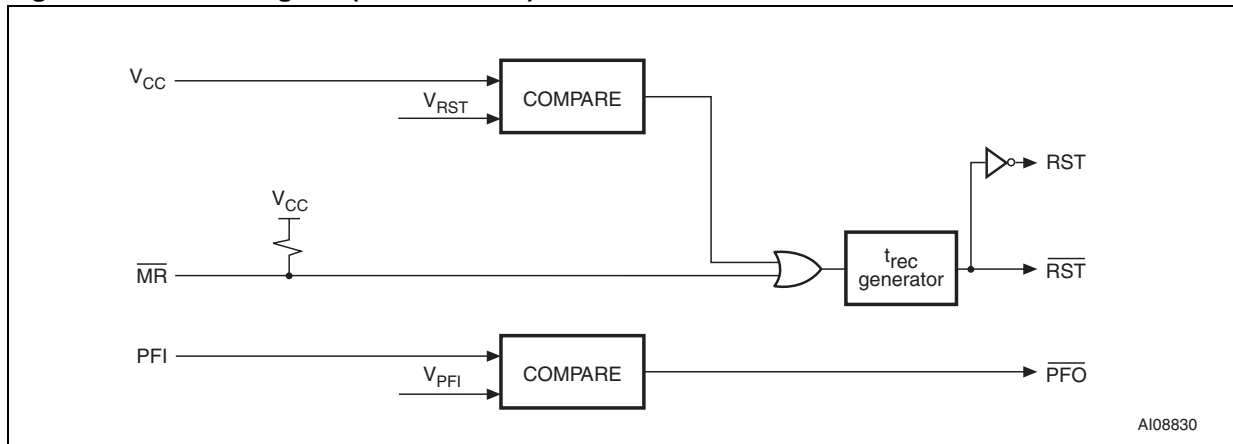
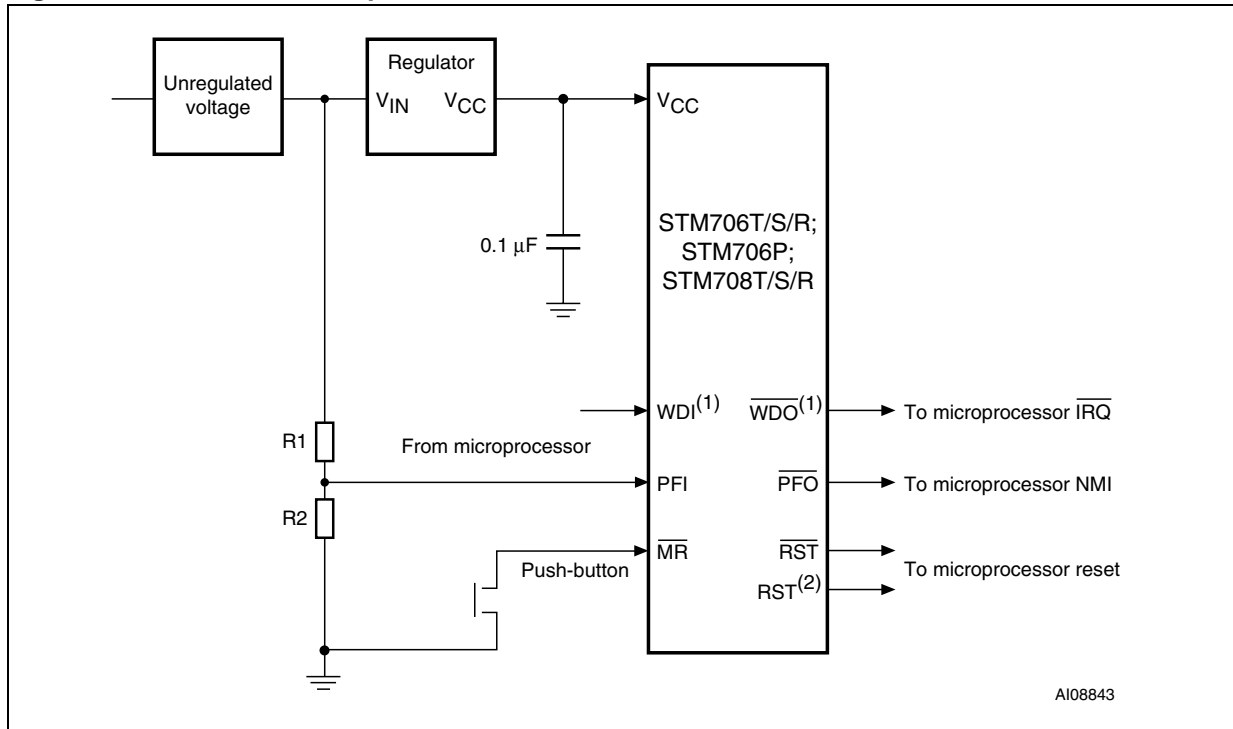

Figure 9. Hardware hookup



1. For STM706T/S/R and STM706P.
2. For STM706P and STM708T/S/R.

3 Operation

3.1 Reset output

The STM70x supervisor asserts a reset signal to the MCU whenever V_{CC} goes below the reset threshold (V_{RST}), a watchdog time-out occurs (if \overline{WDO} is connected to \overline{MR}), or when the push-button reset input (\overline{MR}) is taken low. \overline{RST} is guaranteed to be a logic low (logic high for STM706P and STM708T/S/R) for $V_{CC} < V_{RST}$ down to $V_{CC} = 1$ V for $T_A = 0$ °C to 85 °C.

During power-up, once V_{CC} exceeds the reset threshold an internal timer keeps \overline{RST} low for the reset time-out period, t_{rec} . After this interval \overline{RST} returns high.

If V_{CC} drops below the reset threshold, \overline{RST} goes low. Each time \overline{RST} is asserted, it stays low for at least the reset time-out period (t_{rec}). Any time V_{CC} goes below the reset threshold the internal timer clears. The reset timer starts when V_{CC} returns above the reset threshold.

3.2 Push-button reset input

A logic low on \overline{MR} asserts reset. Reset remains asserted while \overline{MR} is low, and for t_{rec} (see [Figure 28](#)) after it returns high. The \overline{MR} input has an internal 40k Ω pull-up resistor, allowing it to be left open if not used. This input can be driven with TTL/CMOS-logic levels or with open-drain / collector outputs. Connect a normally open momentary switch from \overline{MR} to GND to create a manual reset function; external debounce circuitry is not required. If \overline{MR} is driven from long cables or the device is used in a noisy environment, connect a 0.1 μ F capacitor from \overline{MR} to GND to provide additional noise immunity. \overline{MR} may float, or be tied to V_{CC} when not used.

3.3 Watchdog input (STM706T/S/R and STM706P)

The watchdog timer can be used to detect an out-of-control MCU. If the MCU does not toggle the watchdog input (WDI) within t_{WPD} (1.6 s), the watchdog output pin (\overline{WDO}) is asserted. The internal 1.6s timer is cleared by either:

1. a reset pulse, or
2. by toggling WDI (high-to-low or low-to-high), which can detect pulses as short as 50 ns.

See [Figure 29](#) for STM706T/S/R and STM706P.

The timer remains cleared and does not count for as long as reset is asserted. As soon as reset is released, the timer starts counting.

3.4 Watchdog output (STM706T/S/R and STM706P)

When V_{CC} drops below the reset threshold, \overline{WDO} will go low even if the watchdog timer has not yet timed out. However, unlike the reset output, \overline{WDO} goes high as soon as V_{CC} exceeds the reset threshold. \overline{WDO} may be used to generate a reset pulse by connecting it to the \overline{MR} input.

3.5 Power-fail input/output

The power-fail input (PFI) is compared to an internal reference voltage (independent from the V_{RST} comparator). If PFI is less than the power-fail threshold (V_{PFI}), the power-fail output (\overline{PFO}) will go low. This function is intended for use as an undervoltage detector to signal a failing power supply. Typically PFI is connected through an external voltage divider (see [Figure 9](#)) to either the unregulated DC input (if it is available) or the regulated output of the V_{CC} regulator. The voltage divider can be set up such that the voltage at PFI falls below V_{PFI} several milliseconds before the regulated V_{CC} input to the STM70x or the micro-processor drops below the minimum operating voltage.

If the comparator is unused, \overline{PFI} should be connected to V_{SS} and \overline{PFO} left unconnected. \overline{PFO} may be connected to \overline{MR} on the STM70x so that a low voltage on PFI will generate a reset output.

3.6 Ensuring a valid reset output down to $V_{CC} = 0$ V

When V_{CC} falls below 1 V, the state of the \overline{RST} output can no longer be guaranteed, and becomes essentially an open circuit. If a high value pulldown resistor is added to the \overline{RST} pin, the output will be held low during this condition. A resistor value of approximately 100 k Ω will be large enough to not load the output under operating conditions, but still sufficient to pull \overline{RST} to ground during this low voltage condition (see [Figure 10](#)).

Figure 10. Reset output valid to ground circuit

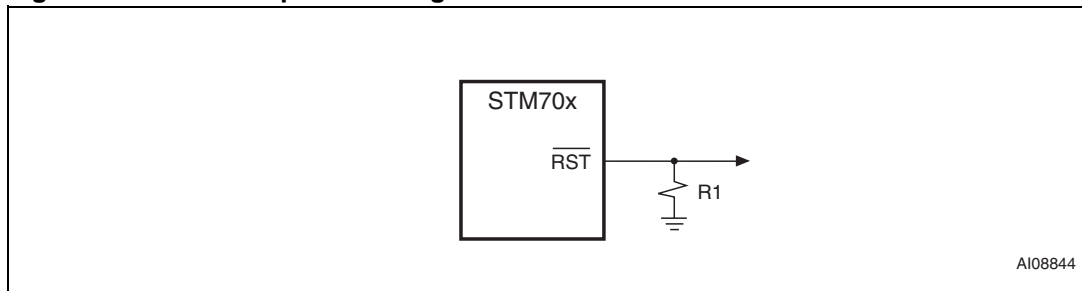

3.7 Interfacing to microprocessors with bi-directional reset pins

Microprocessors with bi-directional reset pins can contend with the STM70x reset output. For example, if the reset output is driven high and the micro wants to pull it low, signal contention will result. To prevent this from occurring, connect a 4.7kΩ resistor between the reset output and the micro's reset I/O as in [Figure 11](#).

Figure 11. Interfacing to microprocessors with bi-directional reset I/O

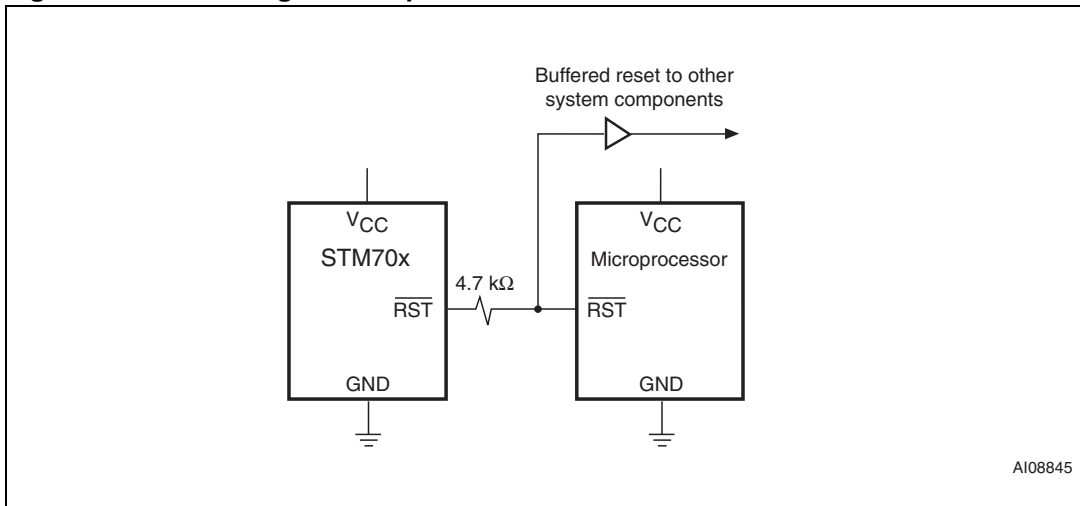

4 Typical operating characteristics

Typical values are at $T_A = 25\text{ }^\circ\text{C}$.

Figure 12. Supply current vs. temperature (no load)

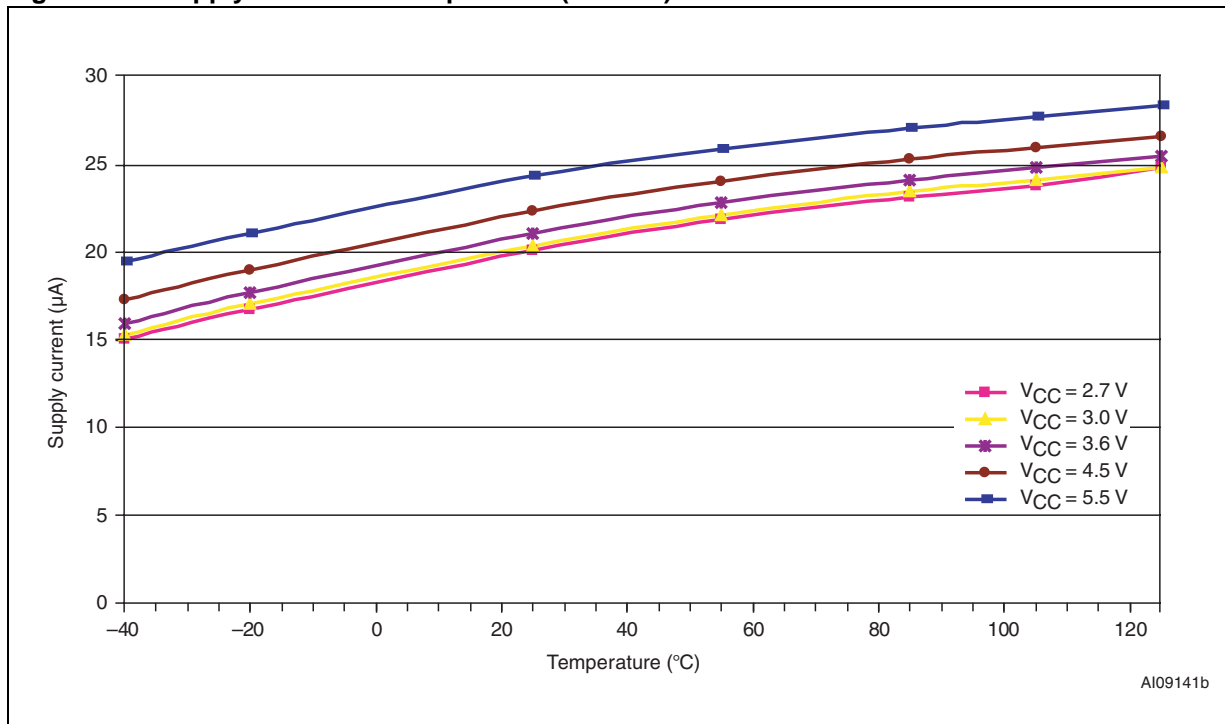

Figure 13. V_{PFI} threshold vs. temperature

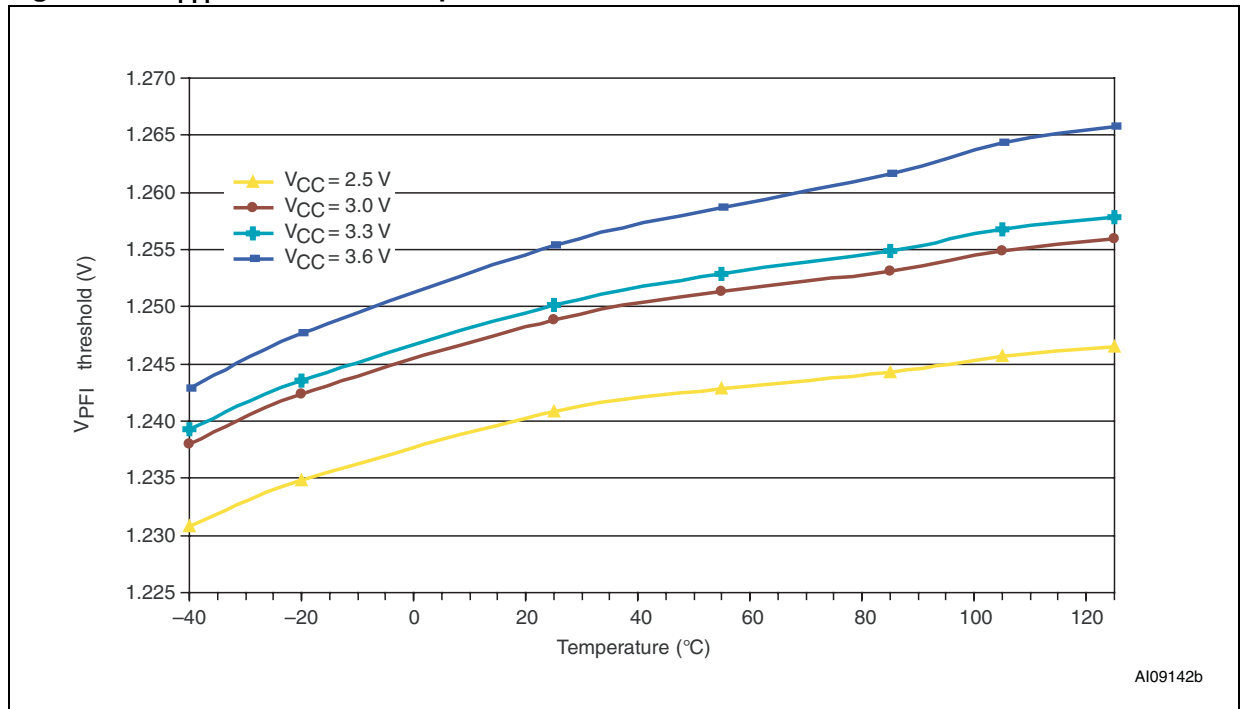

Figure 14. Reset comparator propagation delay vs. temperature

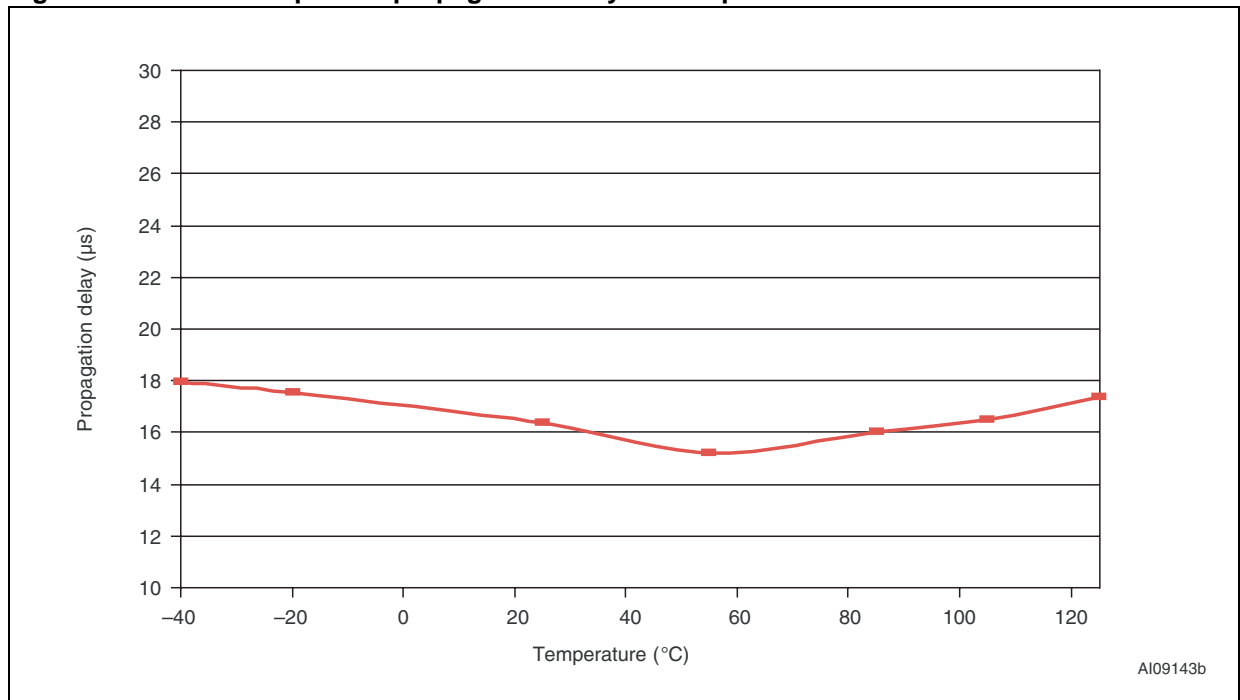

Figure 15. Power-up t_{rec} vs. temperature

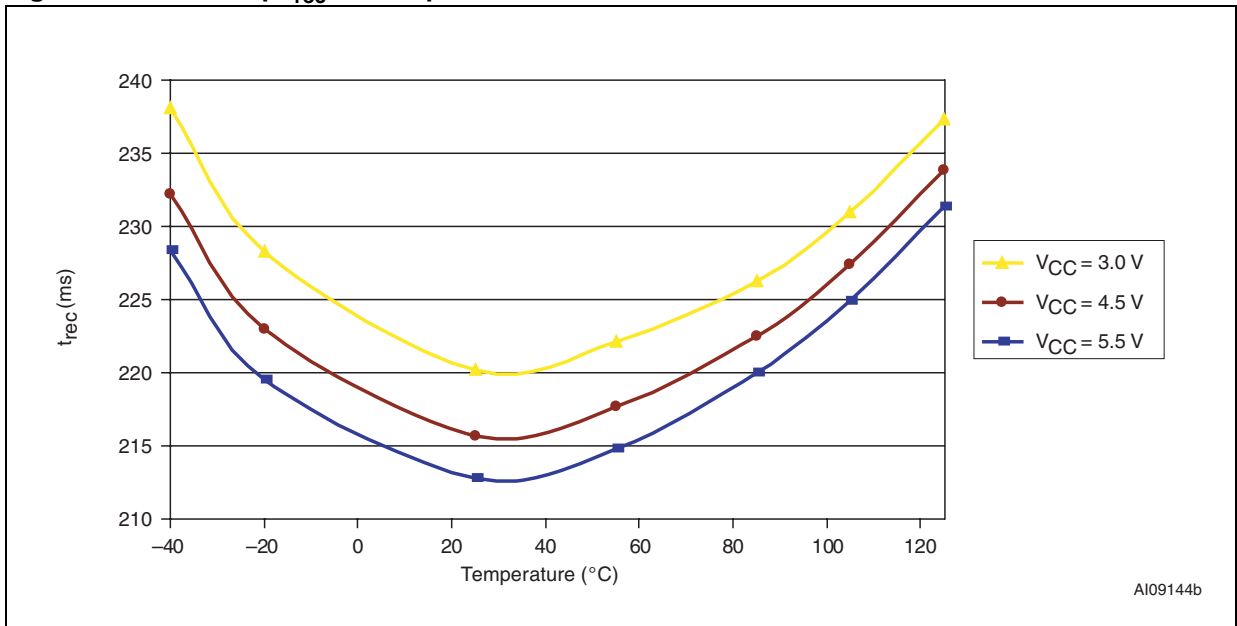

Figure 16. Normalized reset threshold vs. temperature

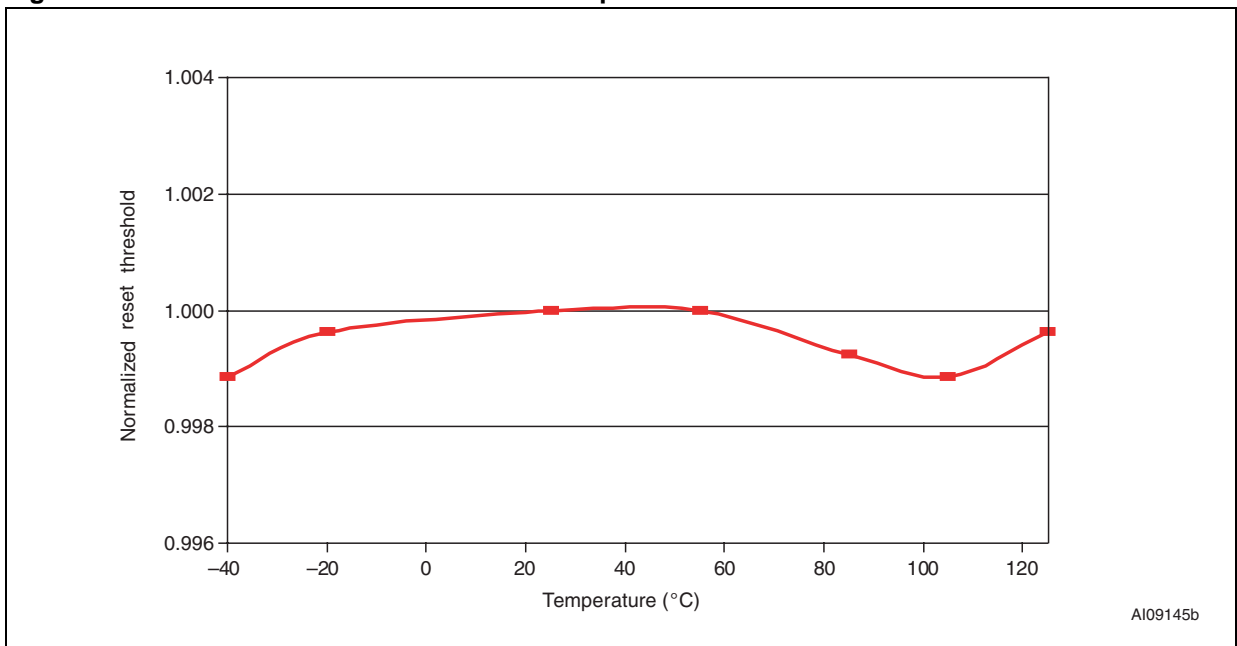
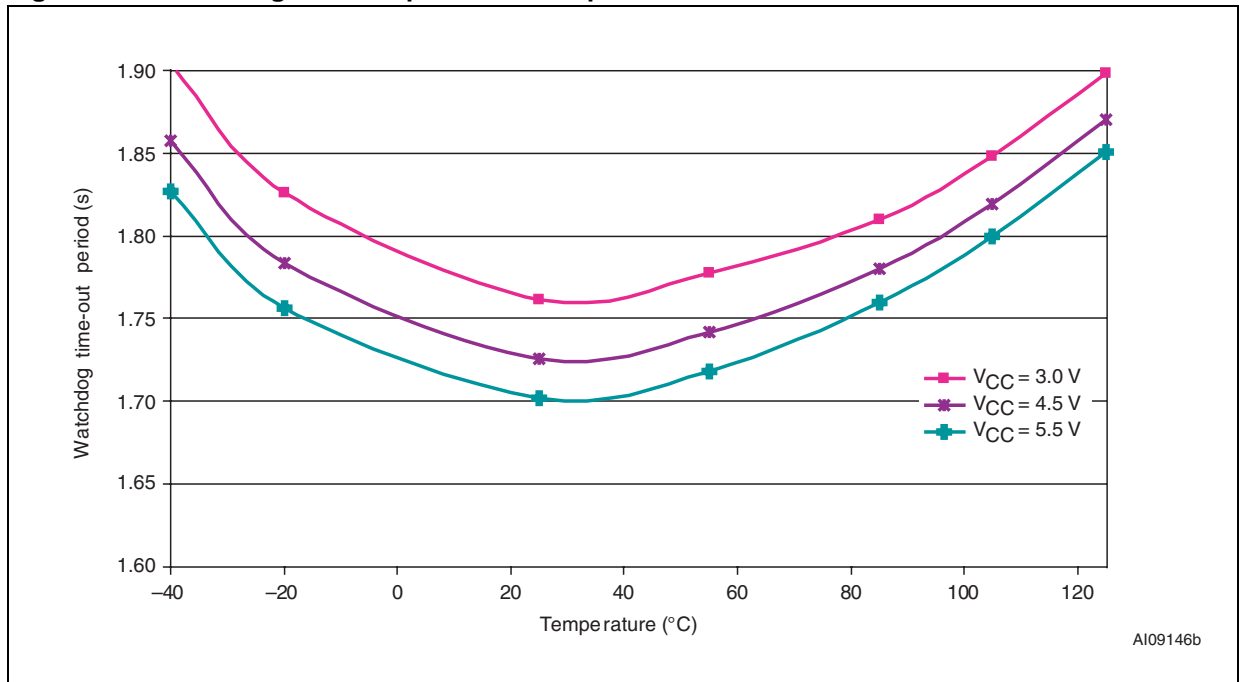
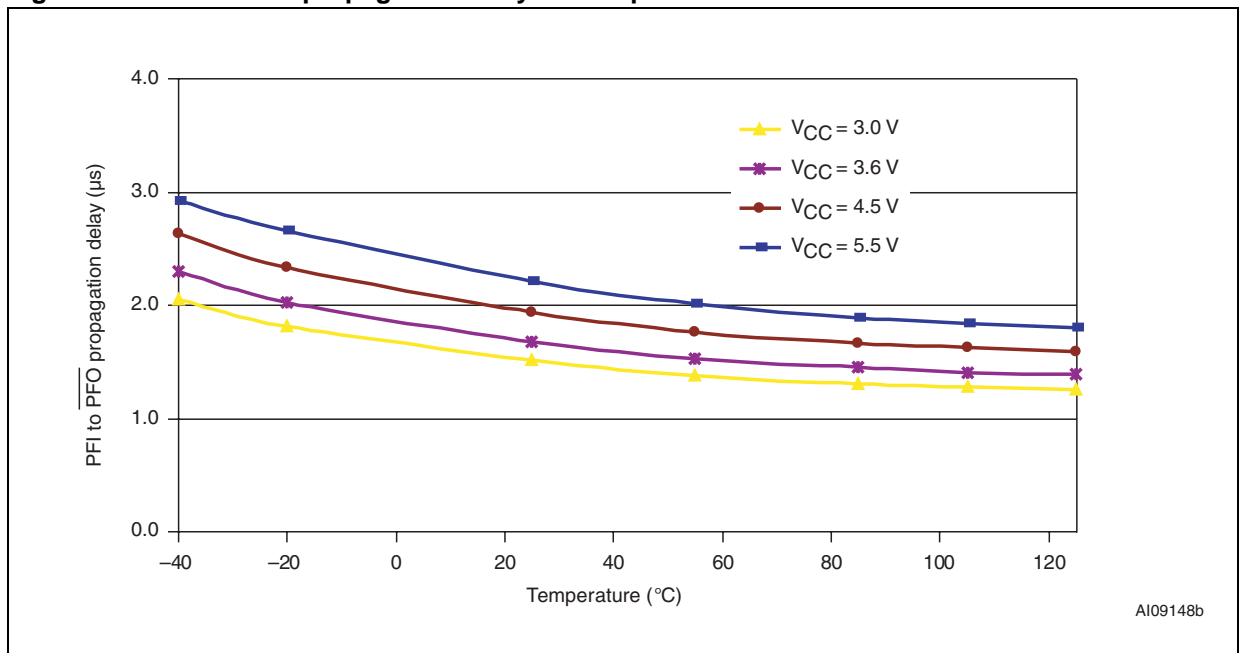

Figure 17. Watchdog time-out period vs. temperature



AI09146b

Figure 18. PFI to $\overline{\text{PFO}}$ propagation delay vs. temperature



AI09148b

Figure 19. Output voltage vs. load current ($V_{CC} = 5\text{ V}$; $V_{BAT} = 2.8\text{ V}$; $T_A = 25\text{ }^\circ\text{C}$)

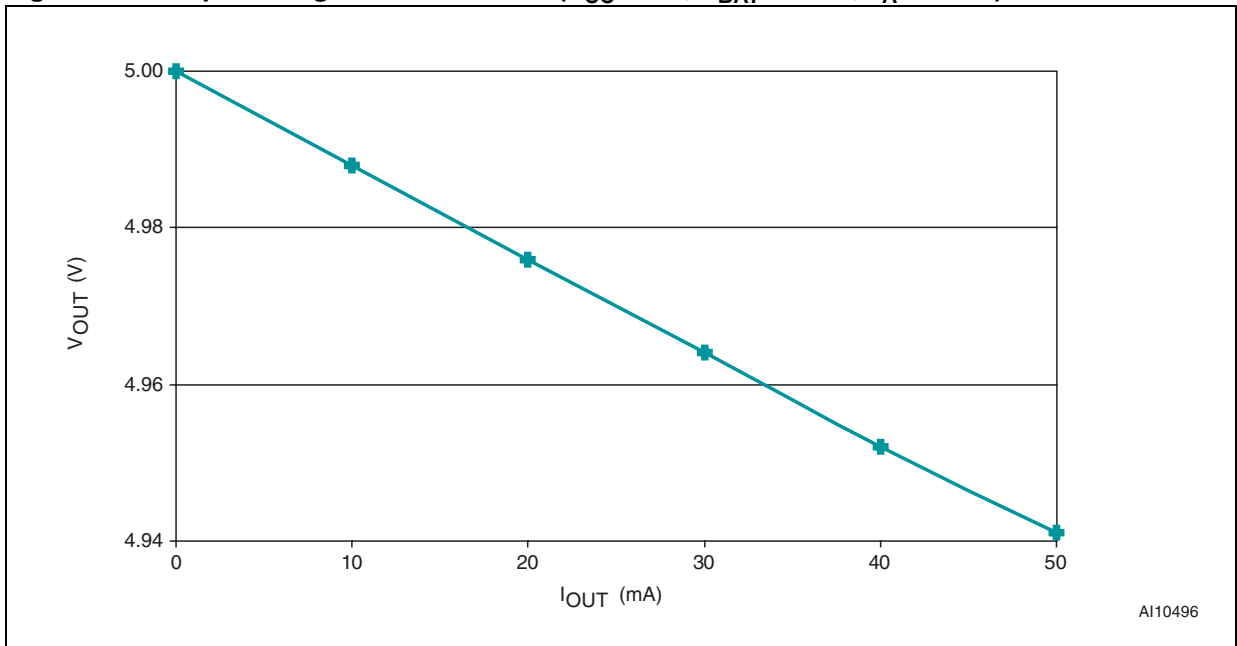

Figure 20. Output voltage vs. load current ($V_{CC} = 0\text{ V}$; $V_{BAT} = 2.8\text{ V}$; $T_A = 25\text{ }^\circ\text{C}$)

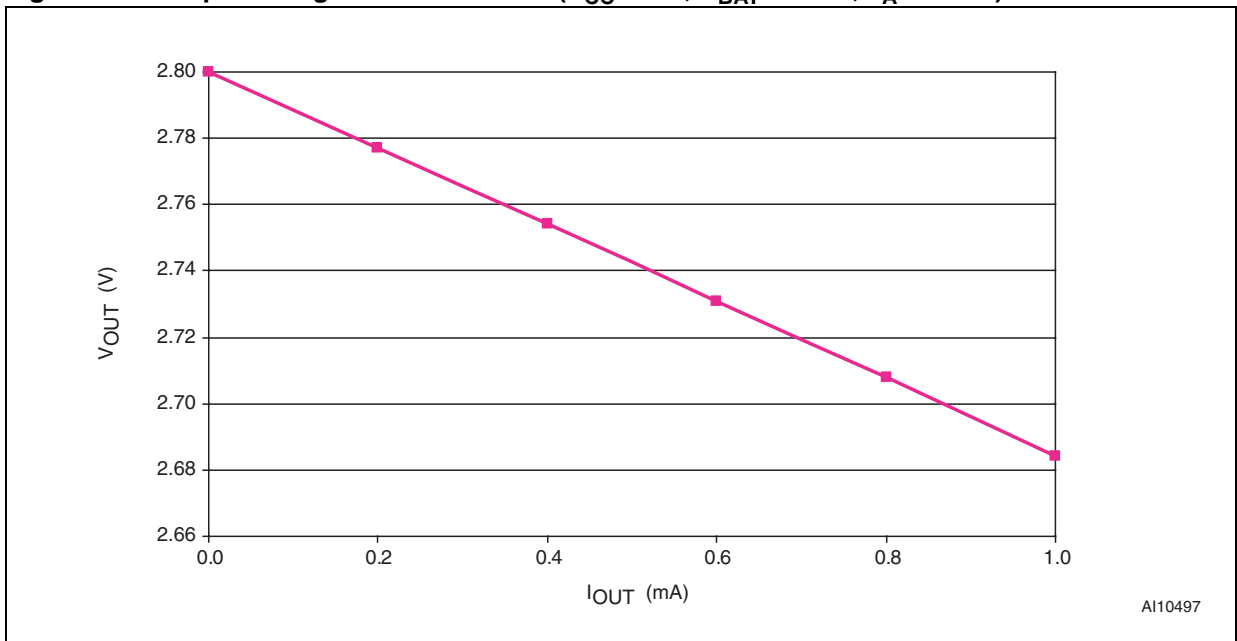

Figure 21. $\overline{\text{RST}}$ output voltage vs. supply voltage

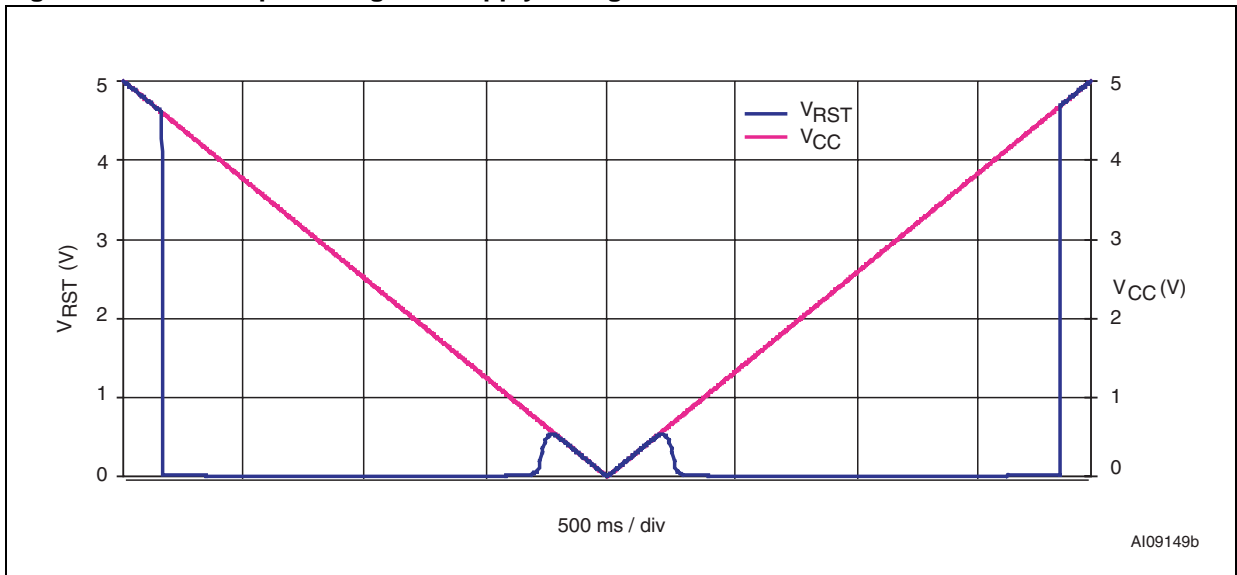

Figure 22. RST output voltage vs. supply voltage

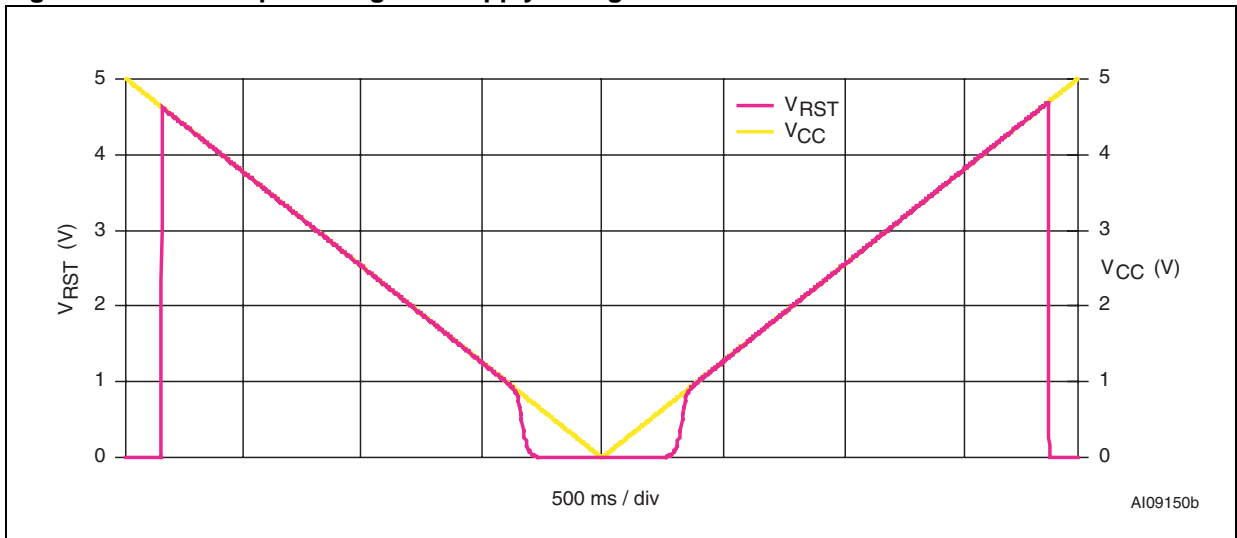

Figure 23. Power-fail comparator response time (assertion)

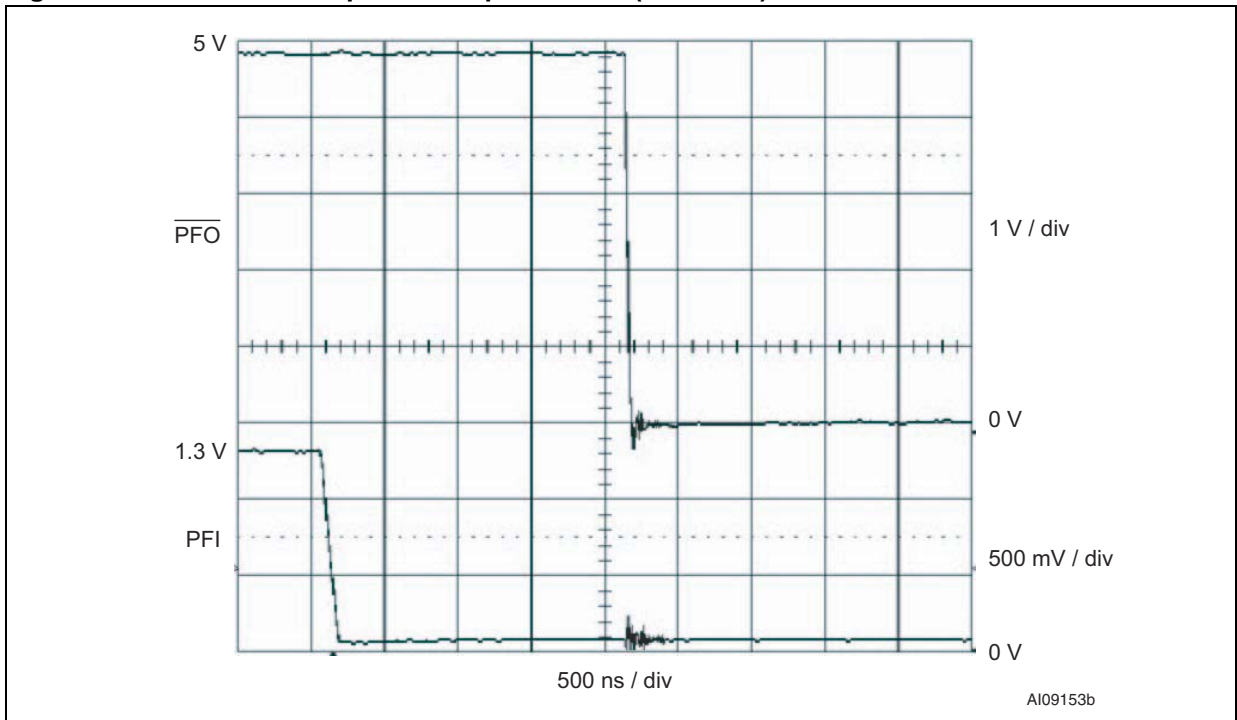

Figure 24. Power-fail comparator response time (de-assertion)

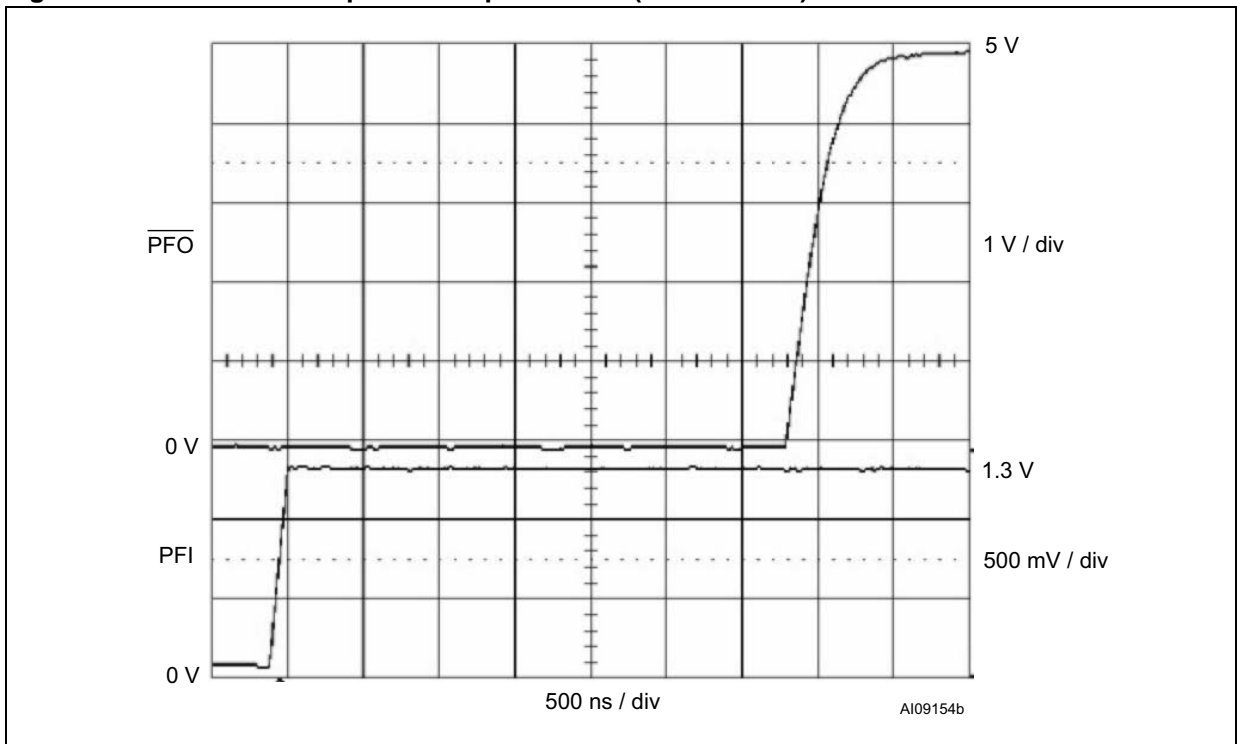
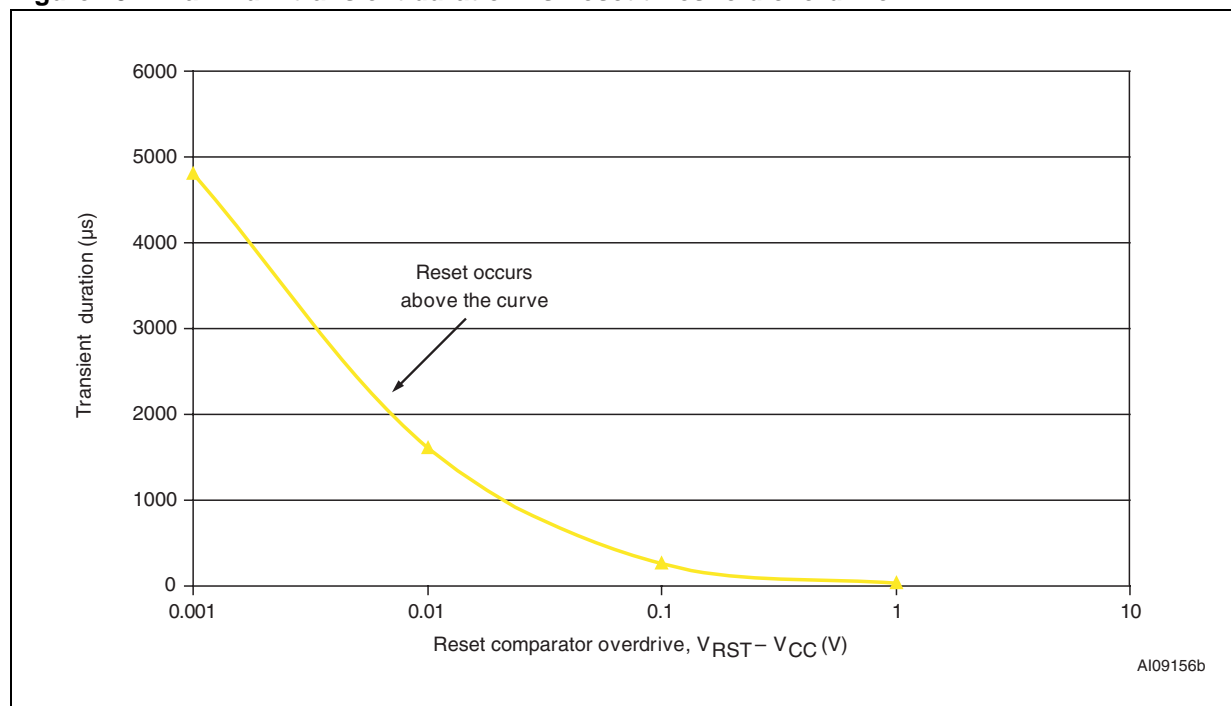

Figure 25. Maximum transient duration vs. reset threshold overdrive



5 Maximum ratings

Stressing the device above the rating listed in the "absolute maximum ratings" table may cause permanent damage to the device. These are stress ratings only and operation of the device at these or any other conditions above those indicated in the operating sections of this specification is not implied. Exposure to absolute maximum rating conditions for extended periods may affect device reliability. Refer also to the STMicroelectronics SURE Program and other relevant quality documents.

Table 4. Absolute maximum ratings

Symbol	Parameter	Value	Unit
T_{STG}	Storage temperature (V_{CC} Off)	-55 to 150	°C
$T_{SLD}^{(1)}$	Lead solder temperature for 10 seconds	260	°C
V_{IO}	Input or output voltage	-0.3 to $V_{CC} + 0.3$	V
V_{CC}	Supply voltage	-0.3 to 7.0	V
I_O	Output current	20	mA
P_D	Power dissipation	320	mW

1. Reflow at peak temperature of 260 °C. The time above 255 °C must not exceed 30 seconds.

6 DC and AC parameters

This section summarizes the operating measurement conditions, and the DC and AC characteristics of the device. The parameters in the DC and AC characteristics tables that follow, are derived from tests performed under the measurement conditions summarized in [Table 5](#), operating and AC measurement conditions. Designers should check that the operating conditions in their circuit match the operating conditions when relying on the quoted parameters.

Table 5. Operating and AC measurement conditions

Parameter	STM70x	Unit
V _{CC} supply voltage	1.0 to 5.5	V
Ambient operating temperature (T _A)	-40 to 85	°C
Input rise and fall times	≤ 5	ns
Input pulse voltages	0.2 to 0.8 V _{CC}	V
Input and output timing ref. voltages	0.3 to 0.7 V _{CC}	V

Figure 26. AC testing input/output waveforms

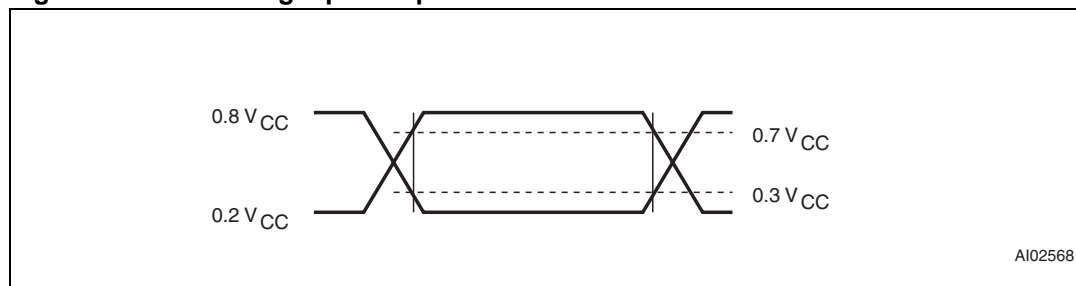

Figure 27. Power-fail comparator waveform

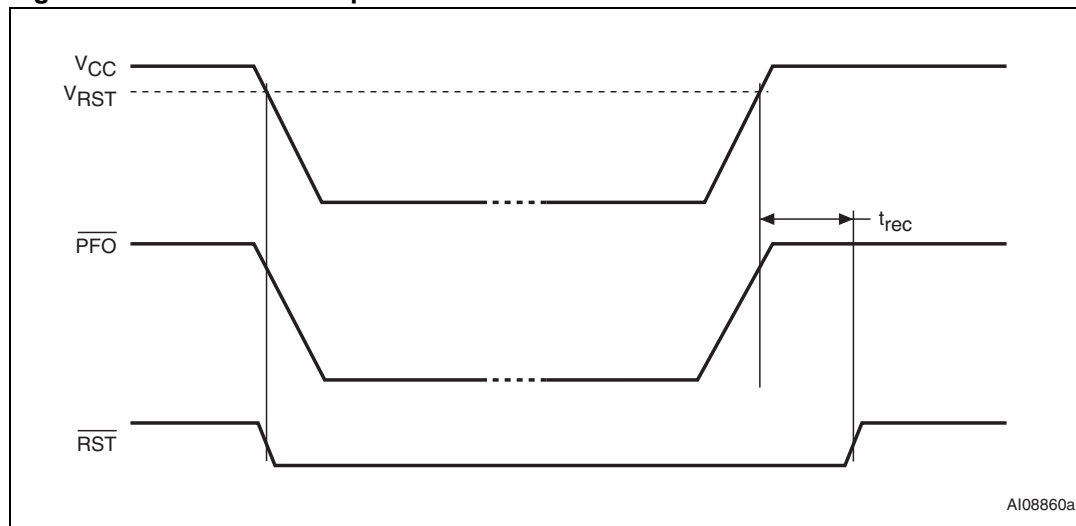
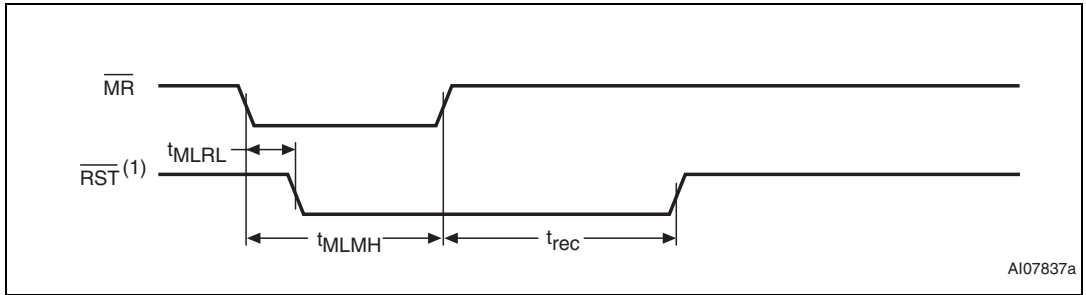

Figure 28. $\overline{\text{MR}}$ timing waveform



1. RST for STM706P and STM708T/S/R.

Figure 29. Watchdog timing (STM706T/S/R and STM706P)

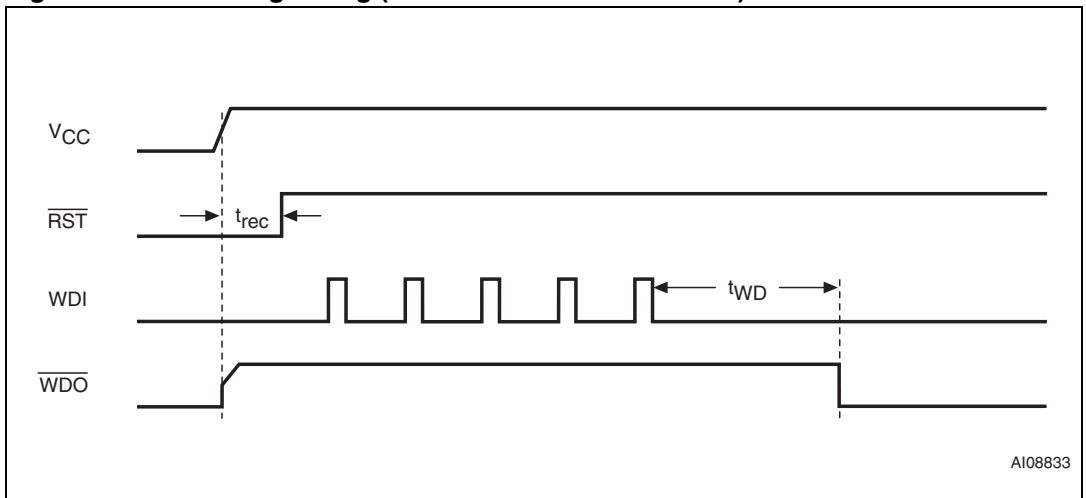

Table 6. DC and AC characteristics

Sym	Description	Test condition ⁽¹⁾	Min	Typ	Max	Unit
V _{CC}	Operating voltage		1.2 ⁽²⁾		5.5	V
I _{CC}	V _{CC} supply current	V _{CC} < 3.6 V		35	50	μA
		V _{CC} < 5.5 V		40	60	μA
I _{LI}	Input leakage current (WDI)	0 V < V _{IN} < V _{CC}	-1		+1	μA
	Input leakage current (PFI)	0 V < V _{IN} < V _{CC}	-25	2	+25	nA
	Input leakage current ($\overline{\text{MR}}$)	V _{RST} (max) < V _{CC} < 3.6 V	25	80	250	μA
4.5 V < V _{CC} < 5.5 V		75	125	300	μA	
V _{IH}	Input high voltage ($\overline{\text{MR}}$)	4.5 V < V _{CC} < 5.5 V	2.0			V
		V _{RST} (max) < V _{CC} < 3.6 V	0.7 V _{CC}			V
V _{IH}	Input high voltage (WDI)	V _{RST} (max) < V _{CC} < 5.5 V	0.7 V _{CC}			V
V _{IL}	Input low voltage ($\overline{\text{MR}}$)	4.5 V < V _{CC} < 5.5 V			0.8	V
		V _{RST} (max) < V _{CC} < 3.6 V			0.6	V
V _{IL}	Input low voltage (WDI)	V _{RST} (max) < V _{CC} < 5.5 V			0.3 V _{CC}	V
V _{OL}	Output low voltage ($\overline{\text{PFO}}$, RST, WDO)	V _{CC} = V _{RST} (max), I _{SINK} = 3.2 mA			0.3	V
V _{OL}	Output low voltage ($\overline{\text{RST}}$)	I _{SINK} = 50 μA, V _{CC} = 1.0 V, T _A = 0 °C to 85 °C			0.3	V
		I _{SINK} = 100 μA, V _{CC} = 1.2 V			0.3	V
V _{OH}	Output high voltage ($\overline{\text{RST}}$, RST, WDO)	I _{SOURCE} = 1 mA, V _{CC} = V _{RST} (max)	2.4			V
	Output high voltage (PFO)	I _{SOURCE} = 75 μA, V _{CC} = V _{RST} (max)	0.8 V _{CC}			V
Power-fail comparator						
V _{PFI}	PFI input threshold	PFI falling (STM70xP/R, V _{CC} = 3.0 V; STM70xS/T, V _{CC} = 3.3 V)	1.20	1.25	1.30	V
t _{PFDD}	PFI to $\overline{\text{PFO}}$ propagation delay			2		μs

Table 6. DC and AC characteristics (continued)

Sym	Description	Test condition ⁽¹⁾	Min	Typ	Max	Unit
Reset thresholds						
V_{RST}	Reset threshold ⁽³⁾	STM706P/70xR	2.55	2.63	2.70	V
		STM70xS	2.85	2.93	3.00	V
		STM70xT	3.00	3.08	3.15	V
	Reset threshold hysteresis			20		mV
t_{rec}	\overline{RST} pulse width	Blank (see Table 9)	140	200	280	ms
		A ⁽⁴⁾ (see Table 9)	160	200	280	
Push-button reset input						
t_{MLMH} (or t_{MR})	\overline{MR} pulse width	$V_{RST}(\max) < V_{CC} < 3.6\text{ V}$	500			ns
		$4.5\text{ V} < V_{CC} < 5.5\text{ V}$	150			ns
t_{MLRL} (or t_{MRD})	\overline{MR} to \overline{RST} output delay	$V_{RST}(\max) < V_{CC} < 3.6\text{ V}$			750	ns
		$4.5\text{ V} < V_{CC} < 5.5\text{ V}$			250	ns
Watchdog timer (STM706T/S/R and STM706P)						
t_{WD}	Watchdog timeout period	STM706P/70xR, $V_{CC} = 3.0\text{ V}$	1.12	1.60	2.24	s
		STM70xS/70XT, $V_{CC} = 3.3\text{ V}$				
	WDI pulse width	$4.5\text{ V} < V_{CC} < 5.5\text{ V}$	50			ns
		$V_{RST}(\max) < V_{CC} < 3.6\text{ V}$	100			ns

1. Valid for ambient operating temperature: $T_A = -40$ to $85\text{ }^\circ\text{C}$; $V_{CC} = V_{RST}(\max)$ to 5.5 V (except where noted).

2. $V_{CC}(\min) = 1.0\text{ V}$ for $T_A = 0\text{ }^\circ\text{C}$ to $+85\text{ }^\circ\text{C}$.

3. For V_{CC} falling.

4. STM706P/STM70xR, $V_{CC} = 3\text{ V}$; STM706xS/STM70xT, $V_{CC} = 3.3\text{ V}$.

7 Package mechanical data

In order to meet environmental requirements, ST offers these devices in different grades of ECOPACK[®] packages, depending on their level of environmental compliance. ECOPACK[®] specifications, grade definitions and product status are available at: www.st.com. ECOPACK[®] is an ST trademark.

Figure 30. SO8 – 8-lead plastic small outline, 150 mils body width, package mechanical

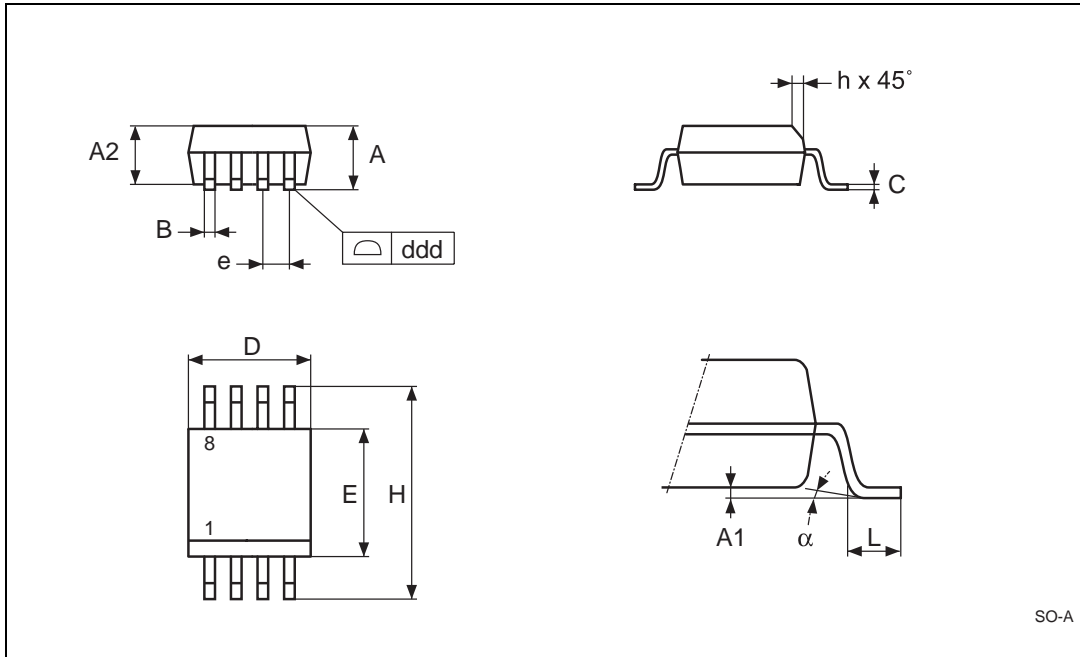

Note: Drawing is not to scale.

Table 7. SO8 - 8-lead plastic small outline, 150 mils body width, package mechanical data

Symb	mm			inches		
	Typ	Min	Max	Typ	Min	Max
A	—	1.35	1.75	—	0.053	0.069
A1	—	0.10	0.25	—	0.004	0.010
B	—	0.33	0.51	—	0.013	0.020
C	—	0.19	0.25	—	0.007	0.010
D	—	4.80	5.00	—	0.189	0.197
ddd	—	—	0.10	—	—	0.004
E	—	3.80	4.00	—	0.150	0.157
e	1.27	—	—	0.050	—	—
H	—	5.80	6.20	—	0.228	0.244
h	—	0.25	0.50	—	0.010	0.020
L	—	0.40	0.90	—	0.016	0.035
alpha	—	0°	8°	—	0°	8°
N	8	8				

Figure 31. TSSOP8 – 8-lead, thin shrink small outline, 3 x 3 mm body size, outline

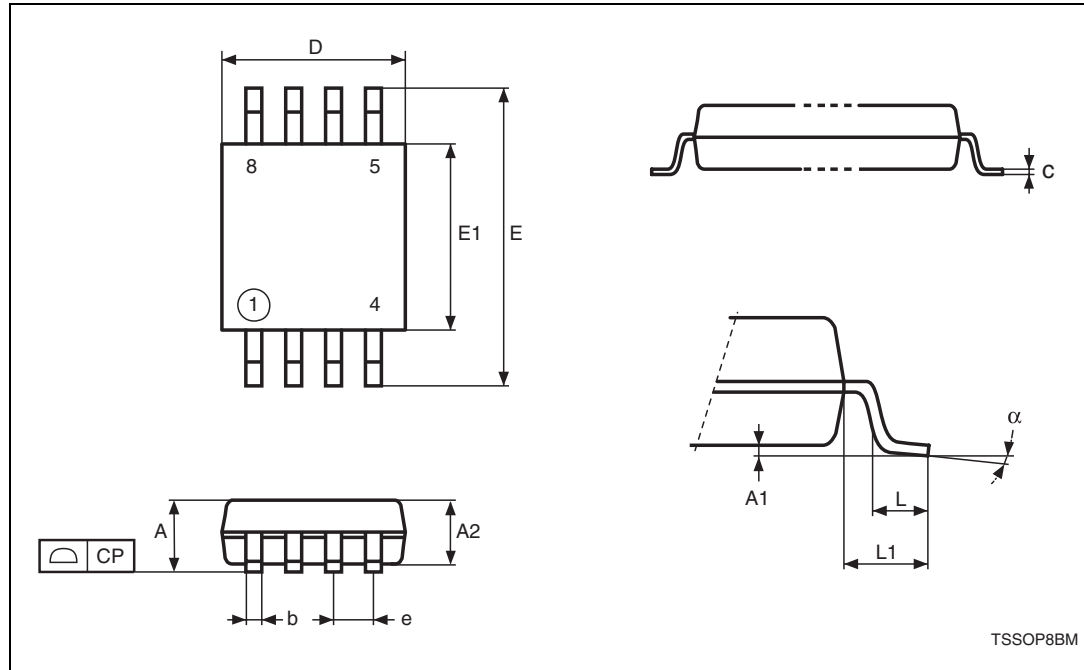

Note: Drawing is not to scale.

Table 8. TSSOP8 - 8-lead, thin shrink small outline, 3 x 3 mm body size, mechanical data

Symb	mm			inches		
	Typ	Min	Max	Typ	Min	Max
A	—	—	1.10	—	—	0.043
A1	—	0.05	0.15	—	0.002	0.006
A2	0.85	0.75	0.95	0.034	0.030	0.037
b	—	0.25	0.40	—	0.010	0.016
c	—	0.13	0.23	—	0.005	0.009
CP	—	—	0.10	—	—	0.004
D	3.00	2.90	3.10	0.118	0.114	0.122
e	0.65	—	—	0.026	—	—
E	4.90	4.65	5.15	0.193	0.183	0.203
E1	3.00	2.90	3.10	0.118	0.114	0.122
L	0.55	0.40	0.70	0.022	0.016	0.030
L1	0.95	—	—	0.037	—	—
alpha	—	0°	6°	—	0°	6°
N	8	8				

8 Part numbering

Table 9. Ordering information scheme

Example:	STM706	T	M	6	E
Device type	STM706 STM708				
Reset threshold voltage	T: $3.00\text{ V} \leq V_{\text{RST}} \leq 3.15\text{ V}$ S: $2.88\text{ V} \leq V_{\text{RST}} \leq 3.00\text{ V}$ R, STM706P: $2.59\text{ V} \leq V_{\text{RST}} \leq 2.70\text{ V}$				
RST pulse width	Blank = 140 to 280 ms A ⁽¹⁾ = 160 to 280 ms				
Package	M = SO8 DS = TSSOP8				
Temperature range	6 = -40 to 85 °C				
Shipping method	E = ECOPACK [®] packages, tubes F = ECOPACK [®] packages, tape and reel				
	1. Available in SO8 (M) package only				

For other options, or for more information on any aspect of this device, please contact the ST sales office nearest you.

Table 10. Marking description

Part number	Reset threshold	Package	Topside marking
STM706P	2.63 V	SO8	706P
		TSSOP8	
STM706T	3.08 V	SO8	706T
		TSSOP8	
STM706S	2.93 V	SO8	706S
		TSSOP8	
STM706R	2.63 V	SO8	706R
		TSSOP8	
STM708T	3.08 V	SO8	708T
		TSSOP8	
STM708S	2.93 V	SO8	708S
		TSSOP8	
STM708R	2.63 V	SO8	708R
		TSSOP8	

9 Revision history

Table 11. Document revision history

Date	Revision	Changes
Oct-2003	1	Initial release.
12-Dec-2003	2	Reformatted; update characteristics (Figure 2, 3, 8 to 10, 28 to 30; Table 6 to 9).
16-Jan-2004	2.1	Add <i>Typical operating characteristics</i> (Figure 13, to 19, 22, to 26).
09-Apr-2004	3	Reformatted; update characteristics (Figure 15, 19, 22, 23, 26; Table 8).
25-May-2004	4	Update characteristics (Table 3, Table 6).
02-Jul-2004	5	Datasheet promoted; waveform corrected (Table 28).
21-Sep-2004	6	Clarify root part numbers; (Figure 2, to 10, 30; Table 1, 3, 6, 9).
25-Feb-2005	7	Update typical characteristics (Figure 13 to 26).
02-Nov-2009	8	Updated Table 1, Table 3, Table 4, Table 6, Table 9, Section 2.3, Section 2.7 , text in Section 7 ; reformatted document.

Please Read Carefully:

Information in this document is provided solely in connection with ST products. STMicroelectronics NV and its subsidiaries ("ST") reserve the right to make changes, corrections, modifications or improvements, to this document, and the products and services described herein at any time, without notice.

All ST products are sold pursuant to ST's terms and conditions of sale.

Purchasers are solely responsible for the choice, selection and use of the ST products and services described herein, and ST assumes no liability whatsoever relating to the choice, selection or use of the ST products and services described herein.

No license, express or implied, by estoppel or otherwise, to any intellectual property rights is granted under this document. If any part of this document refers to any third party products or services it shall not be deemed a license grant by ST for the use of such third party products or services, or any intellectual property contained therein or considered as a warranty covering the use in any manner whatsoever of such third party products or services or any intellectual property contained therein.

UNLESS OTHERWISE SET FORTH IN ST'S TERMS AND CONDITIONS OF SALE ST DISCLAIMS ANY EXPRESS OR IMPLIED WARRANTY WITH RESPECT TO THE USE AND/OR SALE OF ST PRODUCTS INCLUDING WITHOUT LIMITATION IMPLIED WARRANTIES OF MERCHANTABILITY, FITNESS FOR A PARTICULAR PURPOSE (AND THEIR EQUIVALENTS UNDER THE LAWS OF ANY JURISDICTION), OR INFRINGEMENT OF ANY PATENT, COPYRIGHT OR OTHER INTELLECTUAL PROPERTY RIGHT.

UNLESS EXPRESSLY APPROVED IN WRITING BY AN AUTHORIZED ST REPRESENTATIVE, ST PRODUCTS ARE NOT RECOMMENDED, AUTHORIZED OR WARRANTED FOR USE IN MILITARY, AIR CRAFT, SPACE, LIFE SAVING, OR LIFE SUSTAINING APPLICATIONS, NOR IN PRODUCTS OR SYSTEMS WHERE FAILURE OR MALFUNCTION MAY RESULT IN PERSONAL INJURY, DEATH, OR SEVERE PROPERTY OR ENVIRONMENTAL DAMAGE. ST PRODUCTS WHICH ARE NOT SPECIFIED AS "AUTOMOTIVE GRADE" MAY ONLY BE USED IN AUTOMOTIVE APPLICATIONS AT USER'S OWN RISK.

Resale of ST products with provisions different from the statements and/or technical features set forth in this document shall immediately void any warranty granted by ST for the ST product or service described herein and shall not create or extend in any manner whatsoever, any liability of ST.

ST and the ST logo are trademarks or registered trademarks of ST in various countries.

Information in this document supersedes and replaces all information previously supplied.

The ST logo is a registered trademark of STMicroelectronics. All other names are the property of their respective owners.

© 2009 STMicroelectronics - All rights reserved

STMicroelectronics group of companies

Australia - Belgium - Brazil - Canada - China - Czech Republic - Finland - France - Germany - Hong Kong - India - Israel - Italy - Japan - Malaysia - Malta - Morocco - Philippines - Singapore - Spain - Sweden - Switzerland - United Kingdom - United States of America

www.st.com

