

## LF156QML JFET Input Operational Amplifiers

Check for Samples: [LF156QML](#)

### FEATURES

- **Advantages**
  - Replace Expensive Hybrid and Module FET Op Amps
  - Rugged JFETs Allow Blow-Out Free Handling Compared with MOSFET Input Devices
  - Excellent for Low Noise Applications Using Either High or Low Source Impedance—Very Low 1/f Corner
  - Offset Adjust Does Not Degrade Drift or Common-Mode Rejection as in Most Monolithic Amplifiers
  - New Output Stage Allows Use of Large Capacitive Loads (5,000 pF) Without Stability Problems
  - Internal Compensation and Large Differential Input Voltage Capability

### APPLICATIONS

- Precision High Speed Integrators
- Fast D/A and A/D Converters
- High Impedance Buffers
- Wideband, Low Noise, Low Drift Amplifiers
- Logarithmic Amplifiers
- Photocell Amplifiers
- Sample and Hold Circuits

### Connection Diagrams

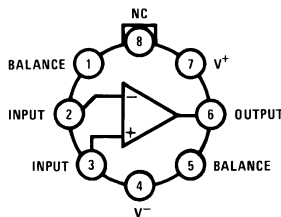

**Figure 1. Top View  
TO-99 Package (LMC)  
See Package Number LMC**

### COMMON FEATURES

- Low Input Bias Current: 30pA
- Low Input Offset Current: 3pA
- High Input Impedance:  $10^{12}\Omega$
- Low Input Noise Current:  $0.01 \text{ pA} / \sqrt{\text{Hz}}$
- High Common-Mode Rejection Ratio: 100 dB
- Large DC Voltage Gain: 106 dB

### UNCOMMON FEATURES

- Extremely Fast Settling
  - Time to 0.01% 1.5 $\mu$ s
- Fast Slew Rate 12V/ $\mu$ s
- Wide Gain Bandwidth 5MHz
- Low Input Noise Voltage  $12 \text{ nV} / \sqrt{\text{Hz}}$

### DESCRIPTION

This is the first monolithic JFET input operational amplifier to incorporate well matched, high voltage JFETs on the same chip with standard bipolar transistors (BI-FET™ Technology). This amplifier features low input bias and offset currents/low offset voltage and offset voltage drift, coupled with offset adjust which does not degrade drift or common-mode rejection. The device is also designed for high slew rate, wide bandwidth, extremely fast settling time, low voltage and current noise and a low 1/f noise corner.



Please be aware that an important notice concerning availability, standard warranty, and use in critical applications of Texas Instruments semiconductor products and disclaimers thereto appears at the end of this data sheet.

All trademarks are the property of their respective owners.

### Simplified Schematic

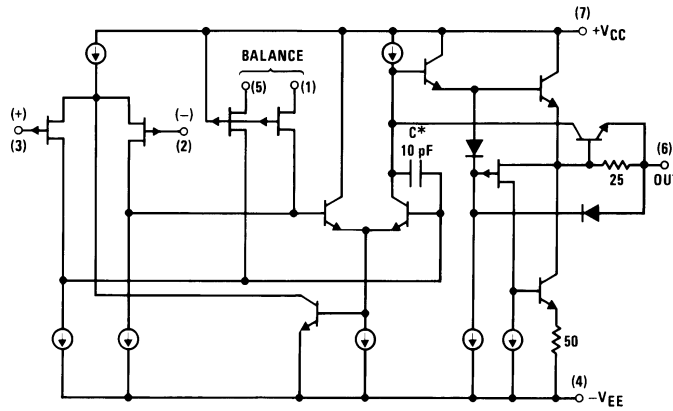

\*3pF in LF357 series.

### Detailed Schematic

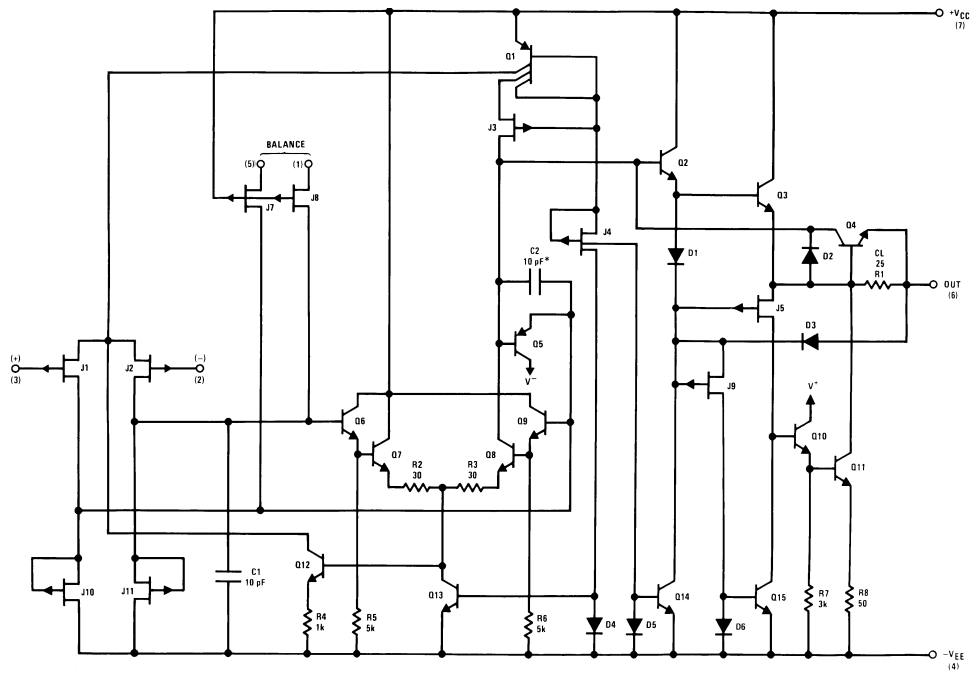

\*C = 3pF in LF357 series.



These devices have limited built-in ESD protection. The leads should be shorted together or the device placed in conductive foam during storage or handling to prevent electrostatic damage to the MOS gates.

**Absolute Maximum Ratings<sup>(1)</sup>**

Supply Voltage		±22V	
Differential Input Voltage		±40V	
Input Voltage Range <sup>(2)</sup>		±20V	
Output Short Circuit Duration		Continuous	
T <sub>Jmax</sub>		150°C	
Power Dissipation at T <sub>A</sub> = 25°C <sup>(3)(4)</sup>		Still Air	560 mW
		500 LF/Min Air Flow	1200 mW
Thermal Resistance	θ <sub>JA</sub>	Still Air	162°C/W
		400 LF/Min Air Flow	89°C/W
	θ <sub>JC</sub>		32°C/W
Storage Temperature Range		-65°C ≤ T <sub>A</sub> ≤ +150°C	
Lead Temperature (Soldering 10 sec.)		300°C	
ESD tolerance <sup>(5)</sup>		1200V	

- (1) Absolute Maximum Ratings indicate limits beyond which damage to the device may occur. Operating Ratings indicate condition for which the device is functional, but do not ensure specific performance limits. For ensured specifications and test conditions, see the Electrical Characteristics. The ensured specifications apply only for the test conditions listed. Some performance characteristics may degrade when the device is not operated under the listed test conditions.
- (2) Unless otherwise specified the absolute maximum negative input voltage is equal to the negative power supply voltage.
- (3) The maximum power dissipation must be derated at elevated temperatures and is dictated by T<sub>Jmax</sub>(maximum junction temperature), θ<sub>JA</sub>(package junction to ambient thermal resistance), and T<sub>A</sub> (ambient temperature). The maximum allowable power dissipation at any temperature is P<sub>D</sub>=(T<sub>Jmax</sub>-T<sub>A</sub>)/θ<sub>JA</sub> or the number given in the Absolute Maximum Ratings, whichever is lower.
- (4) Maximum power dissipation (P<sub>Dmax</sub>) is defined by the package characteristics. Operating the part near the P<sub>Dmax</sub> may cause the part to operate outside specified limits.
- (5) Human body model, 100pF discharged through 1.5KΩ.

**Quality Conformance Inspection**

MIL-STD-883, Method 5005 - Group A

Subgroup	Description	Temp ( C )
1	Static tests at	+25
2	Static tests at	+125
3	Static tests at	-55
4	Dynamic tests at	+25
5	Dynamic tests at	+125
6	Dynamic tests at	-55
7	Functional tests at	+25
8A	Functional tests at	+125
8B	Functional tests at	-55
9	Switching tests at	+25
10	Switching tests at	+125
11	Switching tests at	-55

### LF156 Electrical Characteristics DC Parameters

The following conditions apply, unless otherwise specified.

DC:  $V_{CC} = \pm 5V$ ,  $V_{CM} = 0V$ ,  $R_S = 50\Omega$

Symbol	Parameter	Conditions	Notes	Min	Max	Unit	Sub-groups
$V_{IO}$	Input Offset Voltage			-5.0	5.0	mV	1
				-7.0	7.0	mV	2, 3
		$V_{CC} = \pm 20V$		-5.0	5.0	mV	1
				-7.0	7.0	mV	2, 3
$I_{IO}$	Input Offset Current	$V_{CC} = \pm 20V$		-0.02	0.02	nA	1
				-20	20	nA	2, 3
$+I_{IB}$	Input Bias Current	$V_{CC} = \pm 20V$		-0.1	0.1	nA	1
				-10	50	nA	2, 3
		$V_{CC} = \pm 20V$ , $V_{CM} = -16V$		-0.1	0.1	nA	1
				-10	50	nA	2, 3
		$V_{CC} = \pm 20V$ , $V_{CM} = 16V$		-0.1	3.5	nA	1
				-10	60	nA	2, 3
$-I_{IB}$	Input Bias Current	$V_{CC} = \pm 20V$		-0.1	0.1	nA	1
				-10	50	nA	2, 3
		$V_{CC} = \pm 20V$ , $V_{CM} = -16V$		-0.1	0.1	nA	1
				-10	50	nA	2, 3
		$V_{CC} = \pm 20V$ , $V_{CM} = 16V$		-0.1	3.5	nA	1
				-10	60	nA	2, 3
$+PSRR$	Power Supply Rejection Ratio	$+V_{CC} = 20V$ to $10V$ , $-V_{CC} = -20V$		85		dB	1, 2, 3
$-PSRR$	Power Supply Rejection Ratio	$-V_{CC} = -20V$ to $-10V$ , $+V_{CC} = 20V$		85		dB	1, 2, 3
CMRR	Common Mode Rejection Ratio	$V_{CM} = \pm 11V$		85		dB	1, 2, 3
$I_{CC}$	Power Supply Current				7.0	mA	1
					14	mA	2, 3
$+I_{OS}$	Short Circuit Current	$V_O = 0V$		-45	-15	mA	1
				-35	-10	mA	2
				-65	-15	mA	3
$-I_{OS}$	Short Circuit Current	$V_O = 0V$		15	45	mA	1
				10	35	mA	2
				15	65	mA	3
$V_{CM}$	Common Mode Voltage Range		See <sup>(1)</sup>	-11	11	V	1, 2, 3
$+V_{OP}$	Output Voltage Swing	$R_L = 10K\Omega$		12		V	4, 5, 6
		$R_L = 2K\Omega$	See <sup>(1)</sup>	10		V	4, 5, 6
$-V_{OP}$	Output Voltage Swing	$R_L = 10K\Omega$			-12	V	4, 5, 6
		$R_L = 2K\Omega$	See <sup>(1)</sup>		-10	V	4, 5, 6
$A_{VS}$	Large Signal Voltage Gain	$R_L = 2K\Omega$ , $V_O = 0$ to $10V$		50		V/mV	4
				25		V/mV	5, 6
		$R_L = 2K\Omega$ , $V_O = 0$ to $-10V$		50		V/mV	4
				25		V/mV	5, 6

(1) Parameter specified by CMRR test.

## LF156 Electrical Characteristics AC Parameters

The following conditions apply, unless otherwise specified.

AC:  $V_{CC} = \pm 5V$ ,  $V_{CM} = 0V$ ,  $R_S = 50\Omega$

Symbol	Parameter	Conditions	Notes	Min	Max	Unit	Sub-groups
+SR	Slew Rate	$A_V = 1$ , $R_{LOAD} = 2K\Omega$ , $C_L = 100pfd$ , $V_I = -5V$ to $+5V$		7.5		V/ $\mu$ S	7
-SR	Slew Rate	$A_V = 1$ , $R_L = 2K\Omega$ , $C_L = 100pF$ , $V_I = +5V$ to $-5V$		7.5		V/ $\mu$ S	7

Typical DC Performance Characteristics

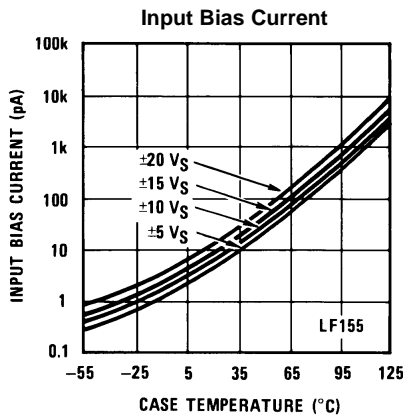

Figure 2.

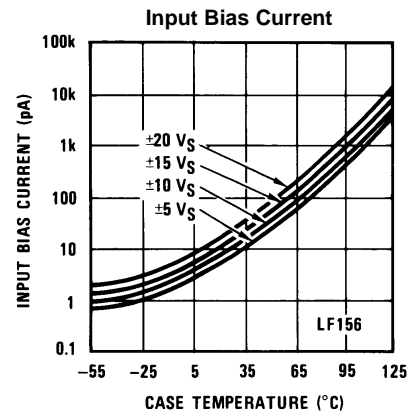

Figure 3.

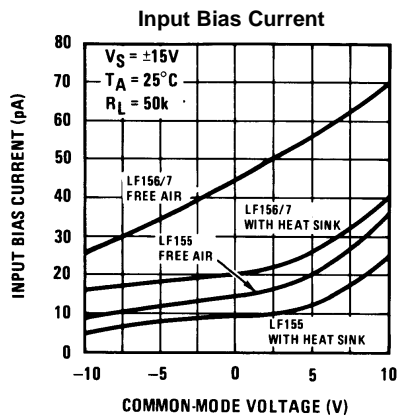

Figure 4.

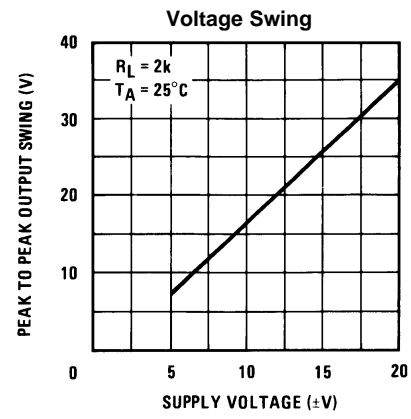

Figure 5.

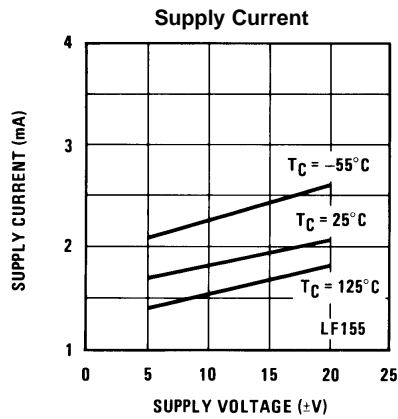

Figure 6.

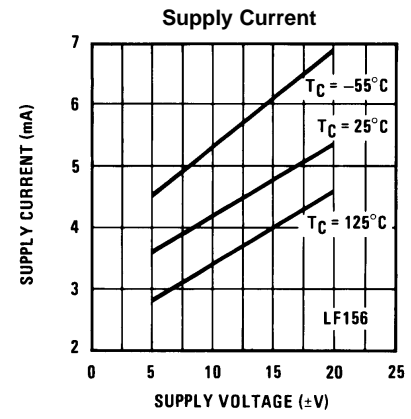

Figure 7.

Typical DC Performance Characteristics (continued)

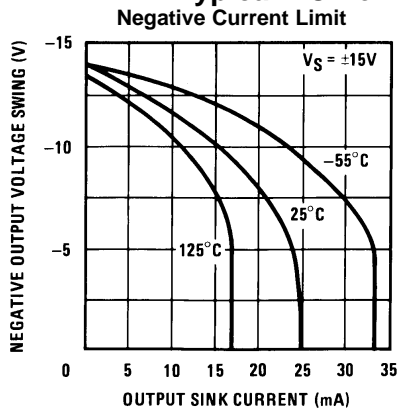

Figure 8.

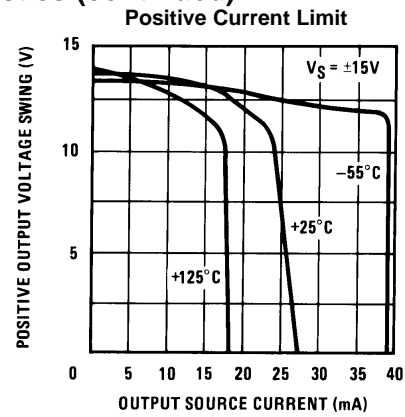

Figure 9.

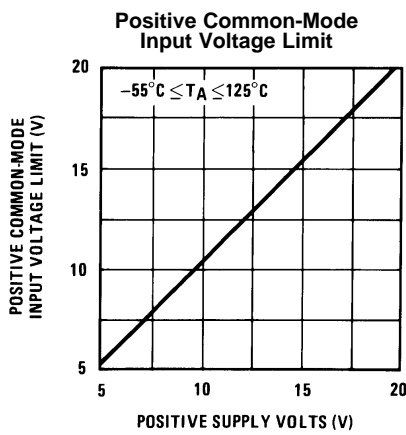

Figure 10.

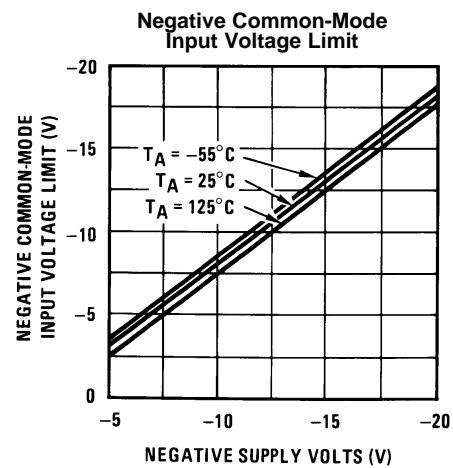

Figure 11.

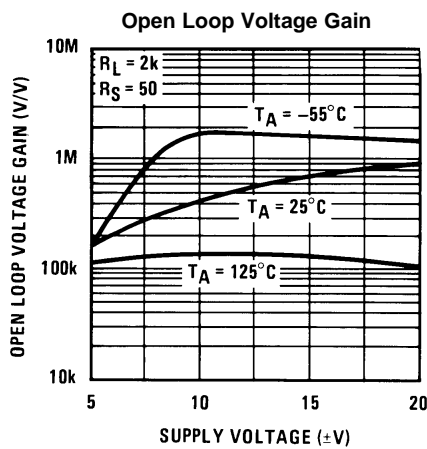

Figure 12.

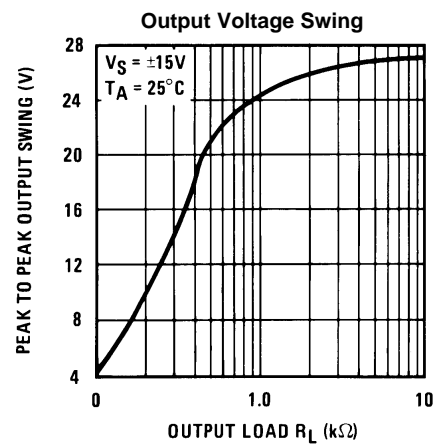

Figure 13.

Typical AC Performance Characteristics

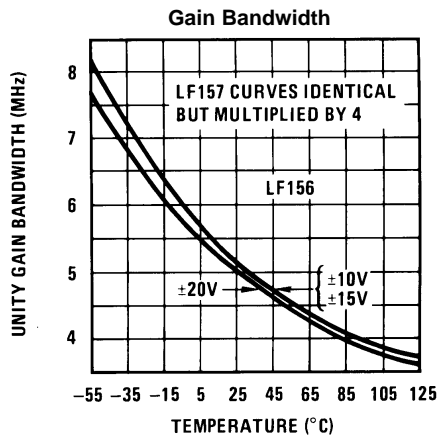

Figure 14.

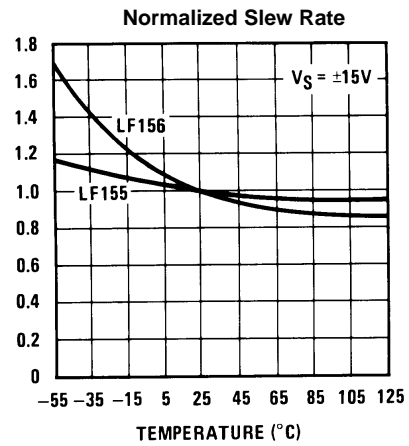

Figure 15.

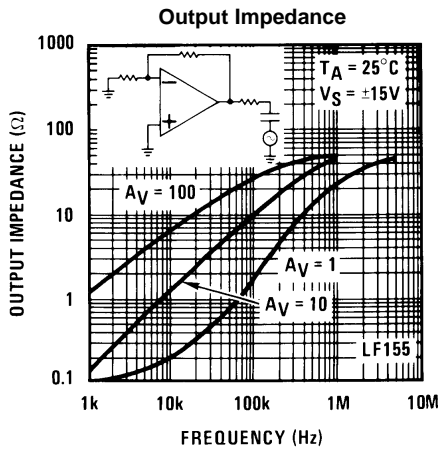

Figure 16.

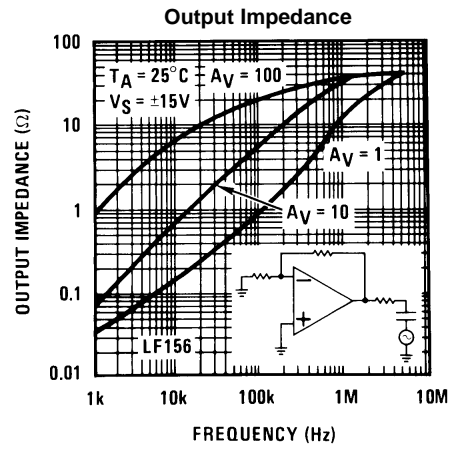

Figure 17.

LF156 Small Signal Pulse Response,  $A_V = +1$

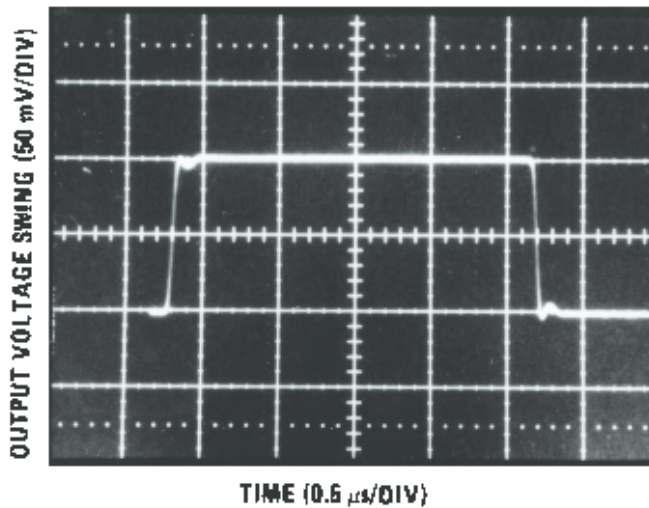

Figure .

LF156 Large Signal Puls Response,  $A_V = +1$

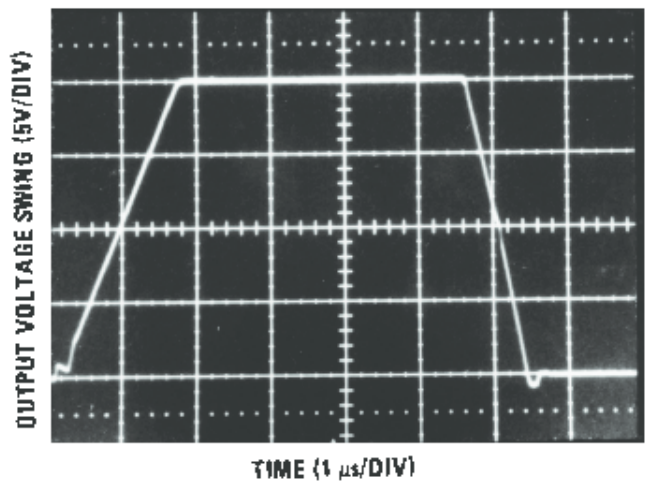

Figure 18.

Typical AC Performance Characteristics (continued)

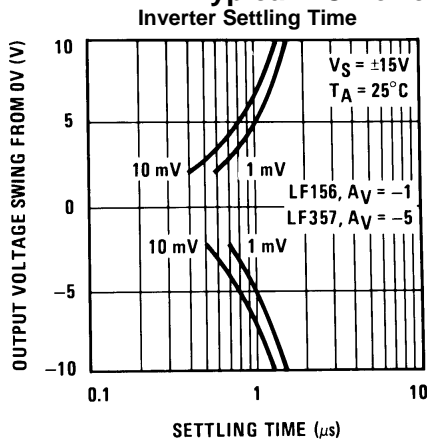

Figure 19.

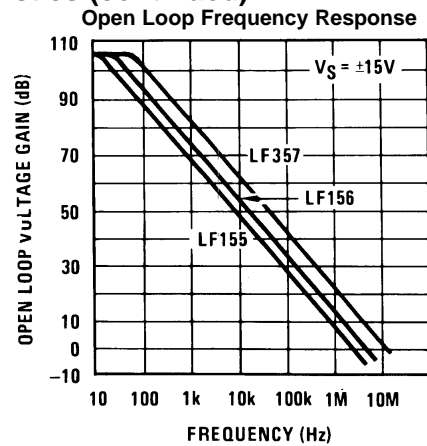

Figure 20.

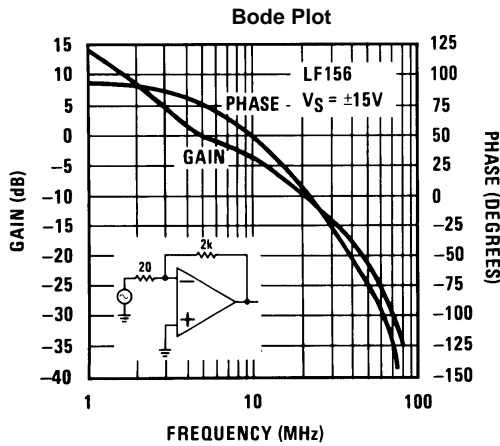

Figure .

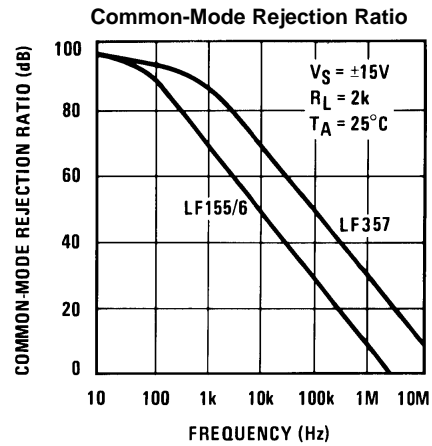

Figure 21.

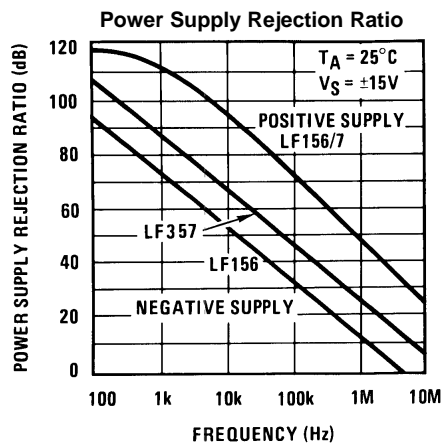

Figure 22.

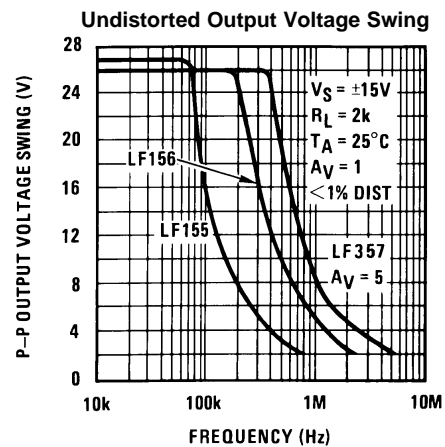
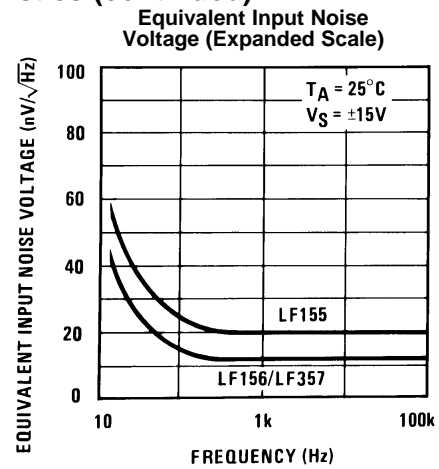
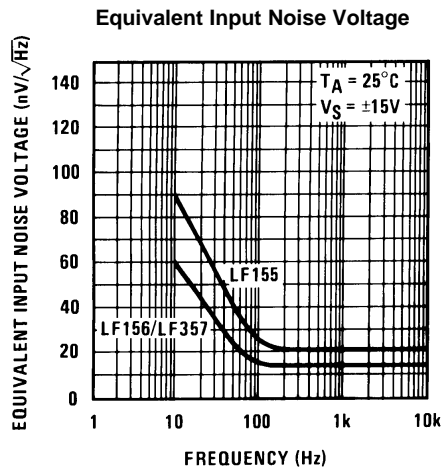

Figure 23.

Typical AC Performance Characteristics (continued)



## APPLICATION HINTS

These are op amps with JFET input devices. These JFETs have large reverse breakdown voltages from gate to source and drain eliminating the need for clamps across the inputs. Therefore large differential input voltages can easily be accommodated without a large increase in input current. The maximum differential input voltage is independent of the supply voltages. However, neither of the input voltages should be allowed to exceed the negative supply as this will cause large currents to flow which can result in a destroyed unit.

Exceeding the negative common-mode limit on either input will force the output to a high state, potentially causing a reversal of phase to the output. Exceeding the negative common-mode limit on both inputs will force the amplifier output to a high state. In neither case does a latch occur since raising the input back within the common-mode range again puts the input stage and thus the amplifier in a normal operating mode.

Exceeding the positive common-mode limit on a single input will not change the phase of the output however, if both inputs exceed the limit, the output of the amplifier will be forced to a high state.

These amplifiers will operate with the common-mode input voltage equal to the positive supply. In fact, the common-mode voltage can exceed the positive supply by approximately 100 mV independent of supply voltage and over the full operating temperature range. The positive supply can therefore be used as a reference on an input as, for example, in a supply current monitor and/or limiter.

Precautions should be taken to ensure that the power supply for the integrated circuit never becomes reversed in polarity or that the unit is not inadvertently installed backwards in a socket as an unlimited current surge through the resulting forward diode within the IC could cause fusing of the internal conductors and result in a destroyed unit.

All of the bias currents in these amplifiers are set by FET current sources. The drain currents for the amplifiers are therefore essentially independent of supply voltage.

As with most amplifiers, care should be taken with lead dress, component placement and supply decoupling in order to ensure stability. For example, resistors from the output to an input should be placed with the body close to the input to minimize “pickup” and maximize the frequency of the feedback pole by minimizing the capacitance from the input to ground.

A feedback pole is created when the feedback around any amplifier is resistive. The parallel resistance and capacitance from the input of the device (usually the inverting input) to AC ground set the frequency of the pole. In many instances the frequency of this pole is much greater than the expected 3dB frequency of the closed loop gain and consequently there is negligible effect on stability margin. However, if the feedback pole is less than approximately six times the expected 3 dB frequency a lead capacitor should be placed from the output to the input of the op amp. The value of the added capacitor should be such that the RC time constant of this capacitor and the resistance it parallels is greater than or equal to the original feedback pole time constant.

## Typical Circuit Connections

Figure 26.  $V_{OS}$  Adjustment

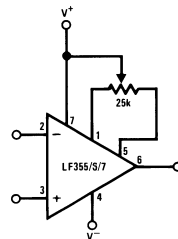

- $V_{OS}$  is adjusted with a 25k potentiometer
- The potentiometer wiper is connected to  $V^+$
- For potentiometers with temperature coefficient of 100 ppm/°C or less the additional drift with adjust is  $\approx 0.5\mu\text{V}/^\circ\text{C}/\text{mV}$  of adjustment
- Typical overall drift:  $5\mu\text{V}/^\circ\text{C} \pm(0.5\mu\text{V}/^\circ\text{C}/\text{mV}$  of adj.)

Figure 27. Driving Capacitive Loads

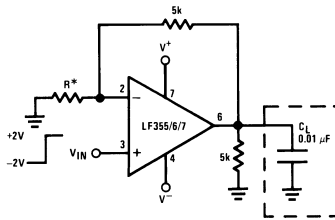

- \* LF156 R = 5k
- Due to a unique output stage design, these amplifiers have the ability to drive large capacitive loads and still maintain stability.  $C_{L(MAX)} \approx 0.01 \mu F$ .
- Overshoot  $\leq 20\%$
- Settling time ( $t_s$ )  $\approx 5 \mu s$

Typical Applications

Figure 28. Settling Time Test Circuit

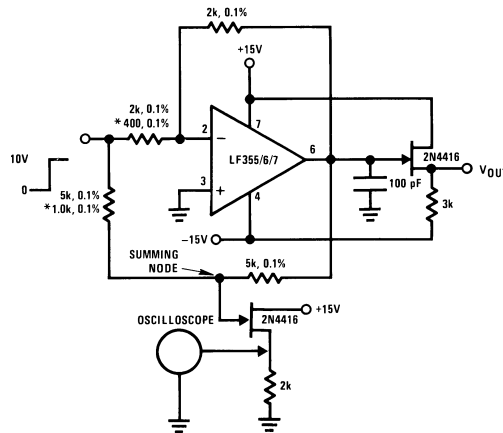

- Settling time is tested with the LF156 connected as unity gain inverter.
- FET used to isolate the probe capacitance
- Output = 10V step

Figure 29. Large Signal Inverter Output,  $V_{OUT}$  (from Settling Time Circuit) LF356

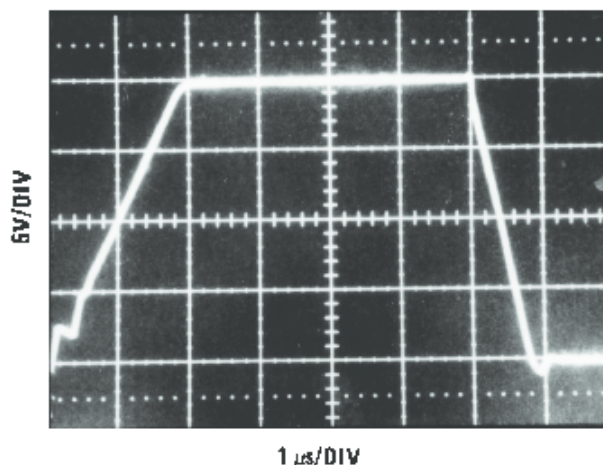
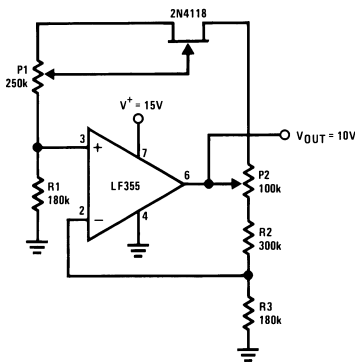
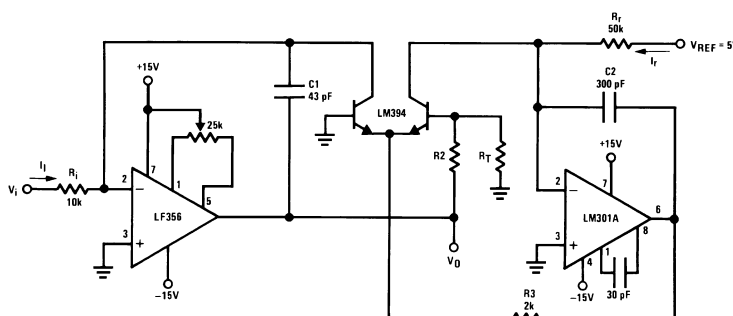

Figure 30. Low Drift Adjustable Voltage Reference



- $\Delta V_{OUT}/\Delta T = \pm 0.002\%/^{\circ}\text{C}$
- All resistors and potentiometers should be wire-wound
- P1: drift adjust
- P2:  $V_{OUT}$  adjust

Figure 31. Fast Logarithmic Converter



- Dynamic range:  $100\mu\text{A} \leq I_i \leq 1\text{mA}$  (5 decades),  $|V_O| = 1\text{V/decade}$
- Transient response:  $3\mu\text{s}$  for  $\Delta I_i = 1$  decade
- C1, C2, R2, R3: added dynamic compensation
- $V_{OS}$  adjust the LF156 to minimize quiescent error
- $R_T$ :
 

$0.3\%/^{\circ}\text{C}$	$ V_{OUT} $	$=$	$\left[ 1 + \frac{R_2}{R_T} \right]$	$\frac{kT}{q}$	$\ln$	$V_i$	$\left[ \frac{R_r}{V_{REF} R_i} \right]$	$=$	$\log$	$V_i$	$\frac{1}{R_i I_r}$	$R_2 = 15.7\text{k}, R_T = 1\text{k}, 0.3\%/^{\circ}\text{C}$	$(\text{for temperature compensation})$
--------------------------	-------------	-----	--------------------------------------	----------------	-------	-------	--	-----	--------	-------	---------------------	---	---

**Figure 32. Precision Current Monitor**

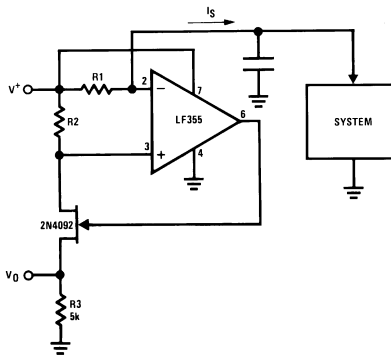

- $V_O = 5 R1/R2$  (V/mA of  $I_S$ )
- R1, R2, R3: 0.1% resistors

**Figure 33. 8-Bit D/A Converter with Symmetrical Offset Binary Operation**

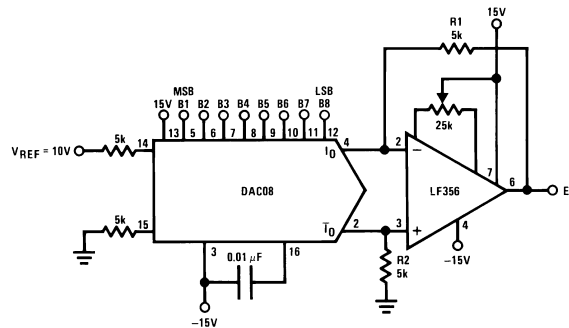

- R1, R2 should be matched within  $\pm 0.05\%$
- Full-scale response time: 3μs

$E_O$	B1	B2	B3	B4	B5	B6	B7	B8	Comments
+9.920	1	1	1	1	1	1	1	1	Positive Full-Scale
+0.040	1	0	0	0	0	0	0	0	(+) Zero-Scale
-0.040	0	1	1	1	1	1	1	1	(-) Zero-Scale
-9.920	0	0	0	0	0	0	0	0	Negative Full-Scale

**Figure 34. Wide BW Low Noise, Low Drift Amplifier**

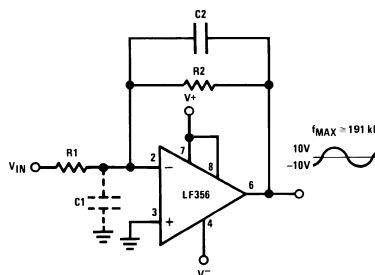

- Power BW:  $f_{MAX} = \frac{S_r}{2\pi V_p} \cong 191 \text{ kHz}$

- Parasitic input capacitance  $C1 \approx 3\text{pF}$  interacts with feedback elements and creates undesirable high frequency pole. To compensate add  $C2$  such that:  $R2 C2 \approx R1 C1$ .

Figure 35. Boosting the LF156 with a Current Amplifier

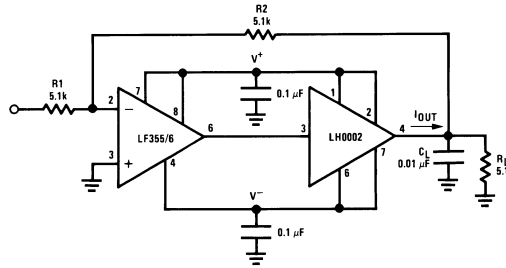

- $I_{OUT(MAX)} \approx 150\text{mA}$  (will drive  $R_L \geq 100\Omega$ )
- $\frac{\Delta V_{OUT}}{\Delta T} = \frac{0.15}{10^{-2}} \text{ V}/\mu\text{s}$  (with  $C_L$  shown)
- No additional phase shift added by the current amplifier

Figure 36. 3 Decades VCO

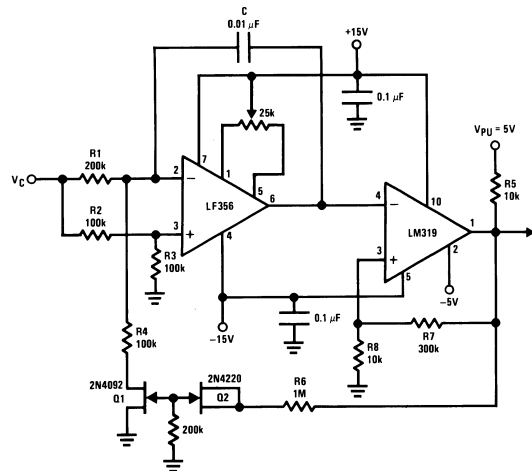

$$f = \frac{V_C (R_8 + R_7)}{(8 V_{PU} R_8 R_1) C'} \quad 0 \leq V_C \leq 30\text{V}, \quad 10 \text{ Hz} \leq f \leq 10 \text{ kHz}$$

R1, R4 matched. Linearity 0.1% over 2 decades.

Figure 37. Isolating Large Capacitive Loads

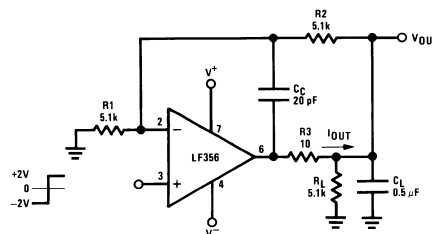

- Overshoot 6%
- $t_s$  10 $\mu$ s
- When driving large  $C_L$ , the  $V_{OUT}$  slew rate determined by  $C_L$  and  $I_{OUT(MAX)}$ :  $\frac{\Delta V_{OUT}}{\Delta T} = \frac{I_{OUT}}{C_L} \cong \frac{0.02}{0.5} \text{ V}/\mu\text{s} = 0.04 \text{ V}/\mu\text{s}$  (with  $C_L$  shown)

Figure 38. Low Drift Peak Detector

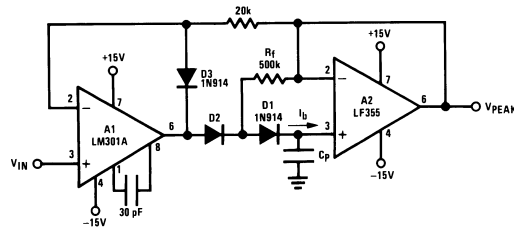

- By adding D1 and R<sub>f</sub>, V<sub>D1</sub>=0 during hold mode. Leakage of D2 provided by feedback path through R<sub>f</sub>.
- Leakage of circuit is essentially I<sub>b</sub> plus capacitor leakage of C<sub>p</sub>.
- Diode D3 clamps V<sub>OUT</sub> (A1) to V<sub>IN</sub>-V<sub>D3</sub> to improve speed and to limit reverse bias of D2.
- Maximum input frequency should be  $\ll \frac{1}{2}\pi R_f C_{D2}$  where C<sub>D2</sub> is the shunt capacitance of D2.

Figure 39. High Impedance, Low Drift Instrumentation Amplifier

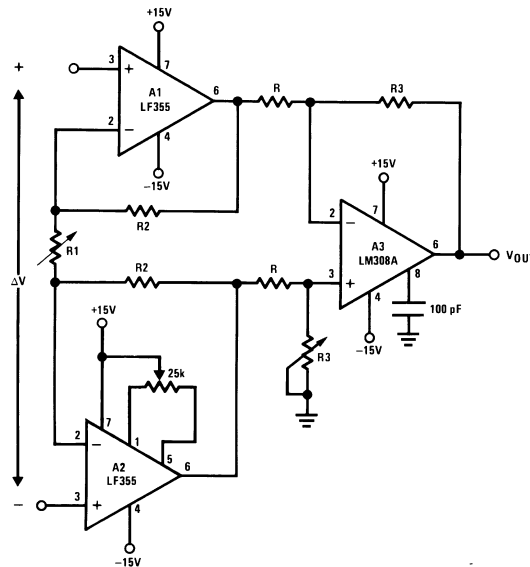

$$V_{OUT} = \frac{R3}{R} \left[ \frac{2R2}{R1} + 1 \right] \Delta V, \quad V^- + 2V \leq V_{IN \text{ common-mode}} \leq V^+$$

- System V<sub>OS</sub> adjusted via A2 V<sub>OS</sub> adjust
- Trim R3 to boost up CMRR to 120 dB. Instrumentation amplifier resistor array recommended for best accuracy and lowest drift

Figure 40. Fast Sample and Hold

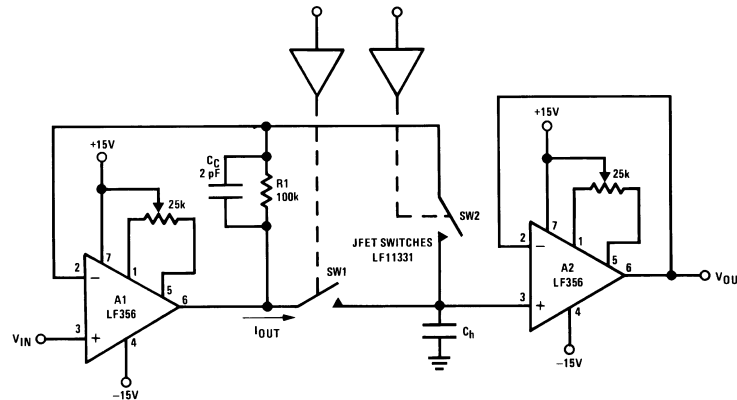

- Both amplifiers (A1, A2) have feedback loops individually closed with stable responses (overshoot negligible)
- Acquisition time  $T_A$ , estimated by:

$$T_A \cong \left[ \frac{2R_{ON} \cdot V_{IN} \cdot C_h}{S_r} \right]^{1/2} \text{ provided that:}$$

$$V_{IN} < 2\pi S_r R_{ON} C_h \text{ and } T_A > \frac{V_{IN} C_h}{I_{OUT(MAX)}}, R_{ON} \text{ is of SW1}$$

$$\text{If inequality not satisfied: } T_A \cong \frac{V_{IN} C_h}{20 \text{ mA}}$$

(1)

- LF156 develops full  $S_r$  output capability for  $V_{IN} \geq 1V$
- Addition of SW2 improves accuracy by putting the voltage drop across SW1 inside the feedback loop
- Overall accuracy of system determined by the accuracy of both amplifiers, A1 and A2

Figure 41. High Accuracy Sample and Hold

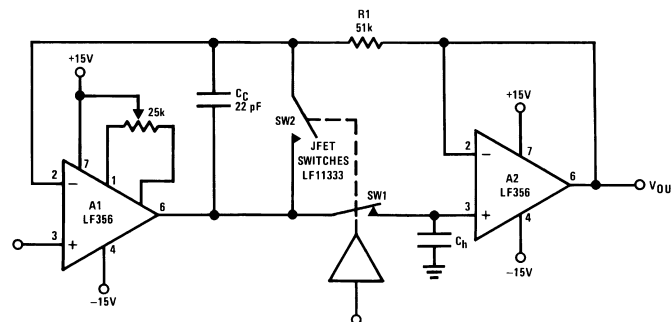

- By closing the loop through A2, the  $V_{OUT}$  accuracy will be determined uniquely by A1.
  - No  $V_{OS}$  adjust required for A2.
- $T_A$  can be estimated by same considerations as previously but, because of the added
  - propagation delay in the feedback loop (A2) the overshoot is not negligible.
- Overall system slower than fast sample and hold
- R1,  $C_C$ : additional compensation
- Use LF156 for
  - Fast settling time
  - Low  $V_{OS}$

Figure 42. High Q Notch Filter

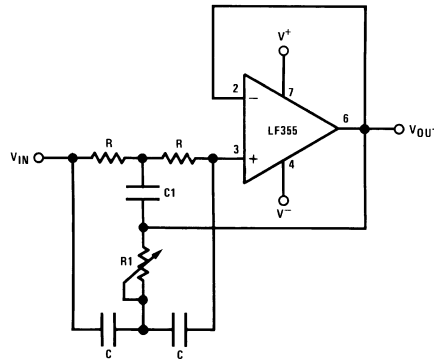

- $2R1 = R = 10M\Omega$ 
  - $2C = C1 = 300pF$
- Capacitors should be matched to obtain high Q
- $f_{NOTCH} = 120\text{ Hz}$ , notch = -55 dB,  $Q > 100$
- Use LF155 for
  - Low  $I_B$
  - Low supply current

Revision History

Date Released	Revision	Section	Originator	Changes
03/10/06	A	New Released, Corporate format. Electrical Section Delete Drift Value table.	R. Malone	New Release, Corporate format 1 MDS data sheet converted into a Corp. data sheet format. Following MDS data sheet will be Archived MNLF156-X, Rev. 2A0. Delete Drift Value table from Electrical Section. Reson: Referenced product is 883 only.
03/25/13	A	All	-	Changed layout of National Data Sheet to TI format.

**PACKAGING INFORMATION**

Orderable Device	Status (1)	Package Type	Package Drawing	Pins	Package Qty	Eco Plan (2)	Lead/Ball Finish	MSL Peak Temp (3)	Op Temp (°C)	Top-Side Markings (4)	Samples
LF156H/883	ACTIVE	TO-99	LMC	8	20	TBD	Call TI	Call TI	-55 to 125	LF156H/883 Q ACO LF156H/883 Q >T	Samples

(1) The marketing status values are defined as follows:

**ACTIVE:** Product device recommended for new designs.

**LIFEBUY:** TI has announced that the device will be discontinued, and a lifetime-buy period is in effect.

**NRND:** Not recommended for new designs. Device is in production to support existing customers, but TI does not recommend using this part in a new design.

**PREVIEW:** Device has been announced but is not in production. Samples may or may not be available.

**OBSELETE:** TI has discontinued the production of the device.

(2) Eco Plan - The planned eco-friendly classification: Pb-Free (RoHS), Pb-Free (RoHS Exempt), or Green (RoHS & no Sb/Br) - please check <http://www.ti.com/productcontent> for the latest availability information and additional product content details.

**TBD:** The Pb-Free/Green conversion plan has not been defined.

**Pb-Free (RoHS):** TI's terms "Lead-Free" or "Pb-Free" mean semiconductor products that are compatible with the current RoHS requirements for all 6 substances, including the requirement that lead not exceed 0.1% by weight in homogeneous materials. Where designed to be soldered at high temperatures, TI Pb-Free products are suitable for use in specified lead-free processes.

**Pb-Free (RoHS Exempt):** This component has a RoHS exemption for either 1) lead-based flip-chip solder bumps used between the die and package, or 2) lead-based die adhesive used between the die and leadframe. The component is otherwise considered Pb-Free (RoHS compatible) as defined above.

**Green (RoHS & no Sb/Br):** TI defines "Green" to mean Pb-Free (RoHS compatible), and free of Bromine (Br) and Antimony (Sb) based flame retardants (Br or Sb do not exceed 0.1% by weight in homogeneous material)

(3) MSL, Peak Temp. -- The Moisture Sensitivity Level rating according to the JEDEC industry standard classifications, and peak solder temperature.

(4) Multiple Top-Side Markings will be inside parentheses. Only one Top-Side Marking contained in parentheses and separated by a "~" will appear on a device. If a line is indented then it is a continuation of the previous line and the two combined represent the entire Top-Side Marking for that device.

**Important Information and Disclaimer:**The information provided on this page represents TI's knowledge and belief as of the date that it is provided. TI bases its knowledge and belief on information provided by third parties, and makes no representation or warranty as to the accuracy of such information. Efforts are underway to better integrate information from third parties. TI has taken and continues to take reasonable steps to provide representative and accurate information but may not have conducted destructive testing or chemical analysis on incoming materials and chemicals. TI and TI suppliers consider certain information to be proprietary, and thus CAS numbers and other limited information may not be available for release.

In no event shall TI's liability arising out of such information exceed the total purchase price of the TI part(s) at issue in this document sold by TI to Customer on an annual basis.

LMC (O-MBCY-W8)

METAL CYLINDRICAL PACKAGE

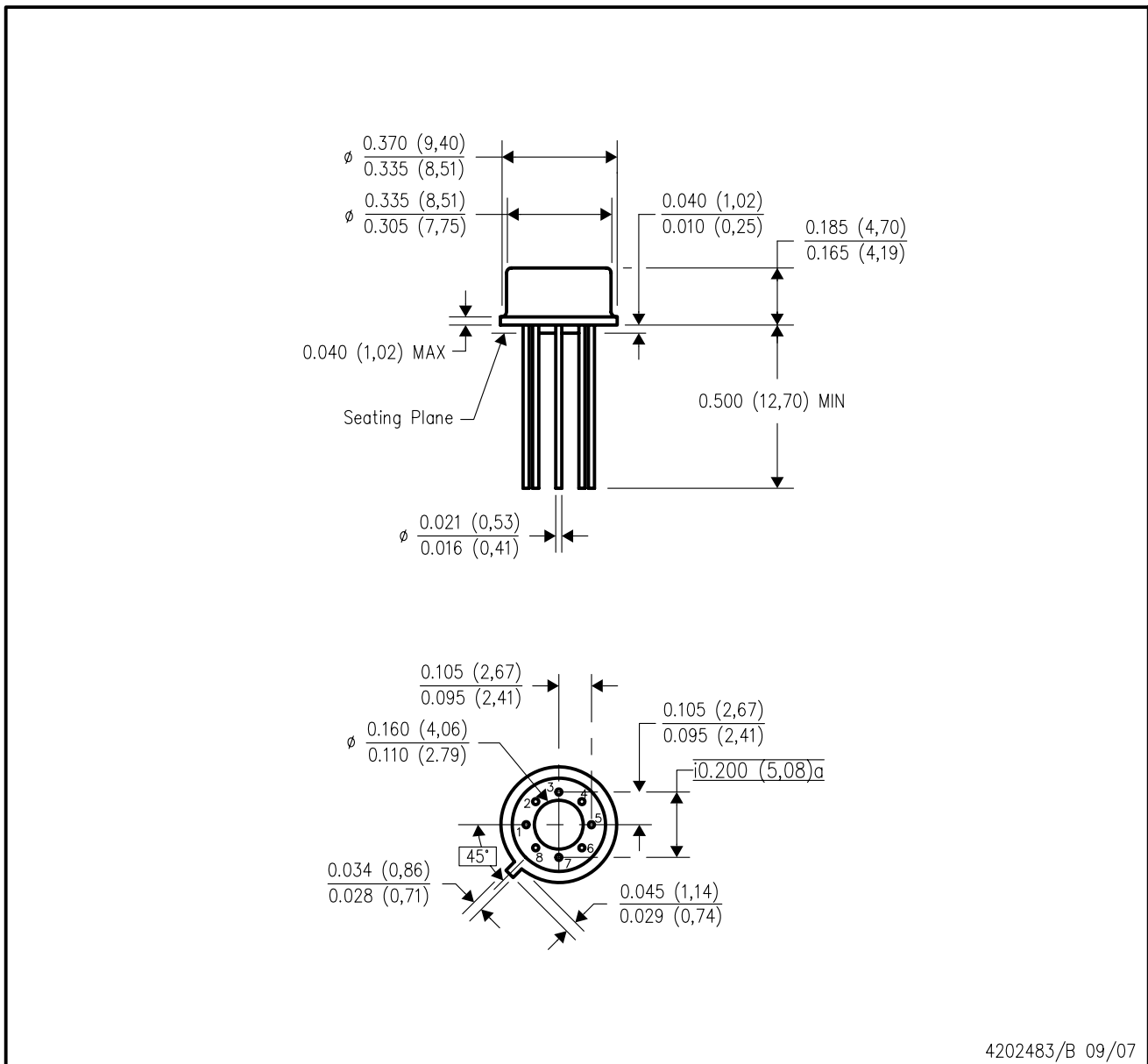

4202483/B 09/07

- NOTES:
- A. All linear dimensions are in inches (millimeters).
  - B. This drawing is subject to change without notice.
  - C. Leads in true position within 0.010 (0,25) R @ MMC at seating plane.
  - D. Pin numbers shown for reference only. Numbers may not be marked on package.
  - E. Falls within JEDEC MO-002/TO-99.

## IMPORTANT NOTICE

Texas Instruments Incorporated and its subsidiaries (TI) reserve the right to make corrections, enhancements, improvements and other changes to its semiconductor products and services per JESD46, latest issue, and to discontinue any product or service per JESD48, latest issue. Buyers should obtain the latest relevant information before placing orders and should verify that such information is current and complete. All semiconductor products (also referred to herein as "components") are sold subject to TI's terms and conditions of sale supplied at the time of order acknowledgment.

TI warrants performance of its components to the specifications applicable at the time of sale, in accordance with the warranty in TI's terms and conditions of sale of semiconductor products. Testing and other quality control techniques are used to the extent TI deems necessary to support this warranty. Except where mandated by applicable law, testing of all parameters of each component is not necessarily performed.

TI assumes no liability for applications assistance or the design of Buyers' products. Buyers are responsible for their products and applications using TI components. To minimize the risks associated with Buyers' products and applications, Buyers should provide adequate design and operating safeguards.

TI does not warrant or represent that any license, either express or implied, is granted under any patent right, copyright, mask work right, or other intellectual property right relating to any combination, machine, or process in which TI components or services are used. Information published by TI regarding third-party products or services does not constitute a license to use such products or services or a warranty or endorsement thereof. Use of such information may require a license from a third party under the patents or other intellectual property of the third party, or a license from TI under the patents or other intellectual property of TI.

Reproduction of significant portions of TI information in TI data books or data sheets is permissible only if reproduction is without alteration and is accompanied by all associated warranties, conditions, limitations, and notices. TI is not responsible or liable for such altered documentation. Information of third parties may be subject to additional restrictions.

Resale of TI components or services with statements different from or beyond the parameters stated by TI for that component or service voids all express and any implied warranties for the associated TI component or service and is an unfair and deceptive business practice. TI is not responsible or liable for any such statements.

Buyer acknowledges and agrees that it is solely responsible for compliance with all legal, regulatory and safety-related requirements concerning its products, and any use of TI components in its applications, notwithstanding any applications-related information or support that may be provided by TI. Buyer represents and agrees that it has all the necessary expertise to create and implement safeguards which anticipate dangerous consequences of failures, monitor failures and their consequences, lessen the likelihood of failures that might cause harm and take appropriate remedial actions. Buyer will fully indemnify TI and its representatives against any damages arising out of the use of any TI components in safety-critical applications.

In some cases, TI components may be promoted specifically to facilitate safety-related applications. With such components, TI's goal is to help enable customers to design and create their own end-product solutions that meet applicable functional safety standards and requirements. Nonetheless, such components are subject to these terms.

No TI components are authorized for use in FDA Class III (or similar life-critical medical equipment) unless authorized officers of the parties have executed a special agreement specifically governing such use.

Only those TI components which TI has specifically designated as military grade or "enhanced plastic" are designed and intended for use in military/aerospace applications or environments. Buyer acknowledges and agrees that any military or aerospace use of TI components which have **not** been so designated is solely at the Buyer's risk, and that Buyer is solely responsible for compliance with all legal and regulatory requirements in connection with such use.

TI has specifically designated certain components as meeting ISO/TS16949 requirements, mainly for automotive use. In any case of use of non-designated products, TI will not be responsible for any failure to meet ISO/TS16949.

### Products

Audio	<a href="http://www.ti.com/audio">www.ti.com/audio</a>
Amplifiers	<a href="http://amplifier.ti.com">amplifier.ti.com</a>
Data Converters	<a href="http://dataconverter.ti.com">dataconverter.ti.com</a>
DLP® Products	<a href="http://www.dlp.com">www.dlp.com</a>
DSP	<a href="http://dsp.ti.com">dsp.ti.com</a>
Clocks and Timers	<a href="http://www.ti.com/clocks">www.ti.com/clocks</a>
Interface	<a href="http://interface.ti.com">interface.ti.com</a>
Logic	<a href="http://logic.ti.com">logic.ti.com</a>
Power Mgmt	<a href="http://power.ti.com">power.ti.com</a>
Microcontrollers	<a href="http://microcontroller.ti.com">microcontroller.ti.com</a>
RFID	<a href="http://www.ti-rfid.com">www.ti-rfid.com</a>
OMAP Applications Processors	<a href="http://www.ti.com/omap">www.ti.com/omap</a>
Wireless Connectivity	<a href="http://www.ti.com/wirelessconnectivity">www.ti.com/wirelessconnectivity</a>

### Applications

Automotive and Transportation	<a href="http://www.ti.com/automotive">www.ti.com/automotive</a>
Communications and Telecom	<a href="http://www.ti.com/communications">www.ti.com/communications</a>
Computers and Peripherals	<a href="http://www.ti.com/computers">www.ti.com/computers</a>
Consumer Electronics	<a href="http://www.ti.com/consumer-apps">www.ti.com/consumer-apps</a>
Energy and Lighting	<a href="http://www.ti.com/energy">www.ti.com/energy</a>
Industrial	<a href="http://www.ti.com/industrial">www.ti.com/industrial</a>
Medical	<a href="http://www.ti.com/medical">www.ti.com/medical</a>
Security	<a href="http://www.ti.com/security">www.ti.com/security</a>
Space, Avionics and Defense	<a href="http://www.ti.com/space-avionics-defense">www.ti.com/space-avionics-defense</a>
Video and Imaging	<a href="http://www.ti.com/video">www.ti.com/video</a>

### TI E2E Community

[e2e.ti.com](http://e2e.ti.com)