

DUAL HALF BRIDGE DRIVER

- HALF BRIDGE OUTPUTS WITH TYPICAL $R_{ON} = 0.7\Omega$
- OUTPUT CURRENT CAPABILITY $\pm 1.2A$
- OPERATING SUPPLY VOLTAGE RANGE 7V TO 16.5V
- SUPPLY OVERVOLTAGE PROTECTION FUNCTION FOR V_{VS} UP TO 40V
- VERY LOW QUIESCENT CURRENT IN STANDBY MODE $< 1\mu A$
- CMOS COMPATIBLE INPUTS WITH HYSTERESIS
- OUTPUT SHORT-CIRCUIT PROTECTION
- THERMAL SHUTDOWN
- REAL TIME DIAGNOSTIC: THERMAL OVERLOAD, OVERVOLTAGE

MULTIPOWER BCD TECHNOLOGY

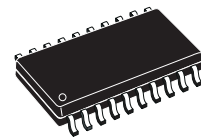

SO20 (12+4+4)

ORDERING NUMBERS: L9997ND
L9997ND013TR

DESCRIPTION

The L9997ND is a monolithic integrated driver, in BCD technology intended to drive various loads,

including DC motors. The circuit is optimized for automotive electronics environmental conditions.

BLOCK DIAGRAM

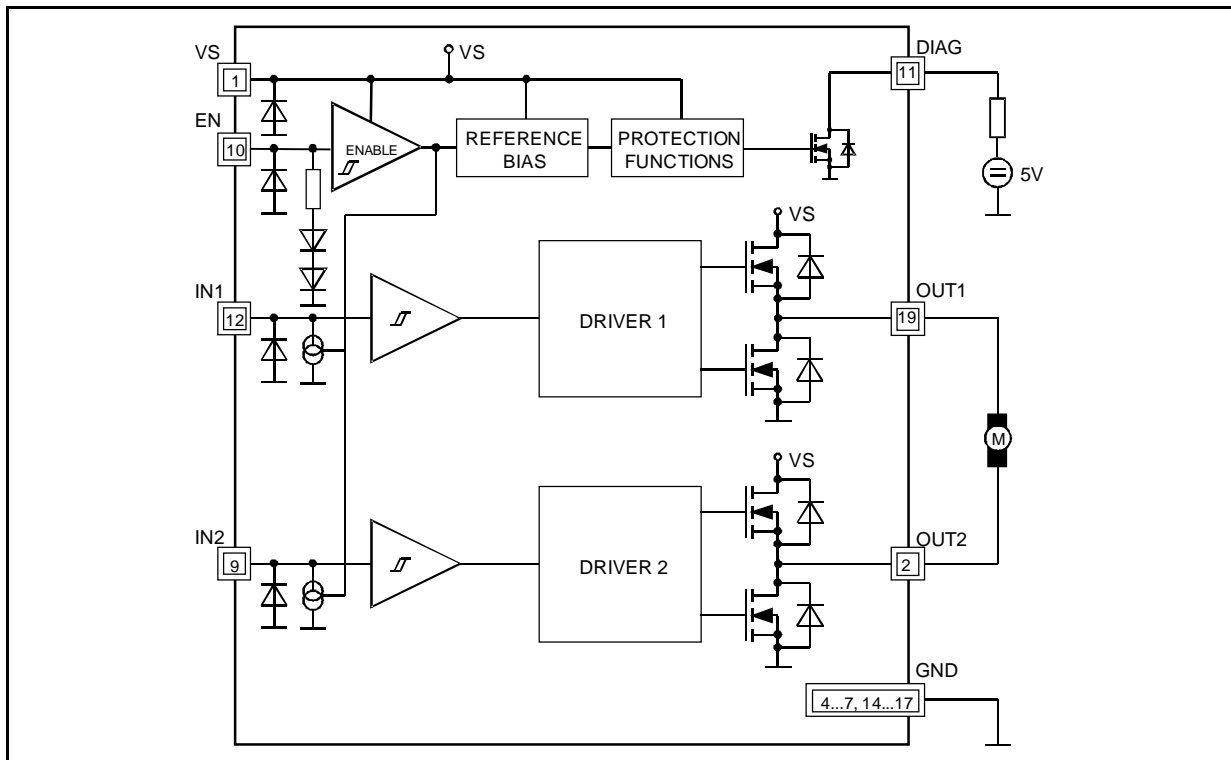

L9997ND

ABSOLUTE MAXIMUM RATINGS

Symbol	Parameter	Value	Unit
V _{VSDC}	DC Supply Voltage	-0.3 to 26	V
V _{VSP}	Supply Voltage Pulse (T < 400ms)	40	V
I _{OUT}	DC Output Current	±1.8	A
V _{IN1,2}	DC Input Voltage	-0.3 to 7	V
V _{EN}	Enable Input Voltage	-0.3 to 7	V
V _{DIAG}	DC Output Voltage	-0.3 to 7	V
I _{OUT}	DC Output Short-circuit Current -0.3V < V _{OUT} < V _S + 0.3V	internally limited	
I _{DIAG}	DC Sink Current -0.3V < V _{DG} < 7V	internally limited	

PIN CONNECTION (Top view)

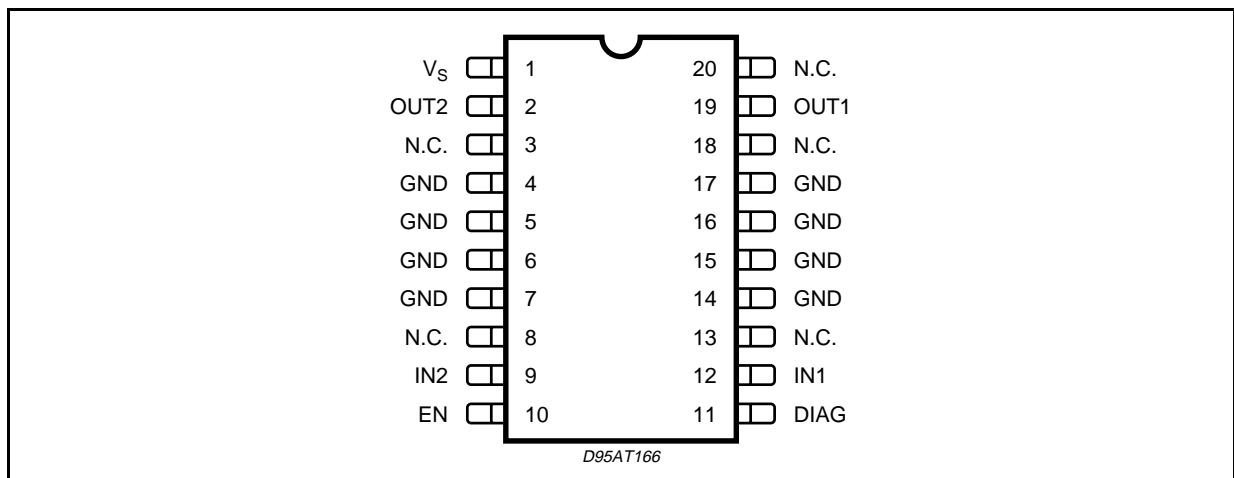

PIN FUNCTIONS

N.	Name	Function
1	VS	Supply Voltage
2	OUT2	Channel 2: Push-Pull power output with intrinsic body diode
3, 8, 13, 18, 20	NC	NC: Not Connected
4 to 7, 14 to 17	GND	Ground: signal - and power - ground, heat sink
9	IN2	Input 2: Schmitt Trigger input with hysteresis (non-inverting signal control)
10	EN	Enable: LOW or not connected on this input switches the device into standby mode and the outputs into tristate
11	DIAG	Diagnostic: Open Drain Output that switches LOW if overvoltage or overtemperature is detected
12	IN1	Input 1: Schmitt Trigger input with hysteresis (non-inverting signal control)

THERMAL DATA

Symbol	Parameter	Value	Unit
T _{JTS}	Thermal Shut-down Junction Temperature	165	°C
T _{JTSH}	Thermal Shut-down Threshold Hysteresis	25	K
R _{th j-amb}	Thermal Resistance Junction-Ambient ⁽¹⁾	50	K/W
R _{th j-pins}	Thermal Resistance Junction-Pins	15	K/W

(1) With 6cm² on board heatsink area.

ELECTRICAL CHARACTERISTICS ($7V < V_S < 16.5V$; $-40^{\circ}C < T_J < 150^{\circ}C$; unless otherwise specified.)

Symbol	Parameter	Test Condition	Min.	Typ.	Max.	Unit
I_{VS_SB}	Quiescent Current in Standby Mode	$V_{EN} < 0.3V$; $V_{VS} < 16.5V$; $T_J < 85^{\circ}C$ $V_{EN} = 0$; $V_{VS} = 14.5V$; $T_J = 25^{\circ}C$		<1 <1	90 10	μA μA
I_{VS}	Supply Current	EN = HIGH, $I_{OUT1,2} = 0$		2	6	mA
V_{ENL}	Low Enable Voltage				1.5	V
V_{ENH}	High Enable Voltage		3.5		6	V
V_{ENthh}	Enable Threshold Hysteresis			1		V
I_{EN}	Enable Input Current	$V_{EN} = 5V$		85	250	μA
$V_{IN1,2L}$	Low Input Voltage				1.5	V
$V_{IN1,2H}$	High Input Voltage		3.5			V
$V_{IN1,2thh}$	Input Threshold Hysteresis			1		V
$I_{IN1,2}$	Input Bias Current	$V_{IN} = 0$ $V_{IN} = 5V$, EN = HIGH	-3 2	0 10	1 50	μA μA
$R_{ON\ OUT1,2}$	ON-Resistance to Supply or GND	$I_{OUT} = \pm 0.8A$; $V_{VS} = 7V$; $T_J = 125^{\circ}C$ $I_{OUT} = \pm 0.8A$; $V_{VS} = 12V$; $T_J = 125^{\circ}C$ $I_{OUT} = \pm 0.8A$; $V_{VS} = 12V$; $T_J = 25^{\circ}C$		1.2 1.1 0.7	2.8 2.25	Ω Ω Ω
$ I_{OUT1,2} $	Output Current Limitation		1.2	1.6	2.2	A
V_{DIAG}	Diagnostic Output Drop	$I_{DIAG} = 0.5mA$, EN = HIGH Overvoltage or Thermal Shut-down			0.6	V
V_{VSOVth}	Supply Overvoltage Threshold		17	19	21	V
t_{ONLH}	Turn on Delay Time	See Fig. 2; $V_{VS} = 13.5V$ Measured with 93Ω load		50	150	μs
t_{ONHL}				30	150	μs
t_{OFFHL}	Turn off Delay Time			10	100	μs
t_{OFFLH}				2	20	μs
t_{dHL}	Rising Delay Time			115	250	μs
t_{dLH}	Falling Delay Time			115	250	μs
t_{rHS}	Rise Time			30	100	μs
t_{rLS}				60	150	μs
t_{fHS}	Fall Time			25	100	μs
t_{fLS}				50	150	μs

* Tested at $125^{\circ}C$ and guaranteed by correlation**FUNCTIONAL DESCRIPTION**

The L9997ND is a motor driver two half-bridge

outputs, intended for driving dc motors in automotive systems. The basic function of the device is shown in the Table 1.

Table 1. Table function.

Status	EN	IN1	IN2	OUT1	OUT2	DIAG	NOTE
1	L	X	X	Tristate	Tristate	OFF	Standby Mode
2	H	H	H	SRC	SRC	OFF	Recommended for braking
3	H	H	L	SRC	SNK	OFF	
4	H	L	H	SNK	SRC	OFF	
5	H	L	L	SNK	SNK	OFF	
6	H	X	X	Tristate	Tristate	ON	Overvoltage or Overtemperature

The device is activated with enable input voltage HIGH. For enable input floating (not connected) or LOW the device is in Standby Mode. Very low quiescent current is defined for $V_{EN} < 0.3V$. When activating or deactivating the device by the enable input a wake-up time of $50\mu s$ is recommended.

For braking of the motor the status 2 is recommended. The reason for this recommendation is that the device features higher threshold for initialisation of parasitic structures than in state 5.

The inputs IN1, IN2 features internal sink current generators of $10\mu A$, disabled in standby mode. With these input current generators the input level is forced to LOW for inputs open. In this condition the outputs are in SNK state.

The circuit features an overvoltage disable function referred to the supply voltage V_{VS} . This function assures disabling the power outputs, when the supply voltage exceeds the over voltage threshold value of $19V$ typ. Both outputs are forced to tristate in this condition and the diagnostic output is ON.

The thermal shut-down disables the outputs (tristate) and activates the diagnostic when the junction temperature increases above the thermal shut-down threshold temperature of min. $150^{\circ}C$. For the start of a heavy loaded motor, if the motor current reaches the max. value, it is necessary to respect the dynamical thermal resistance junction to ambient. The outputs OUT1 and OUT2 are protected against short circuit to GND or V_S , for supply voltages up to the overvoltage disable threshold.

The output power DMOS transistors works in linear mode for an output current less than $1.2A$. Increasing the output load current ($> 1.2A$) the out-

put transistor changes in the current regulation mode, see Fig.6, with the typical output current value below $2A$. The SRC output power DMOS transistors requires a voltage drop $\sim 3V$ to activate the current regulation. Below this voltage drop is the device also protected. The output current heat up the power DMOS transistor, the $R_{DS(ON)}$ increases with the junction temperature and decreases the output current. The power dissipation in this condition can activate the thermal shut-down. In the case of output disable due to thermal overload the output remains disabled until the junction temperature decreases under the thermal enable threshold.

Permanent short circuit condition with power dissipation leading to chip overheating and activation of the thermal shut-down leads to the thermal oscillation. The junction temperature difference between the switch ON and OFF points is the thermal hysteresis of the thermal protection. This hysteresis together with the thermal impedance and ambient temperature determines the frequency of this thermal oscillation, its typical values are in the range of $10kHz$.

The open drain diagnostic output needs an external pull-up resistor to a $5V$ supply. In systems with several L9997ND the diagnostic outputs can be connected together with a common pull-up resistor. The DIAG output current is internally limited.

Fig. 1 shows a typical application diagram for the DC motor driving. To assure the safety of the circuit in the reverse battery condition a reverse protection diode D_1 is necessary. The transient protection diode D_2 must assure that the maximal supply voltage V_{VS} during the transients at the V_{BAT} line will be limited to a value lower than the absolute maximum rating for V_{VS} .

Figure 1: Application Circuit Diagram.

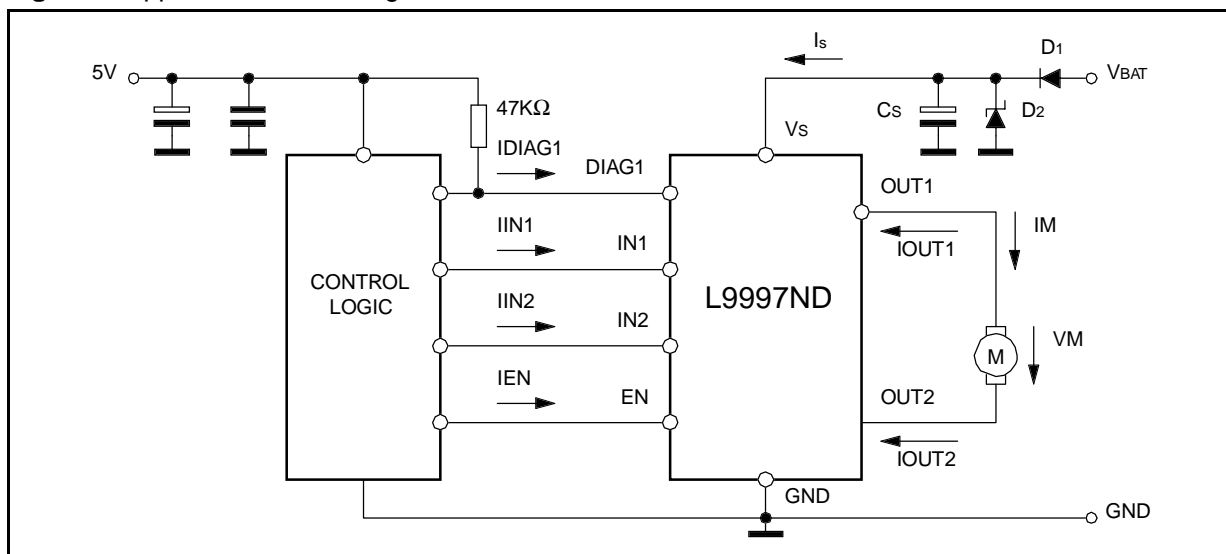

Figure 2. Timing Diagram.

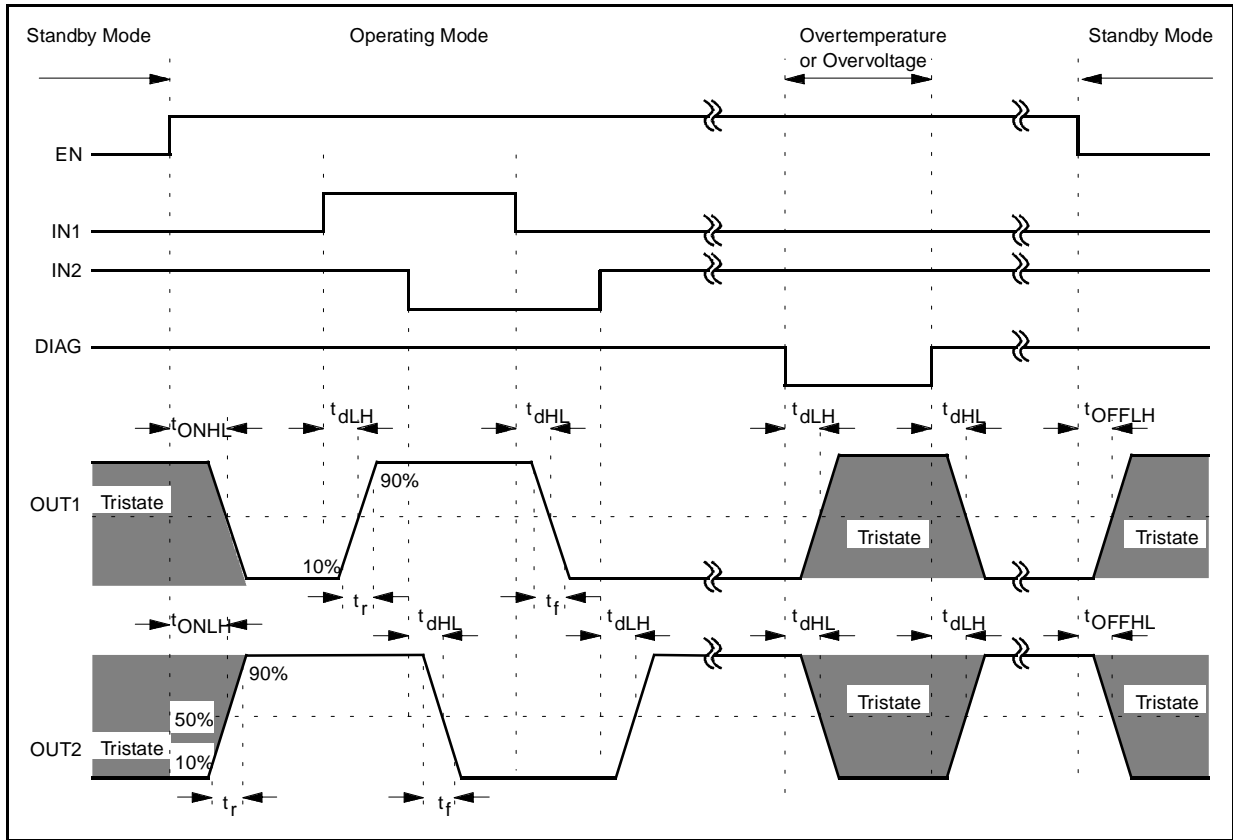

Figure 3. Typical R_{ON} - Characteristics of Source and Sink Stage

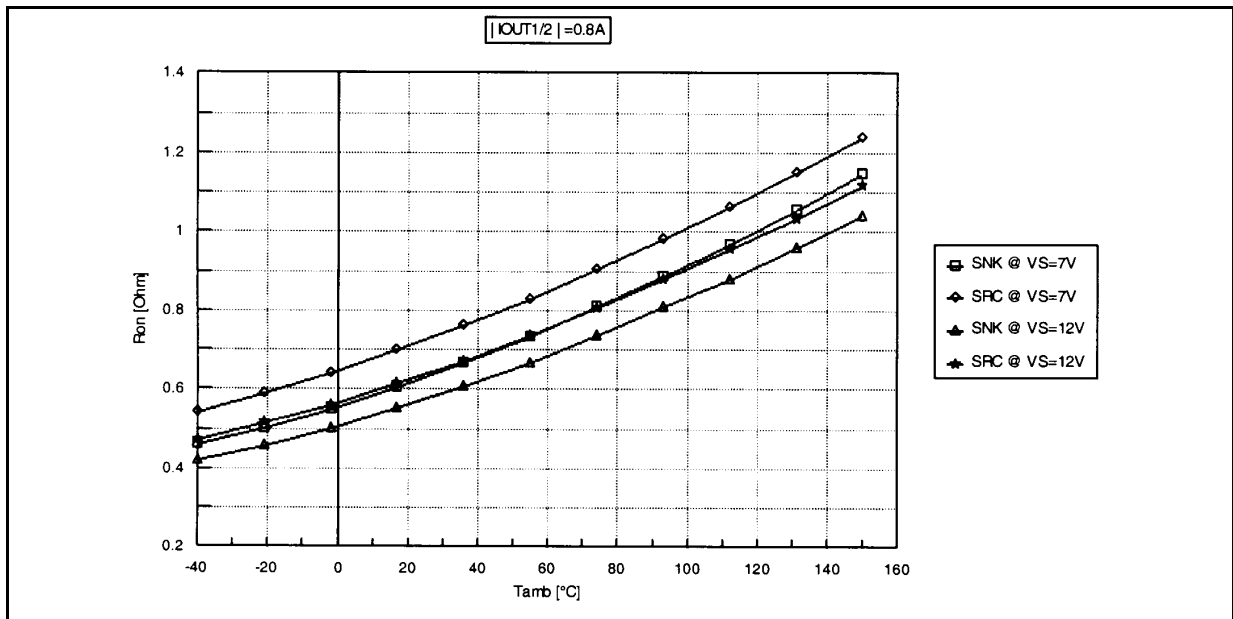

Figure 4. Quiescent current in standby mode versus supply voltage.

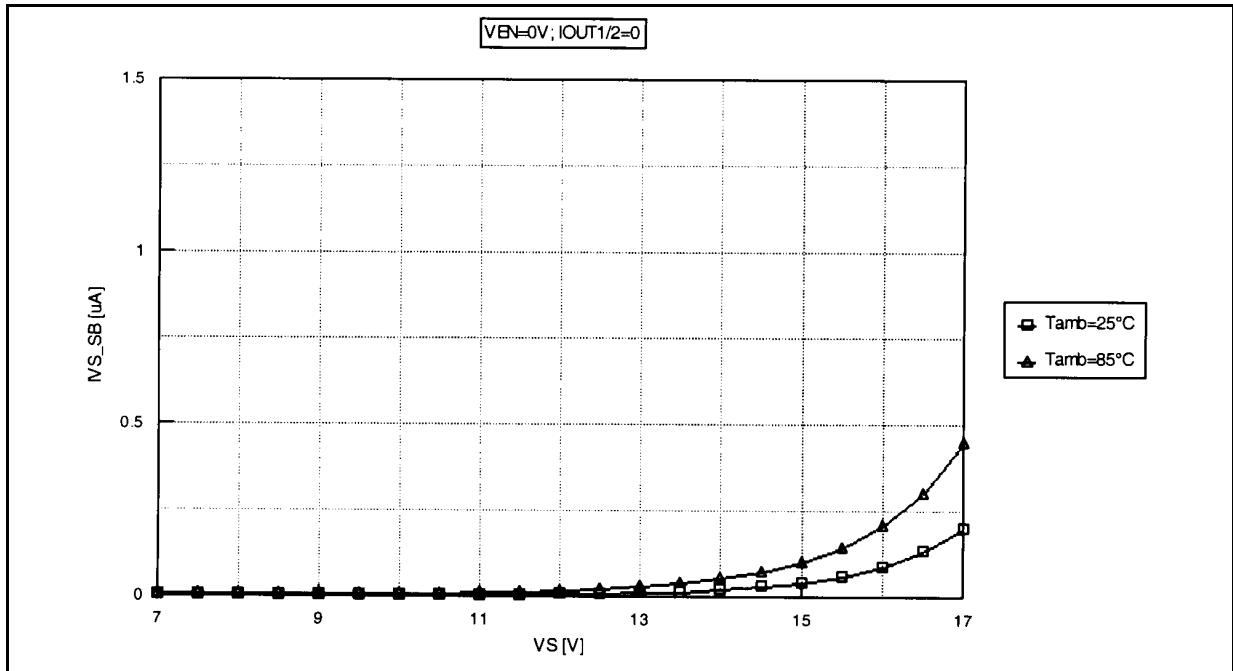

Figure 5. ON-Resistance versus supply voltage.

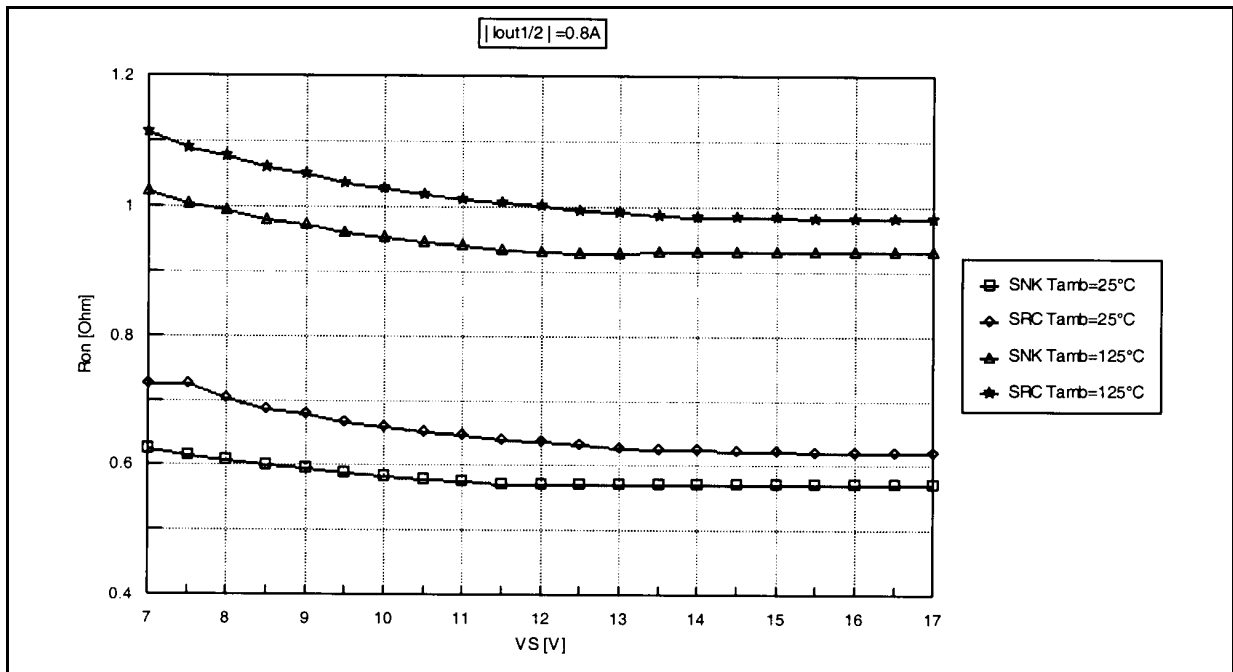

Figure 6. I_{OUT} versus V_{OUT} (pulsed measurement with T_{ON} = 500μs, T_{OFF} = 500ms).

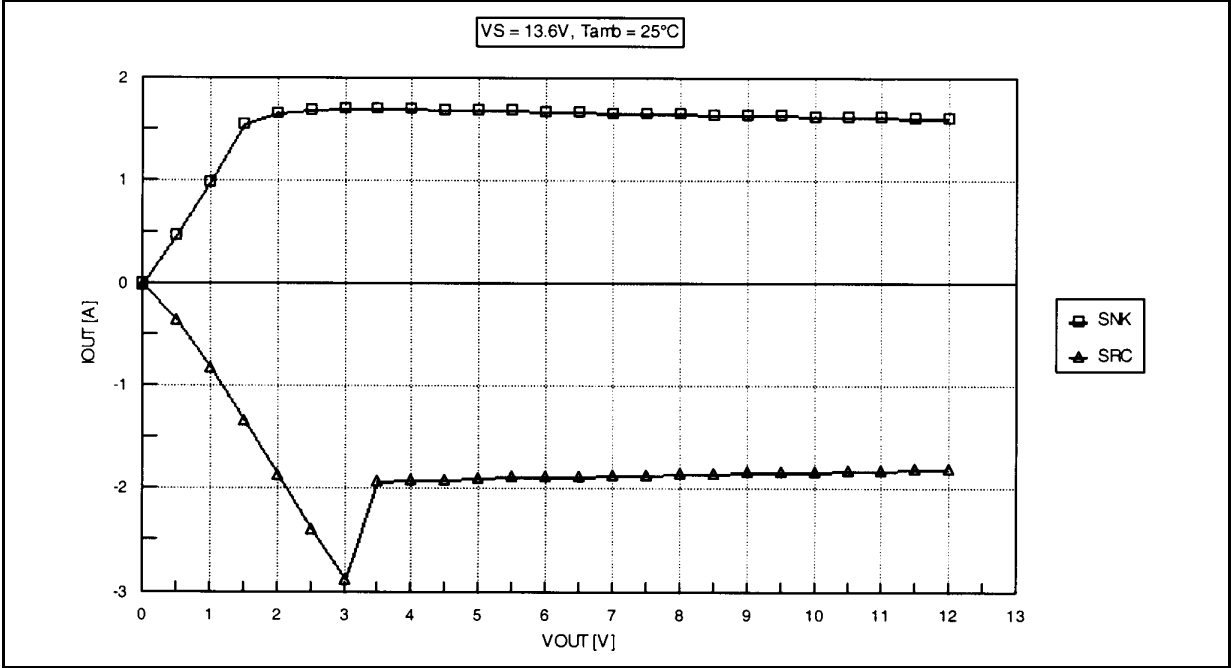
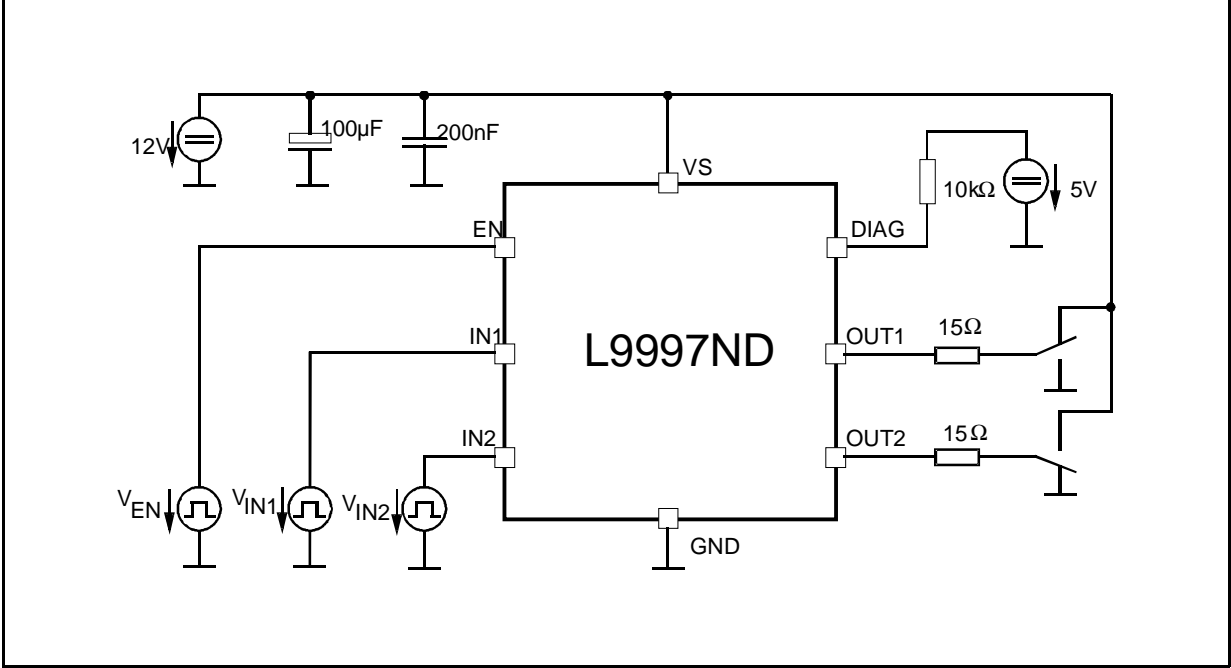
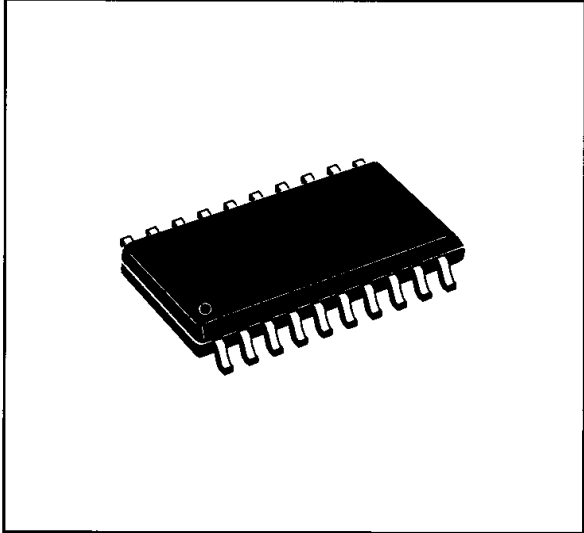

Figure 7. Test circuit.



DIM.	mm			Inch		
	MIN.	TYP.	MAX.	MIN.	TYP.	MAX.
A	2.35		2.65	0.093		0.104
A1	0.1		0.3	0.004		0.012
B	0.33		0.51	0.013		0.020
C	0.23		0.32	0.009		0.013
D	12.6		13	0.496		0.512
E	7.4		7.6	0.291		0.299
e		1.27			0.050	
H	10		10.65	0.394		0.419
h	0.25		0.75	0.010		0.030
L	0.4		1.27	0.016		0.050
K	0° (min.)8° (max.)					

OUTLINE AND MECHANICAL DATA



SO20

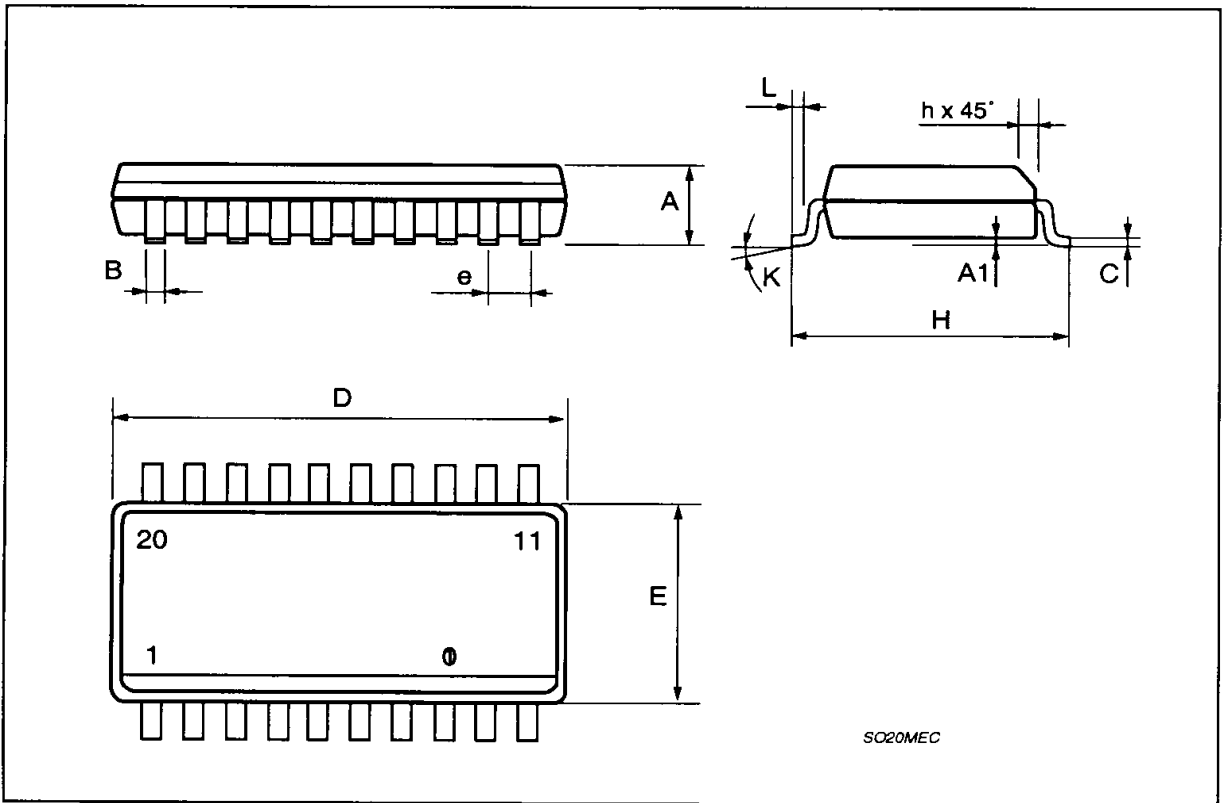

SO20MEC

Information furnished is believed to be accurate and reliable. However, STMicroelectronics assumes no responsibility for the consequences of use of such information nor for any infringement of patents or other rights of third parties which may result from its use. No license is granted by implication or otherwise under any patent or patent rights of STMicroelectronics. Specification mentioned in this publication are subject to change without notice. This publication supersedes and replaces all information previously supplied. STMicroelectronics products are not authorized for use as critical components in life support devices or systems without express written approval of STMicroelectronics.

The ST logo is a registered trademark of STMicroelectronics

© 1999 STMicroelectronics – Printed in Italy – All Rights Reserved

STMicroelectronics GROUP OF COMPANIES

Australia - Brazil - Canada - China - France - Germany - Italy - Japan - Korea - Malaysia - Malta - Mexico - Morocco - The Netherlands - Singapore - Spain - Sweden - Switzerland - Taiwan - Thailand - United Kingdom - U.S.A.

<http://www.st.com>