

## Positive voltage regulators

### Features

- Output current to 1.5 A
- Output voltages of 5; 6; 8; 8.5; 9; 12; 15; 18; 24 V
- Thermal overload protection
- Short circuit protection
- Output transition SOA protection

### Description

The L78xx series of three-terminal positive regulators is available in TO-220, TO-220FP, TO-3, D<sup>2</sup>PAK and DPAK packages and several fixed output voltages, making it useful in a wide range of applications. These regulators can provide local on-card regulation, eliminating the distribution problems associated with single point regulation. Each type employs internal current limiting, thermal shut-down and safe area protection, making it essentially indestructible. If adequate heat sinking is provided, they can deliver over 1 A output current. Although designed primarily as fixed voltage regulators, these devices can be used with external components to obtain adjustable voltage and currents.

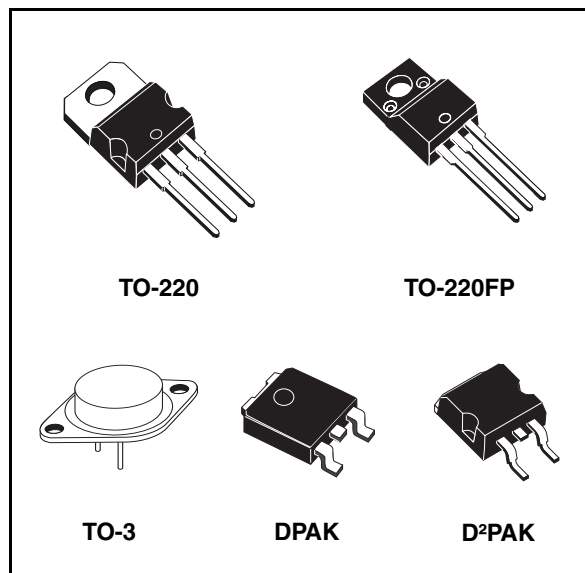

**Table 1. Device summary**

Part numbers	
L7805	L7809C
L7805C	L7812C
L7806C	L7815C
L7808C	L7818C
L7885C	L7824C

### 3 Maximum ratings

**Table 2. Absolute maximum ratings**

Symbol	Parameter		Value	Unit
$V_I$	DC input voltage	for $V_O = 5$ to $18$ V	35	V
		for $V_O = 20, 24$ V	40	
$I_O$	Output current		Internally limited	
$P_D$	Power dissipation		Internally limited	
$T_{STG}$	Storage temperature range		-65 to 150	°C
$T_{OP}$	Operating junction temperature range	for L7800	-55 to 150	°C
		for L7800C	0 to 150	

*Note: Absolute maximum ratings are those values beyond which damage to the device may occur. Functional operation under these condition is not implied.*

**Table 3. Thermal data**

Symbol	Parameter	D <sup>2</sup> PAK	DPAK	TO-220	TO-220FP	TO-3	Unit
$R_{thJC}$	Thermal resistance junction-case	3	8	5	5	4	°C/W
$R_{thJA}$	Thermal resistance junction-ambient	62.5	100	50	60	35	°C/W

**Figure 4. Application circuits**

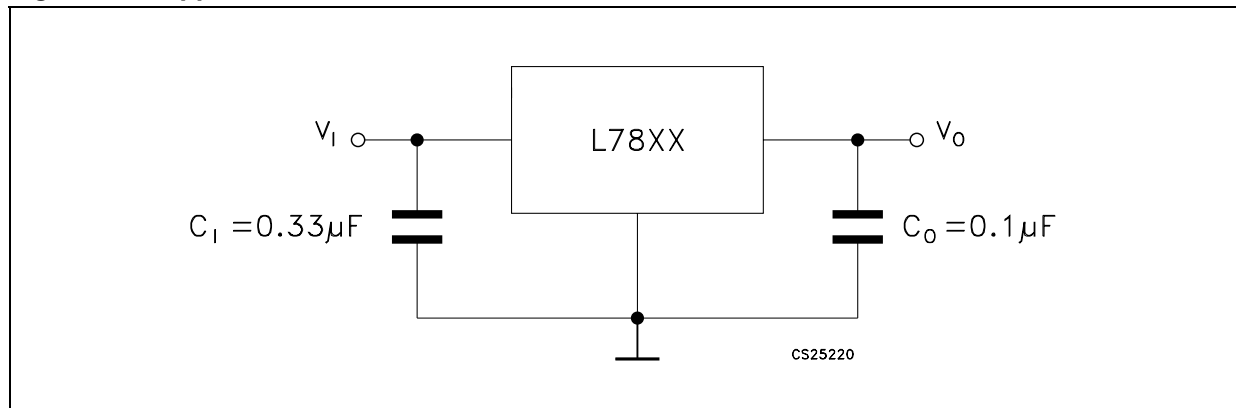

## 5 Electrical characteristics

**Table 4. Electrical characteristics of L7805** (refer to the test circuits,  $T_J = -55$  to  $150$  °C,  $V_I = 10$  V,  $I_O = 500$  mA,  $C_I = 0.33$   $\mu$ F,  $C_O = 0.1$   $\mu$ F unless otherwise specified)

Symbol	Parameter	Test conditions	Min.	Typ.	Max.	Unit
$V_O$	Output voltage	$T_J = 25^\circ\text{C}$	4.8	5	5.2	V
$V_O$	Output voltage	$I_O = 5$ mA to 1 A, $P_O \leq 15$ W $V_I = 8$ to 20 V	4.65	5	5.35	V
$\Delta V_O^{(1)}$	Line regulation	$V_I = 7$ to 25 V, $T_J = 25^\circ\text{C}$		3	50	mV
		$V_I = 8$ to 12 V, $T_J = 25^\circ\text{C}$		1	25	
$\Delta V_O^{(1)}$	Load regulation	$I_O = 5$ mA to 1.5 A, $T_J = 25^\circ\text{C}$			100	mV
		$I_O = 250$ to 750 mA, $T_J = 25^\circ\text{C}$			25	
$I_d$	Quiescent current	$T_J = 25^\circ\text{C}$			6	mA
$\Delta I_d$	Quiescent current change	$I_O = 5$ mA to 1 A			0.5	mA
		$V_I = 8$ to 25 V			0.8	
$\Delta V_O/\Delta T$	Output voltage drift	$I_O = 5$ mA		0.6		mV/°C
eN	Output noise voltage	B = 10 Hz to 100 kHz, $T_J = 25^\circ\text{C}$			40	$\mu\text{V}/V_O$
SVR	Supply voltage rejection	$V_I = 8$ to 18 V, $f = 120$ Hz	68			dB
$V_d$	Dropout voltage	$I_O = 1$ A, $T_J = 25^\circ\text{C}$		2	2.5	V
$R_O$	Output resistance	$f = 1$ kHz		17		m $\Omega$
$I_{sc}$	Short circuit current	$V_I = 35$ V, $T_J = 25^\circ\text{C}$		0.75	1.2	A
$I_{scp}$	Short circuit peak current	$T_J = 25^\circ\text{C}$	1.3	2.2	3.3	A

1. Load and line regulation are specified at constant junction temperature. Changes in  $V_O$  due to heating effects must be taken into account separately. Pulse testing with low duty cycle is used.

**Table 19. Electrical characteristics of L7812C** (refer to the test circuits,  $T_J = 0$  to  $150$  °C,  $V_I = 19$  V,  $I_O = 500$  mA,  $C_I = 0.33$   $\mu$ F,  $C_O = 0.1$   $\mu$ F unless otherwise specified)

Symbol	Parameter	Test conditions	Min.	Typ.	Max.	Unit
$V_O$	Output voltage	$T_J = 25^\circ\text{C}$	11.5	12	12.5	V
$V_O$	Output voltage	$I_O = 5$ mA to $1$ A, $P_O \leq 15$ W $V_I = 14.5$ to $27$ V	11.4	12	12.6	V
$\Delta V_O^{(1)}$	Line regulation	$V_I = 14.5$ to $30$ V, $T_J = 25^\circ\text{C}$			240	mV
		$V_I = 16$ to $22$ V, $T_J = 25^\circ\text{C}$			120	
$\Delta V_O^{(1)}$	Load regulation	$I_O = 5$ mA to $1.5$ A, $T_J = 25^\circ\text{C}$			240	mV
		$I_O = 250$ to $750$ mA, $T_J = 25^\circ\text{C}$			120	
$I_d$	Quiescent current	$T_J = 25^\circ\text{C}$			8	mA
$\Delta I_d$	Quiescent current change	$I_O = 5$ mA to $1$ A			0.5	mA
		$V_I = 14.5$ to $30$ V			1	
$\Delta V_O/\Delta T$	Output voltage drift	$I_O = 5$ mA		-1		mV/°C
eN	Output noise voltage	$B = 10$ Hz to $100$ kHz, $T_J = 25^\circ\text{C}$		75		$\mu\text{V}/V_O$
SVR	Supply voltage rejection	$V_I = 15$ to $25$ V, $f = 120$ Hz	55			dB
$V_d$	Dropout voltage	$I_O = 1$ A, $T_J = 25^\circ\text{C}$		2		V
$R_O$	Output resistance	$f = 1$ kHz		18		m $\Omega$
$I_{sc}$	Short circuit current	$V_I = 35$ V, $T_J = 25^\circ\text{C}$		0.35		A
$I_{scp}$	Short circuit peak current	$T_J = 25^\circ\text{C}$		2.2		A

1. Load and line regulation are specified at constant junction temperature. Changes in  $V_O$  due to heating effects must be taken into account separately. Pulse testing with low duty cycle is used.

Figure 38. Drawing dimension TO-220 (type SMIC-subcon.)

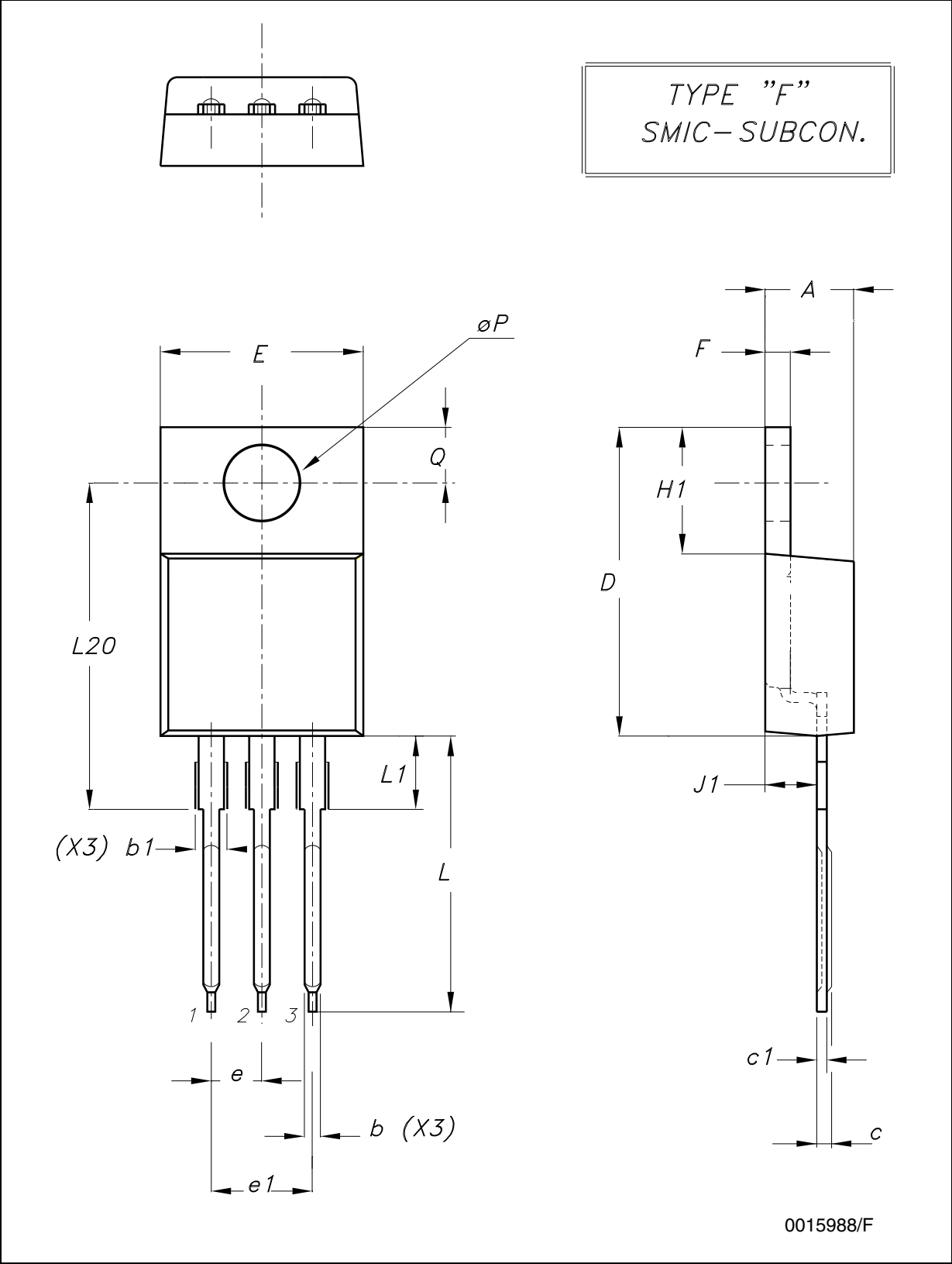
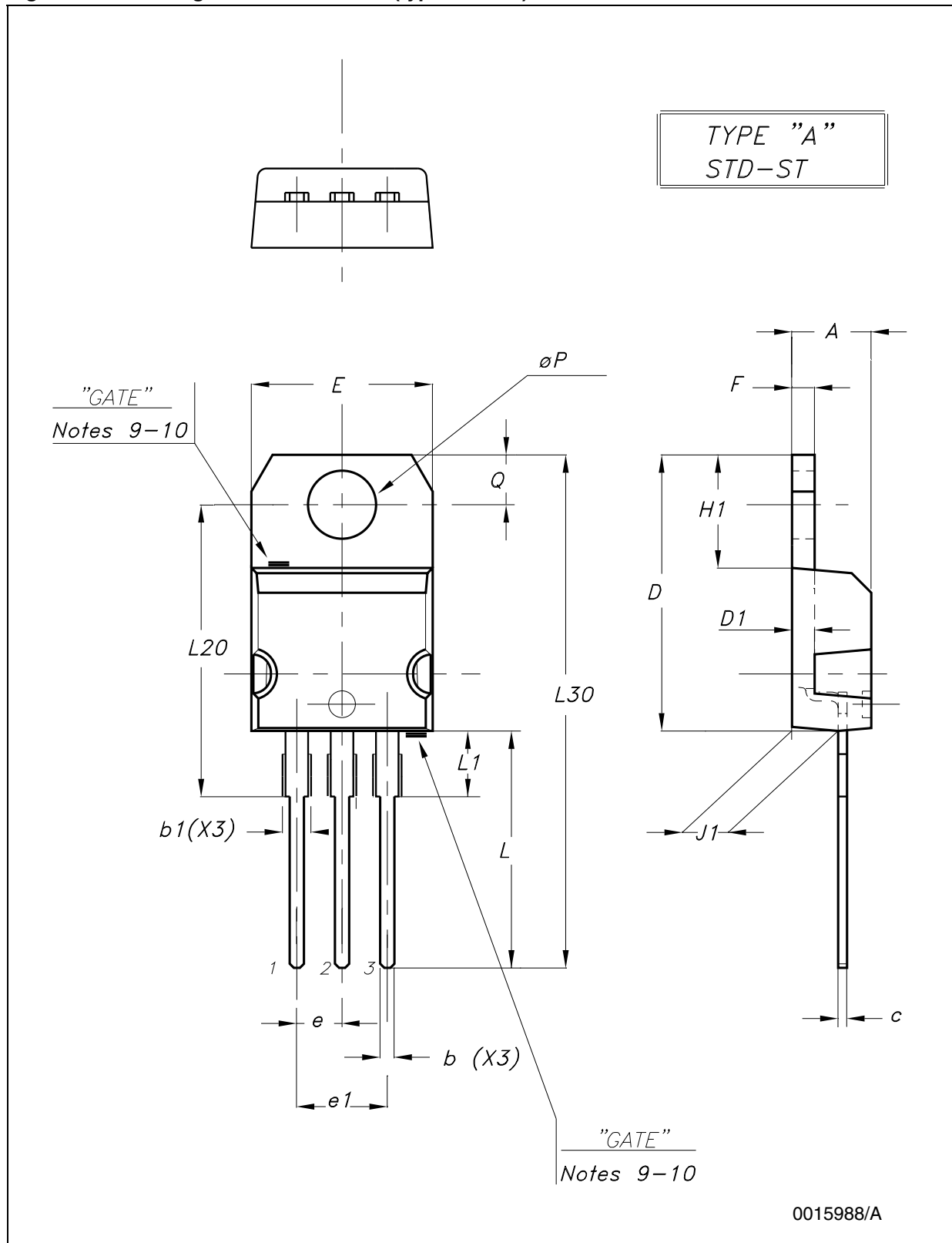

Figure 39. Drawing dimension TO-220 (type STD-ST)



**Table 24. TO-220 mechanical data**

Dim.	Type STD-ST			Type SMIC-Subcon.		
	mm.			mm.		
	Min.	Typ.	Max.	Min.	Typ.	Max.
A	4.40		4.60	4.47	4.57	4.67
A1	0.61		0.88	0.80	0.81	0.86
b1	1.14		1.70	1.15		1.44
c	0.49		0.70		0.56	
c1					0.38	
D	15.25		15.75	15.07	15.24	15.45
D1		1.27				
E	10.00		10.40	10	10.15	10.30
e	2.40		2.70	2.29	2.54	2.79
e1	4.95		5.15	4.83	5.08	5.33
F	1.23		1.32		1.27	
H1	6.20		6.60		6.24	
J1	2.40		2.72	2.04	2.67	2.92
L	13.00		14.00	13.35	13.50	13.65
L1	3.50		3.93		3.90	
L20		16.40		16.25	16.40	16.55
L30		28.90			28.74	
ØP	3.75		3.85		3.83	
Q	2.65		2.95	2.72	2.74	2.80

*Note: In spite of some difference in tolerances, the packages are compatible.*

## 8 Order codes

Table 32. Order codes

Part numbers	Order codes				
	TO-220	DPAK	D <sup>2</sup> PAK	TO-220FP	TO-3
L7805					L7805T
L7805C	L7805CV	L7805CDT-TR	L7805CD2T-TR	L7805CP	L7805CT
L7806C	L7806CV		L7806CD2T-TR		L7806CT
L7808C	L7808CV		L7808CD2T-TR	L7808CP	
L7885C	L7885CV		L7885CD2T-TR <sup>(1)</sup>	L7885CP <sup>(1)</sup>	L7885CT <sup>(1)</sup>
L7809C	L7809CV		L7809CD2T-TR	L7809CP	
L7812C	L7812CV		L7812CD2T-TR	L7812CP	L7812CT
L7815C	L7815CV		L7815CD2T-TR	L7815CP	L7815CT
L7818C	L7818CV		L7818CD2T-TR <sup>(1)</sup>		L7818CT
L7824C	L7824CV		L7824CD2T-TR	L7824CP	L7824CT

1. Available on request.