

Distributed by:

JAMECO[®]
ELECTRONICS

www.Jameco.com ♦ 1-800-831-4242

The content and copyrights of the attached
material are the property of its owner.

Jameco Part Number 924609

Positive voltage regulators

Feature summary

- Output current to 1.5A
- Output voltages of 5; 5.2; 6; 8; 8.5; 9; 10; 12; 15; 18; 24V
- Thermal overload protection
- Short circuit protection
- Output transition SOA protection

Description

The L7800 series of three-terminal positive regulators is available in TO-220, TO-220FP, TO-3 and D²PAK packages and several fixed output voltages, making it useful in a wide range of applications. These regulators can provide local on-card regulation, eliminating the distribution problems associated with single point regulation. Each type employs internal current limiting, thermal shut-down and safe area protection, making it essentially indestructible. If adequate heat sinking is provided, they can deliver over 1A output current. Although designed

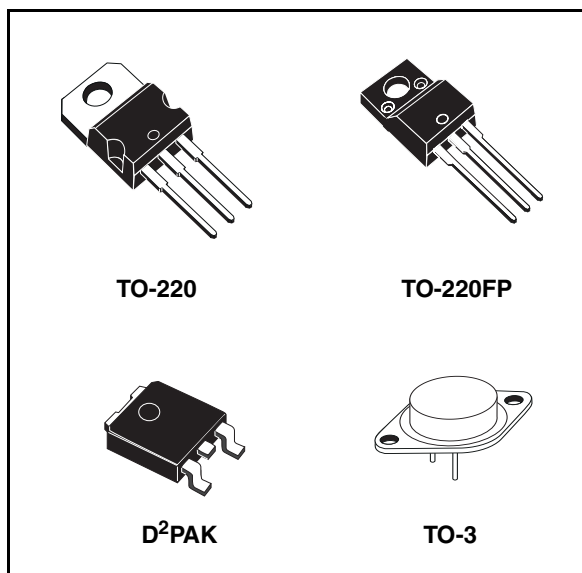

primarily as fixed voltage regulators, these devices can be used with external components to obtain adjustable voltage and currents.

Schematic diagram

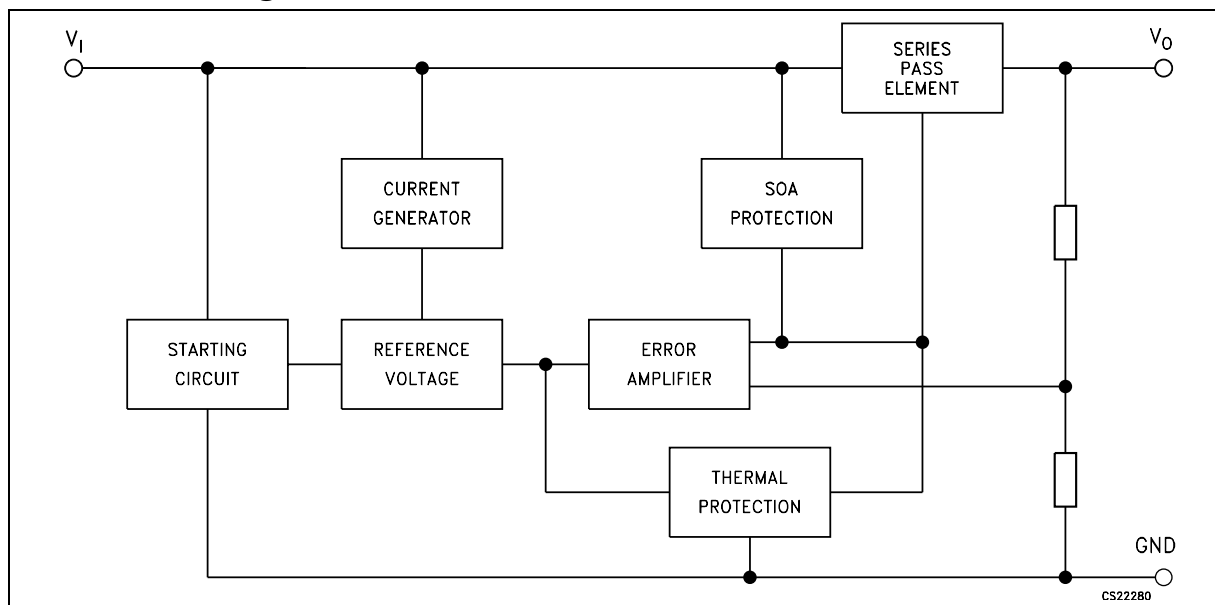

Contents

1	Pin configuration	3
2	Maximum ratings	4
3	Test circuits	5
4	Electrical characteristics	6
5	Typical performance	26
6	Package mechanical data	36
7	Order code	46
8	Revision history	47

1 Pin configuration

Figure 1. Pin connections (top view)

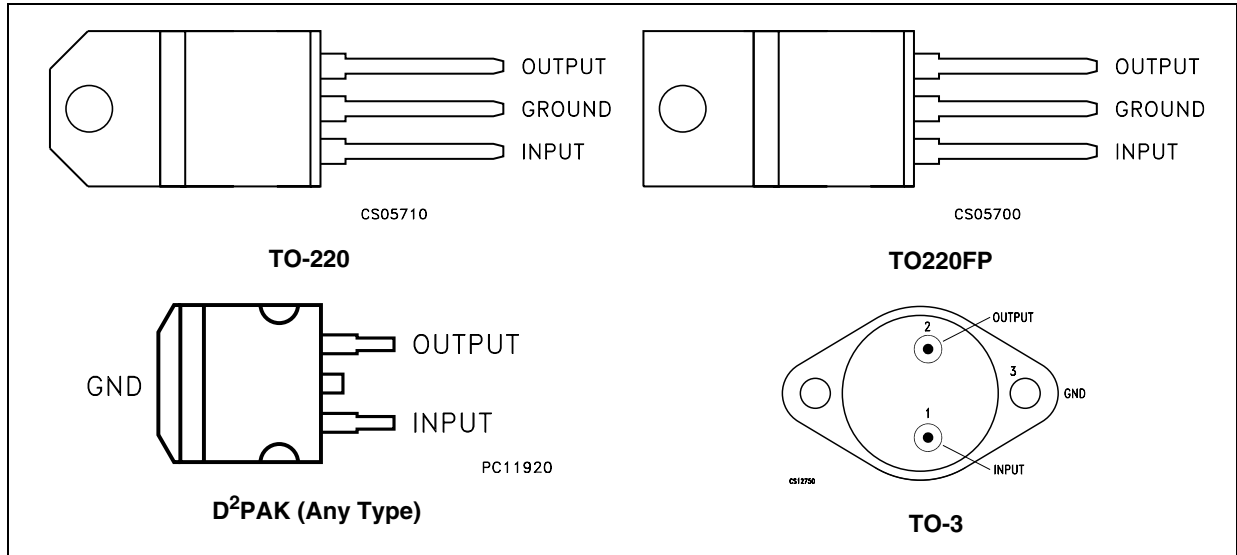
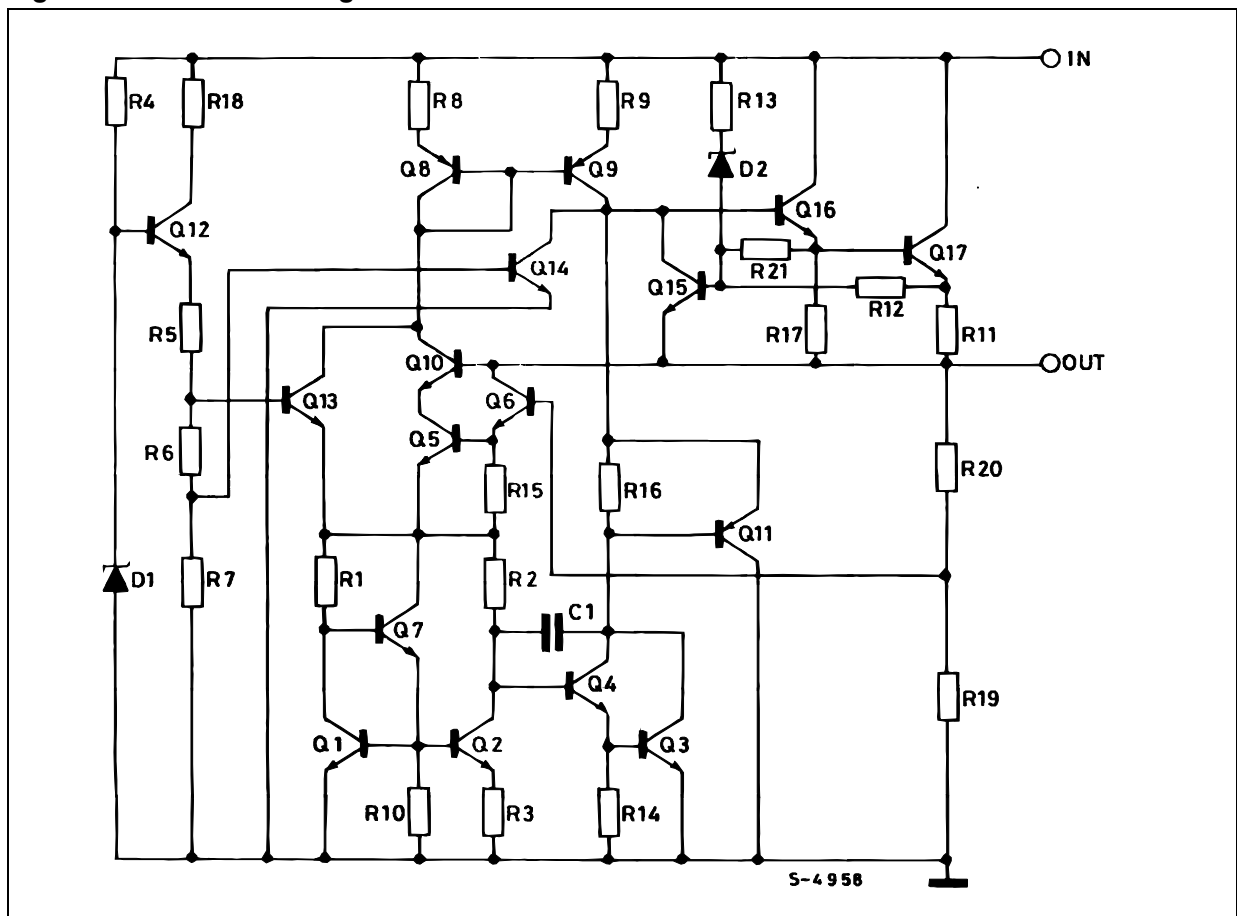

Figure 2. Schematic diagram



2 Maximum ratings

Table 1. Absolute maximum ratings

Symbol	Parameter		Value	Unit
V_I	DC Input voltage	for $V_O = 5$ to $18V$	35	V
		for $V_O = 20, 24V$	40	
I_O	Output current		Internally Limited	
P_D	Power dissipation		Internally Limited	
T_{STG}	Storage temperature range		-65 to 150	°C
T_{OP}	Operating junction temperature range	for L7800	-55 to 150	°C
		for L7800C	0 to 150	

Note: Absolute Maximum Ratings are those values beyond which damage to the device may occur. Functional operation under these condition is not implied

Table 2. Thermal Data

Symbol	Parameter	D ² PAK	TO-220	TO-220FP	TO-3	Unit
R_{thJC}	Thermal resistance junction-case	3	5	5	4	°C/W
R_{thJA}	Thermal resistance junction-ambient	62.5	50	60	35	°C/W

Figure 3. Application circuits

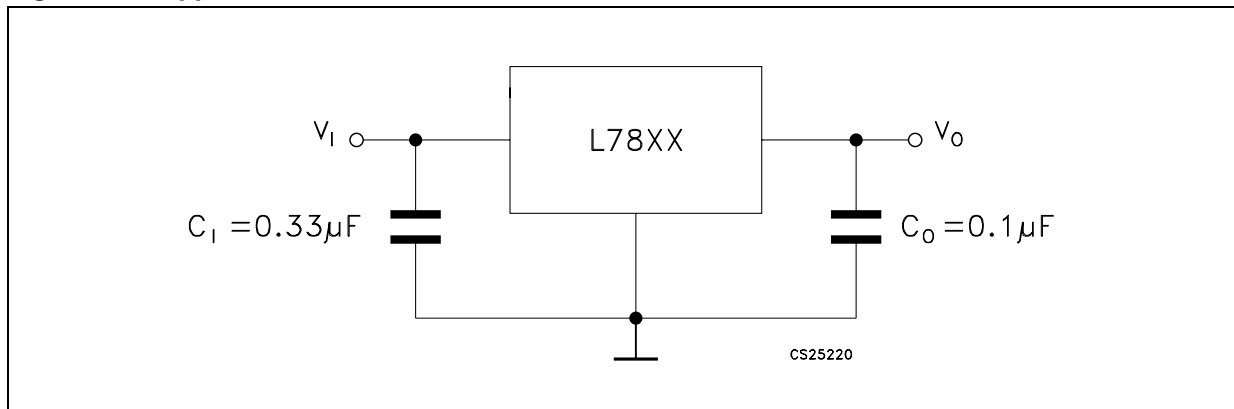

3 Test circuits

Figure 4. DC Parameter

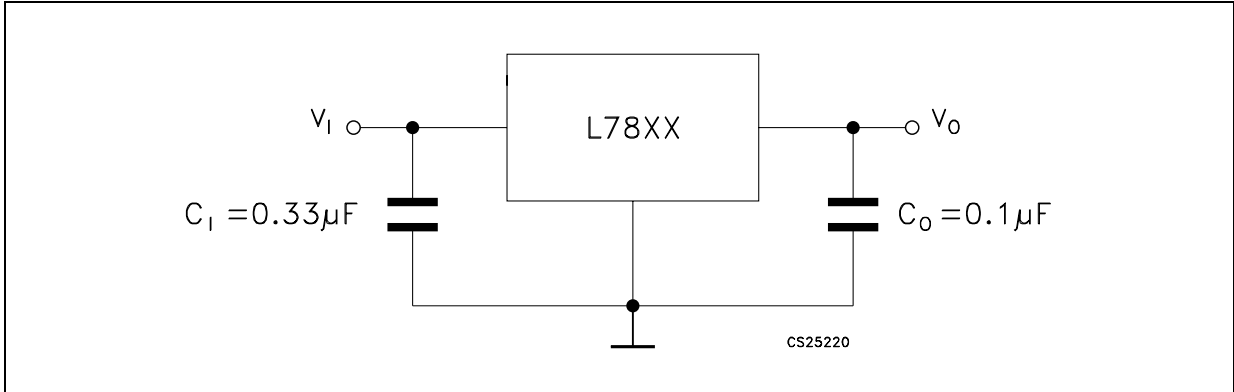

Figure 5. Load regulation

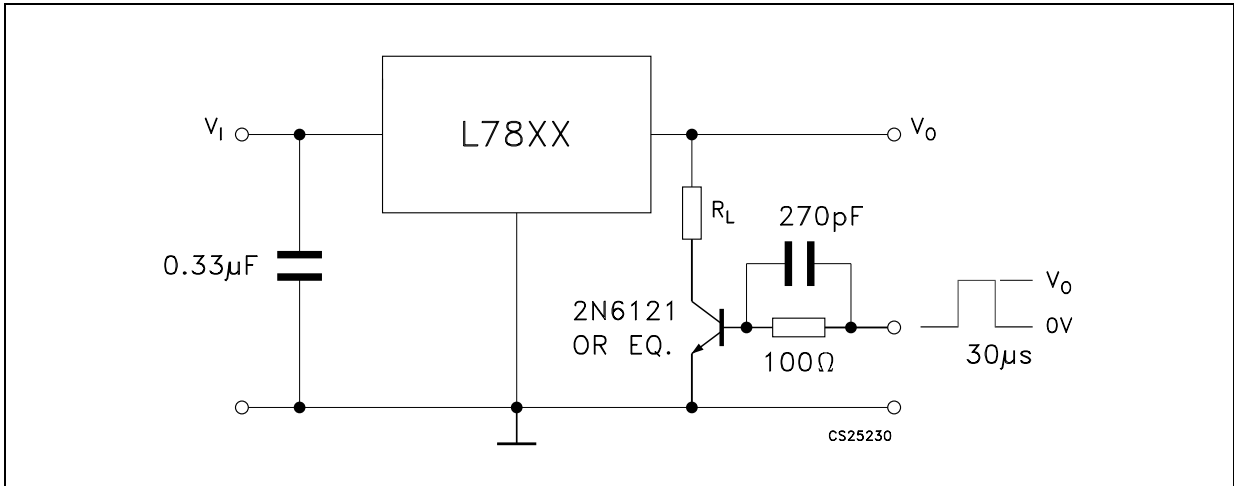
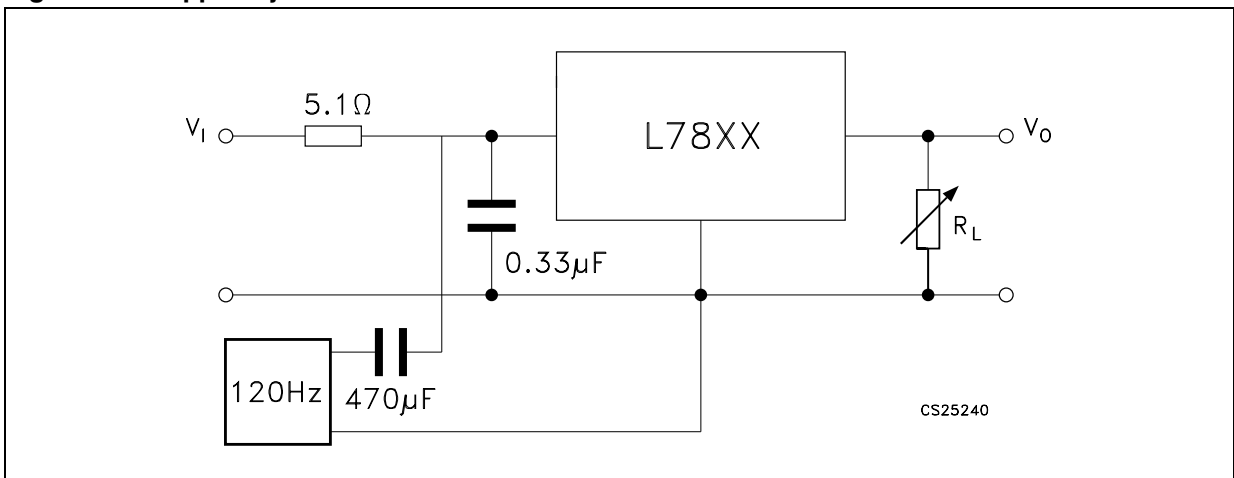

Figure 6. Ripple rejection



4 Electrical characteristics

Table 3. Electrical characteristics of L7805 (refer to the test circuits, $T_J = -55$ to 150°C , $V_I = 10\text{V}$, $I_O = 500\text{ mA}$, $C_I = 0.33\ \mu\text{F}$, $C_O = 0.1\ \mu\text{F}$ unless otherwise specified)

Symbol	Parameter	Test conditions	Min.	Typ.	Max.	Unit
V_O	Output voltage	$T_J = 25^\circ\text{C}$	4.8	5	5.2	V
V_O	Output voltage	$I_O = 5\text{mA to } 1\text{A}$, $P_O \leq 15\text{W}$ $V_I = 8$ to 20V	4.65	5	5.35	V
$\Delta V_O^{(1)}$	Line regulation	$V_I = 7$ to 25V , $T_J = 25^\circ\text{C}$		3	50	mV
		$V_I = 8$ to 12V , $T_J = 25^\circ\text{C}$		1	25	
$\Delta V_O^{(1)}$	Load regulation	$I_O = 5\text{ mA to } 1.5\text{A}$, $T_J = 25^\circ\text{C}$			100	mV
		$I_O = 250$ to 750mA , $T_J = 25^\circ\text{C}$			25	
I_d	Quiescent current	$T_J = 25^\circ\text{C}$			6	mA
ΔI_d	Quiescent current change	$I_O = 5\text{mA to } 1\text{A}$			0.5	mA
		$V_I = 8$ to 25 V			0.8	
$\Delta V_O/\Delta T$	Output voltage drift	$I_O = 5\text{mA}$		0.6		mV/ $^\circ\text{C}$
eN	Output noise voltage	$B = 10\text{Hz to } 100\text{KHz}$, $T_J = 25^\circ\text{C}$			40	$\mu\text{V}/V_O$
SVR	Supply voltage rejection	$V_I = 8$ to 18V , $f = 120\text{Hz}$	68			dB
V_d	Dropout voltage	$I_O = 1\text{A}$, $T_J = 25^\circ\text{C}$		2	2.5	V
R_O	Output resistance	$f = 1\text{ KHz}$		17		m Ω
I_{sc}	Short circuit current	$V_I = 35\text{V}$, $T_J = 25^\circ\text{C}$		0.75	1.2	A
I_{scp}	Short circuit peak current	$T_J = 25^\circ\text{C}$	1.3	2.2	3.3	A

1. Load and line regulation are specified at constant junction temperature. Changes in V_O due to heating effects must be taken into account separately. Pulse testing with low duty cycle is used.

Table 4. Electrical characteristics of L7806 (refer to the test circuits, $T_J = -55$ to 150°C , $V_I = 11\text{V}$, $I_O = 500\text{ mA}$, $C_I = 0.33\text{ }\mu\text{F}$, $C_O = 0.1\text{ }\mu\text{F}$ unless otherwise specified)

Symbol	Parameter	Test conditions	Min.	Typ.	Max.	Unit
V_O	Output voltage	$T_J = 25^\circ\text{C}$	5.75	6	6.25	V
V_O	Output voltage	$I_O = 5\text{mA to }1\text{A}$, $P_O \leq 15\text{W}$ $V_I = 9$ to 21V	5.65	6	6.35	V
$\Delta V_O^{(1)}$	Line regulation	$V_I = 8$ to 25V , $T_J = 25^\circ\text{C}$			60	mV
		$V_I = 9$ to 13V , $T_J = 25^\circ\text{C}$			30	
$\Delta V_O^{(1)}$	Load regulation	$I_O = 5\text{ mA to }1.5\text{A}$, $T_J = 25^\circ\text{C}$			100	mV
		$I_O = 250$ to 750mA , $T_J = 25^\circ\text{C}$			30	
I_d	Quiescent current	$T_J = 25^\circ\text{C}$			6	mA
ΔI_d	Quiescent current change	$I_O = 5\text{mA to }1\text{A}$			0.5	mA
		$V_I = 9$ to 25V			0.8	
$\Delta V_O/\Delta T$	Output voltage drift	$I_O = 5\text{mA}$		0.7		mV/ $^\circ\text{C}$
eN	Output noise voltage	$B = 10\text{Hz to }100\text{KHz}$, $T_J = 25^\circ\text{C}$			40	$\mu\text{V}/V_O$
SVR	Supply voltage rejection	$V_I = 9$ to 19V , $f = 120\text{Hz}$	65			dB
V_d	Dropout voltage	$I_O = 1\text{A}$, $T_J = 25^\circ\text{C}$		2	2.5	V
R_O	Output resistance	$f = 1\text{ KHz}$		19		m Ω
I_{sc}	Short circuit current	$V_I = 35\text{V}$, $T_J = 25^\circ\text{C}$		0.75	1.2	A
I_{scp}	Short circuit peak current	$T_J = 25^\circ\text{C}$	1.3	2.2	3.3	A

1. Load and line regulation are specified at constant junction temperature. Changes in V_O due to heating effects must be taken into account separately. Pulse testing with low duty cycle is used.

Table 5. Electrical characteristics of L7808 (refer to the test circuits, $T_J = -55$ to 150°C , $V_I = 14\text{V}$, $I_O = 500\text{ mA}$, $C_I = 0.33\ \mu\text{F}$, $C_O = 0.1\ \mu\text{F}$ unless otherwise specified)

Symbol	Parameter	Test conditions	Min.	Typ.	Max.	Unit
V_O	Output voltage	$T_J = 25^\circ\text{C}$	7.7	8	8.3	V
V_O	Output voltage	$I_O = 5\text{mA to } 1\text{A}$, $P_O \leq 15\text{W}$ $V_I = 11.5$ to 23V	7.6	8	8.4	V
$\Delta V_O^{(1)}$	Line regulation	$V_I = 10.5$ to 25V , $T_J = 25^\circ\text{C}$			80	mV
		$V_I = 11$ to 17V , $T_J = 25^\circ\text{C}$			40	
$\Delta V_O^{(1)}$	Load regulation	$I_O = 5\text{ mA to } 1.5\text{A}$, $T_J = 25^\circ\text{C}$			100	mV
		$I_O = 250$ to 750mA , $T_J = 25^\circ\text{C}$			40	
I_d	Quiescent current	$T_J = 25^\circ\text{C}$			6	mA
ΔI_d	Quiescent current change	$I_O = 5\text{mA to } 1\text{A}$			0.5	mA
		$V_I = 11.5$ to 25V			0.8	
$\Delta V_O/\Delta T$	Output voltage drift	$I_O = 5\text{mA}$		1		mV/ $^\circ\text{C}$
eN	Output noise voltage	$B = 10\text{Hz to } 100\text{KHz}$, $T_J = 25^\circ\text{C}$			40	$\mu\text{V}/V_O$
SVR	Supply voltage rejection	$V_I = 11.5$ to 21.5V , $f = 120\text{Hz}$	62			dB
V_d	Dropout voltage	$I_O = 1\text{A}$, $T_J = 25^\circ\text{C}$		2	2.5	V
R_O	Output resistance	$f = 1\text{ KHz}$		16		m Ω
I_{sc}	Short circuit current	$V_I = 35\text{V}$, $T_J = 25^\circ\text{C}$		0.75	1.2	A
I_{scp}	Short circuit peak current	$T_J = 25^\circ\text{C}$	1.3	2.2	3.3	A

1. Load and line regulation are specified at constant junction temperature. Changes in V_O due to heating effects must be taken into account separately. Pulse testing with low duty cycle is used.

Table 6. Electrical characteristics of L7812 (refer to the test circuits, $T_J = -55$ to 150°C , $V_I = 19\text{V}$, $I_O = 500\text{ mA}$, $C_I = 0.33\ \mu\text{F}$, $C_O = 0.1\ \mu\text{F}$ unless otherwise specified)

Symbol	Parameter	Test conditions	Min.	Typ.	Max.	Unit
V_O	Output voltage	$T_J = 25^\circ\text{C}$	11.5	12	12.5	V
V_O	Output voltage	$I_O = 5\text{mA to } 1\text{A}$, $P_O \leq 15\text{W}$ $V_I = 15.5$ to 27V	11.4	12	12.6	V
$\Delta V_O^{(1)}$	Line regulation	$V_I = 14.5$ to 30V , $T_J = 25^\circ\text{C}$			120	mV
		$V_I = 16$ to 22V , $T_J = 25^\circ\text{C}$			60	
$\Delta V_O^{(1)}$	Load regulation	$I_O = 5\text{ mA to } 1.5\text{A}$, $T_J = 25^\circ\text{C}$			100	mV
		$I_O = 250$ to 750mA , $T_J = 25^\circ\text{C}$			60	
I_d	Quiescent current	$T_J = 25^\circ\text{C}$			6	mA
ΔI_d	Quiescent current change	$I_O = 5\text{mA to } 1\text{A}$			0.5	mA
		$V_I = 15$ to 30V			0.8	
$\Delta V_O/\Delta T$	Output voltage drift	$I_O = 5\text{mA}$		1.5		mV/ $^\circ\text{C}$
eN	Output noise voltage	$B = 10\text{Hz to } 100\text{KHz}$, $T_J = 25^\circ\text{C}$			40	$\mu\text{V}/V_O$
SVR	Supply voltage rejection	$V_I = 15$ to 25V , $f = 120\text{Hz}$	61			dB
V_d	Dropout voltage	$I_O = 1\text{A}$, $T_J = 25^\circ\text{C}$		2	2.5	V
R_O	Output resistance	$f = 1\text{ KHz}$		18		m Ω
I_{sc}	Short circuit current	$V_I = 35\text{V}$, $T_J = 25^\circ\text{C}$		0.75	1.2	A
I_{scp}	Short circuit peak current	$T_J = 25^\circ\text{C}$	1.3	2.2	3.3	A

1. Load and line regulation are specified at constant junction temperature. Changes in V_O due to heating effects must be taken into account separately. Pulse testing with low duty cycle is used.

Table 7. Electrical characteristics of L7815 (refer to the test circuits, $T_J = -55$ to 150°C , $V_I = 23\text{V}$, $I_O = 500\text{ mA}$, $C_I = 0.33\ \mu\text{F}$, $C_O = 0.1\ \mu\text{F}$ unless otherwise specified)

Symbol	Parameter	Test conditions	Min.	Typ.	Max.	Unit
V_O	Output voltage	$T_J = 25^\circ\text{C}$	14.4	15	15.6	V
V_O	Output voltage	$I_O = 5\text{mA to } 1\text{A}$, $P_O \leq 15\text{W}$ $V_I = 18.5$ to 30V	14.25	15	15.75	V
$\Delta V_O^{(1)}$	Line regulation	$V_I = 17.5$ to 30V , $T_J = 25^\circ\text{C}$			150	mV
		$V_I = 20$ to 26V , $T_J = 25^\circ\text{C}$			75	
$\Delta V_O^{(1)}$	Load regulation	$I_O = 5\text{ mA to } 1.5\text{A}$, $T_J = 25^\circ\text{C}$			150	mV
		$I_O = 250$ to 750mA , $T_J = 25^\circ\text{C}$			75	
I_d	Quiescent current	$T_J = 25^\circ\text{C}$			6	mA
ΔI_d	Quiescent current change	$I_O = 5\text{mA to } 1\text{A}$			0.5	mA
		$V_I = 18.5$ to 30V			0.8	
$\Delta V_O/\Delta T$	Output voltage drift	$I_O = 5\text{mA}$		1.8		mV/ $^\circ\text{C}$
eN	Output noise voltage	$B = 10\text{Hz to } 100\text{KHz}$, $T_J = 25^\circ\text{C}$			40	$\mu\text{V}/V_O$
SVR	Supply voltage rejection	$V_I = 18.5$ to 28.5V , $f = 120\text{Hz}$	60			dB
V_d	Dropout voltage	$I_O = 1\text{A}$, $T_J = 25^\circ\text{C}$		2	2.5	V
R_O	Output resistance	$f = 1\text{ KHz}$		19		m Ω
I_{sc}	Short circuit current	$V_I = 35\text{V}$, $T_J = 25^\circ\text{C}$		0.75	1.2	A
I_{scp}	Short circuit peak current	$T_J = 25^\circ\text{C}$	1.3	2.2	3.3	A

1. Load and line regulation are specified at constant junction temperature. Changes in V_O due to heating effects must be taken into account separately. Pulse testing with low duty cycle is used.

Table 8. Electrical characteristics of L7818 (refer to the test circuits, $T_J = -55$ to 150°C , $V_I = 26\text{V}$, $I_O = 500\text{ mA}$, $C_I = 0.33\text{ }\mu\text{F}$, $C_O = 0.1\text{ }\mu\text{F}$ unless otherwise specified)

Symbol	Parameter	Test conditions	Min.	Typ.	Max.	Unit
V_O	Output voltage	$T_J = 25^\circ\text{C}$	17.3	18	18.7	V
V_O	Output voltage	$I_O = 5\text{mA to }1\text{A}$, $P_O \leq 15\text{W}$ $V_I = 22$ to 33V	17.1	18	18.9	V
$\Delta V_O^{(1)}$	Line regulation	$V_I = 21$ to 33V , $T_J = 25^\circ\text{C}$			180	mV
		$V_I = 24$ to 30V , $T_J = 25^\circ\text{C}$			90	
$\Delta V_O^{(1)}$	Load regulation	$I_O = 5\text{ mA to }1.5\text{A}$, $T_J = 25^\circ\text{C}$			180	mV
		$I_O = 250$ to 750mA , $T_J = 25^\circ\text{C}$			90	
I_d	Quiescent current	$T_J = 25^\circ\text{C}$			6	mA
ΔI_d	Quiescent current change	$I_O = 5\text{mA to }1\text{A}$			0.5	mA
		$V_I = 22$ to 33V			0.8	
$\Delta V_O/\Delta T$	Output voltage drift	$I_O = 5\text{mA}$		2.3		mV/ $^\circ\text{C}$
eN	Output noise voltage	$B = 10\text{Hz to }100\text{KHz}$, $T_J = 25^\circ\text{C}$			40	$\mu\text{V}/V_O$
SVR	Supply voltage rejection	$V_I = 22$ to 32V , $f = 120\text{Hz}$	59			dB
V_d	Dropout voltage	$I_O = 1\text{A}$, $T_J = 25^\circ\text{C}$		2	2.5	V
R_O	Output resistance	$f = 1\text{ KHz}$		22		m Ω
I_{sc}	Short circuit current	$V_I = 35\text{V}$, $T_J = 25^\circ\text{C}$		0.75	1.2	A
I_{scp}	Short circuit peak current	$T_J = 25^\circ\text{C}$	1.3	2.2	3.3	A

1. Load and line regulation are specified at constant junction temperature. Changes in V_O due to heating effects must be taken into account separately. Pulse testing with low duty cycle is used.

Table 9. Electrical characteristics of L7820 (refer to the test circuits, $T_J = -55$ to 150°C , $V_I = 28\text{V}$, $I_O = 500\text{ mA}$, $C_I = 0.33\ \mu\text{F}$, $C_O = 0.1\ \mu\text{F}$ unless otherwise specified)

Symbol	Parameter	Test conditions	Min.	Typ.	Max.	Unit
V_O	Output voltage	$T_J = 25^\circ\text{C}$	19.2	20	20.8	V
V_O	Output voltage	$I_O = 5\text{mA to } 1\text{A}$, $P_O \leq 15\text{W}$ $V_I = 24$ to 35V	19	20	21	V
$\Delta V_O^{(1)}$	Line regulation	$V_I = 22.5$ to 35V , $T_J = 25^\circ\text{C}$			200	mV
		$V_I = 26$ to 32V , $T_J = 25^\circ\text{C}$			100	
$\Delta V_O^{(1)}$	Load regulation	$I_O = 5\text{ mA to } 1.5\text{A}$, $T_J = 25^\circ\text{C}$			200	mV
		$I_O = 250$ to 750mA , $T_J = 25^\circ\text{C}$			100	
I_d	Quiescent current	$T_J = 25^\circ\text{C}$			6	mA
ΔI_d	Quiescent current change	$I_O = 5\text{mA to } 1\text{A}$			0.5	mA
		$V_I = 24$ to 35V			0.8	
$\Delta V_O/\Delta T$	Output voltage drift	$I_O = 5\text{mA}$		2.5		mV/ $^\circ\text{C}$
eN	Output noise voltage	$B = 10\text{Hz to } 100\text{KHz}$, $T_J = 25^\circ\text{C}$			40	$\mu\text{V}/V_O$
SVR	Supply voltage rejection	$V_I = 24$ to 35V , $f = 120\text{Hz}$	58			dB
V_d	Dropout voltage	$I_O = 1\text{A}$, $T_J = 25^\circ\text{C}$		2	2.5	V
R_O	Output resistance	$f = 1\text{ KHz}$		24		m Ω
I_{sc}	Short circuit current	$V_I = 35\text{V}$, $T_J = 25^\circ\text{C}$		0.75	1.2	A
I_{scp}	Short circuit peak current	$T_J = 25^\circ\text{C}$	1.3	2.2	3.3	A

1. Load and line regulation are specified at constant junction temperature. Changes in V_O due to heating effects must be taken into account separately. Pulse testing with low duty cycle is used.

Table 10. Electrical characteristics of L7824 (refer to the test circuits, $T_J = -55$ to 150°C , $V_I = 33\text{V}$, $I_O = 500\text{ mA}$, $C_I = 0.33\text{ }\mu\text{F}$, $C_O = 0.1\text{ }\mu\text{F}$ unless otherwise specified)

Symbol	Parameter	Test conditions	Min.	Typ.	Max.	Unit
V_O	Output voltage	$T_J = 25^\circ\text{C}$	23	24	25	V
V_O	Output voltage	$I_O = 5\text{mA to }1\text{A}$, $P_O \leq 15\text{W}$ $V_I = 28$ to 38V	22.8	24	25.2	V
$\Delta V_O^{(1)}$	Line regulation	$V_I = 27$ to 38V , $T_J = 25^\circ\text{C}$			240	mV
		$V_I = 30$ to 36V , $T_J = 25^\circ\text{C}$			120	
$\Delta V_O^{(1)}$	Load regulation	$I_O = 5\text{ mA to }1.5\text{A}$, $T_J = 25^\circ\text{C}$			240	mV
		$I_O = 250$ to 750mA , $T_J = 25^\circ\text{C}$			120	
I_d	Quiescent current	$T_J = 25^\circ\text{C}$			6	mA
ΔI_d	Quiescent current change	$I_O = 5\text{mA to }1\text{A}$			0.5	mA
		$V_I = 28$ to 38V			0.8	
$\Delta V_O/\Delta T$	Output voltage drift	$I_O = 5\text{mA}$		3		mV/ $^\circ\text{C}$
eN	Output noise voltage	$B = 10\text{Hz to }100\text{KHz}$, $T_J = 25^\circ\text{C}$			40	$\mu\text{V}/V_O$
SVR	Supply voltage rejection	$V_I = 28$ to 38V , $f = 120\text{Hz}$	56			dB
V_d	Dropout voltage	$I_O = 1\text{A}$, $T_J = 25^\circ\text{C}$		2	2.5	V
R_O	Output resistance	$f = 1\text{ KHz}$		28		m Ω
I_{sc}	Short circuit current	$V_I = 35\text{V}$, $T_J = 25^\circ\text{C}$		0.75	1.2	A
I_{scp}	Short circuit peak current	$T_J = 25^\circ\text{C}$	1.3	2.2	3.3	A

1. Load and line regulation are specified at constant junction temperature. Changes in V_O due to heating effects must be taken into account separately. Pulse testing with low duty cycle is used.

Table 11. Electrical characteristics of L7805C (refer to the test circuits, $T_J = -55$ to 150°C , $V_I = 10\text{V}$, $I_O = 500\text{ mA}$, $C_I = 0.33\ \mu\text{F}$, $C_O = 0.1\ \mu\text{F}$ unless otherwise specified)

Symbol	Parameter	Test conditions	Min.	Typ.	Max.	Unit
V_O	Output voltage	$T_J = 25^\circ\text{C}$	4.8	5	5.2	V
V_O	Output voltage	$I_O = 5\text{mA to } 1\text{A}$, $P_O \leq 15\text{W}$ $V_I = 7$ to 20V	4.75	5	5.25	V
$\Delta V_O^{(1)}$	Line regulation	$V_I = 7$ to 25V , $T_J = 25^\circ\text{C}$		3	100	mV
		$V_I = 8$ to 12V , $T_J = 25^\circ\text{C}$		1	50	
$\Delta V_O^{(1)}$	Load regulation	$I_O = 5\text{ mA to } 1.5\text{A}$, $T_J = 25^\circ\text{C}$			100	mV
		$I_O = 250$ to 750mA , $T_J = 25^\circ\text{C}$			50	
I_d	Quiescent current	$T_J = 25^\circ\text{C}$			8	mA
ΔI_d	Quiescent current change	$I_O = 5\text{mA to } 1\text{A}$			0.5	mA
		$V_I = 7$ to 25 V			0.8	
$\Delta V_O/\Delta T$	Output voltage drift	$I_O = 5\text{mA}$		-1.1		mV/ $^\circ\text{C}$
eN	Output noise voltage	$B = 10\text{Hz to } 100\text{KHz}$, $T_J = 25^\circ\text{C}$		40		$\mu\text{V}/V_O$
SVR	Supply voltage rejection	$V_I = 8$ to 18V , $f = 120\text{Hz}$	62			dB
V_d	Dropout voltage	$I_O = 1\text{A}$, $T_J = 25^\circ\text{C}$		2		V
R_O	Output resistance	$f = 1\text{ KHz}$		17		m Ω
I_{sc}	Short circuit current	$V_I = 35\text{V}$, $T_J = 25^\circ\text{C}$		0.75		A
I_{scp}	Short circuit peak current	$T_J = 25^\circ\text{C}$		2.2		A

1. Load and line regulation are specified at constant junction temperature. Changes in V_O due to heating effects must be taken into account separately. Pulse testing with low duty cycle is used.

Table 12. Electrical characteristics of L7852C (refer to the test circuits, $T_J = -55$ to 150°C , $V_I = 10\text{V}$, $I_O = 500\text{ mA}$, $C_I = 0.33\ \mu\text{F}$, $C_O = 0.1\ \mu\text{F}$ unless otherwise specified)

Symbol	Parameter	Test conditions	Min.	Typ.	Max.	Unit
V_O	Output voltage	$T_J = 25^\circ\text{C}$	5.0	5.2	5.4	V
V_O	Output voltage	$I_O = 5\text{mA to } 1\text{A}$, $P_O \leq 15\text{W}$ $V_I = 8$ to 20V	4.95	5.2	5.45	V
$\Delta V_O^{(1)}$	Line regulation	$V_I = 7$ to 25V , $T_J = 25^\circ\text{C}$		3	105	mV
		$V_I = 8$ to 12V , $T_J = 25^\circ\text{C}$		1	52	
$\Delta V_O^{(1)}$	Load regulation	$I_O = 5\text{ mA to } 1.5\text{A}$, $T_J = 25^\circ\text{C}$			105	mV
		$I_O = 250$ to 750mA , $T_J = 25^\circ\text{C}$			52	
I_d	Quiescent current	$T_J = 25^\circ\text{C}$			8	mA
ΔI_d	Quiescent current change	$I_O = 5\text{mA to } 1\text{A}$			0.5	mA
		$V_I = 7$ to 25 V			1.3	
$\Delta V_O/\Delta T$	Output voltage drift	$I_O = 5\text{mA}$		-1		mV/ $^\circ\text{C}$
eN	Output noise voltage	$B = 10\text{Hz to } 100\text{KHz}$, $T_J = 25^\circ\text{C}$		42		$\mu\text{V}/V_O$
SVR	Supply voltage rejection	$V_I = 8$ to 18V , $f = 120\text{Hz}$	61			dB
V_d	Dropout voltage	$I_O = 1\text{A}$, $T_J = 25^\circ\text{C}$		2		V
R_O	Output resistance	$f = 1\text{ KHz}$		17		m Ω
I_{sc}	Short circuit current	$V_I = 35\text{V}$, $T_J = 25^\circ\text{C}$		0.75		A
I_{scp}	Short circuit peak current	$T_J = 25^\circ\text{C}$		2.2		A

1. Load and line regulation are specified at constant junction temperature. Changes in V_O due to heating effects must be taken into account separately. Pulse testing with low duty cycle is used.

Table 13. Electrical characteristics of L7806C (refer to the test circuits, $T_J = -55$ to 150°C , $V_I = 11\text{V}$, $I_O = 500\text{ mA}$, $C_I = 0.33\ \mu\text{F}$, $C_O = 0.1\ \mu\text{F}$ unless otherwise specified)

Symbol	Parameter	Test conditions	Min.	Typ.	Max.	Unit
V_O	Output voltage	$T_J = 25^\circ\text{C}$	5.75	6	6.25	V
V_O	Output voltage	$I_O = 5\text{mA to } 1\text{A}$, $P_O \leq 15\text{W}$ $V_I = 8$ to 21V	5.7	6	6.3	V
$\Delta V_O^{(1)}$	Line regulation	$V_I = 8$ to 25V , $T_J = 25^\circ\text{C}$			120	mV
		$V_I = 9$ to 13V , $T_J = 25^\circ\text{C}$			60	
$\Delta V_O^{(1)}$	Load regulation	$I_O = 5\text{ mA to } 1.5\text{A}$, $T_J = 25^\circ\text{C}$			120	mV
		$I_O = 250$ to 750mA , $T_J = 25^\circ\text{C}$			60	
I_d	Quiescent current	$T_J = 25^\circ\text{C}$			8	mA
ΔI_d	Quiescent current change	$I_O = 5\text{mA to } 1\text{A}$			0.5	mA
		$V_I = 8$ to 25V			1.3	
$\Delta V_O/\Delta T$	Output voltage drift	$I_O = 5\text{mA}$		-0.8		mV/ $^\circ\text{C}$
eN	Output noise voltage	$B = 10\text{Hz to } 100\text{KHz}$, $T_J = 25^\circ\text{C}$		45		$\mu\text{V}/V_O$
SVR	Supply voltage rejection	$V_I = 9$ to 19V , $f = 120\text{Hz}$	59			dB
V_d	Dropout voltage	$I_O = 1\text{A}$, $T_J = 25^\circ\text{C}$		2		V
R_O	Output resistance	$f = 1\text{ KHz}$		19		m Ω
I_{sc}	Short circuit current	$V_I = 35\text{V}$, $T_J = 25^\circ\text{C}$		0.55		A
I_{scp}	Short circuit peak current	$T_J = 25^\circ\text{C}$		2.2		A

1. Load and line regulation are specified at constant junction temperature. Changes in V_O due to heating effects must be taken into account separately. Pulse testing with low duty cycle is used.

Table 14. Electrical characteristics of L7808C (refer to the test circuits, $T_J = -55$ to 150°C , $V_I = 14\text{V}$, $I_O = 500\text{ mA}$, $C_I = 0.33\text{ }\mu\text{F}$, $C_O = 0.1\text{ }\mu\text{F}$ unless otherwise specified)

Symbol	Parameter	Test conditions	Min.	Typ.	Max.	Unit
V_O	Output voltage	$T_J = 25^\circ\text{C}$	7.7	8	8.3	V
V_O	Output voltage	$I_O = 5\text{mA to }1\text{A}$, $P_O \leq 15\text{W}$ $V_I = 10.5$ to 25V	7.6	8	8.4	V
$\Delta V_O^{(1)}$	Line regulation	$V_I = 10.5$ to 25V , $T_J = 25^\circ\text{C}$			160	mV
		$V_I = 11$ to 17V , $T_J = 25^\circ\text{C}$			80	
$\Delta V_O^{(1)}$	Load regulation	$I_O = 5\text{ mA to }1.5\text{A}$, $T_J = 25^\circ\text{C}$			160	mV
		$I_O = 250$ to 750mA , $T_J = 25^\circ\text{C}$			80	
I_d	Quiescent current	$T_J = 25^\circ\text{C}$			8	mA
ΔI_d	Quiescent current change	$I_O = 5\text{mA to }1\text{A}$			0.5	mA
		$V_I = 10.5$ to 25V			1	
$\Delta V_O/\Delta T$	Output voltage drift	$I_O = 5\text{mA}$		-0.8		mV/ $^\circ\text{C}$
eN	Output noise voltage	$B = 10\text{Hz to }100\text{KHz}$, $T_J = 25^\circ\text{C}$		52		$\mu\text{V}/V_O$
SVR	Supply voltage rejection	$V_I = 11.5$ to 21.5V , $f = 120\text{Hz}$	56			dB
V_d	Dropout voltage	$I_O = 1\text{A}$, $T_J = 25^\circ\text{C}$		2		V
R_O	Output resistance	$f = 1\text{ KHz}$		16		m Ω
I_{sc}	Short circuit current	$V_I = 35\text{V}$, $T_J = 25^\circ\text{C}$		0.45		A
I_{scp}	Short circuit peak current	$T_J = 25^\circ\text{C}$		2.2		A

1. Load and line regulation are specified at constant junction temperature. Changes in V_O due to heating effects must be taken into account separately. Pulse testing with low duty cycle is used.

Table 15. Electrical characteristics of L7885C (refer to the test circuits, $T_J = -55$ to 150°C , $V_I = 14.5\text{V}$, $I_O = 500\text{ mA}$, $C_I = 0.33\text{ }\mu\text{F}$, $C_O = 0.1\text{ }\mu\text{F}$ unless otherwise specified)

Symbol	Parameter	Test conditions	Min.	Typ.	Max.	Unit
V_O	Output voltage	$T_J = 25^\circ\text{C}$	8.2	8.5	8.8	V
V_O	Output voltage	$I_O = 5\text{mA to }1\text{A}$, $P_O \leq 15\text{W}$ $V_I = 11$ to 26V	8.1	8.5	8.9	V
$\Delta V_O^{(1)}$	Line regulation	$V_I = 11$ to 27V , $T_J = 25^\circ\text{C}$			160	mV
		$V_I = 11.5$ to 17.5V , $T_J = 25^\circ\text{C}$			80	
$\Delta V_O^{(1)}$	Load regulation	$I_O = 5\text{ mA to }1.5\text{A}$, $T_J = 25^\circ\text{C}$			160	mV
		$I_O = 250$ to 750mA , $T_J = 25^\circ\text{C}$			80	
I_d	Quiescent current	$T_J = 25^\circ\text{C}$			8	mA
ΔI_d	Quiescent current change	$I_O = 5\text{mA to }1\text{A}$			0.5	mA
		$V_I = 11$ to 27V			1	
$\Delta V_O/\Delta T$	Output voltage drift	$I_O = 5\text{mA}$		-0.8		mV/ $^\circ\text{C}$
eN	Output noise voltage	$B = 10\text{Hz to }100\text{kHz}$, $T_J = 25^\circ\text{C}$		55		$\mu\text{V}/V_O$
SVR	Supply voltage rejection	$V_I = 12$ to 22V , $f = 120\text{Hz}$	56			dB
V_d	Dropout voltage	$I_O = 1\text{A}$, $T_J = 25^\circ\text{C}$		2		V
R_O	Output resistance	$f = 1\text{ KHz}$		16		m Ω
I_{sc}	Short circuit current	$V_I = 35\text{V}$, $T_J = 25^\circ\text{C}$		0.45		A
I_{scp}	Short circuit peak current	$T_J = 25^\circ\text{C}$		2.2		A

1. Load and line regulation are specified at constant junction temperature. Changes in V_O due to heating effects must be taken into account separately. Pulse testing with low duty cycle is used.

Table 16. Electrical characteristics of L7809C (refer to the test circuits, $T_J = -55$ to 150°C , $V_I = 15\text{V}$, $I_O = 500\text{ mA}$, $C_I = 0.33\text{ }\mu\text{F}$, $C_O = 0.1\text{ }\mu\text{F}$ unless otherwise specified)

Symbol	Parameter	Test conditions	Min.	Typ.	Max.	Unit
V_O	Output voltage	$T_J = 25^\circ\text{C}$	8.64	9	9.36	V
V_O	Output voltage	$I_O = 5\text{mA to } 1\text{A}$, $P_O \leq 15\text{W}$ $V_I = 11.5$ to 26V	8.55	9	9.45	V
$\Delta V_O^{(1)}$	Line regulation	$V_I = 11.5$ to 26V , $T_J = 25^\circ\text{C}$			180	mV
		$V_I = 12$ to 18V , $T_J = 25^\circ\text{C}$			90	
$\Delta V_O^{(1)}$	Load regulation	$I_O = 5\text{ mA to } 1.5\text{A}$, $T_J = 25^\circ\text{C}$			180	mV
		$I_O = 250$ to 750mA , $T_J = 25^\circ\text{C}$			90	
I_d	Quiescent current	$T_J = 25^\circ\text{C}$			8	mA
ΔI_d	Quiescent current change	$I_O = 5\text{mA to } 1\text{A}$			0.5	mA
		$V_I = 11.5$ to 26V			1	
$\Delta V_O/\Delta T$	Output voltage drift	$I_O = 5\text{mA}$		-1		mV/ $^\circ\text{C}$
eN	Output noise voltage	$B = 10\text{Hz to } 100\text{kHz}$, $T_J = 25^\circ\text{C}$		70		$\mu\text{V}/V_O$
SVR	Supply voltage rejection	$V_I = 12$ to 23V , $f = 120\text{Hz}$	55			dB
V_d	Dropout voltage	$I_O = 1\text{A}$, $T_J = 25^\circ\text{C}$		2		V
R_O	Output resistance	$f = 1\text{ KHz}$		17		m Ω
I_{sc}	Short circuit current	$V_I = 35\text{V}$, $T_J = 25^\circ\text{C}$		0.40		A
I_{scp}	Short circuit peak current	$T_J = 25^\circ\text{C}$		2.2		A

1. Load and line regulation are specified at constant junction temperature. Changes in V_O due to heating effects must be taken into account separately. Pulse testing with low duty cycle is used.

Table 17. Electrical characteristics of L7810C (refer to the test circuits, $T_J = -55$ to 150°C , $V_I = 15\text{V}$, $I_O = 500\text{ mA}$, $C_I = 0.33\ \mu\text{F}$, $C_O = 0.1\ \mu\text{F}$ unless otherwise specified)

Symbol	Parameter	Test conditions	Min.	Typ.	Max.	Unit
V_O	Output voltage	$T_J = 25^\circ\text{C}$	9.6	10	10.4	V
V_O	Output voltage	$I_O = 5\text{mA to } 1\text{A}$, $P_O \leq 15\text{W}$ $V_I = 12.5$ to 26V	9.5	10	10.5	V
$\Delta V_O^{(1)}$	Line regulation	$V_I = 12.5$ to 26V , $T_J = 25^\circ\text{C}$			200	mV
		$V_I = 13.5$ to 19V , $T_J = 25^\circ\text{C}$			100	
$\Delta V_O^{(1)}$	Load regulation	$I_O = 5\text{ mA to } 1.5\text{A}$, $T_J = 25^\circ\text{C}$			200	mV
		$I_O = 250$ to 750mA , $T_J = 25^\circ\text{C}$			100	
I_d	Quiescent current	$T_J = 25^\circ\text{C}$			8	mA
ΔI_d	Quiescent current change	$I_O = 5\text{mA to } 1\text{A}$			0.5	mA
		$V_I = 12.5$ to 26V			1	
$\Delta V_O/\Delta T$	Output voltage drift	$I_O = 5\text{mA}$		-1		mV/ $^\circ\text{C}$
eN	Output noise voltage	$B = 10\text{Hz to } 100\text{KHz}$, $T_J = 25^\circ\text{C}$		70		$\mu\text{V}/V_O$
SVR	Supply voltage rejection	$V_I = 13$ to 23V , $f = 120\text{Hz}$	55			dB
V_d	Dropout voltage	$I_O = 1\text{A}$, $T_J = 25^\circ\text{C}$		2		V
R_O	Output resistance	$f = 1\text{ KHz}$		17		m Ω
I_{sc}	Short circuit current	$V_I = 35\text{V}$, $T_J = 25^\circ\text{C}$		0.40		A
I_{scp}	Short circuit peak current	$T_J = 25^\circ\text{C}$		2.2		A

1. Load and line regulation are specified at constant junction temperature. Changes in V_O due to heating effects must be taken into account separately. Pulse testing with low duty cycle is used.

Table 18. Electrical characteristics of L7812C (refer to the test circuits, $T_J = -55$ to 150°C , $V_I = 19\text{V}$, $I_O = 500\text{ mA}$, $C_I = 0.33\text{ }\mu\text{F}$, $C_O = 0.1\text{ }\mu\text{F}$ unless otherwise specified)

Symbol	Parameter	Test conditions	Min.	Typ.	Max.	Unit
V_O	Output voltage	$T_J = 25^\circ\text{C}$	11.5	12	12.5	V
V_O	Output voltage	$I_O = 5\text{mA to }1\text{A}$, $P_O \leq 15\text{W}$ $V_I = 14.5$ to 27V	11.4	12	12.6	V
$\Delta V_O^{(1)}$	Line regulation	$V_I = 14.5$ to 30V , $T_J = 25^\circ\text{C}$			240	mV
		$V_I = 16$ to 22V , $T_J = 25^\circ\text{C}$			120	
$\Delta V_O^{(1)}$	Load regulation	$I_O = 5\text{ mA to }1.5\text{A}$, $T_J = 25^\circ\text{C}$			240	mV
		$I_O = 250$ to 750mA , $T_J = 25^\circ\text{C}$			120	
I_d	Quiescent current	$T_J = 25^\circ\text{C}$			8	mA
ΔI_d	Quiescent current change	$I_O = 5\text{mA to }1\text{A}$			0.5	mA
		$V_I = 14.5$ to 30V			1	
$\Delta V_O/\Delta T$	Output voltage drift	$I_O = 5\text{mA}$		-1		mV/ $^\circ\text{C}$
eN	Output noise voltage	$B = 10\text{Hz to }100\text{kHz}$, $T_J = 25^\circ\text{C}$		75		$\mu\text{V}/V_O$
SVR	Supply voltage rejection	$V_I = 15$ to 25V , $f = 120\text{Hz}$	55			dB
V_d	Dropout voltage	$I_O = 1\text{A}$, $T_J = 25^\circ\text{C}$		2		V
R_O	Output resistance	$f = 1\text{ KHz}$		18		m Ω
I_{sc}	Short circuit current	$V_I = 35\text{V}$, $T_J = 25^\circ\text{C}$		0.35		A
I_{scp}	Short circuit peak current	$T_J = 25^\circ\text{C}$		2.2		A

1. Load and line regulation are specified at constant junction temperature. Changes in V_O due to heating effects must be taken into account separately. Pulse testing with low duty cycle is used.

Table 19. Electrical characteristics of L7815C (refer to the test circuits, $T_J = -55$ to 150°C , $V_I = 23\text{V}$, $I_O = 500\text{ mA}$, $C_I = 0.33\ \mu\text{F}$, $C_O = 0.1\ \mu\text{F}$ unless otherwise specified)

Symbol	Parameter	Test conditions	Min.	Typ.	Max.	Unit
V_O	Output voltage	$T_J = 25^\circ\text{C}$	14.5	15	15.6	V
V_O	Output voltage	$I_O = 5\text{mA to } 1\text{A}$, $P_O \leq 15\text{W}$ $V_I = 17.5$ to 30V	14.25	15	15.75	V
$\Delta V_O^{(1)}$	Line regulation	$V_I = 17.5$ to 30V , $T_J = 25^\circ\text{C}$			300	mV
		$V_I = 20$ to 26V , $T_J = 25^\circ\text{C}$			150	
$\Delta V_O^{(1)}$	Load regulation	$I_O = 5\text{ mA to } 1.5\text{A}$, $T_J = 25^\circ\text{C}$			300	mV
		$I_O = 250$ to 750mA , $T_J = 25^\circ\text{C}$			150	
I_d	Quiescent current	$T_J = 25^\circ\text{C}$			8	mA
ΔI_d	Quiescent current change	$I_O = 5\text{mA to } 1\text{A}$			0.5	mA
		$V_I = 17.5$ to 30V			1	
$\Delta V_O/\Delta T$	Output voltage drift	$I_O = 5\text{mA}$		-1		mV/ $^\circ\text{C}$
eN	Output noise voltage	$B = 10\text{Hz to } 100\text{KHz}$, $T_J = 25^\circ\text{C}$		90		$\mu\text{V}/V_O$
SVR	Supply voltage rejection	$V_I = 18.5$ to 28.5V , $f = 120\text{Hz}$	54			dB
V_d	Dropout voltage	$I_O = 1\text{A}$, $T_J = 25^\circ\text{C}$		2		V
R_O	Output resistance	$f = 1\text{ KHz}$		19		m Ω
I_{sc}	Short circuit current	$V_I = 35\text{V}$, $T_J = 25^\circ\text{C}$		0.23		A
I_{scp}	Short circuit peak current	$T_J = 25^\circ\text{C}$		2.2		A

1. Load and line regulation are specified at constant junction temperature. Changes in V_O due to heating effects must be taken into account separately. Pulse testing with low duty cycle is used.

Table 20. Electrical characteristics of L7818C (refer to the test circuits, $T_J = -55$ to 150°C , $V_I = 26\text{V}$, $I_O = 500\text{ mA}$, $C_I = 0.33\text{ }\mu\text{F}$, $C_O = 0.1\text{ }\mu\text{F}$ unless otherwise specified)

Symbol	Parameter	Test conditions	Min.	Typ.	Max.	Unit
V_O	Output voltage	$T_J = 25^\circ\text{C}$	17.3	18	18.7	V
V_O	Output voltage	$I_O = 5\text{mA to } 1\text{A}$, $P_O \leq 15\text{W}$ $V_I = 21$ to 33V	17.1	18	18.9	V
$\Delta V_O^{(1)}$	Line regulation	$V_I = 21$ to 33V , $T_J = 25^\circ\text{C}$			360	mV
		$V_I = 24$ to 30V , $T_J = 25^\circ\text{C}$			180	
$\Delta V_O^{(1)}$	Load regulation	$I_O = 5\text{ mA to } 1.5\text{A}$, $T_J = 25^\circ\text{C}$			360	mV
		$I_O = 250$ to 750mA , $T_J = 25^\circ\text{C}$			180	
I_d	Quiescent current	$T_J = 25^\circ\text{C}$			8	mA
ΔI_d	Quiescent current change	$I_O = 5\text{mA to } 1\text{A}$			0.5	mA
		$V_I = 21$ to 33V			1	
$\Delta V_O/\Delta T$	Output voltage drift	$I_O = 5\text{mA}$		-1		mV/ $^\circ\text{C}$
eN	Output noise voltage	$B = 10\text{Hz to } 100\text{kHz}$, $T_J = 25^\circ\text{C}$		110		$\mu\text{V}/V_O$
SVR	Supply voltage rejection	$V_I = 22$ to 32V , $f = 120\text{Hz}$	53			dB
V_d	Dropout voltage	$I_O = 1\text{A}$, $T_J = 25^\circ\text{C}$		2		V
R_O	Output resistance	$f = 1\text{ KHz}$		22		m Ω
I_{sc}	Short circuit current	$V_I = 35\text{V}$, $T_J = 25^\circ\text{C}$		0.20		A
I_{scp}	Short circuit peak current	$T_J = 25^\circ\text{C}$		2.1		A

1. Load and line regulation are specified at constant junction temperature. Changes in V_O due to heating effects must be taken into account separately. Pulse testing with low duty cycle is used.

Table 21. Electrical characteristics of L7820C (refer to the test circuits, $T_J = -55$ to 150°C , $V_I = 28\text{V}$, $I_O = 500\text{ mA}$, $C_I = 0.33\text{ }\mu\text{F}$, $C_O = 0.1\text{ }\mu\text{F}$ unless otherwise specified)

Symbol	Parameter	Test conditions	Min.	Typ.	Max.	Unit
V_O	Output voltage	$T_J = 25^\circ\text{C}$	19.2	20	20.8	V
V_O	Output voltage	$I_O = 5\text{mA to }1\text{A}$, $P_O \leq 15\text{W}$ $V_I = 23$ to 35V	19	20	21	V
$\Delta V_O^{(1)}$	Line regulation	$V_I = 22.5$ to 35V , $T_J = 25^\circ\text{C}$			400	mV
		$V_I = 26$ to 32V , $T_J = 25^\circ\text{C}$			200	
$\Delta V_O^{(1)}$	Load regulation	$I_O = 5\text{ mA to }1.5\text{A}$, $T_J = 25^\circ\text{C}$			400	mV
		$I_O = 250$ to 750mA , $T_J = 25^\circ\text{C}$			200	
I_d	Quiescent current	$T_J = 25^\circ\text{C}$			8	mA
ΔI_d	Quiescent current change	$I_O = 5\text{mA to }1\text{A}$			0.5	mA
		$V_I = 23$ to 35V			1	
$\Delta V_O/\Delta T$	Output voltage drift	$I_O = 5\text{mA}$		-1		mV/ $^\circ\text{C}$
eN	Output noise voltage	$B = 10\text{Hz to }100\text{KHz}$, $T_J = 25^\circ\text{C}$		150		$\mu\text{V}/V_O$
SVR	Supply voltage rejection	$V_I = 24$ to 35V , $f = 120\text{Hz}$	52			dB
V_d	Dropout voltage	$I_O = 1\text{A}$, $T_J = 25^\circ\text{C}$		2		V
R_O	Output resistance	$f = 1\text{ KHz}$		24		m Ω
I_{sc}	Short circuit current	$V_I = 35\text{V}$, $T_J = 25^\circ\text{C}$		0.18		A
I_{scp}	Short circuit peak current	$T_J = 25^\circ\text{C}$		2.1		A

1. Load and line regulation are specified at constant junction temperature. Changes in V_O due to heating effects must be taken into account separately. Pulse testing with low duty cycle is used.

Table 22. Electrical characteristics of L7824C (refer to the test circuits, $T_J = -55$ to 150°C , $V_I = 33\text{V}$, $I_O = 500\text{ mA}$, $C_I = 0.33\text{ }\mu\text{F}$, $C_O = 0.1\text{ }\mu\text{F}$ unless otherwise specified)

Symbol	Parameter	Test conditions	Min.	Typ.	Max.	Unit
V_O	Output voltage	$T_J = 25^\circ\text{C}$	23	24	25	V
V_O	Output voltage	$I_O = 5\text{mA to } 1\text{A}$, $P_O \leq 15\text{W}$ $V_I = 27$ to 38V	22.8	24	25.2	V
$\Delta V_O^{(1)}$	Line regulation	$V_I = 27$ to 38V , $T_J = 25^\circ\text{C}$			480	mV
		$V_I = 30$ to 36V , $T_J = 25^\circ\text{C}$			240	
$\Delta V_O^{(1)}$	Load regulation	$I_O = 5\text{ mA to } 1.5\text{A}$, $T_J = 25^\circ\text{C}$			480	mV
		$I_O = 250$ to 750mA , $T_J = 25^\circ\text{C}$			240	
I_d	Quiescent current	$T_J = 25^\circ\text{C}$			8	mA
ΔI_d	Quiescent current change	$I_O = 5\text{mA to } 1\text{A}$			0.5	mA
		$V_I = 27$ to 38V			1	
$\Delta V_O/\Delta T$	Output voltage drift	$I_O = 5\text{mA}$		-1.5		mV/ $^\circ\text{C}$
eN	Output noise voltage	$B = 10\text{Hz to } 100\text{kHz}$, $T_J = 25^\circ\text{C}$		170		$\mu\text{V}/V_O$
SVR	Supply voltage rejection	$V_I = 28$ to 38V , $f = 120\text{Hz}$	50			dB
V_d	Dropout voltage	$I_O = 1\text{A}$, $T_J = 25^\circ\text{C}$		2		V
R_O	Output resistance	$f = 1\text{ KHz}$		28		m Ω
I_{sc}	Short circuit current	$V_I = 35\text{V}$, $T_J = 25^\circ\text{C}$		0.15		A
I_{scp}	Short circuit peak current	$T_J = 25^\circ\text{C}$		2.1		A

1. Load and line regulation are specified at constant junction temperature. Changes in V_O due to heating effects must be taken into account separately. Pulse testing with low duty cycle is used.

5 Typical performance

Figure 7. Dropout voltage vs junction temperature

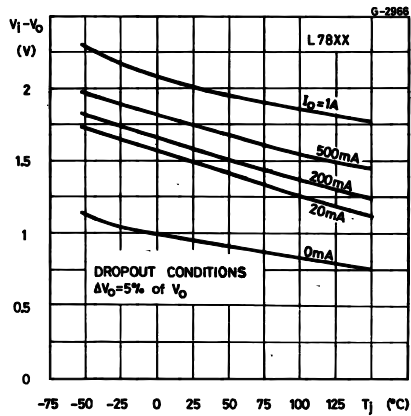

Figure 8. Peak output current vs input/output differential voltage

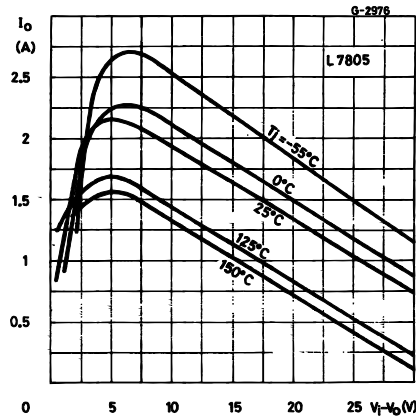

Figure 9. Supply voltage rejection vs frequency

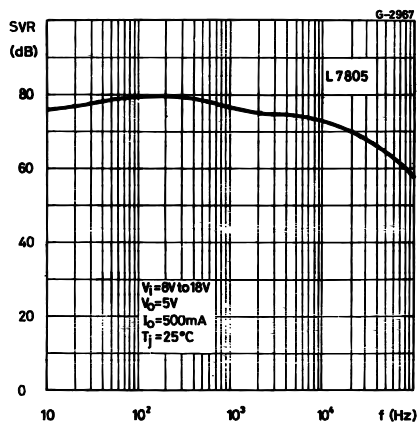

Figure 10. Output voltage vs junction temperature

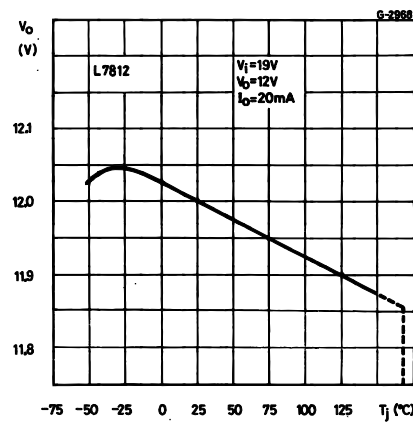

Figure 11. Output impedance vs frequency

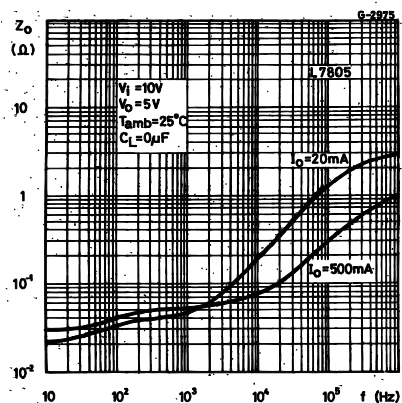

Figure 12. Quiescent current vs junction temperature

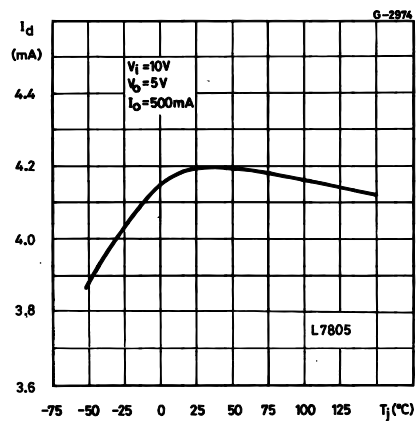

Figure 13. Load transient response

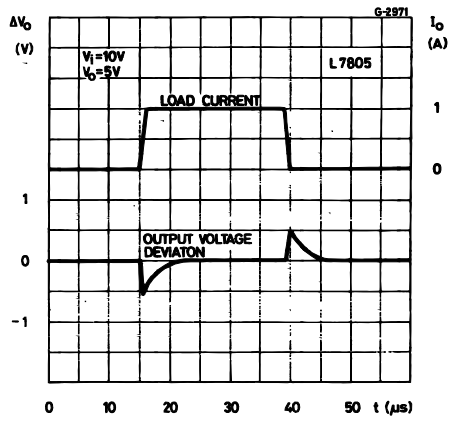

Figure 14. Line transient response

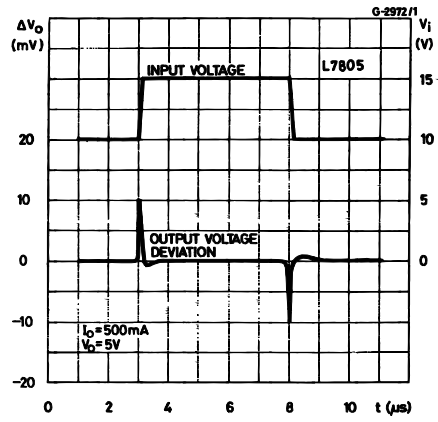

Figure 15. Quiescent current vs input voltage

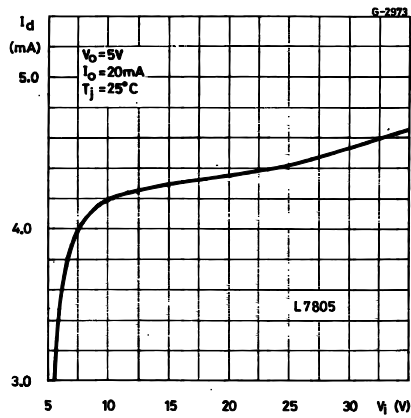
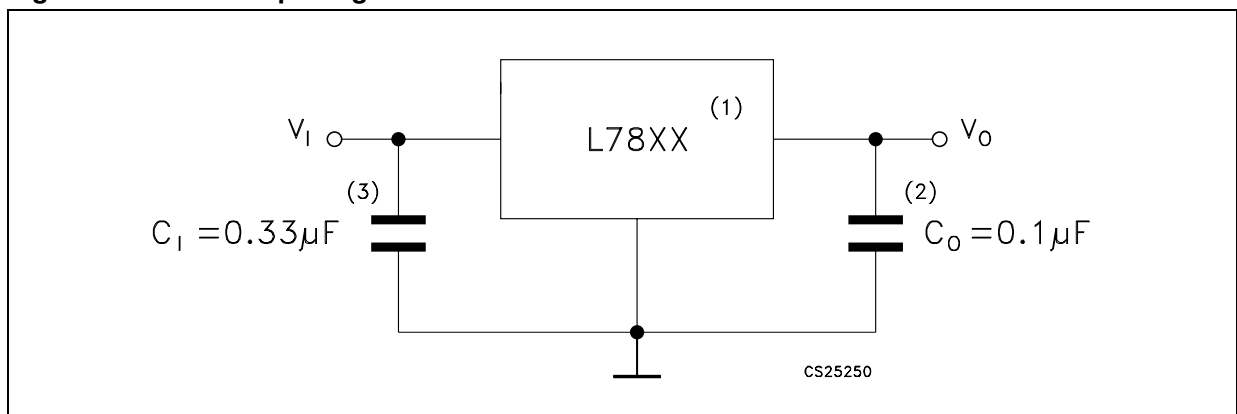

Figure 16. Fixed output regulator



1. To specify an output voltage, substitute voltage value for "XX".
2. Although no output capacitor is need for stability, it does improve transient response.
3. Required if regulator is locate an appreciable distance from power supply filter.

Figure 17. Current regulator

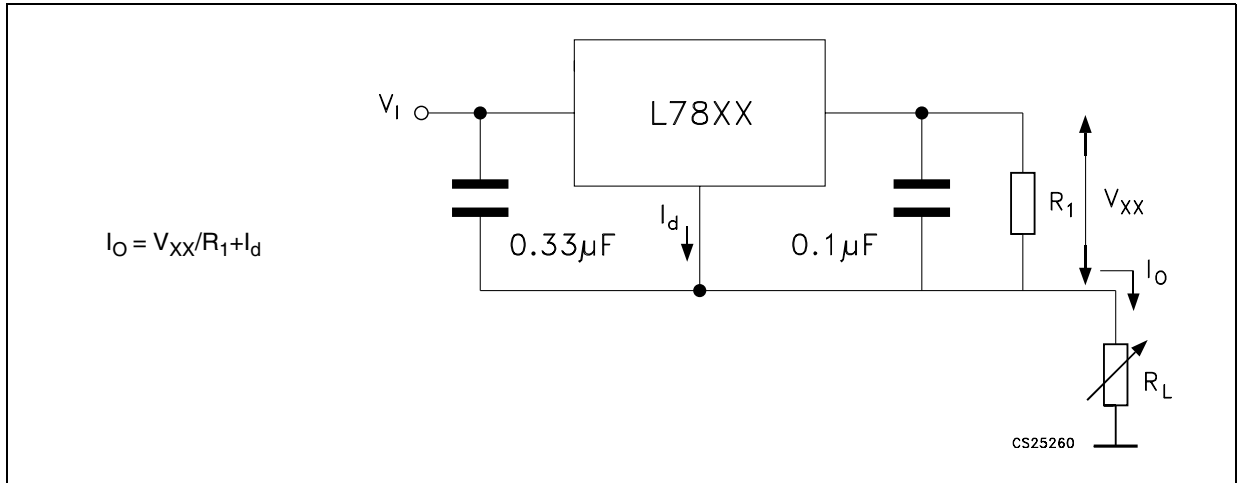

Figure 18. Circuit for increasing output voltage

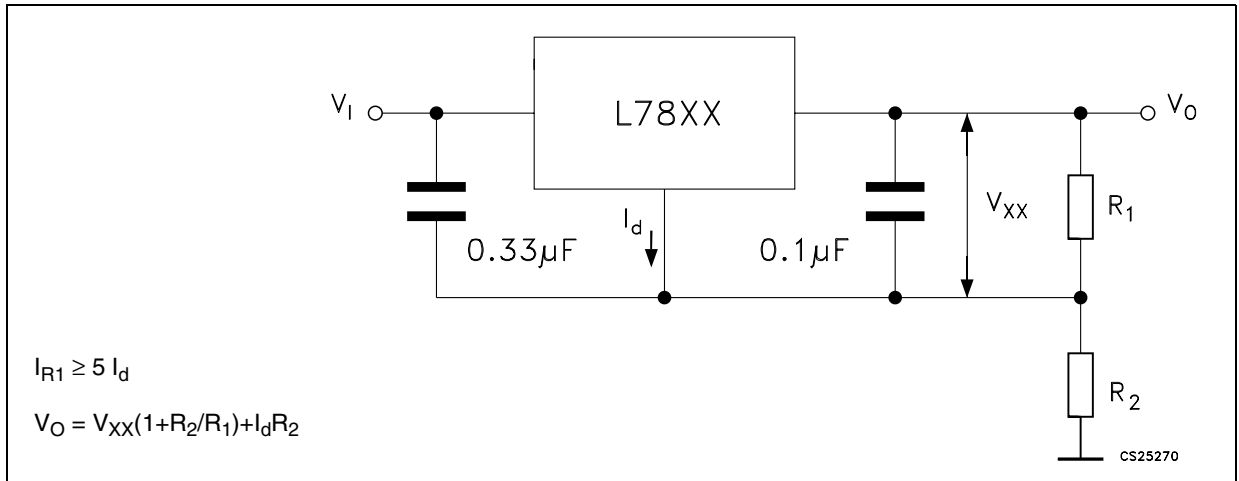

Figure 19. Adjustable output regulator (7 to 30V)

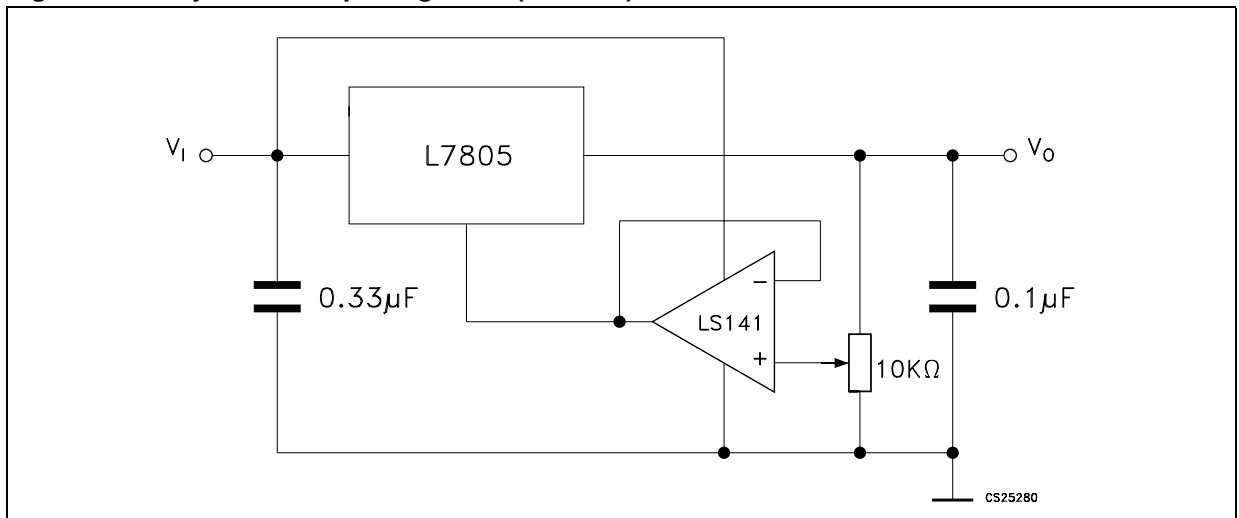

Figure 20. 0.5 to 10V Regulator

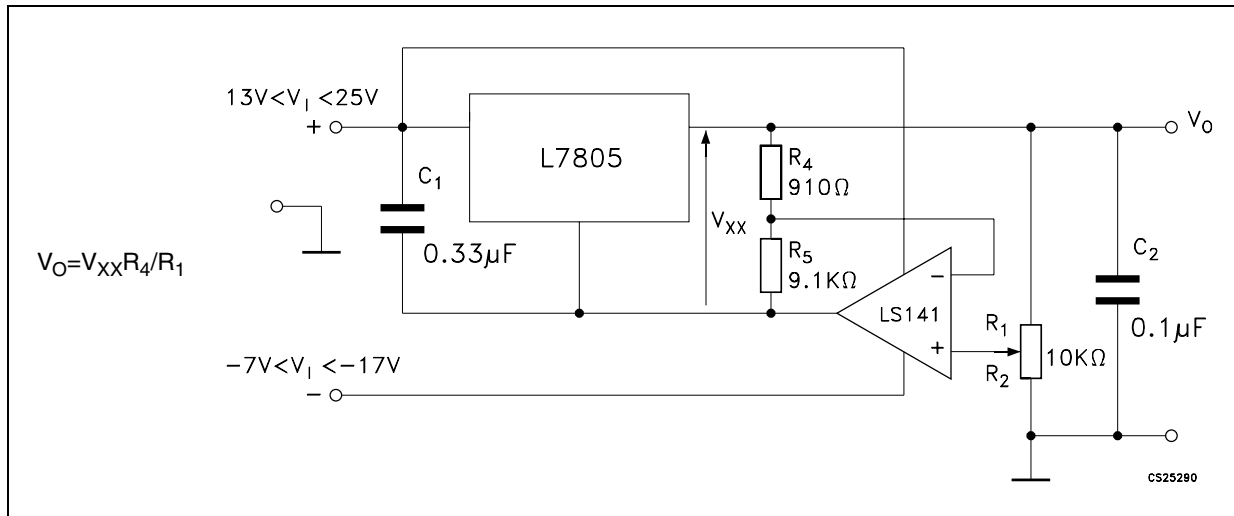

Figure 21. High current voltage regulator

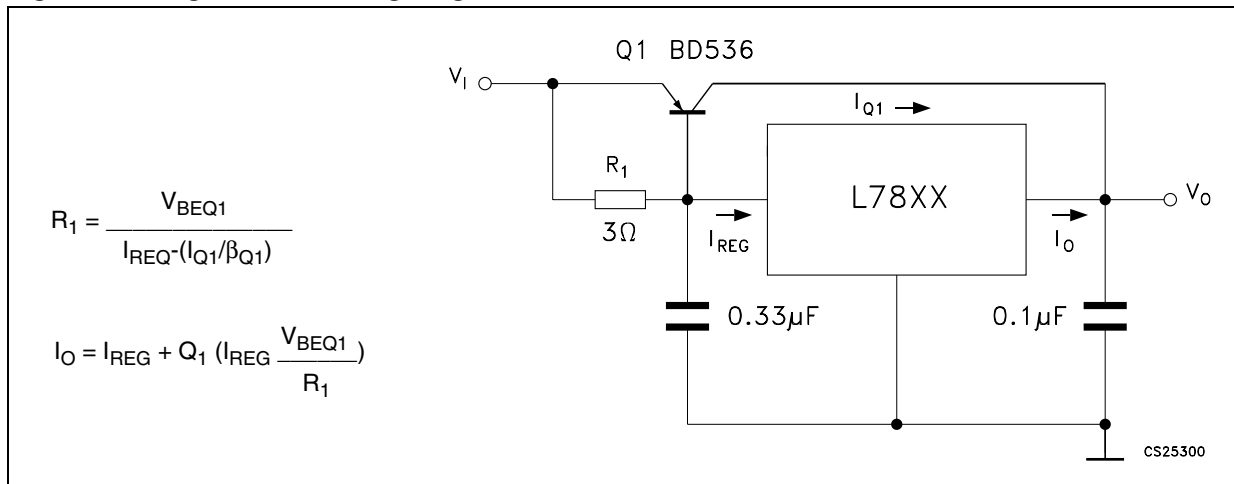

Figure 22. High output current with short circuit protection

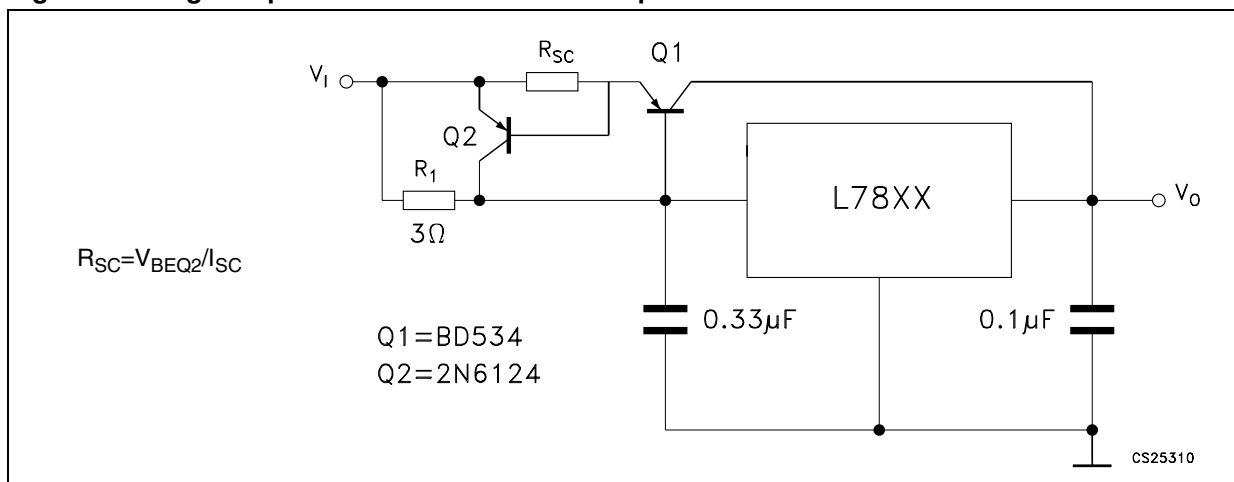

Figure 23. Tracking voltage regulator

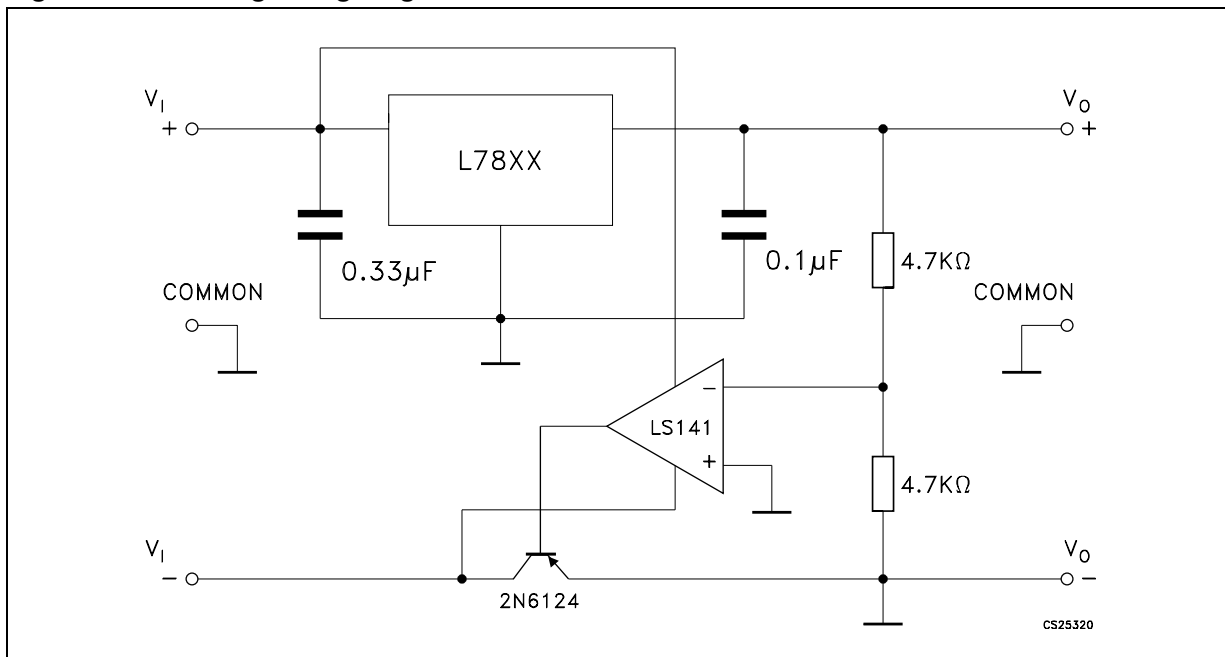
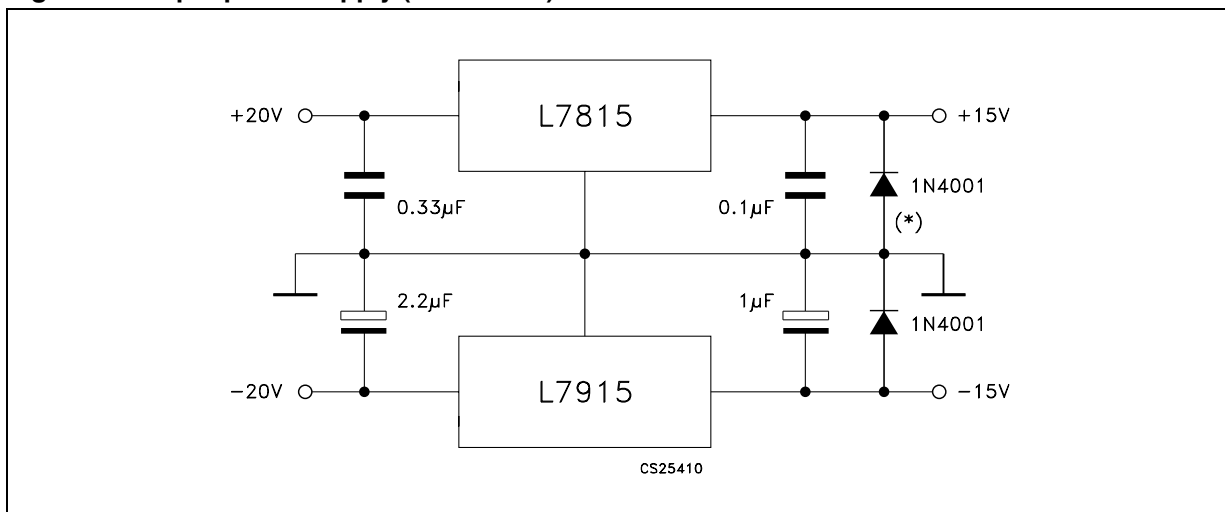

Figure 24. Split power supply ($\pm 15\text{V} - 1\text{A}$)



* Against potential latch-up problems.

Figure 25. Negative output voltage circuit

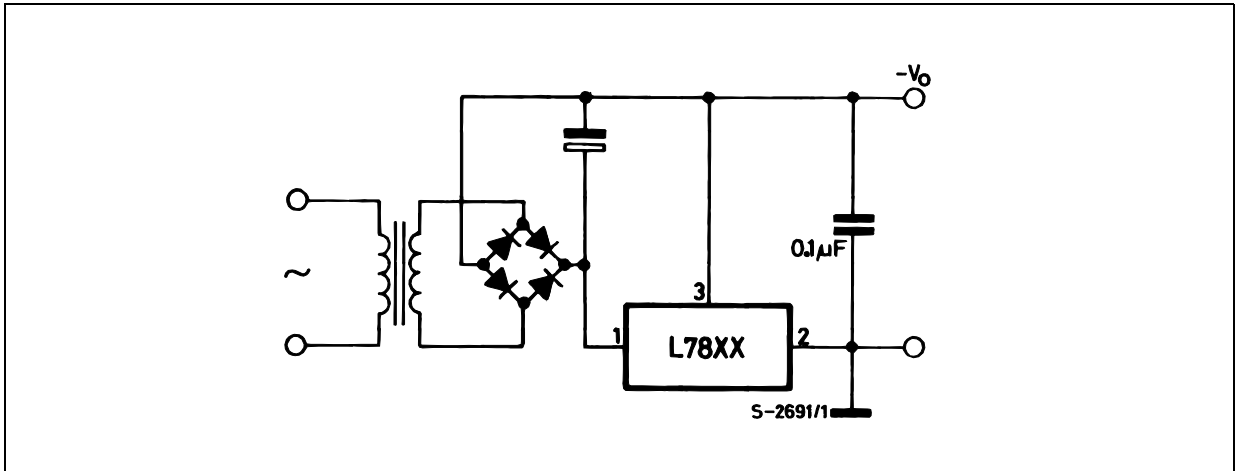

Figure 26. Switching regulator

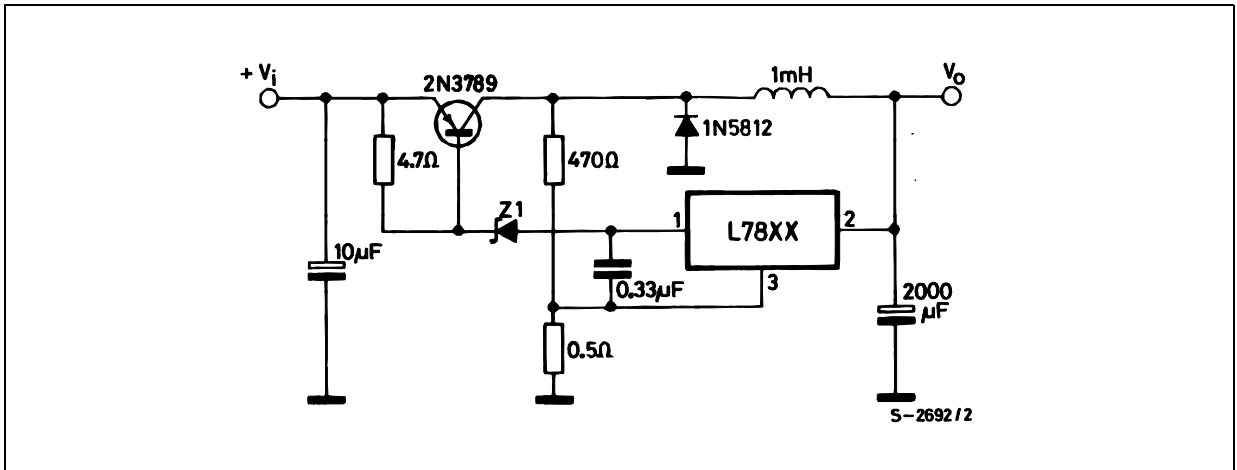

Figure 27. High input voltage circuit

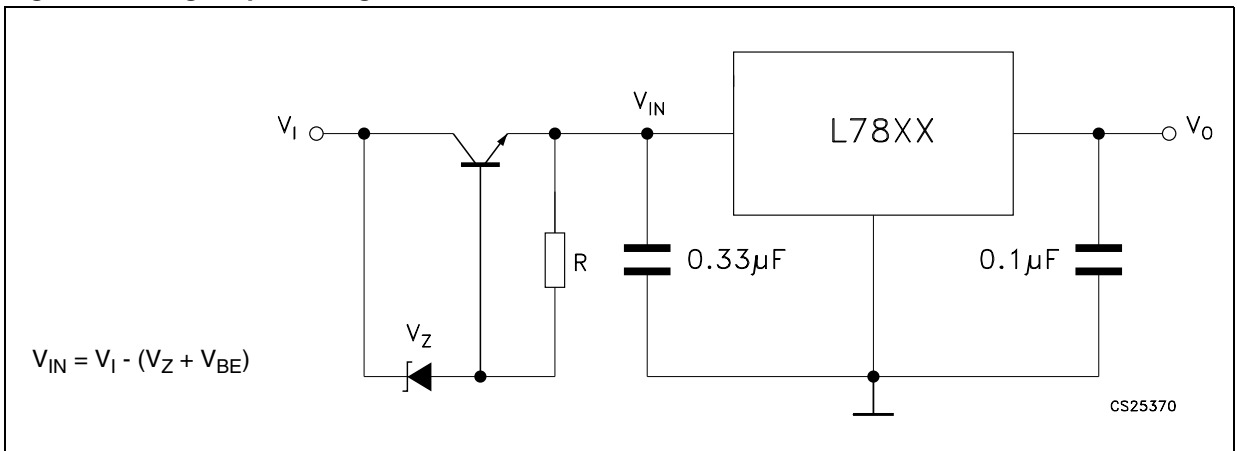

Figure 28. High input voltage circuit

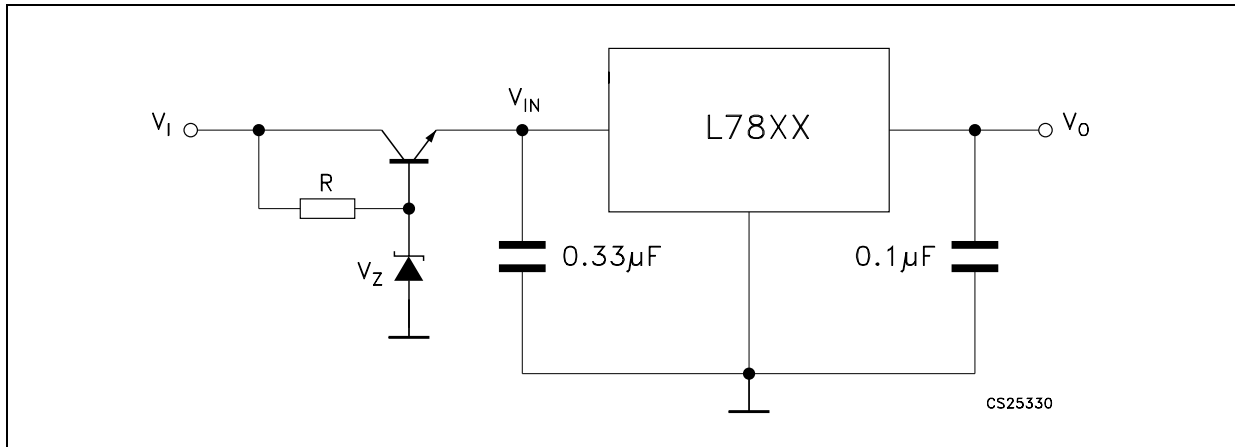

Figure 29. High output voltage regulator

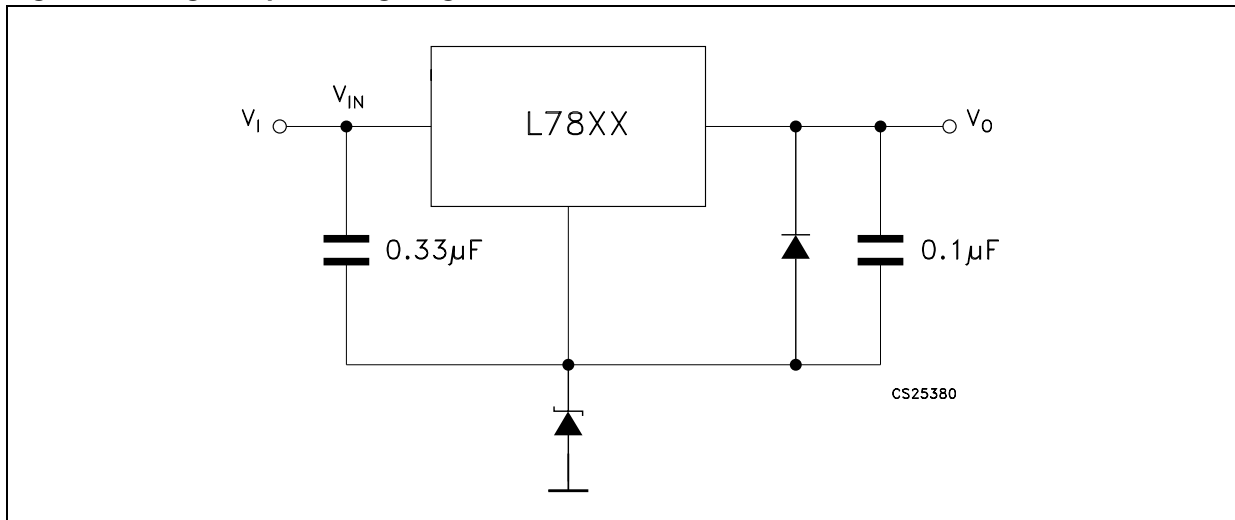

Figure 30. High input and output voltage

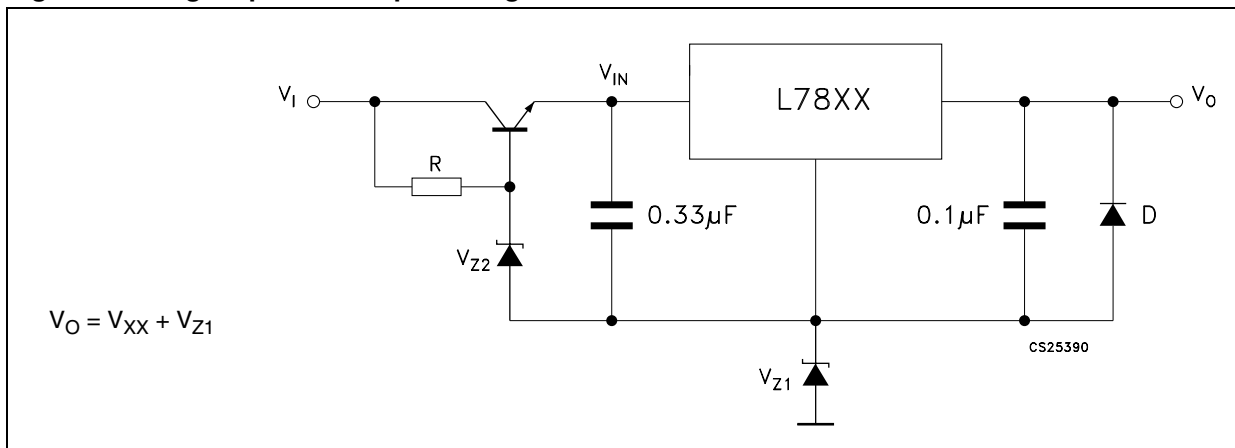

Figure 31. Reducing power dissipation with dropping resistor

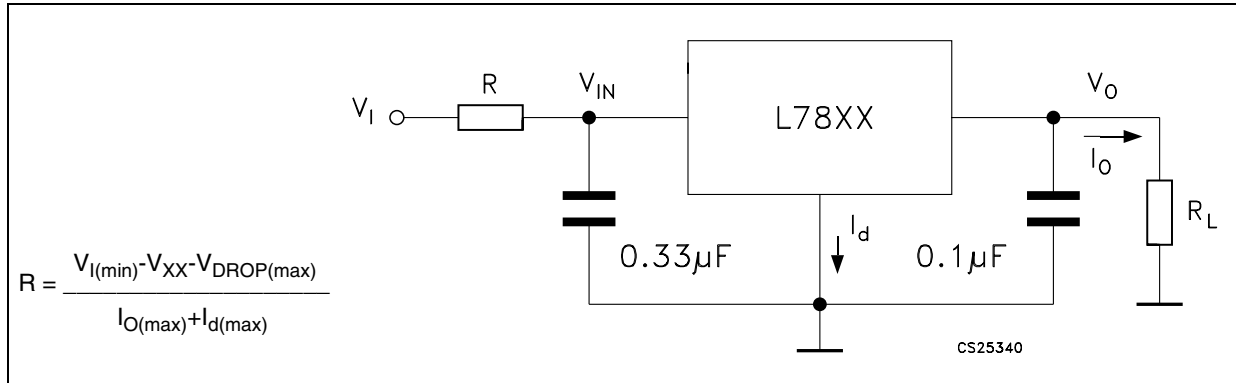

Figure 32. Remote shutdown

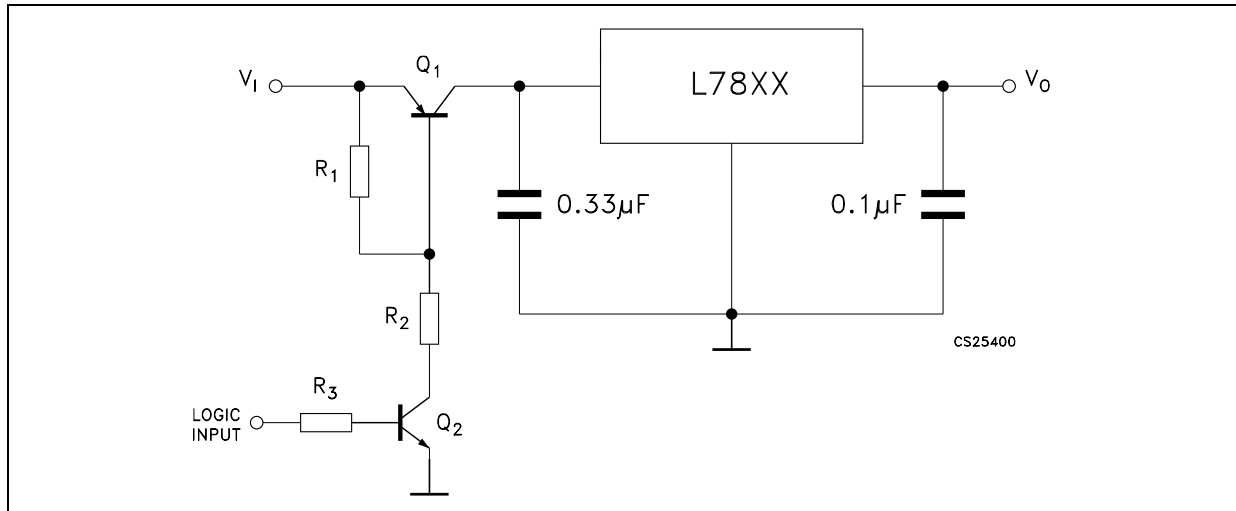
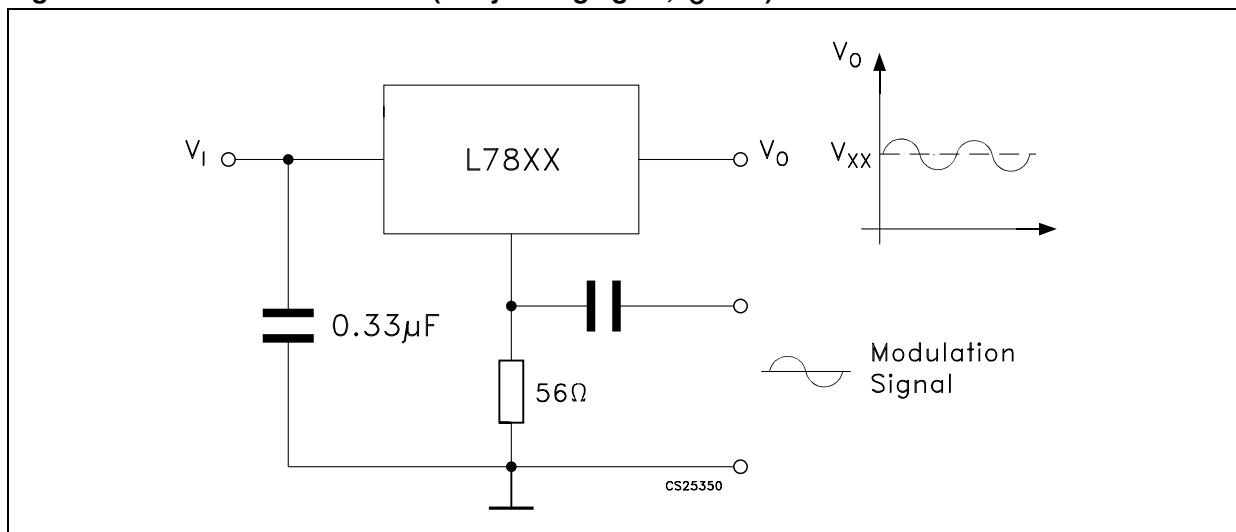
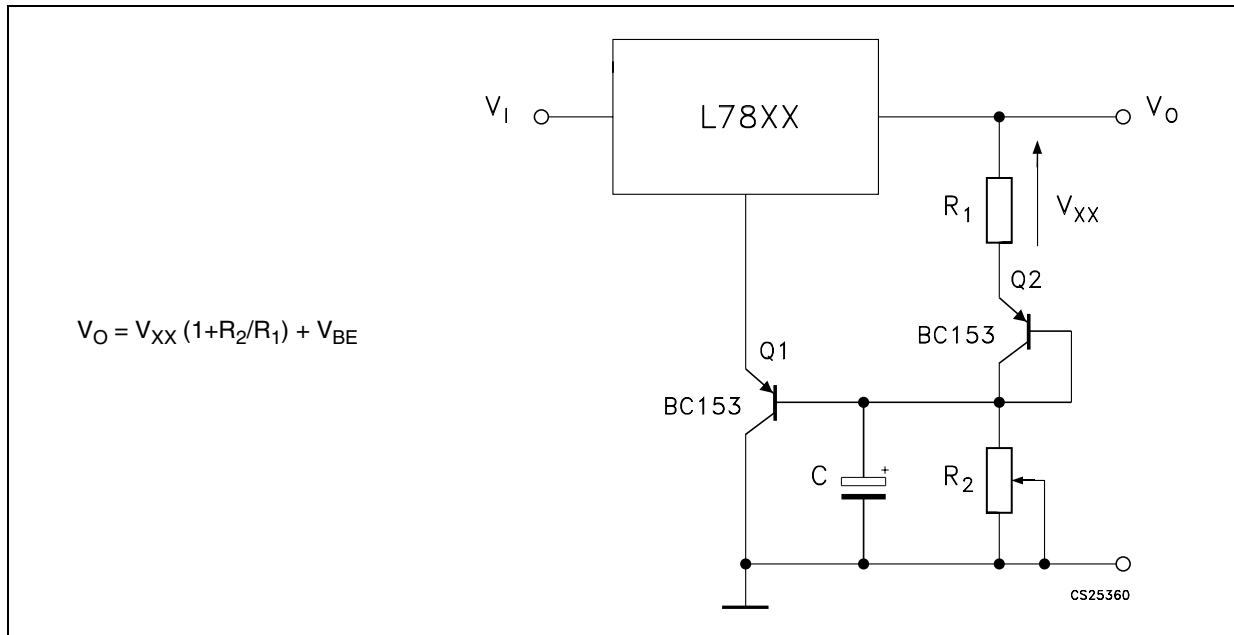

Figure 33. Power AM modulator (unity voltage gain, $I_O \leq 0.5$)



Note: The circuit performs well up to 100 KHz.

Figure 34. Adjustable output voltage with temperature compensation



Note: Q_2 is connected as a diode in order to compensate the variation of the $Q_1 V_{BE}$ with the temperature. C allows a slow rise time of the V_O .

Figure 35. Light controllers ($V_{Omin} = V_{XX} + V_{BE}$)

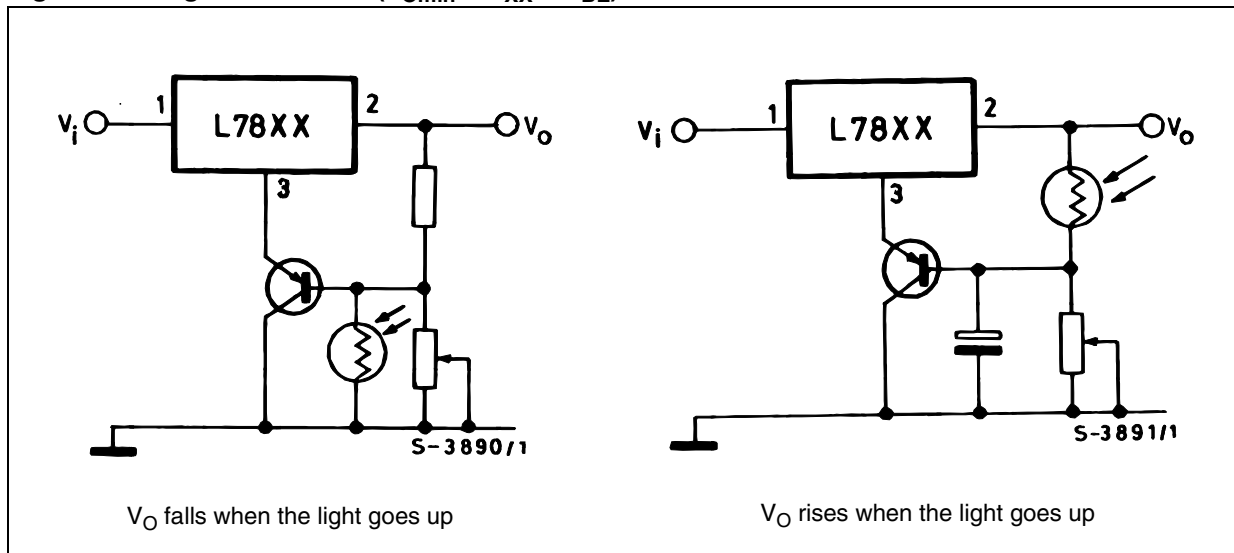
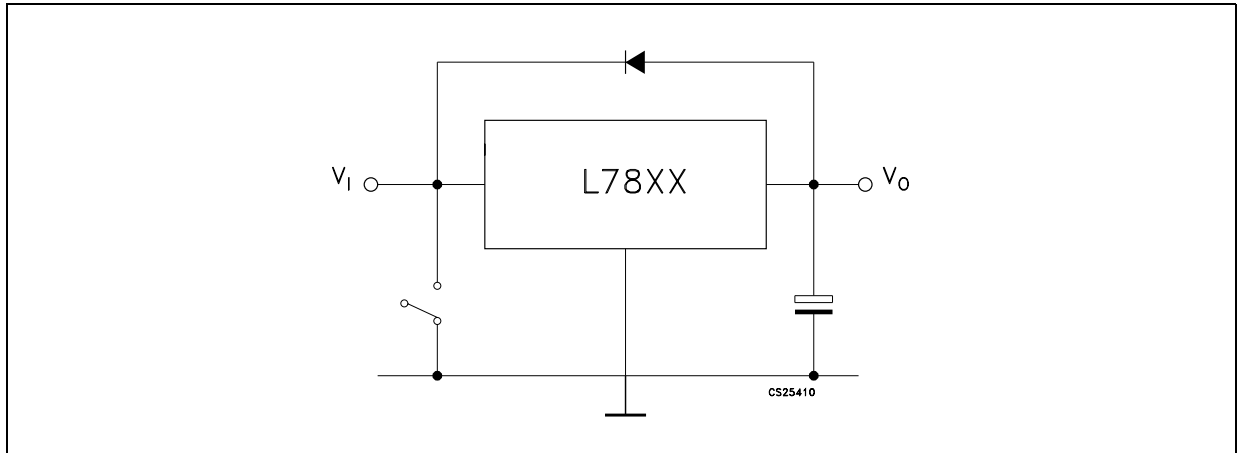

Figure 36. Protection against input short-circuit with high capacitance loads

1. Application with high capacitance loads and an output voltage greater than 6 volts need an external diode (see fig. 32) to protect the device against input short circuit. In this case the input voltage falls rapidly while the output voltage decrease slowly. The capacitance discharges by means of the Base-Emitter junction of the series pass transistor in the regulator. If the energy is sufficiently high, the transistor may be destroyed. The external diode by-passes the current from the IC to ground.

6 Package mechanical data

In order to meet environmental requirements, ST offers these devices in ECOPACK® packages. These packages have a Lead-free second level interconnect. The category of second Level Interconnect is marked on the package and on the inner box label, in compliance with JEDEC Standard JESD97. The maximum ratings related to soldering conditions are also marked on the inner box label. ECOPACK is an ST trademark. ECOPACK specifications are available at: www.st.com.

TO-3 MECHANICAL DATA

DIM.	mm.			inch		
	MIN.	TYP	MAX.	MIN.	TYP.	MAX.
A		11.85			0.466	
B	0.96	1.05	1.10	0.037	0.041	0.043
C			1.70			0.066
D			8.7			0.342
E			20.0			0.787
G		10.9			0.429	
N		16.9			0.665	
P			26.2			1.031
R	3.88		4.09	0.152		0.161
U			39.5			1.555
V		30.10			1.185	

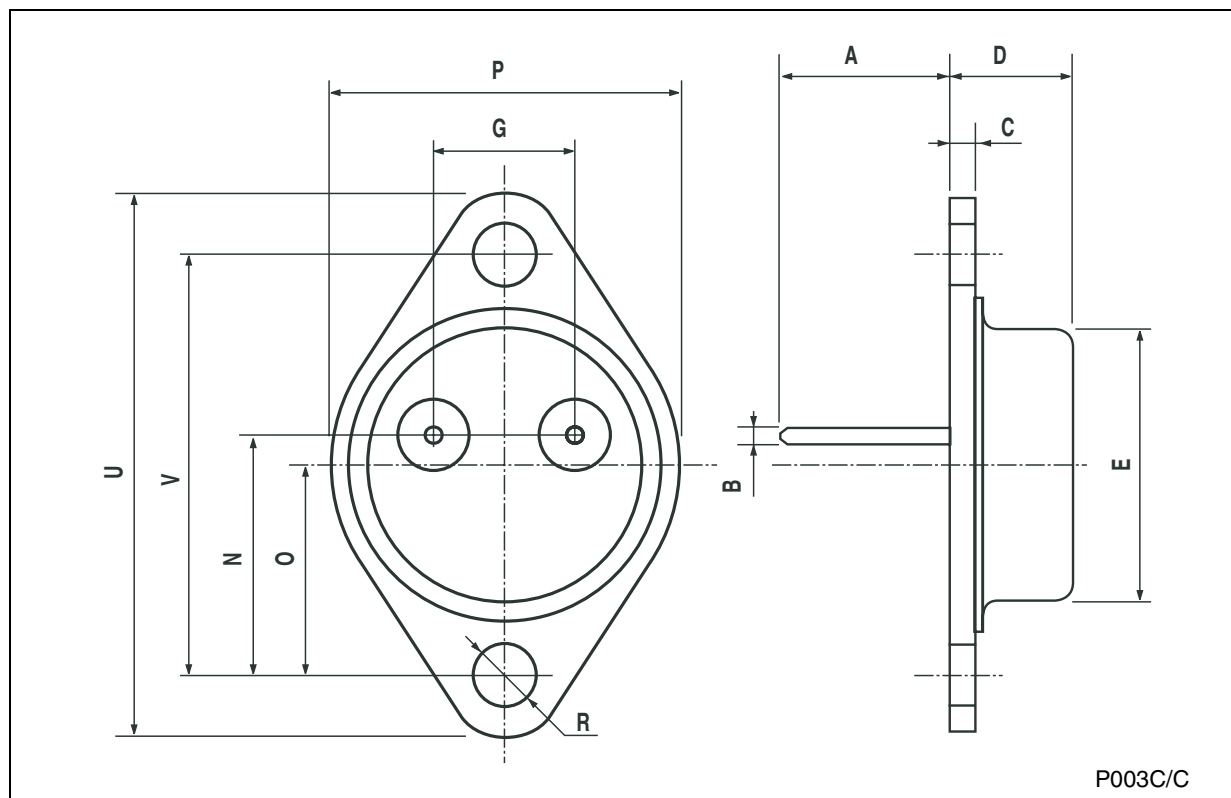

TO-220 (A TYPE) MECHANICAL DATA

DIM.	mm.			inch		
	MIN.	TYP	MAX.	MIN.	TYP.	MAX.
A	4.40		4.60	0.173		0.181
b	0.61		0.88	0.024		0.034
b1	1.15		1.70	0.045		0.067
c	0.49		0.70	0.019		0.027
D	15.25		15.75	0.600		0.620
E	10.0		10.40	0.393		0.409
e	2.4		2.7	0.094		0.106
e1	4.95		5.15	0.194		0.203
F	1.23		1.32	0.048		0.051
H1	6.2		6.6	0.244		0.260
J1	2.40		2.72	0.094		0.107
L	13.0		14.0	0.511		0.551
L1	3.5		3.93	0.137		0.154
L20		16.4			0.645	
L30		28.9			1.138	
φP	3.75		3.85	0.147		0.151
Q	2.65		2.95	0.104		0.116

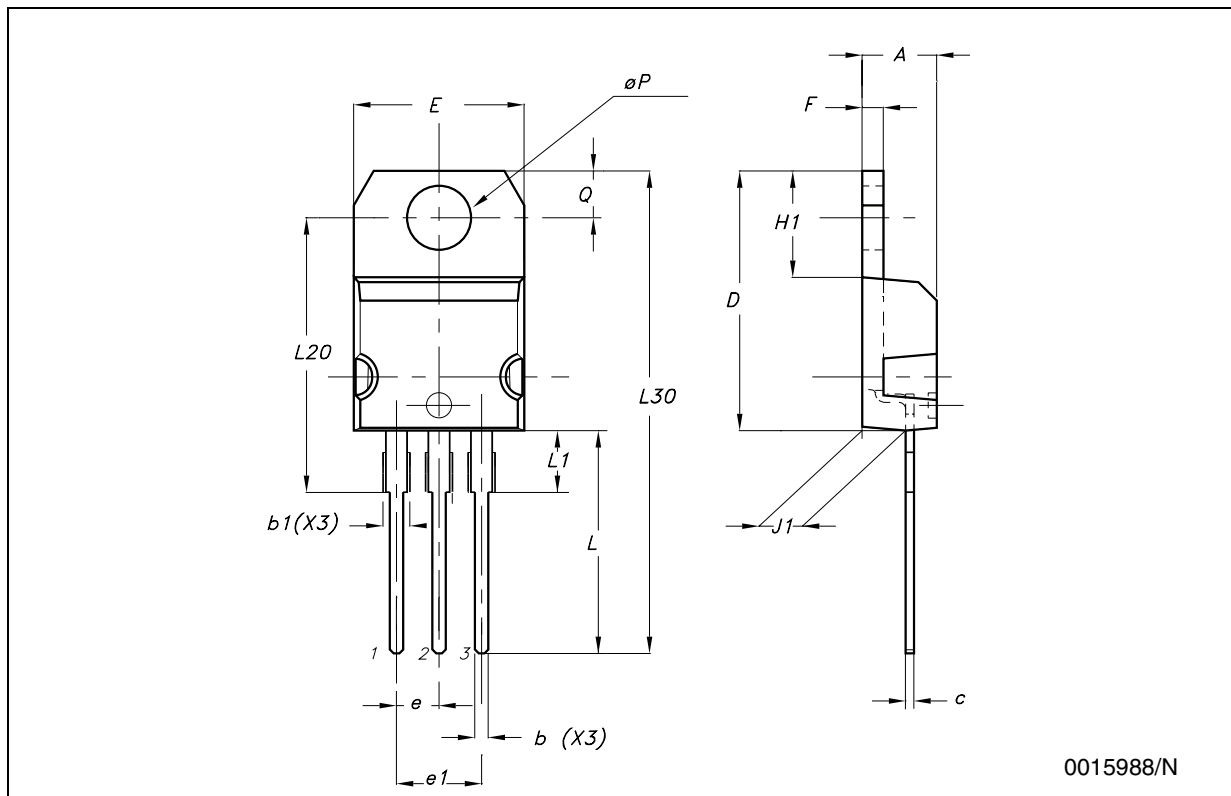

0015988/N

TO-220 (C TYPE) MECHANICAL DATA

DIM.	mm.			inch		
	MIN.	TYP	MAX.	MIN.	TYP.	MAX.
A	4.30		4.70	0.169		0.185
b	0.70		0.90	0.028		0.035
b1	1.42		1.62	0.056		0.064
c	0.45		0.60	0.018		0.024
D		15.70			0.618	
E	9.80		10.20	0.386		0.402
e		2.54			0.100	
e1		5.08			0.200	
F	1.25		1.39	0.049		0.055
H1		6.5			0.256	
J1	2.20		2.60	0.087		0.202
L	12.88		13.28	0.507		0.523
L1		3			0.118	
L20	15.70		16.1	0.618		0.634
L30		28.9			1.138	
φP	3.50		3.70	0.138		0.146
Q	2.70		2.90	0.106		0.114

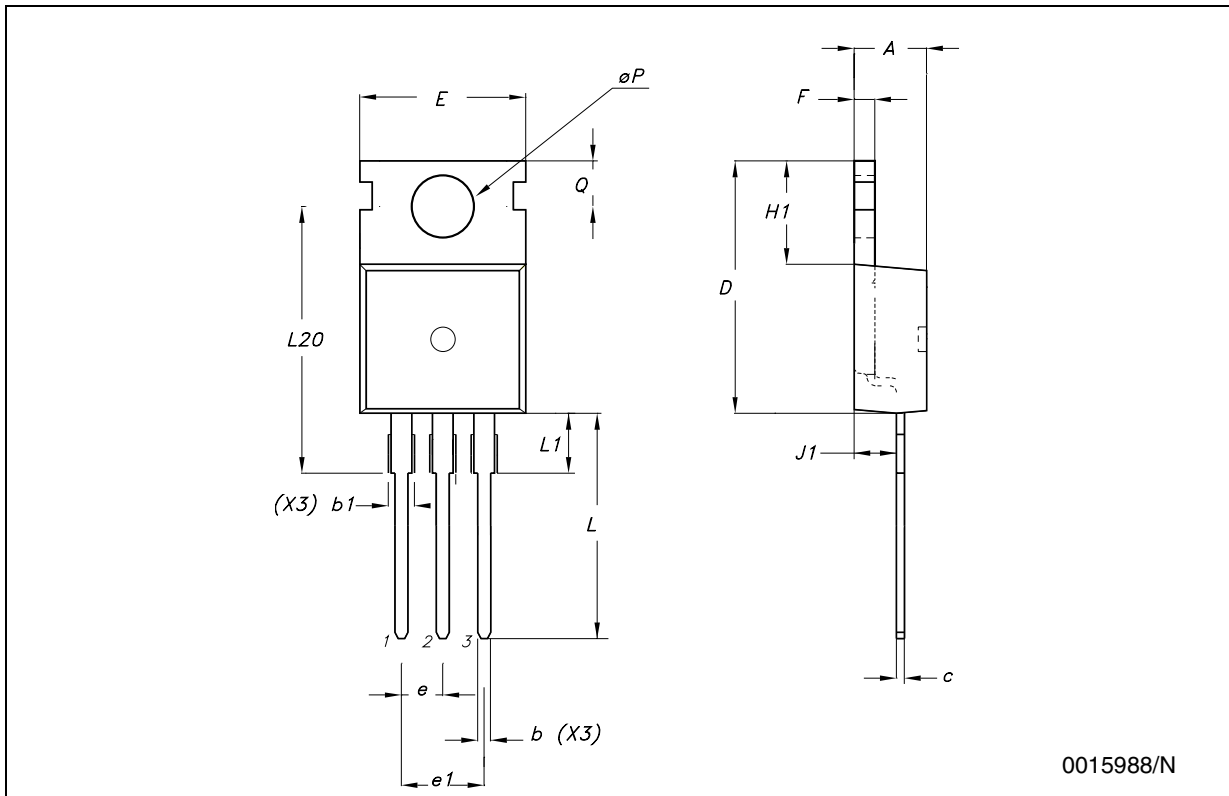

0015988/N

TO-220 (E TYPE) MECHANICAL DATA

DIM.	mm.			inch		
	MIN.	TYP	MAX.	MIN.	TYP.	MAX.
A	4.47		4.67	0.176		0.184
b	0.70		0.91	0.028		0.036
b1	1.17		1.37	0.046		0.054
c	0.31		0.53	0.012		0.021
D	14.60		15.70	0.575		0.618
E	9.96		10.36	0.392		0.408
e		2.54			0.100	
e1		5.08			0.200	
F	1.17		1.37	0.046		0.054
H1	6.1		6.8	0.240		0.268
J1	2.52		2.82	0.099		0.111
L	12.70		13.80	0.500		0.543
L1	3.20		3.96	0.126		0.156
L20	15.21		16.77	0.599		0.660
φP	3.73		3.94	0.147		0.155
Q	2.59		2.89	0.102		0.114

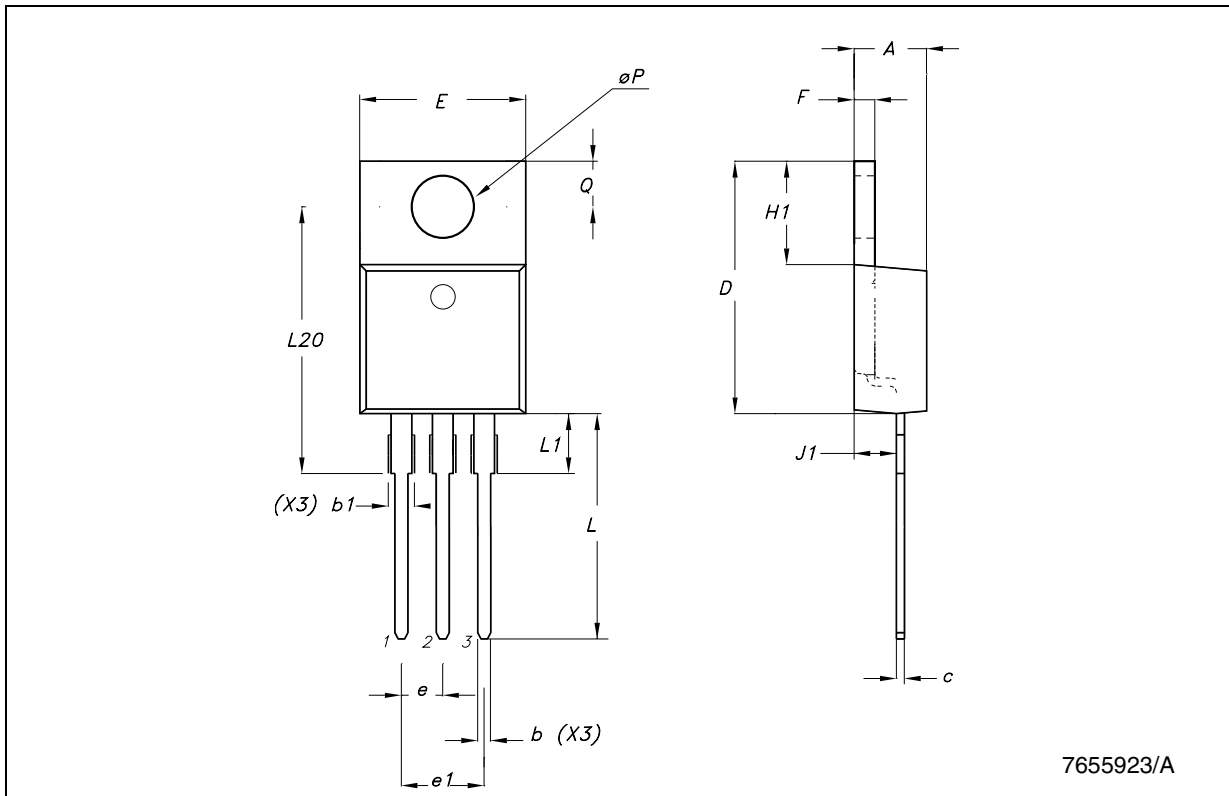

TO-220FP MECHANICAL DATA

DIM.	mm.			inch		
	MIN.	TYP	MAX.	MIN.	TYP.	MAX.
A	4.40		4.60	0.173		0.181
B	2.5		2.7	0.098		0.106
D	2.5		2.75	0.098		0.108
E	0.45		0.70	0.017		0.027
F	0.75		1	0.030		0.039
F1	1.15		1.50	0.045		0.059
F2	1.15		1.50	0.045		0.059
G	4.95		5.2	0.194		0.204
G1	2.4		2.7	0.094		0.106
H	10.0		10.40	0.393		0.409
L2		16			0.630	
L3	28.6		30.6	1.126		1.204
L4	9.8		10.6	0.385		0.417
L5	2.9		3.6	0.114		0.142
L6	15.9		16.4	0.626		0.645
L7	9		9.3	0.354		0.366
DIA.	3		3.2	0.118		0.126

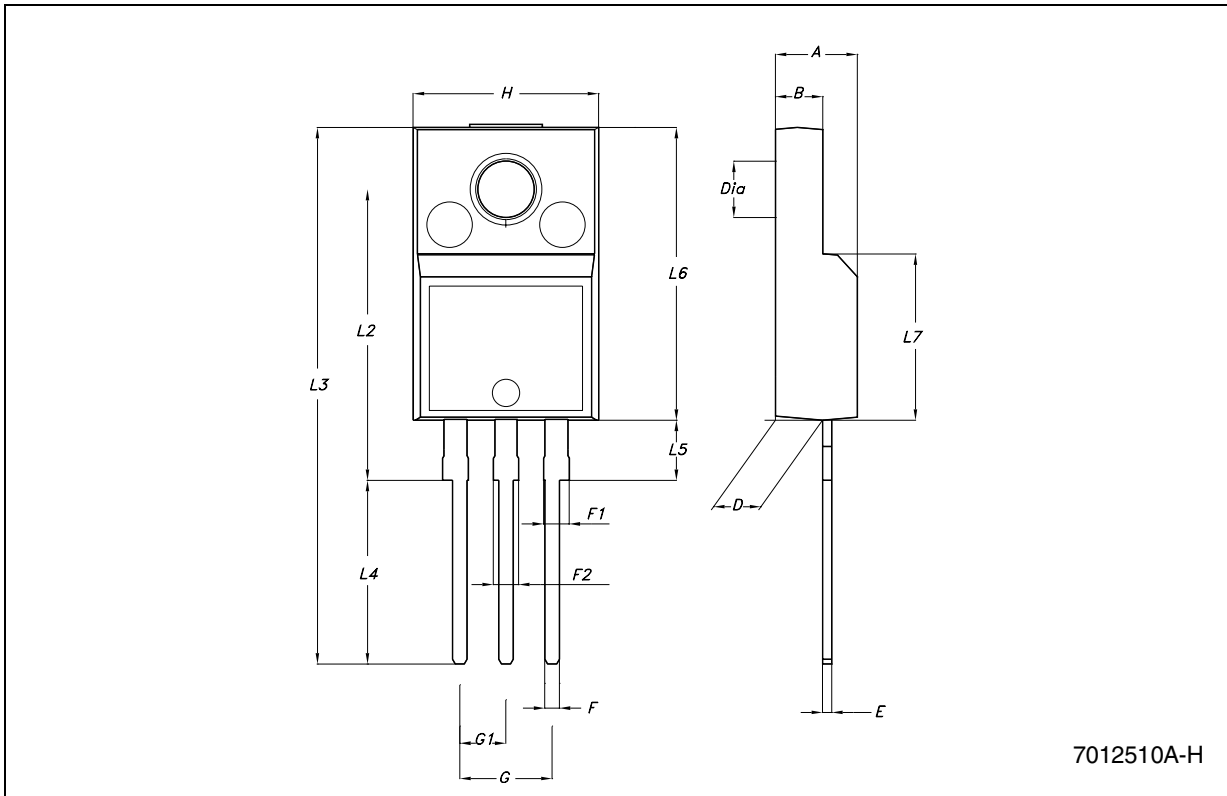

7012510A-H

D²PAK (A TYPE) MECHANICAL DATA

DIM.	mm.			inch		
	MIN.	TYP	MAX.	MIN.	TYP.	MAX.
A	4.4		4.6	0.173		0.181
A1	0.03		0.23	0.001		0.009
b	0.7		0.93	0.027		0.036
b2	1.14		1.7	0.044		0.067
c	0.45		0.6	0.017		0.023
c2	1.23		1.36	0.048		0.053
D	8.95		9.35	0.352		0.368
D1	8			0.315		
E	10		10.4	0.393		0.409
E1	8.5			0.335		
e		2.54			0.100	
e1	4.88		5.28	0.192		0.208
H	15		15.85	0.590		0.624
J1	2.49		2.69	0.098		0.106
L	2.29		2.79	0.090		0.110
L1	1.27		1.4	0.050		0.055
L2	1.3		1.75	0.051		0.069
R		0.4			0.016	
V2	0°		8°	0°		8°

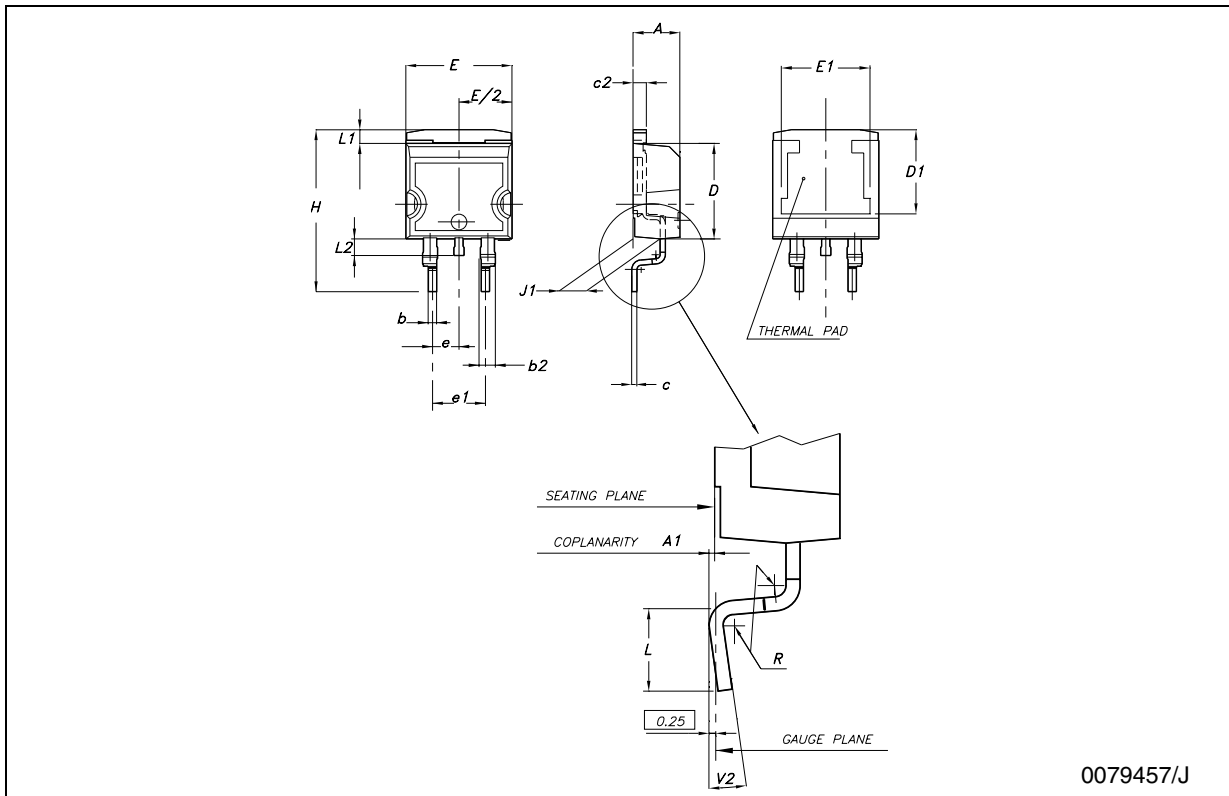

0079457/J

D²PAK (C TYPE) MECHANICAL DATA

DIM.	mm.			inch		
	MIN.	TYP	MAX.	MIN.	TYP.	MAX.
A	4.3		4.7	0.169		0.185
A1	0		0.20	0.000		0.008
b	0.70		0.90	0.028		0.035
b2	1.17		1.37	0.046		0.054
c	0.45	0.50	0.6	0.018	0.020	0.024
c2	1.25	1.30	1.40	0.049	0.051	0.055
D	9.0	9.2	9.4	0.354	0.362	0.370
D1	7.5			0.295		
E	9.8		10.2	0.386		0.402
E1	7.5			0.295		
e		2.54			0.100	
e1		5.08			0.200	
H	15	15.30	15.60	0.591	0.602	0.614
J1	2.20		2.60	0.087		0.102
L	1.79		2.79	0.070		0.110
L1	1.0		1.4	0.039		0.055
L2	1.2		1.6	0.047		0.063
R		0.3			0.012	
V2	0°		3°	0°		3°

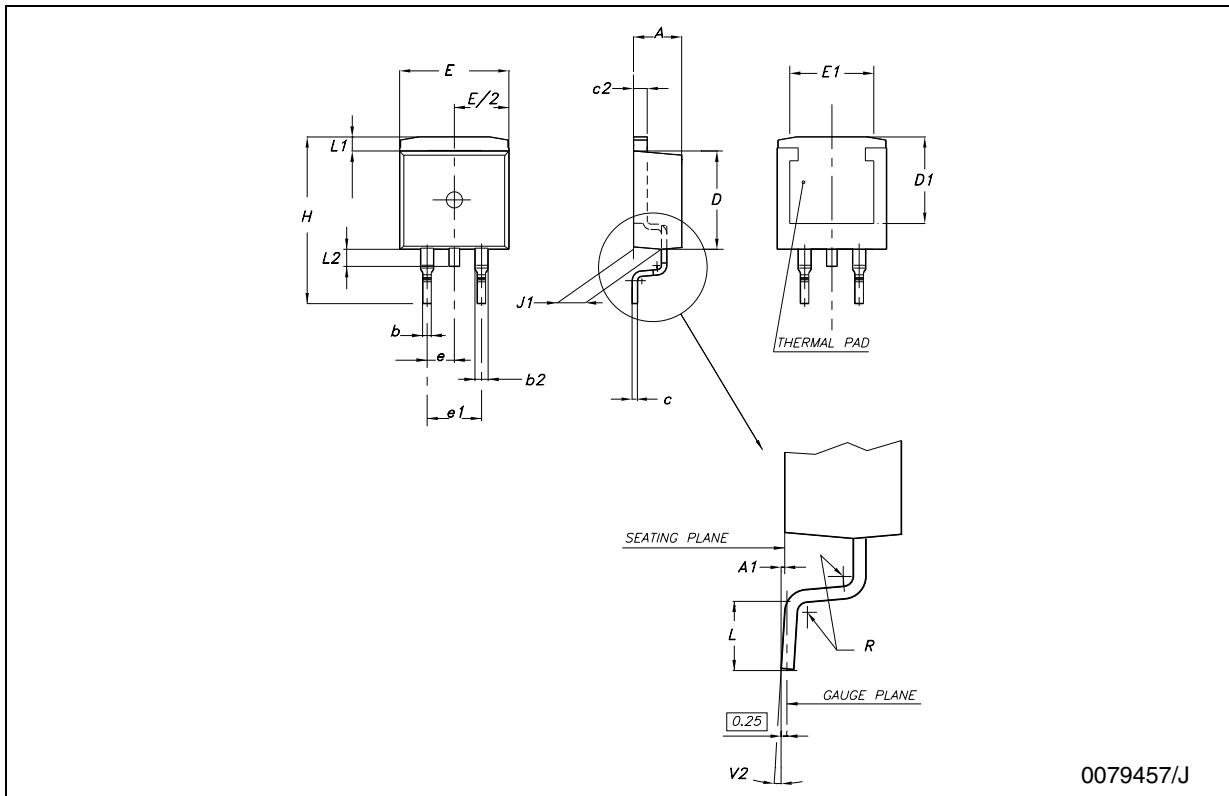

Tape & Reel D²PAK-P²PAK-D²PAK/A-P²PAK/A MECHANICAL DATA

DIM.	mm.			inch		
	MIN.	TYP	MAX.	MIN.	TYP.	MAX.
A			180			7.086
C	12.8	13.0	13.2	0.504	0.512	0.519
D	20.2			0.795		
N	60			2.362		
T			14.4			0.567
Ao	10.50	10.6	10.70	0.413	0.417	0.421
Bo	15.70	15.80	15.90	0.618	0.622	0.626
Ko	4.80	4.90	5.00	0.189	0.193	0.197
Po	3.9	4.0	4.1	0.153	0.157	0.161
P	11.9	12.0	12.1	0.468	0.472	0.476

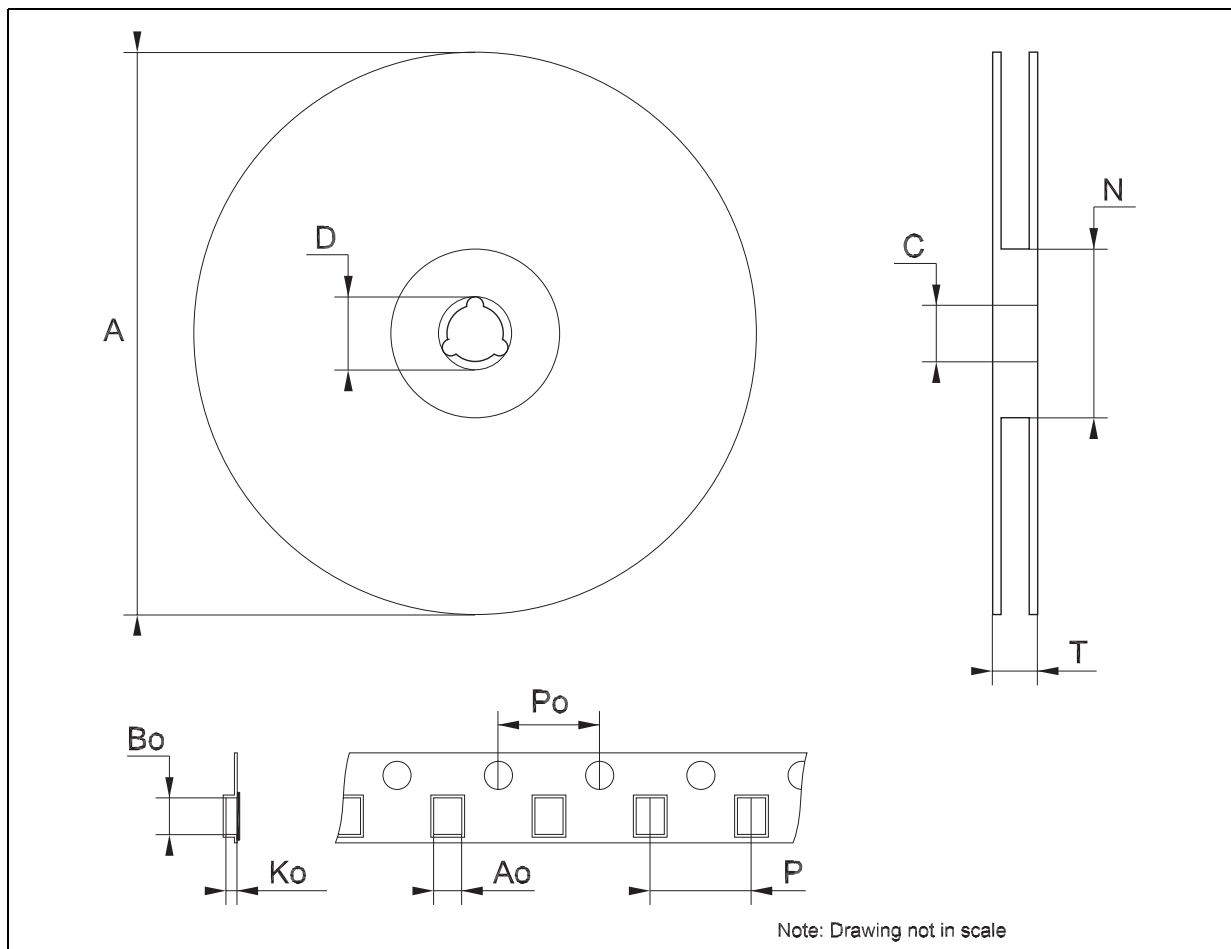

7 Order code

Table 23. Order code

Part numbers	Packaging					
	TO-220 (A Type)	TO-220 (C Type)	D ² PAK (A Type)	D ² PAK (C Type)	TO-220FP	TO-3
L7805						L7805T
L7805C	L7805CV	L7805C-V	L7805CD2T-TR	L7805C-D2TR	L7805CP	L7805CT
L7852C	L7852CV		L7852CD2T-TR ⁽¹⁾		L7852CP ⁽¹⁾	L7852CT ⁽¹⁾
L7806C	L7806CV	L7806C-V	L7806CD2T-TR		L7806CP	L7806CT
L7808C	L7808CV	L7808C-V	L7808CD2T-TR		L7808CP	L7808CT
L7885C	L7885CV		L7885CD2T-TR ⁽¹⁾		L7885CP ⁽¹⁾	L7885CT ⁽¹⁾
L7809C	L7809CV	L7809C-V	L7809CD2T-TR		L7809CP	L7809CT
L7810C	L7810CV		L7810CD2T-TR ⁽¹⁾		L7810CP	
L7812C	L7812CV	L7812C-V	L7812CD2T-TR		L7812CP	L7812CT
L7815C	L7815CV	L7815C-V	L7815CD2T-TR		L7815CP	L7815CT
L7818C	L7818CV		L7818CD2T-TR ⁽¹⁾		L7818CP	L7818CT
L7820C	L7820CV		L7820CD2T-TR ⁽¹⁾		L7820CP ⁽¹⁾	L7820CT ⁽¹⁾
L7824C	L7824CV		L7824CD2T-TR		L7824CP	L7824CT

1. Available on request.

8 Revision history

Table 24. Revision history

Date	Revision	Changes
21-Jun-2004	12	Document updating.
03-Aug-2006	13	Order Codes has been updated and new template.

Please Read Carefully:

Information in this document is provided solely in connection with ST products. STMicroelectronics NV and its subsidiaries ("ST") reserve the right to make changes, corrections, modifications or improvements, to this document, and the products and services described herein at any time, without notice.

All ST products are sold pursuant to ST's terms and conditions of sale.

Purchasers are solely responsible for the choice, selection and use of the ST products and services described herein, and ST assumes no liability whatsoever relating to the choice, selection or use of the ST products and services described herein.

No license, express or implied, by estoppel or otherwise, to any intellectual property rights is granted under this document. If any part of this document refers to any third party products or services it shall not be deemed a license grant by ST for the use of such third party products or services, or any intellectual property contained therein or considered as a warranty covering the use in any manner whatsoever of such third party products or services or any intellectual property contained therein.

UNLESS OTHERWISE SET FORTH IN ST'S TERMS AND CONDITIONS OF SALE ST DISCLAIMS ANY EXPRESS OR IMPLIED WARRANTY WITH RESPECT TO THE USE AND/OR SALE OF ST PRODUCTS INCLUDING WITHOUT LIMITATION IMPLIED WARRANTIES OF MERCHANTABILITY, FITNESS FOR A PARTICULAR PURPOSE (AND THEIR EQUIVALENTS UNDER THE LAWS OF ANY JURISDICTION), OR INFRINGEMENT OF ANY PATENT, COPYRIGHT OR OTHER INTELLECTUAL PROPERTY RIGHT.

UNLESS EXPRESSLY APPROVED IN WRITING BY AN AUTHORIZED ST REPRESENTATIVE, ST PRODUCTS ARE NOT RECOMMENDED, AUTHORIZED OR WARRANTED FOR USE IN MILITARY, AIR CRAFT, SPACE, LIFE SAVING, OR LIFE SUSTAINING APPLICATIONS, NOR IN PRODUCTS OR SYSTEMS WHERE FAILURE OR MALFUNCTION MAY RESULT IN PERSONAL INJURY, DEATH, OR SEVERE PROPERTY OR ENVIRONMENTAL DAMAGE. ST PRODUCTS WHICH ARE NOT SPECIFIED AS "AUTOMOTIVE GRADE" MAY ONLY BE USED IN AUTOMOTIVE APPLICATIONS AT USER'S OWN RISK.

Resale of ST products with provisions different from the statements and/or technical features set forth in this document shall immediately void any warranty granted by ST for the ST product or service described herein and shall not create or extend in any manner whatsoever, any liability of ST.

ST and the ST logo are trademarks or registered trademarks of ST in various countries.

Information in this document supersedes and replaces all information previously supplied.

The ST logo is a registered trademark of STMicroelectronics. All other names are the property of their respective owners.

© 2006 STMicroelectronics - All rights reserved

STMicroelectronics group of companies

Australia - Belgium - Brazil - Canada - China - Czech Republic - Finland - France - Germany - Hong Kong - India - Israel - Italy - Japan - Malaysia - Malta - Morocco - Singapore - Spain - Sweden - Switzerland - United Kingdom - United States of America

www.st.com