

## dSPIN fully integrated microstepping motor driver with motion engine and SPI

Datasheet – production data

### Features

- Operating voltage: 8 - 45 V
- 7.0 A out peak current (3.0 A r.m.s.)
- Low  $R_{DS(on)}$  Power MOSFETs
- Programmable speed profile and positioning
- Programmable power MOS slew rate
- Up to 1/128 microstepping
- Sensorless stall detection
- SPI interface
- Low quiescent and standby currents
- Programmable non-dissipative overcurrent protection on high and low-side
- Two levels of overtemperature protection

### Application

- Bipolar stepper motors

### Description

The L6470, realized in analog mixed signal technology, is an advanced fully integrated solution suitable for driving two-phase bipolar stepper motors with microstepping. It integrates a dual low  $R_{DS(on)}$  DMOS full bridge with all of the

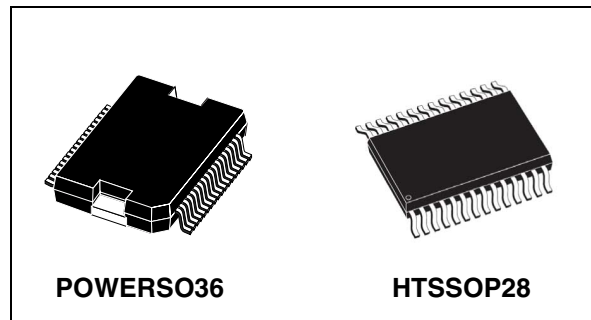

power switches equipped with an accurate on-chip current sensing circuitry suitable for non-dissipative current control and overcurrent protection. Thanks to a unique control system, a true 1/128 steps resolution is achieved. The digital control core can generate user defined motion profiles with acceleration, deceleration, speed or target position, easily programmed through a dedicated registers set. All commands and data registers, including those used to set analogue values (i.e. current control value, current protection trip point, deadtime, PWM frequency, etc.) are sent through a standard 5-Mbit/s SPI. A very rich set of protections (thermal, low bus voltage, overcurrent, motor stall) allows the design of a fully protected application, as required by the most demanding motor control applications.

**Table 1. Device summary**

Order codes	Package	Packaging
L6470H	HTSSOP28	Tube
L6470HTR	HTSSOP28	Tape and reel
L6470PD	POWERSO36	Tube
L6470PDTR	POWERSO36	Tape and reel

# Contents

- 1      Block diagram ..... 8**
- 2      Electrical data ..... 9**
  - 2.1 Absolute maximum ratings ..... 9
  - 2.2 Recommended operating conditions ..... 10
  - 2.3 Thermal data ..... 10
- 3      Electrical characteristics ..... 11**
- 4      Pin connection ..... 16**
  - 4.1 Pin list ..... 17
- 5      Typical applications ..... 19**
- 6      Functional description ..... 21**
  - 6.1 Device power-up ..... 21
  - 6.2 Logic I/O ..... 21
  - 6.3 Charge pump ..... 21
  - 6.4 Microstepping ..... 22
    - 6.4.1 Automatic full-step mode ..... 23
  - 6.5 Absolute position counter ..... 23
  - 6.6 Programmable speed profiles ..... 23
    - 6.6.1 Infinite acceleration/deceleration mode ..... 24
  - 6.7 Motor control commands ..... 24
    - 6.7.1 Constant speed commands ..... 24
    - 6.7.2 Positioning commands ..... 25
    - 6.7.3 Motion commands ..... 25
    - 6.7.4 Stop commands ..... 26
    - 6.7.5 Step-clock mode ..... 26
    - 6.7.6 GoUntil and ReleaseSW commands ..... 26
  - 6.8 Internal oscillator and oscillator driver ..... 27
    - 6.8.1 Internal oscillator ..... 27
    - 6.8.2 External clock source ..... 27

6.9	Overcurrent detection	28
6.10	Undervoltage lockout (UVLO)	29
6.11	Thermal warning and thermal shutdown	29
6.12	Reset and standby	30
6.13	External switch (SW pin)	30
6.14	Programmable DMOS slew rate, deadtime and blanking time	31
6.15	Integrated analog-to-digital converter	31
6.16	Internal voltage regulator	31
6.17	BUSYSYNC pin	32
6.17.1	BUSY operation mode	32
6.17.2	SYNC operation mode	32
6.18	FLAG pin	33
<b>7</b>	<b>Phase current control</b>	<b>34</b>
7.1	PWM sinewave generators	34
7.2	Sensorless stall detection	35
7.3	Low speed optimization	35
7.4	BEMF compensation	36
7.5	Motor supply voltage compensation	36
7.6	Winding resistance thermal drift compensation	37
<b>8</b>	<b>Serial interface</b>	<b>38</b>
<b>9</b>	<b>Programming manual</b>	<b>40</b>
9.1	Registers and flags description	40
9.1.1	ABS_POS	41
9.1.2	EL_POS	41
9.1.3	MARK	42
9.1.4	SPEED	42
9.1.5	ACC	42
9.1.6	DEC	42
9.1.7	MAX_SPEED	43
9.1.8	MIN_SPEED	43
9.1.9	FS_SPD	43
9.1.10	KVAL_HOLD, KVAL_RUN, KVAL_ACC and KVAL_DEC	44

9.1.11	INT_SPEED	44
9.1.12	ST_SLP	45
9.1.13	FN_SLP_ACC	45
9.1.14	FN_SLP_DEC	45
9.1.15	K_THERM	45
9.1.16	ADC_OUT	46
9.1.17	OCD_TH	46
9.1.18	STALL_TH	46
9.1.19	STEP_MODE	47
9.1.20	ALARM_EN	48
9.1.21	CONFIG	49
9.1.22	STATUS	54
<b>9.2</b>	<b>Application commands</b>	<b>55</b>
9.2.1	Command management	56
9.2.2	Nop	57
9.2.3	SetParam (PARAM, VALUE)	57
9.2.4	GetParam (PARAM)	58
9.2.5	Run (DIR, SPD)	58
9.2.6	StepClock (DIR)	59
9.2.7	Move (DIR, N_STEP)	59
9.2.8	GoTo (ABS_POS)	60
9.2.9	GoTo_DIR (DIR, ABS_POS)	60
9.2.10	GoUntil (ACT, DIR, SPD)	61
9.2.11	ReleaseSW (ACT, DIR)	61
9.2.12	GoHome	62
9.2.13	GoMark	62
9.2.14	ResetPos	62
9.2.15	ResetDevice	63
9.2.16	SoftStop	63
9.2.17	HardStop	63
9.2.18	SoftHiZ	63
9.2.19	HardHiZ	64
9.2.20	GetStatus	64
<b>10</b>	<b>Package mechanical data</b>	<b>65</b>
<b>11</b>	<b>Revision history</b>	<b>69</b>

## List of tables

Table 1.	Device summary . . . . .	1
Table 2.	Absolute maximum ratings . . . . .	9
Table 3.	Recommended operating conditions . . . . .	10
Table 4.	Thermal data . . . . .	10
Table 5.	Electrical characteristics . . . . .	11
Table 6.	Pin description . . . . .	17
Table 7.	Typical application values . . . . .	19
Table 8.	CL values according to external oscillator frequency . . . . .	28
Table 9.	Registers map . . . . .	40
Table 10.	EL_POS register . . . . .	41
Table 11.	MIN_SPEED register . . . . .	43
Table 12.	Voltage amplitude regulation registers . . . . .	44
Table 13.	Winding resistance thermal drift compensation coefficient . . . . .	45
Table 14.	ADC_OUT value and motor supply voltage compensation feature . . . . .	46
Table 15.	Overcurrent detection threshold . . . . .	46
Table 16.	Stall detection threshold . . . . .	47
Table 17.	STEP_MODE register . . . . .	47
Table 18.	Step mode selection . . . . .	47
Table 19.	SYNC output frequency . . . . .	48
Table 20.	SYNC signal source . . . . .	48
Table 21.	ALARM_EN register . . . . .	49
Table 22.	CONFIG register . . . . .	49
Table 23.	Oscillator management . . . . .	49
Table 24.	External switch hard stop interrupt mode . . . . .	50
Table 25.	Overcurrent event . . . . .	50
Table 26.	Programmable power bridge output slew rate values . . . . .	51
Table 27.	Motor supply voltage compensation enable . . . . .	51
Table 28.	PWM frequency: integer division factor . . . . .	51
Table 29.	PWM frequency: multiplication factor . . . . .	52
Table 30.	Available PWM frequencies [kHz]: 8-MHz oscillator frequency . . . . .	52
Table 31.	Available PWM frequencies [kHz]: 16-MHz oscillator frequency . . . . .	52
Table 32.	Available PWM frequencies [kHz]: 24-MHz oscillator frequency . . . . .	53
Table 33.	Available PWM frequencies [kHz]: 32-MHz oscillator frequency . . . . .	53
Table 34.	STATUS register . . . . .	54
Table 35.	STATUS register DIR bit . . . . .	54
Table 36.	STATUS register MOT_STATE bits . . . . .	55
Table 37.	Application commands . . . . .	55
Table 38.	Nop command structure . . . . .	57
Table 39.	SetParam command structure . . . . .	57
Table 40.	GetParam command structure . . . . .	58
Table 41.	Run command structure . . . . .	58
Table 42.	Stepclock command structure . . . . .	59
Table 43.	Move command structure . . . . .	59
Table 44.	GoTo command structure . . . . .	60
Table 45.	GoTo_DIR command structure . . . . .	60
Table 46.	GoUntil command structure . . . . .	61
Table 47.	ReleaseSW command structure . . . . .	61
Table 48.	GoHome command structure . . . . .	62

---

Table 49.	GoMark command structure . . . . .	62
Table 50.	ResetPos command structure . . . . .	62
Table 51.	ResetDevice command structure . . . . .	63
Table 52.	SoftStop command structure . . . . .	63
Table 53.	HardStop command structure . . . . .	63
Table 54.	SoftHiZ command structure . . . . .	63
Table 55.	HardHiZ command structure . . . . .	64
Table 56.	GetStatus command structure . . . . .	64
Table 57.	HTSSOP28 mechanical data . . . . .	65
Table 58.	POWERSO36 mechanical data . . . . .	67
Table 59.	Revision history . . . . .	69

## List of figures

Figure 1.	Block diagram . . . . .	8
Figure 2.	HTSSOP28 pin connection (top view) . . . . .	16
Figure 3.	POWERSO36 pin connection (top view) . . . . .	16
Figure 4.	Bipolar stepper motor control application using L6470 . . . . .	20
Figure 5.	Charge pump circuitry . . . . .	22
Figure 6.	Normal mode and microstepping (128 microsteps) . . . . .	22
Figure 7.	Automatic full-step switching . . . . .	23
Figure 8.	Speed profile in infinite acceleration/deceleration mode . . . . .	24
Figure 9.	Constant speed command examples . . . . .	25
Figure 10.	Positioning command examples . . . . .	25
Figure 11.	Motion command examples . . . . .	26
Figure 12.	OSCIN and OSCOUT pin configuration . . . . .	28
Figure 13.	External switch connection . . . . .	31
Figure 14.	Internal 3 V linear regulator . . . . .	32
Figure 15.	Current distortion and compensation . . . . .	35
Figure 16.	BEMF compensation curve . . . . .	36
Figure 17.	Motor supply voltage compensation circuit . . . . .	37
Figure 18.	SPI timings diagram . . . . .	38
Figure 19.	Daisy chain configuration . . . . .	39
Figure 20.	Command with 3-byte argument . . . . .	56
Figure 21.	Command with 3-byte response . . . . .	56
Figure 22.	Command response aborted . . . . .	57
Figure 23.	HTSSOP28 mechanical data . . . . .	66
Figure 24.	POWERSO36 drawings . . . . .	68

# 1 Block diagram

Figure 1. Block diagram

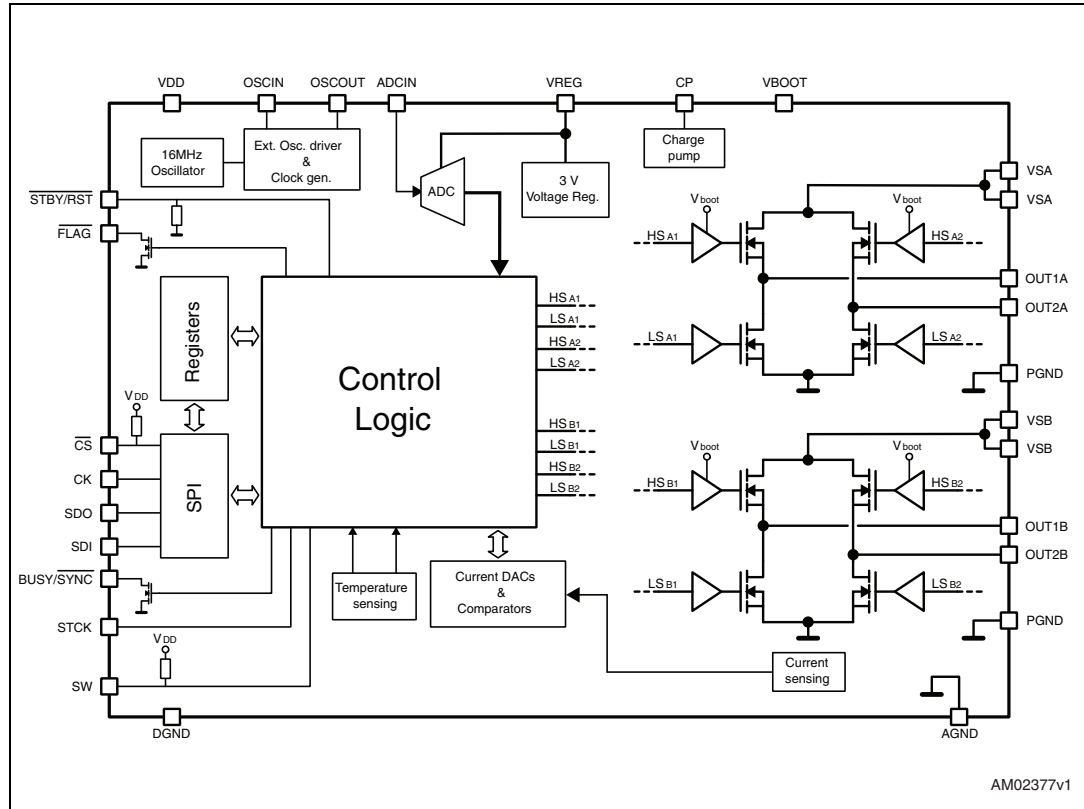

## 2 Electrical data

### 2.1 Absolute maximum ratings

**Table 2. Absolute maximum ratings**

Symbol	Parameter	Test condition	Value	Unit
$V_{DD}$	Logic interface supply voltage		5.5	V
$V_S$	Motor supply voltage	$V_{SA} = V_{SB} = V_S$	48	V
$V_{GND, diff}$	Differential voltage between AGND, PGND and DGND		$\pm 0.3$	V
$V_{boot}$	Bootstrap peak voltage		55	V
$V_{REG}$	Internal voltage regulator output pin and logic supply voltage		3.6	V
$V_{ADCIN}$	Integrated ADC input voltage range (ADCIN pin)		-0.3 to +3.6	V
$V_{OSC}$	OSCIN and OSCOUT pin voltage range		-0.3 to +3.6	V
$V_{out, diff}$	Differential voltage between $V_{SA}$ , OUT1 <sub>A</sub> , OUT2 <sub>A</sub> , PGND and $V_{SB}$ , OUT1 <sub>B</sub> , OUT2 <sub>B</sub> , PGND pins	$V_{SA} = V_{SB} = V_S$	48	V
$V_{LOGIC}$	Logic inputs voltage range		-0.3 to +5.5	V
$I_{out}^{(1)}$	R.m.s. output current		3	A
$I_{out, peak}^{(1)}$	Pulsed output current	$T_{PULSE} < 1 \text{ ms}$	7	A
$T_{OP}$	Operating junction temperature		150	°C
$T_s$	Storage temperature range		-55 to 150	°C
$P_{tot}$	Total power dissipation ( $T_A = 25 \text{ °C}$ ) <sup>(2)</sup>		5	W

1. Maximum output current limit is related to metal connection and bonding characteristics. Actual limit must satisfy maximum thermal dissipation constraints.
2. HTSSOP28 mounted on EVAL6470H.

## 2.2 Recommended operating conditions

**Table 3. Recommended operating conditions**

Symbol	Parameter	Test condition	Value			Unit
V <sub>DD</sub>	Logic interface supply voltage	3.3 V logic outputs		3.3		V
		5 V logic outputs		5		
V <sub>S</sub>	Motor supply voltage	V <sub>SA</sub> = V <sub>SB</sub> = V <sub>S</sub>	8		45	V
V <sub>out_diff</sub>	Differential voltage between V <sub>SA</sub> , OUT1 <sub>A</sub> , OUT2 <sub>A</sub> , PGND and V <sub>SB</sub> , OUT1 <sub>B</sub> , OUT2 <sub>B</sub> , PGND pins	V <sub>SA</sub> = V <sub>SB</sub> = V <sub>S</sub>			45	V
V <sub>REG,in</sub>	Logic supply voltage	V <sub>REG</sub> voltage imposed by external source	3.2	3.3		V
V <sub>ADC</sub>	Integrated ADC input voltage (ADCIN pin)		0		V <sub>REG</sub>	V
T <sub>j</sub>	Operating junction temperature		- 25		125	°C

## 2.3 Thermal data

**Table 4. Thermal data**

Symbol	Parameter	Package	Typ.	Unit
R <sub>thJA</sub>	Thermal resistance junction-ambient	HTSSOP28 <sup>(1)</sup>	22	°C/W
		POWERSO36 <sup>(2)</sup>	12	

1. HTSSOP28 mounted on EVAL6470H rev 1.0 board: four-layer FR4 PCB with a dissipating copper surface of about 40 cm<sup>2</sup> on each layer and 15 via holes below the IC.
2. POWERSO36 mounted on EVAL6470PD rev 1.0 board: four-layer FR4 PCB with a dissipating copper surface of about 40 cm<sup>2</sup> on each layer and 22 via holes below the IC.

### 3 Electrical characteristics

$V_{SA} = V_{SB} = 36\text{ V}$ ;  $V_{DD} = 3.3\text{ V}$ ; internal 3 V regulator;  $T_J = 25\text{ °C}$ , unless otherwise specified.

**Table 5. Electrical characteristics**

Symbol	Parameter	Test condition	Min.	Typ.	Max.	Unit
<b>General</b>						
$V_{SthOn}$	$V_S$ UVLO turn-on threshold		7.5	8.2	8.9	V
$V_{SthOff}$	$V_S$ UVLO turn-off threshold		6.6	7.2	7.8	V
$V_{SthHyst}$	$V_S$ UVLO threshold hysteresis		0.7	1	1.3	V
$I_q$	Quiescent motor supply current	Internal oscillator selected; VREG = 3.3 V ext; CP floating		0.5	0.65	mA
$T_{j(WRN)}$	Thermal warning temperature			130		°C
$T_{j(SD)}$	Thermal shutdown temperature			160		°C
<b>Charge pump</b>						
$V_{pump}$	Voltage swing for charge pump oscillator			10		V
$f_{pump,min}$	Minimum charge pump oscillator frequency (1)			660		kHz
$f_{pump,max}$	Maximum charge pump oscillator frequency (1)			800		kHz
$I_{boot}$	Average boot current	$f_{sw,A} = f_{sw,B} = 15.6\text{ kHz}$ POW_SR = '10'		1.1	1.4	mA
<b>Output DMOS transistor</b>						
$R_{DS(on)}$	High-side switch on-resistance	$T_j = 25\text{ °C}$ , $I_{out} = 3\text{ A}$		0.37		Ω
		$T_j = 125\text{ °C}$ , (2) $I_{out} = 3\text{ A}$		0.51		
$R_{DS(on)}$	Low-side switch on-resistance	$T_j = 25\text{ °C}$ , $I_{out} = 3\text{ A}$		0.18		Ω
		$T_j = 125\text{ °C}$ , (2) $I_{out} = 3\text{ A}$		0.23		
$I_{DSS}$	Leakage current	OUT = $V_S$			3.1	mA
		OUT = GND	-0.3			
$t_r$	Rise time (3)	POW_SR = '00', $I_{out} = +1\text{ A}$		100		ns
		POW_SR = '00', $I_{out} = -1\text{ A}$		80		
		POW_SR = '11', $I_{out} = \pm 1\text{ A}$		100		
		POW_SR = '10', $I_{out} = \pm 1\text{ A}$		200		
		POW_SR = '01', $I_{out} = \pm 1\text{ A}$		300		

**Table 5. Electrical characteristics (continued)**

Symbol	Parameter	Test condition	Min.	Typ.	Max.	Unit
$t_f$	Fall time <sup>(3)</sup>	POW_SR = '00'; $I_{out} = +1$ A		90		ns
		POW_SR = '00'; $I_{out} = -1$ A		110		
		POW_SR = '11', $I_{out} = \pm 1$ A		110		
		POW_SR = '10', $I_{out} = \pm 1$ A		260		
		POW_SR = '01', $I_{load} = \pm 1$ A		375		
$SR_{out\_r}$	Output rising slew rate	POW_SR = '00', $I_{out} = +1$ A		285		V/ $\mu$ s
		POW_SR = '00', $I_{out} = -1$ A		360		
		POW_SR = '11', $I_{out} = \pm 1$ A		285		
		POW_SR = '10', $I_{out} = \pm 1$ A		150		
		POW_SR = '01', $I_{out} = \pm 1$ A		95		
$SR_{out\_f}$	Output falling slew rate	POW_SR = '00', $I_{out} = +1$ A		320		V/ $\mu$ s
		POW_SR = '00', $I_{out} = -1$ A		260		
		POW_SR = '11', $I_{out} = \pm 1$ A		260		
		POW_SR = '10', $I_{out} = \pm 1$ A		110		
		POW_SR = '01', $I_{out} = \pm 1$ A		75		
<b>Deadtime and blanking</b>						
$t_{DT}$	Deadtime <sup>(1)</sup>	POW_SR = '00'		250		ns
		POW_SR = '11', $f_{OSC} = 16$ MHz		375		
		POW_SR = '10', $f_{OSC} = 16$ MHz		625		
		POW_SR = '01', $f_{OSC} = 16$ MHz		875		
$t_{blank}$	Blanking time <sup>(1)</sup>	POW_SR = '00'		250		ns
		POW_SR = '11', $f_{OSC} = 16$ MHz		375		
		POW_SR = '10', $f_{OSC} = 16$ MHz		625		
		POW_SR = '01', $f_{OSC} = 16$ MHz		875		
<b>Source-drain diodes</b>						
$V_{SD,HS}$	High-side diode forward ON voltage	$I_{out} = 1$ A		1	1.1	V
$V_{SD,LS}$	Low-side diode forward ON voltage	$I_{out} = 1$ A		1	1.1	V
$t_{rrHS}$	High-side diode reverse recovery time	$I_{out} = 1$ A		30		ns
$t_{rrLS}$	Low-side diode reverse recovery time	$I_{out} = 1$ A		100		ns

Table 5. Electrical characteristics (continued)

Symbol	Parameter	Test condition	Min.	Typ.	Max.	Unit
<b>Logic inputs and outputs</b>						
$V_{IL}$	Low logic level input voltage				0.8	V
$V_{IH}$	High logic level input voltage		2			V
$I_{IH}$	High logic level input current <sup>(4)</sup>	$V_{IN} = 5\text{ V}$			1	$\mu\text{A}$
$I_{IL}$	Low logic level input current <sup>(5)</sup>	$V_{IN} = 0\text{ V}$	-1			$\mu\text{A}$
$V_{OL}$	Low logic level output voltage <sup>(6)</sup>	$V_{DD} = 3.3\text{ V}, I_{OL} = 4\text{ mA}$			0.3	V
		$V_{DD} = 5\text{ V}, I_{OL} = 4\text{ mA}$			0.3	
$V_{OH}$	High logic level output voltage	$V_{DD} = 3.3\text{ V}, I_{OH} = 4\text{ mA}$	2.4			V
		$V_{DD} = 5\text{ V}, I_{OH} = 4\text{ mA}$	4.7			
$R_{PU}$ $R_{PD}$	CS pull-up and STBY pull-down resistors	$\overline{CS} = \text{GND};$ $\overline{STBY}/\overline{RST} = 5\text{ V}$	335	430	565	$\text{k}\Omega$
$I_{logic}$	Internal logic supply current	3.3 V $V_{REG}$ externally supplied, internal oscillator		3.7	4.3	mA
$I_{logic,STBY}$	Standby mode internal logic supply current	3.3 V $V_{REG}$ externally supplied		2	2.5	$\mu\text{A}$
$f_{STCK}$	Step-clock input frequency				2	MHz
<b>Internal oscillator and external oscillator driver</b>						
$f_{osc,i}$	Internal oscillator frequency	$T_j = 25\text{ }^\circ\text{C},$ $V_{REG} = 3.3\text{ V}$	-3%	16	+3%	MHz
$f_{osc,e}$	Programmable external oscillator frequency		8		32	MHz
$V_{OSCOUTH}$	OSCOUT clock source high level voltage	Internal oscillator 3.3 V $V_{REG}$ externally supplied; $I_{OSCOUT} = 4\text{ mA}$	2.4			V
$V_{OSCOU TL}$	OSCOUT clock source low level voltage	Internal oscillator 3.3 V $V_{REG}$ externally supplied; $I_{OSCOUT} = 4\text{ mA}$			0.3	V
$t_{rOSCOUT}$ $t_{fOSCOUT}$	OSCOUT clock source rise and fall time	Internal oscillator			20	ns
$t_{extosc}$	Internal to external oscillator switching delay			3		ms
$t_{intosc}$	External to internal oscillator switching delay			1.5		$\mu\text{s}$
<b>SPI</b>						
$f_{CK,MAX}$	Maximum SPI clock frequency <sup>(7)</sup>		5			MHz
$t_{rCK}$ $t_{fCK}$	SPI clock rise and fall time <sup>(7)</sup>	$C_L = 30\text{ pF}$			25	ns
$t_{hCK}$ $t_{lCK}$	SPI clock high and low time <sup>(7)</sup>		75			ns
$t_{setCS}$	Chip select setup time <sup>(7)</sup>		350			ns

Table 5. Electrical characteristics (continued)

Symbol	Parameter	Test condition	Min.	Typ.	Max.	Unit
$t_{\text{holCS}}$	Chip select hold time <sup>(7)</sup>		10			ns
$t_{\text{disCS}}$	Deselect time <sup>(7)</sup>		800			ns
$t_{\text{setSDI}}$	Data input setup time <sup>(7)</sup>		25			ns
$t_{\text{holSDI}}$	Data input hold time <sup>(7)</sup>		20			ns
$t_{\text{enSDO}}$	Data output enable time <sup>(7)</sup>				38	ns
$t_{\text{disSDO}}$	Data output disable time <sup>(7)</sup>				47	ns
$t_{\text{vSDO}}$	Data output valid time <sup>(7)</sup>				57	ns
$t_{\text{holSDO}}$	Data output hold time <sup>(7)</sup>		37			ns
<b>Switch input (SW)</b>						
$R_{\text{PUSW}}$	SW input pull-up resistance	SW = GND	60	85	110	k $\Omega$
<b>PWM modulators</b>						
$f_{\text{PWM}}$	Programmable PWM frequency <sup>(1)</sup>	$f_{\text{osc}} = 16 \text{ MHz}$	2.8		62.5	kHz
		$f_{\text{osc}} = 32 \text{ MHz}$	5.6		125	
$N_{\text{PWM}}$	PWM resolution			8		bit
<b>Stall detection</b>						
$I_{\text{STALL,MAX}}$	Maximum programmable stall threshold	STALL_TH = '1111111'		4		A
$I_{\text{STALL,MIN}}$	Minimum programmable stall threshold	STALL_TH = '0000000'		31.2 5		mA
$I_{\text{STALL,RES}}$	Programmable stall threshold resolution			31.2 5		mA
<b>Overcurrent protection</b>						
$I_{\text{OCD,MAX}}$	Maximum programmable overcurrent detection threshold	OCD_TH = '1111'		6		A
$I_{\text{OCD,MIN}}$	Minimum programmable overcurrent detection threshold	OCD_TH = '0000'		0.37 5		A
$I_{\text{OCD,RES}}$	Programmable overcurrent detection threshold resolution			0.37 5		A
$t_{\text{OCD,Flag}}$	OCD to flag signal delay time	$di_{\text{out}}/dt = 350 \text{ A}/\mu\text{s}$		650	1000	ns
$t_{\text{OCD,SD}}$	OCD to shutdown delay time	$di_{\text{out}}/dt = 350 \text{ A}/\mu\text{s}$ POW_SR = '10'		600		ns
<b>Standby</b>						
$I_{\text{qSTBY}}$	Quiescent motor supply current in standby conditions	$V_{\text{S}} = 8 \text{ V}$		26	34	$\mu\text{A}$
		$V_{\text{S}} = 36 \text{ V}$		30	36	
$t_{\text{STBY,min}}$	Minimum standby time			10		$\mu\text{s}$
$t_{\text{logicwu}}$	Logic power-on and wake-up time			38	45	$\mu\text{s}$

Table 5. Electrical characteristics (continued)

Symbol	Parameter	Test condition	Min.	Typ.	Max.	Unit
$t_{cpwu}$	Charge pump power-on and wake-up time	Power bridges disabled, $C_p = 10 \text{ nF}$ , $C_{boot} = 220 \text{ nF}$		650		$\mu\text{s}$
<b>Internal voltage regulator</b>						
$V_{REG}$	Voltage regulator output voltage		2.9	3	3.2	V
$I_{REG}$	Voltage regulator output current				40	mA
$V_{REG, drop}$	Voltage regulator output voltage drop	$I_{REG} = 40 \text{ mA}$		50		mV
$I_{REG, STBY}$	Voltage regulator standby output current				10	mA
<b>Integrated analog-to-digital converter</b>						
$N_{ADC}$	Analog-to-digital converter resolution			5		bit
$V_{ADC, ref}$	Analog-to-digital converter reference voltage			$V_{REG}$		V
$f_S$	Analog-to-digital converter sampling frequency			$f_{PWM}$		kHz

1. Accuracy depends on oscillator frequency accuracy.
2. Tested at 25 °C in a restricted range and guaranteed by characterization.
3. Rise and fall time depends on motor supply voltage value. Refer to  $SR_{out}$  values in order to evaluate the actual rise and fall time.
4. Not valid for  $\overline{STBY/RST}$  pin which has internal pull-down resistor.
5. Not valid for SW and CS pins which have internal pull-up resistors.
6.  $\overline{FLAG}$ ,  $\overline{BUSY}$  and SYNC open drain outputs included.
7. See [Figure 18](#) – SPI timings diagram for details.

# 4 Pin connection

**Figure 2. HTSSOP28 pin connection (top view)**

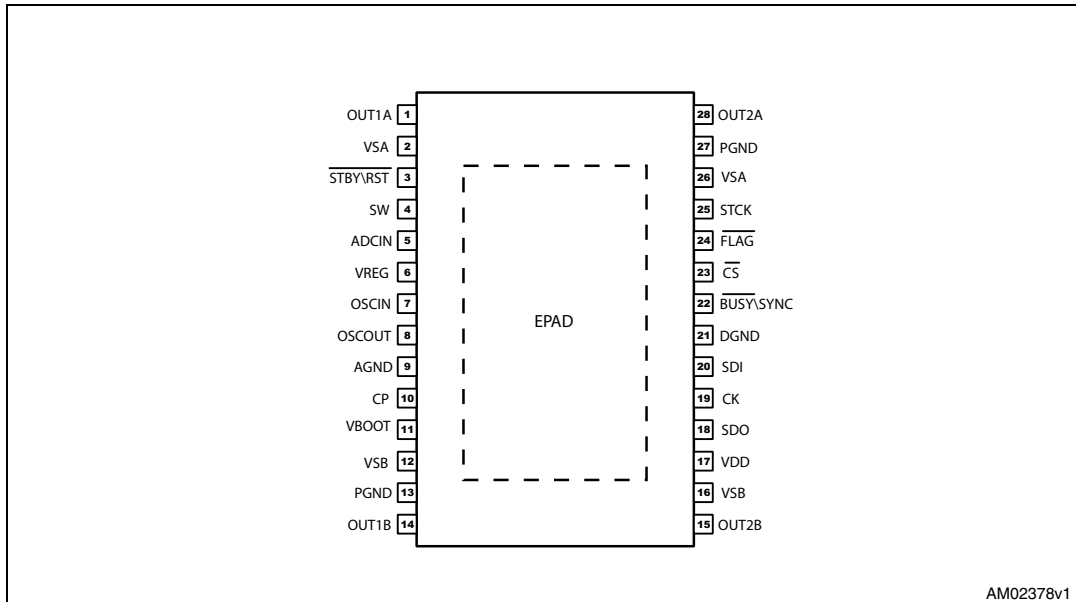

**Figure 3. POWERSO36 pin connection (top view)**

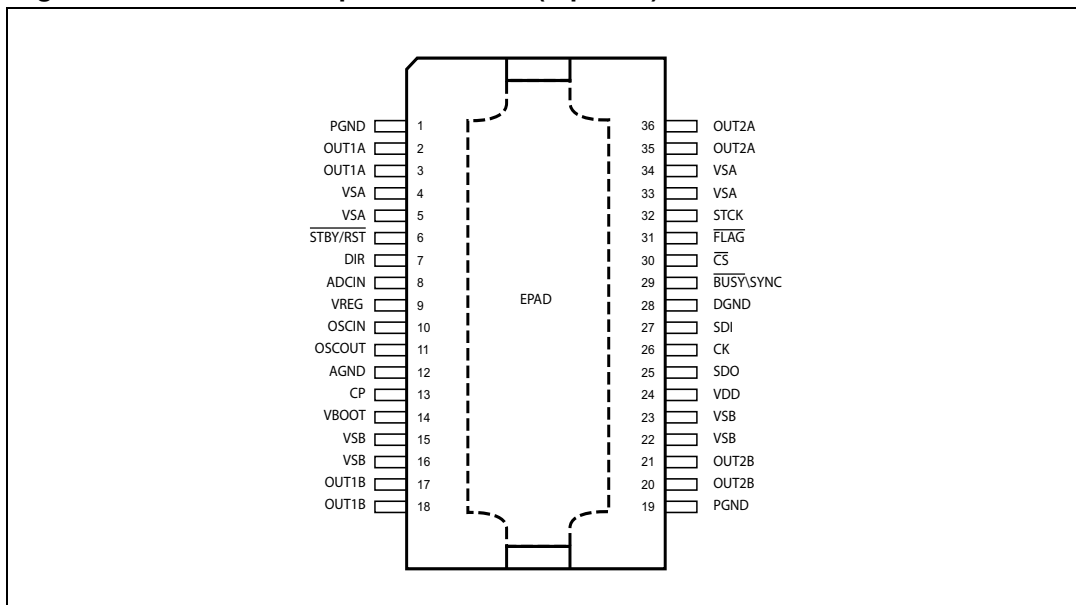

## 4.1 Pin list

Table 6. Pin description

No.		Name	Type	Function
HTSSOP	POWERSO			
17	24	VDD	Power	Logic outputs supply voltage (pull-up reference)
6	9	VREG	Power	Internal 3 V voltage regulator output and 3.3 V external logic supply
7	10	OSCIN	Analog input	Oscillator pin 1. To connect an external oscillator or clock source. If this pin is unused, it should be left floating.
8	11	OSCOU	Analog output	Oscillator pin 2. To connect an external oscillator. When the internal oscillator is used this pin can supply 2/4/8/16 MHz. If this pin is unused, it should be left floating.
10	13	CP	Output	Charge pump oscillator output
11	14	VBOOT	Supply voltage	Bootstrap voltage needed for driving the high-side power DMOS of both bridges (A and B)
5	8	ADCIN	Analog input	Internal analog-to-digital converter input
2, 26	4, 5, 33, 34	VSA	Power supply	Full bridge A power supply pin. It must be connected to VSB.
12, 16	15, 16, 22, 23	VSB	Power supply	Full bridge B power supply pin. It must be connected to VSA.
27, 13	1, 19	PGND	Ground	Power ground pin
1	2, 3	OUT1A	Power output	Full bridge A output 1
28	35, 36	OUT2A	Power output	Full bridge A output 2
14	17, 18	OUT1B	Power output	Full bridge B output 1
15	20, 21	OUT2B	Power output	Full bridge B output 2
9	12	AGND	Ground	Analog ground.
4	7	SW	Logical input	External switch input pin. If not used the pin should be connected to VDD.
21	28	DGND	Ground	Digital ground
22	29	$\overline{\text{BUSY}}/\text{SYNC}$	Open drain output	By default, this BUSY pin is forced low when the device is performing a command. Otherwise the pin can be configured to generate a synchronization signal.
18	25	SDO	Logic output	Data output pin for serial interface
20	27	SDI	Logic input	Data input pin for serial interface
19	26	CK	Logic input	Serial interface clock
23	30	$\overline{\text{CS}}$	Logic input	Chip select input pin for serial interface

Table 6. Pin description (continued)

No.		Name	Type	Function
HTSSOP	POWERSO			
24	31	$\overline{\text{FLAG}}$	Open drain output	Status flag pin. An internal open drain transistor can pull the pin to GND when a programmed alarm condition occurs (step loss, OCD, thermal pre-warning or shutdown, UVLO, wrong command, non-performable command)
3	6	$\overline{\text{STBY}}\overline{\text{RST}}$	Logic input	Standby and reset pin. LOW logic level resets the logic and puts the device into Standby mode. If not used, it should be connected to VDD.
25	32	STCK	Logic input	Step-clock input
EPAD	EPAD	Exposed pad	Ground	Internally connected to PGND, AGND and DGND pins

## 5 Typical applications

Table 7. Typical application values

Name	Value
$C_{VS}$	220 nF
$C_{VSPOL}$	100 $\mu$ F
$C_{REG}$	100 nF
$C_{REGPOL}$	47 $\mu$ F
$C_{DD}$	100 nF
$C_{DDPOL}$	10 $\mu$ F
D1	Charge pump diodes
$C_{BOOT}$	220 nF
$C_{FLY}$	10 nF
$R_{PU}$	39 k $\Omega$
$R_{SW}$	100 $\Omega$
$C_{SW}$	10 nF
$R_A$	2.7 k $\Omega$ (VS = 36 V)
$R_B$	62 k $\Omega$ (VS = 36 V)

Figure 4. Bipolar stepper motor control application using L6470

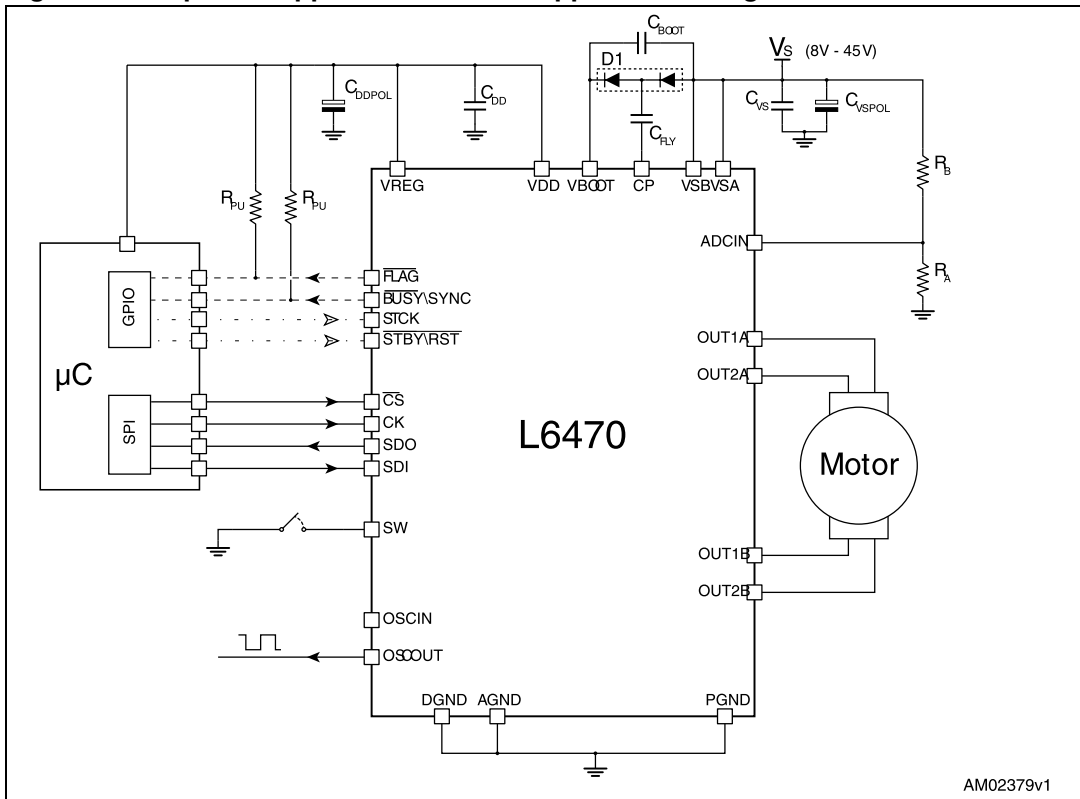

## 6 Functional description

### 6.1 Device power-up

At power-up end, the device state is the following:

- Registers are set to default
- Internal logic is driven by internal oscillator and a 2 MHz clock is provided by the OSCOUT pin
- Bridges are disabled (High Z)
- UVLO bit in the STATUS register is forced low (fail condition)
- FLAG output is forced low.

During power-up, the device is under reset (all logic IOs disabled and power bridges in high impedance state) until the following conditions are satisfied:

- $V_S$  is greater than  $V_{SthOn}$
- $V_{REG}$  is greater than  $V_{REGth} = 2.8$  V typical
- Internal oscillator is operative.

Any motion command makes the device exit from High Z state (HardStop and SoftStop included).

### 6.2 Logic I/O

Pins  $\overline{CS}$ , CK, SDI, STCK, SW and  $\overline{STBY}\overline{RST}$  are TTL/CMOS 3.3 V - 5 V compatible logic inputs.

Pin SDO is a TTL/CMOS compatible logic output. VDD pin voltage sets the logic output pin voltage range; when it is connected to VREG or 3.3 V external supply voltage, the output is 3.3 V compatible. When VDD is connected to a 5 V supply voltage, SDO is 5 V compatible.

VDD is not internally connected to  $V_{REG}$ , an external connection is always needed.

A 10  $\mu$ F capacitor should be connected to the VDD pin in order to obtain a proper operation.

Pins  $\overline{FLAG}$  and  $\overline{BUSY}\overline{SYNC}$  are open drain outputs.

### 6.3 Charge pump

To ensure the correct driving of the high-side integrated MOSFETs, a voltage higher than the motor power supply voltage needs to be applied to the VBOOT pin. The high-side gate driver supply voltage,  $V_{boot}$ , is obtained through an oscillator and a few external components realizing a charge pump (see [Figure 5](#)).

Figure 5. Charge pump circuitry

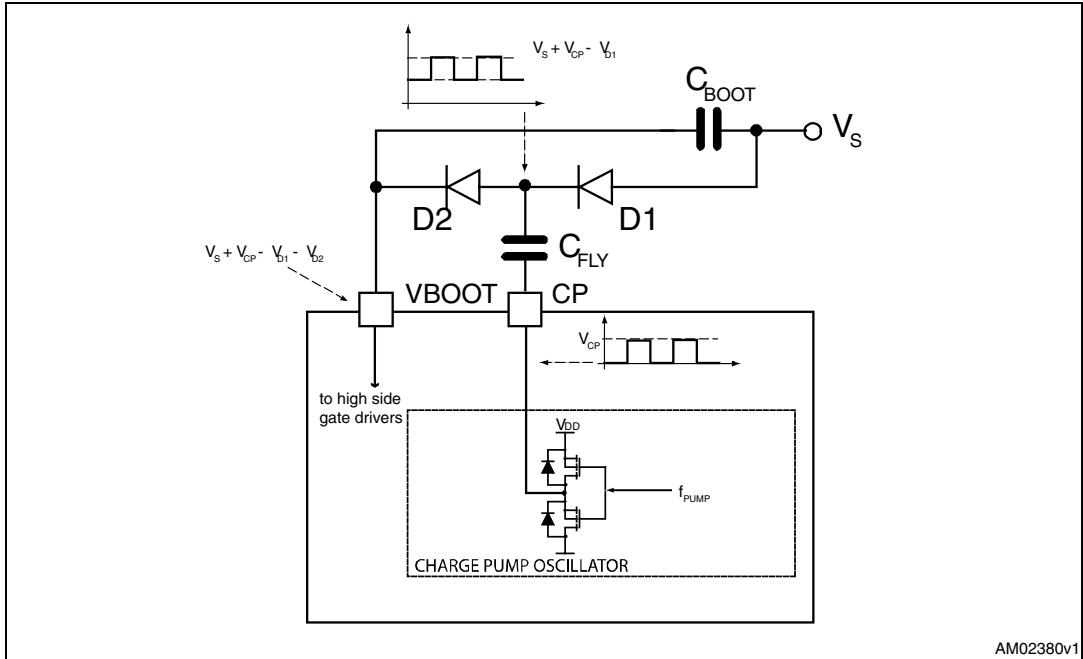

## 6.4 Microstepping

The driver is able to divide the single step into up to 128 microsteps. Stepping mode can be programmed by the STEP\_SEL parameter in the STEP\_MODE register (see [Table 18](#)).

Step mode can only be changed when bridges are disabled. Every time the step mode is changed the electrical position (i.e. the point of microstepping sinewave that is generated) is reset to the first microstep and the absolute position counter value (see [Section 6.5](#)) becomes meaningless.

Figure 6. Normal mode and microstepping (128 microsteps)

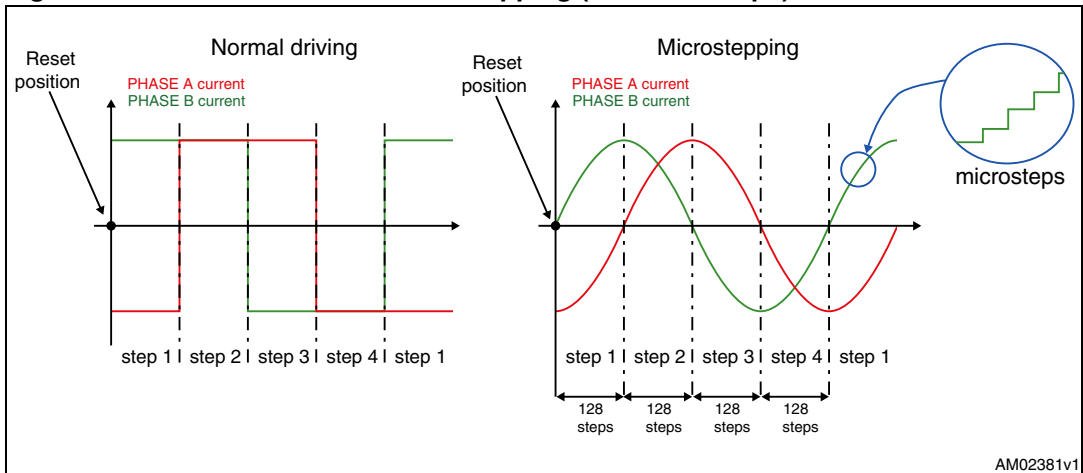

### 6.4.1 Automatic full-step mode

When motor speed is greater than a programmable full-step speed threshold, the L6470 switches automatically to Full-step mode (see [Figure 7](#)); the driving mode returns to microstepping when motor speed decreases below the full-step speed threshold. The full-step speed threshold is set through the FS\_SPD register (see [Section 9.1.9](#)).

**Figure 7. Automatic full-step switching**

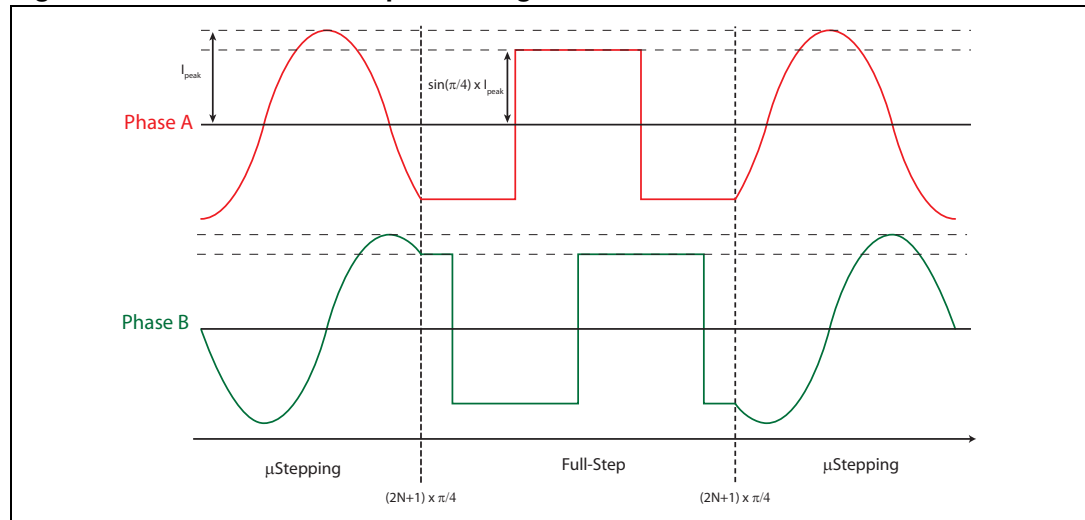

### 6.5 Absolute position counter

An internal 22-bit register (ABS\_POS) records the motor motion according to the selected step mode; the stored value unit is equal to the selected step mode (full, half, quarter, etc.). The position range is from  $-2^{21}$  to  $+2^{21}-1$  ( $\mu$ )steps (see [Section 9.1.1](#)).

### 6.6 Programmable speed profiles

The user can easily program a customized speed profile defining independently acceleration, deceleration, maximum and minimum speed values by the ACC, DEC, MAX\_SPEED and MIN\_SPEED registers respectively (see [Section 9.1.5](#), [9.1.6](#), [9.1.7](#) and [9.1.8](#)).

When a command is sent to the device, the integrated logic generates the microstep frequency profile that performs a motor motion compliant to speed profile boundaries.

All acceleration parameters are expressed in  $\text{step}/\text{tick}^2$  and all speed parameters are expressed in  $\text{step}/\text{tick}$ ; the unit of measurement does not depend on the selected step mode. Acceleration and deceleration parameters range from  $2^{-40}$  to  $(2^{12}-2) \cdot 2^{-40}$   $\text{step}/\text{tick}^2$  (equivalent to 14.55 to 59590  $\text{step}/\text{s}^2$ ).

The minimum speed parameter ranges from 0 to  $(2^{12}-1) \cdot 2^{-24}$   $\text{step}/\text{tick}$  (equivalent to 0 to 976.3  $\text{step}/\text{s}$ ).

The maximum speed parameter ranges from  $2^{-18}$  to  $(2^{10}-1) \cdot 2^{-18}$   $\text{step}/\text{tick}$  (equivalent to 15.25 to 15610  $\text{step}/\text{s}$ ).

### 6.6.1 Infinite acceleration/deceleration mode

When the ACC register value is set to max. (0xFF), the system works in “infinite acceleration mode”: acceleration and deceleration phases are totally skipped, as shown in [Figure 8](#).

It is not possible to skip the acceleration or deceleration phase independently.

**Figure 8. Speed profile in infinite acceleration/deceleration mode**

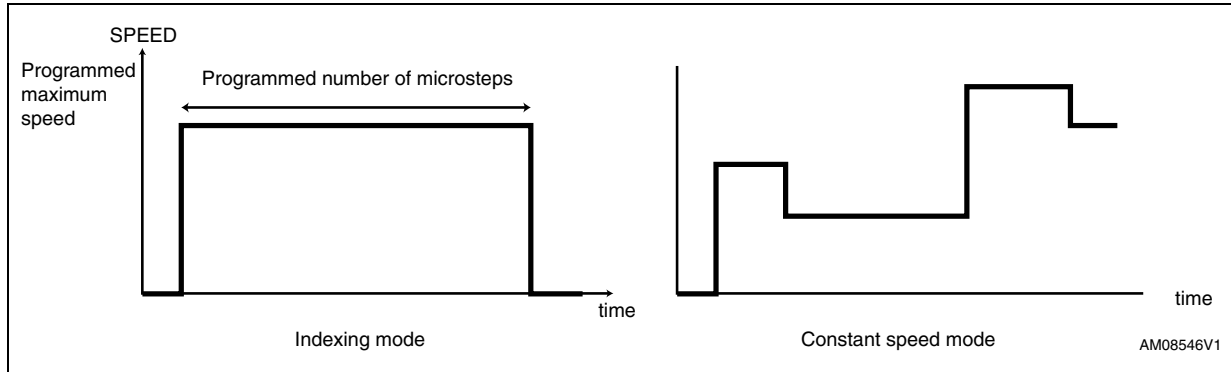

## 6.7 Motor control commands

The L6470 can accept different types of commands:

- constant speed commands (Run, GoUntil, ReleaseSW)
- absolute positioning commands (GoTo, GoTo\_DIR, GoHome, GoMark)
- motion commands (Move)
- stop commands (SoftStop, HardStop, SoftHiz, HardHiz).

For detailed command descriptions refer to [Section 9.2 on page 55](#).

### 6.7.1 Constant speed commands

A constant speed command produces a motion in order to reach and maintain a user-defined target speed starting from the programmed minimum speed (set in the MIN\_SPEED register) and with the programmed acceleration/deceleration value (set in the ACC and DEC registers). A new constant speed command can be requested anytime.

**Figure 9. Constant speed command examples**

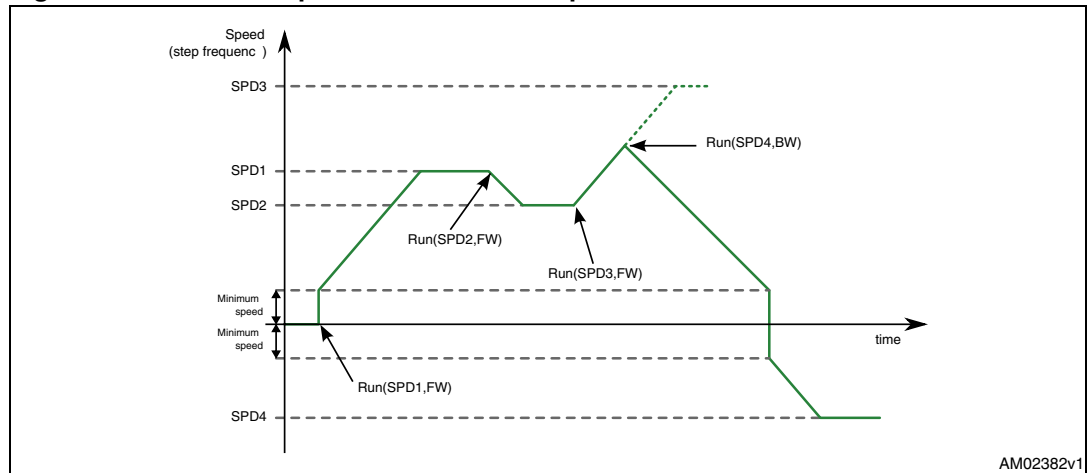

**6.7.2 Positioning commands**

An absolute positioning command produces a motion in order to reach a user-defined position that is sent to the device together with the command. The position can be reached performing the minimum path (minimum physical distance) or forcing a direction (see [Figure 10](#)).

The performed motor motion is compliant to programmed speed profile boundaries (acceleration, deceleration, minimum and maximum speed).

Note that with some speed profiles or positioning commands, the deceleration phase can start before the maximum speed is reached.

**Figure 10. Positioning command examples**

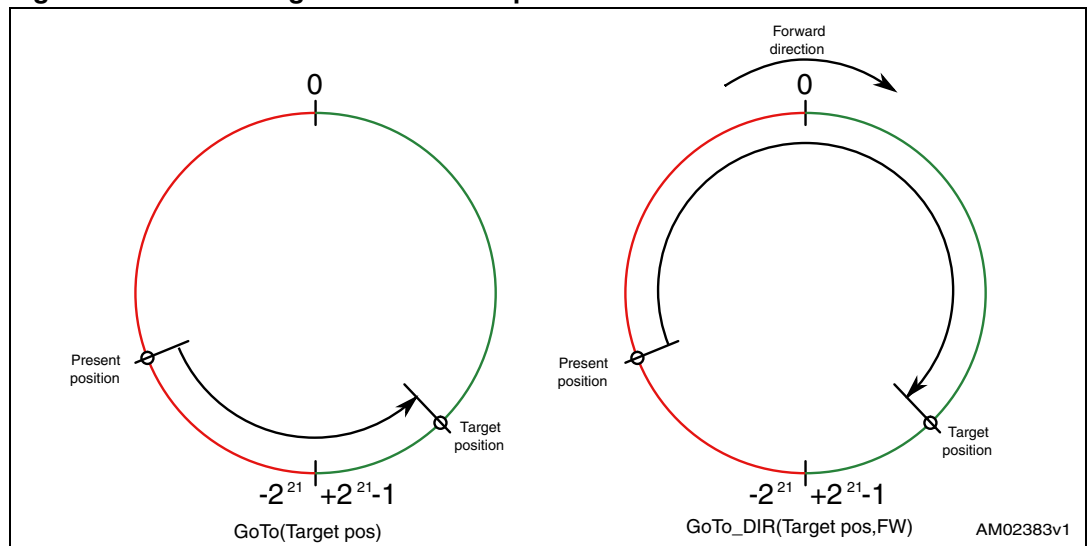

**6.7.3 Motion commands**

Motion commands produce a motion in order to perform a user-defined number of microsteps in a user-defined direction that are sent to the device together with the command (see [Figure 11](#)).

The performed motor motion is compliant to programmed speed profile boundaries (acceleration, deceleration, minimum and maximum speed).

Note that with some speed profiles or motion commands, the deceleration phase can start before the maximum speed is reached.

**Figure 11. Motion command examples**

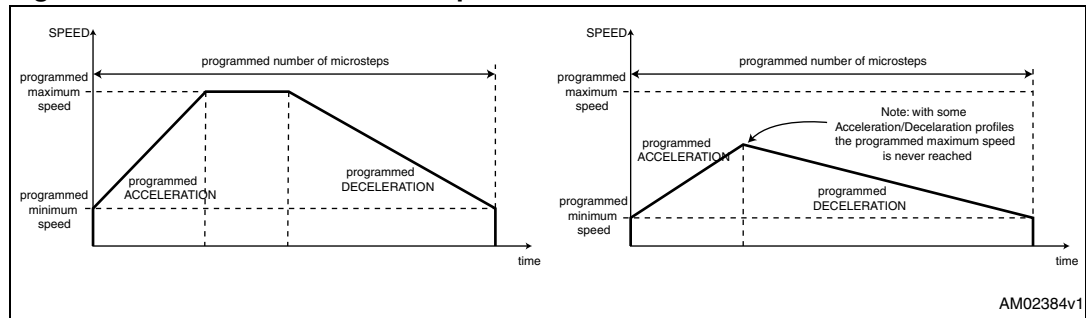

### 6.7.4 Stop commands

A stop command forces the motor to stop. Stop commands can be sent anytime.

The SoftStop command causes the motor to decelerate with programmed deceleration value until the MIN\_SPEED value is reached and then stops the motor keeping the rotor position (a holding torque is applied).

The HardStop command stops the motor instantly, ignoring deceleration constraints and keeping the rotor position (a holding torque is applied).

The SoftHiZ command causes the motor to decelerate with programmed deceleration value until the MIN\_SPEED value is reached and then forces the bridges in high impedance state (no holding torque is present).

The HardHiZ command instantly forces the bridges into high impedance state (no holding torque is present).

### 6.7.5 Step-clock mode

In Step-clock mode the motor motion is defined by the step-clock signal applied to the STCK pin. At each step-clock rising edge, the motor is moved one microstep in the programmed direction and the absolute position is consequently updated.

When the system is in Step-clock mode, the SCK\_MOD flag in the STATUS register is raised, the SPEED register is set to zero and motor status is considered stopped whatever the STCK signal frequency (MOT\_STATUS parameter in STATUS register equal to "00").

### 6.7.6 GoUntil and ReleaseSW commands

In most applications the power-up position of the stepper motor is undefined, so an initialization algorithm driving the motor to a known position is necessary.

The GoUntil and ReleaseSW commands can be used in combination with external switch input (see [Section 6.13](#)) to easily initialize the motor position.

The GoUntil command makes the motor run at the constant target speed until the SW input is forced low (falling edge). When this event occurs, one of the following actions can be performed:

- The ABS\_POS register is set to zero (home position) and the motor decelerates to zero speed (as a SoftStop command)
- The ABS\_POS register value is stored in the MARK register and the motor decelerates to zero speed (as a SoftStop command).

If the SW\_MODE bit of the CONFIG register is set to '0', the motor does not decelerate but it immediately stops (as a HardStop command).

The ReleaseSW command makes the motor run at the programmed minimum speed until the SW input is forced high (rising edge). When this event occurs, one of the following actions can be performed:

- The ABS\_POS register is set to zero (home position) and the motor immediately stops (as a HardStop command)
- The ABS\_POS register value is stored in the MARK register and the motor immediately stops (as a HardStop command).

If the programmed minimum speed is less than 5 step/s, the motor is driven at 5 step/s.

## 6.8 Internal oscillator and oscillator driver

The control logic clock can be supplied by the internal 16-MHz oscillator, an external oscillator (crystal or ceramic resonator) or a direct clock signal.

These working modes can be selected by EXT\_CLK and OSC\_SEL parameters in the CONFIG register (see [Table 23](#)).

At power-up the device starts using the internal oscillator and provides a 2-MHz clock signal on the OSCOUT pin.

---

**Attention:** In any case, before changing clock source configuration, a hardware reset is mandatory. Switching to different clock configurations during operation may cause unexpected behavior.

---

### 6.8.1 Internal oscillator

In this mode the internal oscillator is activated and OSCIN is unused. If the OSCOUT clock source is enabled, the OSCOUT pin provides a 2, 4, 8 or 16-MHz clock signal (according to OSC\_SEL value); it is otherwise unused (see [Figure 12](#)).

### 6.8.2 External clock source

Two types of external clock source can be selected: crystal/ceramic resonator or direct clock source. Four programmable clock frequencies are available for each external clock source: 8, 16, 24 and 32 MHz.

When an external crystal/resonator is selected, the OSCIN and OSCOUT pins are used to drive the crystal/resonator (see [Figure 12](#)). The crystal/resonator and load capacitors ( $C_L$ )

must be placed as close as possible to the pins. Refer to [Table 8](#) for the choice of load capacitor values according to the external oscillator frequency.

**Table 8. CL values according to external oscillator frequency**

Crystal/resonator freq. (1)	CL (2)
8 MHz	25 pF (ESR <sub>max</sub> = 80 Ω)
16 MHz	18 pF (ESR <sub>max</sub> = 50 Ω)
24 MHz	15 pF (ESR <sub>max</sub> = 40 Ω)
32 MHz	10 pF (ESR <sub>max</sub> = 40 Ω)

1. First harmonic resonance frequency.
2. Lower ESR value allows the driving of greater load capacitors.

If a direct clock source is used, it must be connected to the OSCIN pin and the OSCOUT pin supplies the inverted OSCIN signal (see [Figure 12](#)).

**Figure 12. OSCIN and OSCOUT pin configuration**

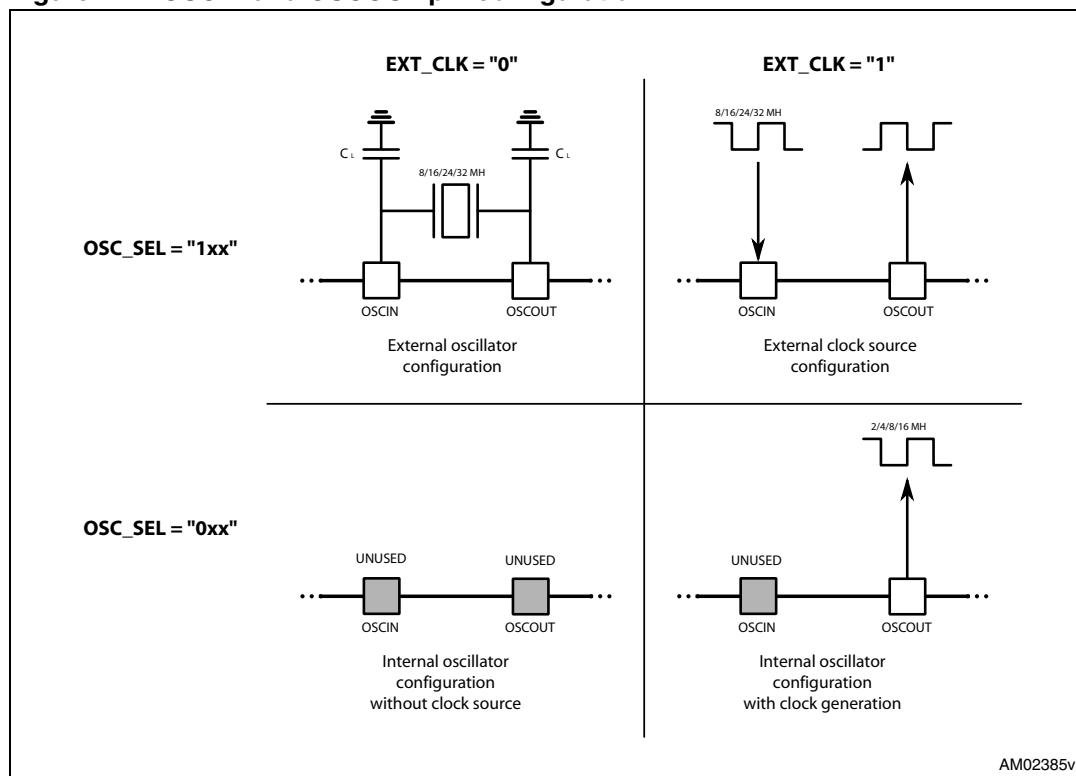

*Note:* When OSCIN is UNUSED, it should be left floating.  
 When OSCOUT is UNUSED, it should be left floating.

## 6.9 Overcurrent detection

When the current in any of the Power MOSFETs exceeds a programmed overcurrent threshold, the STATUS register OCD flag is forced low until the overcurrent event has

expired and a GetStatus command is sent to the IC (see [Section 9.1.22](#) and [9.1.17](#)). The overcurrent event expires when all the Power MOSFET currents fall below the programmed overcurrent threshold.

The overcurrent threshold can be programmed through the OCD\_TH register in one of 16 available values ranging from 375 mA to 6 A with steps of 375 mA (see [Table 9](#), [Section 9.1.17](#)).

It is possible to set whether an overcurrent event causes or not the MOSFET turn-off (bridges in high impedance status) acting on the OC\_SD bit in the CONFIG register (see [Section 9.1.21](#)). The OCD flag in the STATUS register is raised anyway (see [Table 34](#), [Section 9.1.22](#)).

When the IC outputs are turned off by an OCD event, they cannot be turned on until the OCD flag is released by a GetStatus command.

---

**Attention:** The overcurrent shutdown is a critical protection feature. It is not recommended to disable it.

---

## 6.10 Undervoltage lockout (UVLO)

The L6470 provides a motor supply UVLO protection. When the motor supply voltage falls below the  $V_{StHOff}$  threshold voltage, the STATUS register UVLO flag is forced low. When a GetStatus command is sent to the IC, and the undervoltage condition has expired, the UVLO flag is released (see [Section 9.1.22](#) and [9.2.20](#)). The undervoltage condition expires when the motor supply voltage goes over the  $V_{StHOn}$  threshold voltage. When the device is in undervoltage condition, no motion command can be performed. The UVLO flag is forced low by logic reset (power-up included) even if no UVLO condition is present.

## 6.11 Thermal warning and thermal shutdown

An internal sensor allows the L6470 to detect when the device internal temperature exceeds a thermal warning or an overtemperature threshold.

When the thermal warning threshold ( $T_{j(WRN)}$ ) is reached, the TH\_WRN bit in the STATUS register is forced low (see [Section 9.1.22](#)) until the temperature decreases below  $T_{j(WRN)}$  and a GetStatus command is sent to the IC (see [Section 9.1.22](#) and [9.2.20](#)).

When the thermal shutdown threshold ( $T_{j(OFF)}$ ) is reached, the device goes into thermal shutdown condition: the TH\_SD bit in the STATUS register is forced low, the power bridges are disabled bridges in high impedance state and the HiZ bit in the STATUS register is raised (see [Section 9.1.22](#)).

The thermal shutdown condition only expires when the temperature goes below the thermal warning threshold ( $T_{j(WRN)}$ ).

On exiting thermal shutdown condition, the bridges are still disabled (HiZ flag high); any motion command makes the device exit from High Z state (HardStop and SoftStop included).

## 6.12 Reset and standby

The device can be reset and put into Standby mode through a dedicated pin. When the  $\overline{\text{STBY}}\overline{\text{RST}}$  pin is driven low, the bridges are left open (High Z state), the internal charge pump is stopped, the SPI interface and control logic are disabled and the internal 3 V voltage regulator maximum output current is reduced to  $I_{\text{REG,STBY}}$ ; as a result, the L6470 heavily reduces the power consumption. At the same time the register values are reset to default and all protection functions are disabled.  $\overline{\text{STBY}}\overline{\text{RST}}$  input must be forced low at least for  $t_{\text{STBY,min}}$  in order to ensure the complete switch to Standby mode.

On exiting Standby mode, as well as for IC power-up, a delay of up to  $t_{\text{logicwu}}$  must be given before applying a new command to allow proper oscillator and logic startup and a delay of up to  $t_{\text{cpwu}}$  must be given to allow the charge pump startup.

On exiting Standby mode, the bridges are disabled (HiZ flag high) and any motion command makes the device exit High Z state (HardStop and SoftStop included).

---

**Attention:** It is not recommended to reset the device when outputs are active. The device should be switched to high impedance state before being reset.

---

## 6.13 External switch (SW pin)

The SW input is internally pulled up to  $V_{\text{DD}}$  and detects if the pin is open or connected to ground (see [Figure 13](#)).

The SW\_F bit of the STATUS register indicates if the switch is open ('0') or closed ('1') (see [Section 9.1.22](#)); the bit value is refreshed at every system clock cycle (125 ns). The SW\_EVN flag of the STATUS register is raised when a switch turn-on event (SW input falling edge) is detected (see [Section 9.1.22](#)). A GetStatus command releases the SW\_EVN flag (see [Section 9.2.20](#)).

By default, a switch turn-on event causes a HardStop interrupt (SW\_MODE bit of CONFIG register set to '0'). Otherwise (SW\_MODE bit of CONFIG register set to '1'), switch input events do not cause interrupts and the switch status information is at the user's disposal (see [Table 34](#), [Section 9.1.22](#)).

The switch input may be used by the GoUntil and ReleaseSW commands as described in [Section 9.2.10](#) and [9.2.11](#).

If the SW input is not used, it should be connected to VDD.

Figure 13. External switch connection

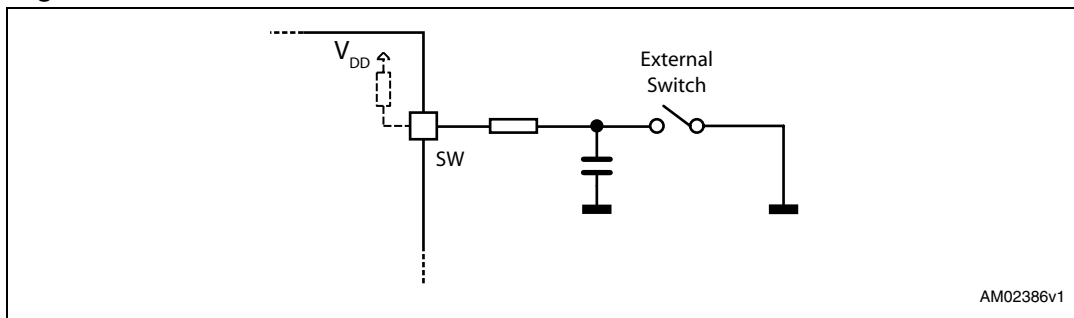

AM02386v1

## 6.14 Programmable DMOS slew rate, deadtime and blanking time

Using the POW\_SR parameter in the CONFIG register, it is possible to set the commutation speed of the power bridges output (see [Table 26](#), [Section 9.1.21](#)).

## 6.15 Integrated analog-to-digital converter

The L6470 integrates an N<sub>ADC</sub> bit ramp-compare analog-to-digital converter with a reference voltage equal to VREG. The analog-to-digital converter input is available through the ADCIN pin and the conversion result is available in the ADC\_OUT register (see [Section 9.1.16](#)).

Sampling frequency is equal to the programmed PWM frequency.

The ADC\_OUT value can be used for motor supply voltage compensation or can be at the user's disposal.

## 6.16 Internal voltage regulator

The L6470 integrates a voltage regulator which generates a 3 V voltage starting from the motor power supply (VSA and VSB). In order to make the voltage regulator stable, at least 22 μF should be connected between the VREG pin and ground (suggested value is 47 μF).

The internal voltage regulator can be used to supply the VDD pin in order to make the device digital output range 3.3 V compatible ([Figure 14](#)). A digital output range, 5 V compatible, may be obtained connecting the VDD pin to an external 5 V voltage source. In both cases, a 10 μF capacitance should be connected to the VDD pin in order to obtain a correct operation.

The internal voltage regulator is able to supply a current up to I<sub>REG,MAX</sub>, internal logic consumption included (I<sub>logic</sub>). When the device is in Standby mode, the maximum current that can be supplied is I<sub>REG,STBY</sub>, internal consumption included (I<sub>logic,STBY</sub>).

If an external 3.3 V regulated voltage is available, it can be applied to the VREG pin in order to supply all the internal logic and to avoid power dissipation of the internal 3 V voltage regulator ([Figure 14](#)). The external voltage regulator should never sink current from the VREG pin.

Figure 14. Internal 3 V linear regulator

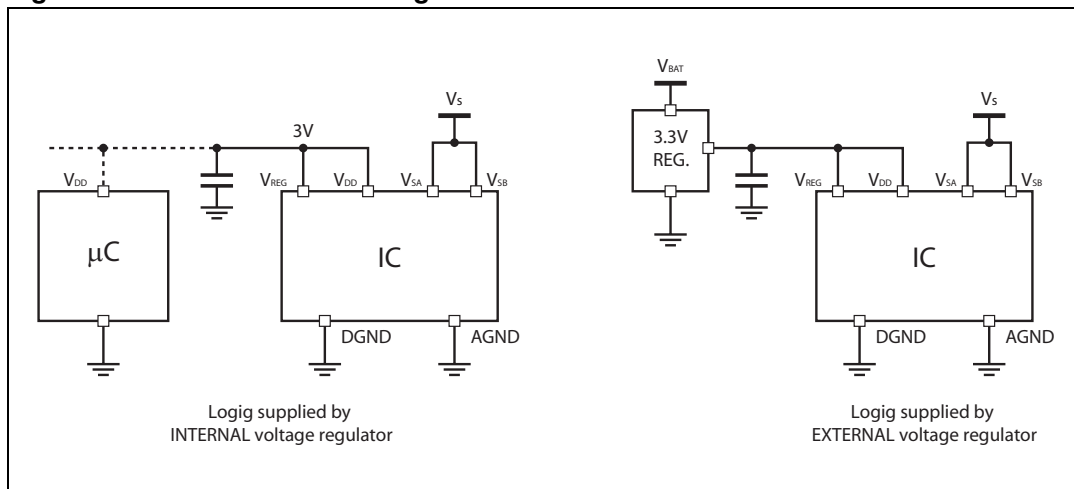

## 6.17 BUSY\SYNC pin

This pin is an open drain output which can be used as the busy flag or synchronization signal according to the SYNC\_EN bit value (STEP\_MODE register).

### 6.17.1 BUSY operation mode

The pin works as busy signal when the SYNC\_EN bit is set low (default condition). In this mode the output is forced low while a constant speed, absolute positioning or motion command is under execution. The  $\overline{\text{BUSY}}$  pin is released when the command has been executed (target speed or target position reached). The STATUS register includes a BUSY flag that is the BUSY pin mirror (see [Section 9.1.22](#)).

In the case of daisy chain configuration, BUSY pins of different ICs can be hard-wired to save host controller GPIOs.

### 6.17.2 SYNC operation mode

The pin works as synchronization signal when the SYNC\_EN bit is set high. In this mode a step-clock signal is provided on the output according to a SYNC\_SEL and STEP\_SEL parameter combination (see [Section 9.1.19](#)).

## 6.18 FLAG pin

By default, an internal open drain transistor pulls the  $\overline{\text{FLAG}}$  pin to ground when at least one of the following conditions occurs:

- Power-up or standby/reset exit
- Stall detection on A bridge
- Stall detection on B bridge
- Overcurrent detection
- Thermal warning
- Thermal shutdown
- UVLO
- Switch turn-on event
- Wrong command
- Non-performable command.

It is possible to mask one or more alarm conditions by programming the ALARM\_EN register (see [Section 9.1.20](#), [Table 21](#)). If the corresponding bit of the ALARM\_EN register is low, the alarm condition is masked and it does not cause a FLAG pin transition; all other actions imposed by alarm conditions are performed anyway. In the case of daisy chain configuration,  $\overline{\text{FLAG}}$  pins of different ICs can be or-wired to save host controller GPIOs.

## 7 Phase current control

The L6470 controls the phase current applying a sinusoidal voltage to motor windings. Phase current amplitude is not directly controlled but depends on phase voltage amplitude, load torque, motor electrical characteristics and rotation speed. Sinewave amplitude is proportional to the motor supply voltage multiplied by a coefficient ( $K_{VAL}$ ).  $K_{VAL}$  ranges from 0 to 100% and the sinewave amplitude can be obtained through the following formula:

### Equation 1

$$V_{OUT} = V_S \cdot K_{VAL}$$

Different  $K_{VAL}$  values can be programmed for acceleration, deceleration and constant speed phases and when the motor is stopped (HOLD phase) through the  $KVAL\_ACC$ ,  $KVAL\_DEC$ ,  $KVAL\_RUN$  and  $KVAL\_HOLD$  registers (see [Section 9.1.10](#)).  $KVAL$  value is calculated according to the following formula:

### Equation 2

$$K_{VAL} = [(K_{VAL\_X} + BEMF\_COMP) \times VSCOMP \times K\_THERM] \times \text{microstep}$$

where  $K_{VAL\_X}$  is the starting  $K_{VAL}$  value programmed for present motion phase ( $KVAL\_ACC$ ,  $KVAL\_DEC$ ,  $KVAL\_RUN$  or  $KVAL\_HOLD$ ),  $BEMF\_COMP$  is the BEMF compensation curve value,  $VSCOMP$  and  $K\_THERM$  are the motor supply voltage and winding resistance compensation factors and microstep is the current microstep value (fraction of target peak current).

The L6470 offers various methods to guarantee a stable current value, allowing the compensation of:

- low speed optimization ([Section 7.3 7.3](#))
- back electromotive force value ([Section 7.4 7.4](#))
- motor supply voltage variation ([Section 7.5 7.5](#))
- windings resistance variation ([Section 7.67.6](#)).

### 7.1 PWM sinewave generators

The two voltage sinewaves applied to the stepper motor phases are generated by two PWM modulators.

The PWM frequency ( $f_{PWM}$ ) is proportional to the oscillator frequency ( $f_{OSC}$ ) and can be obtained through the following formula:

### Equation 3

$$f_{PWM} = \frac{f_{OSC}}{512 \cdot N} \cdot m$$

'N' is the integer division factor and 'm' is the multiplication factor. 'N' and 'm' values can be programmed by the  $F\_PWM\_INT$  and  $F\_PWM\_DEC$  parameters in the CONFIG register (see [Table 28](#) and [Table 29](#), [Section 9.1.21](#)).

Available PWM frequencies are listed in [Section 9.1.21](#) from [Table 30](#) to [Table 33](#).

## 7.2 Sensorless stall detection

Depending on motor speed and load angle characteristics, the L6470 offers a motor stall condition detection using a programmable current comparator.

When a stall event occurs, the respective flag (STEP\_LOSS\_A or STEP\_LOSS\_B) is forced low until a GetStatus command or a system reset occurs (see [Section 9.2.20](#)).

## 7.3 Low speed optimization

When the motor is driven at a very low speed using a small driving voltage, the resulting phase current can be distorted. As a consequence, the motor position is different from the ideal one (see [Figure 15](#)).

The L6470 implements a low speed optimization in order to remove this effect.

**Figure 15. Current distortion and compensation**

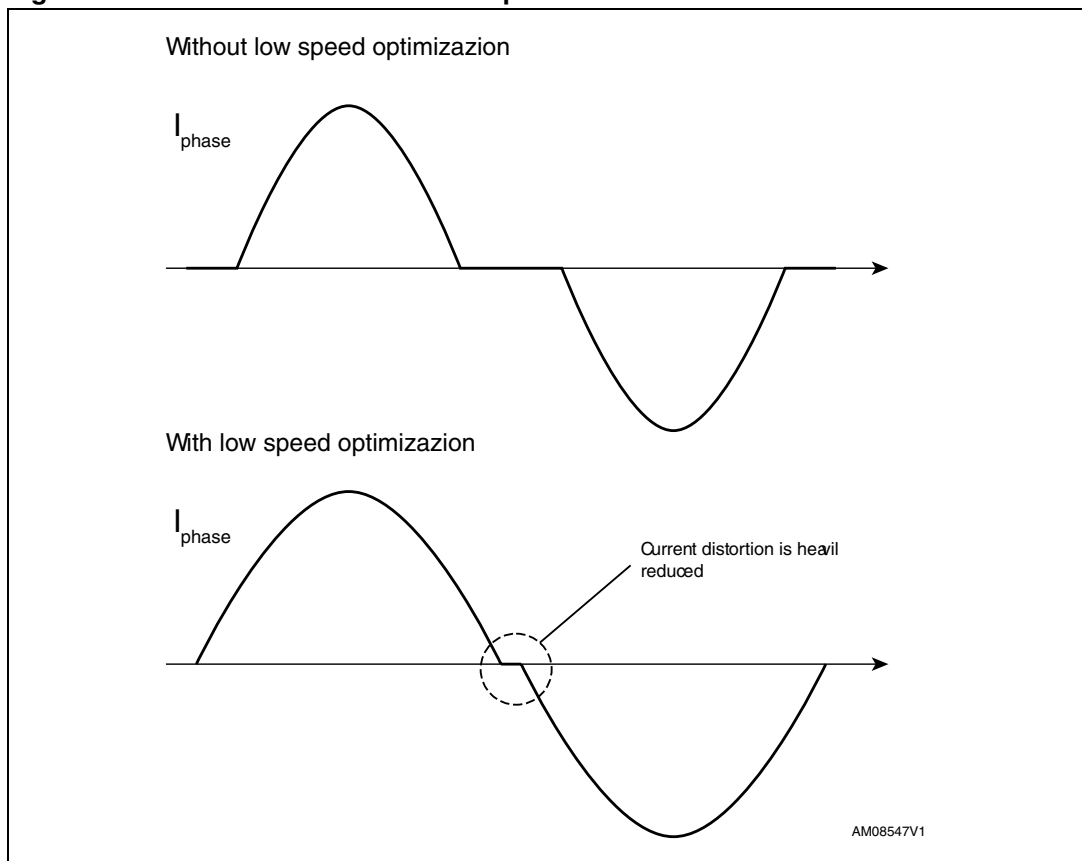

The optimization can be enabled setting high the LSPD\_OPT bit in the MIN\_SPEED register (see [Section 9.1.8](#)) and is active in a speed range from zero to MIN\_SPEED. When low speed optimization is enabled, speed profile minimum speed is forced to zero.

## 7.4 BEMF compensation

Using the speed information, a compensation curve is added to the amplitude of the voltage waveform applied to the motor winding in order to compensate the BEMF variations during acceleration and deceleration (see [Figure 16](#)).

The compensation curve is approximated by a stacked line with a starting slope (ST\_SLP) when speed is lower than a programmable threshold speed (INT\_SPEED) and a fine slope (FN\_SLP\_ACC and FN\_SLP\_DEC) when speed is greater than the threshold speed (see [Section 9.1.11](#), [Section 9.1.12](#), [Section 9.1.13](#) and [Section 9.1.14](#)).

**Figure 16. BEMF compensation curve**

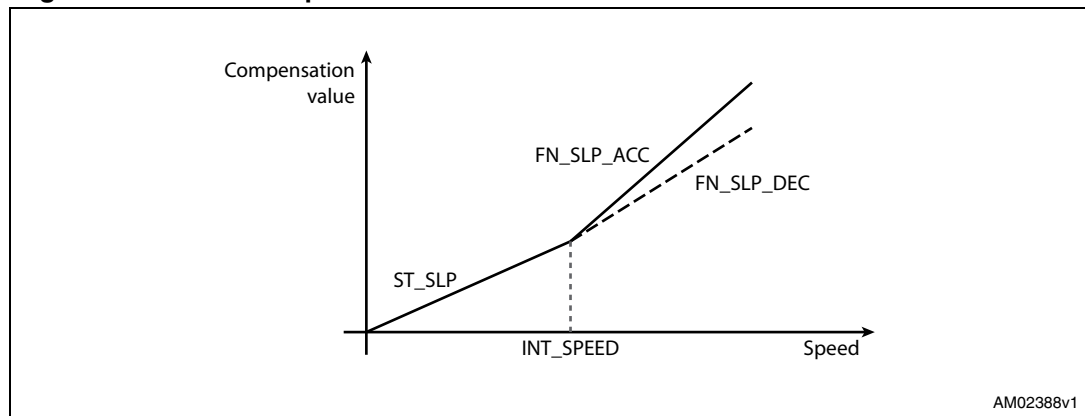

To obtain different current values during acceleration and deceleration phases, two different final slope values, and consequently two different compensation curves, can be programmed.

The acceleration compensation curve is applied when the motor runs. No BEMF compensation is applied when the motor is stopped.

## 7.5 Motor supply voltage compensation

The sinewave amplitude generated by the PWM modulators is directly proportional to the motor supply voltage ( $V_S$ ). When the motor supply voltage is different from its nominal value, the motor phases are driven with an incorrect voltage. The L6470 can compensate motor supply voltage variations in order to avoid this effect.

The motor supply voltage should be connected to the integrated ADC input through a resistor divider in order to obtain  $V_{REG}/2$  voltage at the ADCIN pin when  $V_S$  is at its nominal value (see [Figure 17](#)).

The ADC input is sampled at  $f_S$  frequency, which is equal to PWM frequency.

Figure 17. Motor supply voltage compensation circuit

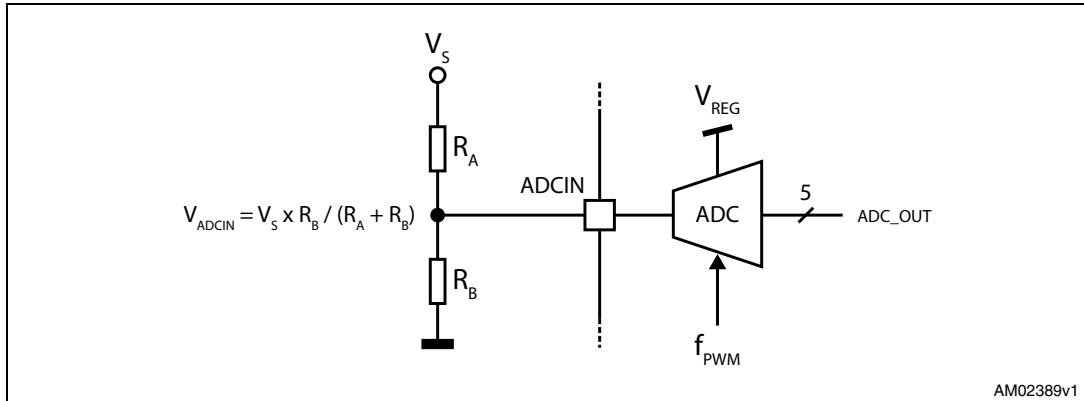

Motor supply voltage compensation can be enabled setting high the EN\_VSCOMP bit of the CONFIG register (see [Table 22](#), [Section 9.1.21](#)). If the EN\_VSCOMP bit is low, the compensation is disabled and the internal analog-to-digital converter is at the user's disposal; sampling rate is always equal to PWM frequency.

## 7.6 Winding resistance thermal drift compensation

The higher the winding resistance, the greater the voltage to be applied in order to obtain the same phase current.

The L6470 integrates a register (K\_THERM) which can be used to compensate phase resistance increment due to temperature rising.

The value in the K\_THERM register (see [Section 9.1.15](#)) multiplies the duty cycle value allowing a higher phase resistance value to be faced.

The compensation algorithm and the eventual motor temperature measurement should be implemented by microcontroller firmware.

## 8 Serial interface

The integrated 8-bit serial peripheral interface (SPI) is used for a synchronous serial communication between the host microprocessor (always master) and the L6470 (always slave).

The SPI uses chip select ( $\overline{CS}$ ), serial clock (CK), serial data input (SDI) and serial data output (SDO) pins. When  $\overline{CS}$  is high, the device is unselected and the SDO line is inactive (high-impedance).

The communication starts when  $\overline{CS}$  is forced low. The CK line is used for synchronization of data communication.

All commands and data bytes are shifted into the device through the SDI input, most significant bit first. The SDI is sampled on the rising edges of the CK.

All output data bytes are shifted out of the device through the SDO output, most significant bit first. The SDO is latched on the falling edges of the CK. When a return value from the device is not available, an all zero byte is sent.

After each byte transmission the  $\overline{CS}$  input must be raised and be kept high for at least  $t_{disCS}$  in order to allow the device to decode the received command and put the return value into the SHIFT register.

All timing requirements are shown in *Figure 18* (see *Section 3: Electrical characteristics* for values).

Multiple devices can be connected in daisy chain configuration, as shown in *Figure 19*.

**Figure 18. SPI timings diagram**

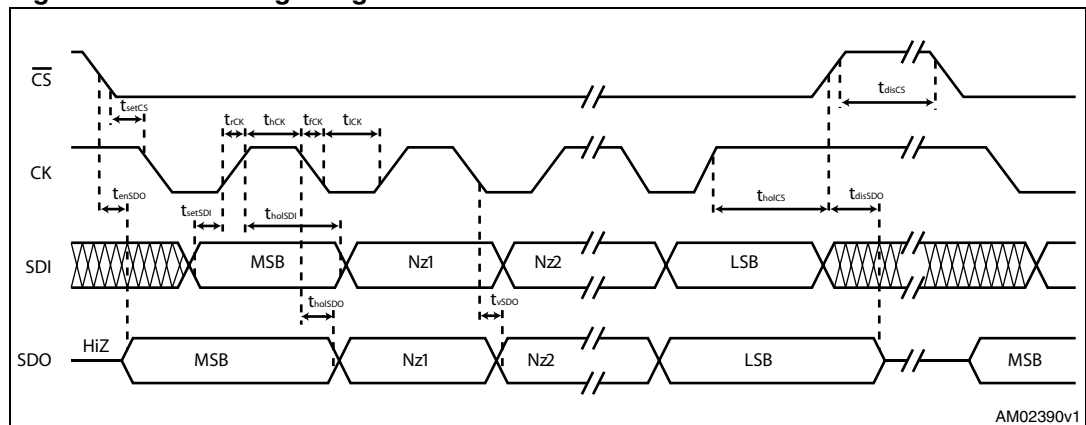
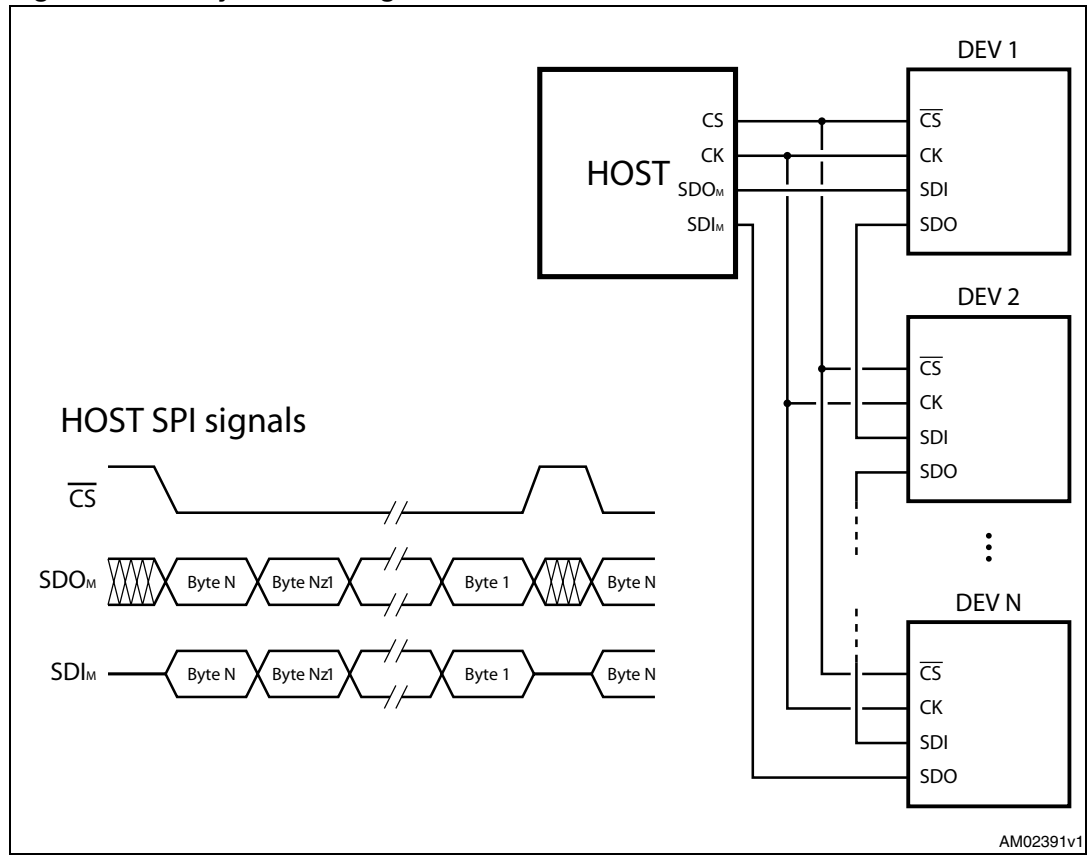

Figure 19. Daisy chain configuration



## 9 Programming manual

### 9.1 Registers and flags description

The following is a map of the user registers available (detailed description in respective paragraphs):

**Table 9. Registers map**

Address [Hex]	Register name	Register function	Len. [bit]	Reset Hex	Reset value	Remarks <sup>(1)</sup>
h01	ABS_POS	Current position	22	000000	0	R, WS
h02	EL_POS	Electrical position	9	000	0	R, WS
h03	MARK	Mark position	22	000000	0	R, WR
h04	SPEED	Current speed	20	00000	0 step/tick (0 step/s)	R
h05	ACC	Acceleration	12	08A	125.5e-12 step/tick <sup>2</sup> (2008 step/s <sup>2</sup> )	R, WS
h06	DEC	Deceleration	12	08A	125.5e-12 step/tick <sup>2</sup> (2008 step/s <sup>2</sup> )	R, WS
h07	MAX_SPEED	Maximum speed	10	041	248e-6 step/tick (991.8 step/s)	R, WR
h08	MIN_SPEED	Minimum speed	13	000	0 step/tick (0 step/s)	R, WS
h15	FS_SPD	Full-step speed	10	027	150.7e-6 step/tick (602.7 step/s)	R, WR
h09	KVAL_HOLD	Holding K <sub>VAL</sub>	8	29	0.16-VS	R, WR
h0A	KVAL_RUN	Constant speed K <sub>VAL</sub>	8	29	0.16-VS	R, WR
h0B	KVAL_ACC	Acceleration starting K <sub>VAL</sub>	8	29	0.16-VS	R, WR
h0C	KVAL_DEC	Deceleration starting K <sub>VAL</sub>	8	29	0.16-VS	R, WR
h0D	INT_SPEED	Intersect speed	14	0408	15.4e-6 step/tick (61.5 step/s)	R, WH
h0E	ST_SLP	Start slope	8	19	0.038% s/step	R, WH
h0F	FN_SLP_ACC	Acceleration final slope	8	29	0.063% s/step	R, WH
h10	FN_SLP_DEC	Deceleration final slope	8	29	0.063% s/step	R, WH
h11	K_THERM	Thermal compensation factor	4	0	1.0	R, WR
h12	ADC_OUT	ADC output	5	XX <sup>(2)</sup>		R
h13	OCD_TH	OCD threshold	4	8	3.38A	R, WR
h14	STALL_TH	STALL threshold	7	40	2.03A	R, WR
h16	STEP_MODE	Step mode	8	7	128 microsteps	R, WH
h17	ALARM_EN	Alarm enable	8	FF	All alarms enabled	R, WS

Table 9. Registers map (continued)

Address [Hex]	Register name	Register function	Len. [bit]	Reset Hex	Reset value	Remarks <sup>(1)</sup>
h18	CONFIG	IC configuration	16	2E88	Internal oscillator, 2 MHz OSCOUT clock, supply voltage compensation disabled, overcurrent shutdown enabled, slew rate = 290 V/μs PWM frequency = 15.6 kHz.	R, WH
h19	STATUS	Status	16	XXXX <sup>(2)</sup>	High impedance state, UVLO/Reset flag set.	R
h1A	RESERVED	Reserved address				
h1B	RESERVED	Reserved address				

1. R: readable, WH: writable only when outputs are in high impedance, WS: writable only when motor is stopped, WR: always writable.
2. According to startup conditions.

### 9.1.1 ABS\_POS

The ABS\_POS register contains the current motor absolute position in agreement with the selected step mode; the stored value unit is equal to the selected step mode (full, half, quarter, etc.). The value is in 2's complement format and it ranges from  $-2^{21}$  to  $+2^{21}-1$ .

At power-on the register is initialized to "0" (HOME position).

Any attempt to write the register when the motor is running causes the command to be ignored and the NOTPERF\_CMD flag to rise (see [Section 9.1.22](#)).

### 9.1.2 EL\_POS

The EL\_POS register contains the current electrical position of the motor. The two MSbits indicate the current step and the other bits indicate the current microstep (expressed in step/128) within the step.

Table 10. EL\_POS register

Bit 8	Bit 7	Bit 6	Bit 5	Bit 4	Bit 3	Bit 2	Bit 1	Bit 0
STEP		MICROSTEP						

When the EL\_POS register is written by the user, the new electrical position is instantly imposed. When the EL\_POS register is written, its value must be masked in order to match with the step mode selected in the STEP\_MODE register in order to avoid a wrong microstep value generation (see [Section 9.1.19](#)); otherwise the resulting microstep sequence is incorrect.

Any attempt to write the register when the motor is running causes the command to be ignored and the NOTPERF\_CMD flag to rise (see [Section 9.1.22](#)).

### 9.1.3 MARK

The MARK register contains an absolute position called MARK according to the selected step mode; the stored value unit is equal to the selected step mode (full, half, quarter, etc.). It is in 2's complement format and it ranges from  $-2^{21}$  to  $+2^{21}-1$ .

### 9.1.4 SPEED

The SPEED register contains the current motor speed, expressed in step/tick (format unsigned fixed point 0.28).

In order to convert the SPEED value in step/s, the following formula can be used:

#### Equation 4

$$[\text{step/s}] = \frac{\text{SPEED} \cdot 2^{-28}}{\text{tick}}$$

where SPEED is the integer number stored in the register and tick is 250 ns.

The available range is from 0 to 15625 step/s with a resolution of 0.015 step/s.

*Note:* The range effectively available to the user is limited by the MAX\_SPEED parameter.

Any attempt to write the register causes the command to be ignored and the NOTPERF\_CMD flag to rise (see [Section 9.1.22](#)).

### 9.1.5 ACC

The ACC register contains the speed profile acceleration expressed in step/tick<sup>2</sup> (format unsigned fixed point 0.40).

In order to convert ACC value in step/s<sup>2</sup>, the following formula can be used:

#### Equation 5

$$[\text{step/s}^2] = \frac{\text{ACC} \cdot 2^{-40}}{\text{tick}^2}$$

where ACC is the integer number stored in the register and tick is 250 ns.

The available range is from 14.55 to 59590 step/s<sup>2</sup> with a resolution of 14.55 step/s<sup>2</sup>.

When the ACC value is set to 0xFFFF, the device works in infinite acceleration mode.

Any attempt to write to the register when the motor is running causes the command to be ignored and the NOTPERF\_CMD flag to rise (see [Section 9.1.22](#)).

### 9.1.6 DEC

The DEC register contains the speed profile deceleration expressed in step/tick<sup>2</sup> (format unsigned fixed point 0.40).

In order to convert DEC value in step/s<sup>2</sup>, the following formula can be used:

#### Equation 6

$$[\text{step/s}^2] = \frac{\text{DEC} \cdot 2^{-40}}{\text{tick}^2}$$

where DEC is the integer number stored in the register and tick is 250 ns.

The available range is from 14.55 to 59590 step/s<sup>2</sup> with a resolution of 14.55 step/s<sup>2</sup>.

When the device is working in infinite acceleration mode, this value is ignored.

Any attempt to write the register when the motor is running causes the command to be ignored and the NOTPERF\_CMD flag to rise (see [Section 9.1.22](#)).

### 9.1.7 MAX\_SPEED

The MAX\_SPEED register contains the speed profile maximum speed expressed in step/tick (format unsigned fixed point 0.18).

In order to convert it in step/s, the following formula can be used:

#### Equation 7

$$[\text{step/s}] = \frac{\text{MAX\_SPEED} \cdot 2^{-18}}{\text{tick}}$$

where MAX\_SPEED is the integer number stored in the register and tick is 250 ns.

The available range is from 15.25 to 15610 step/s with a resolution of 15.25 step/s.

### 9.1.8 MIN\_SPEED

The MIN\_SPEED register contains the following parameters:

**Table 11. MIN\_SPEED register**

Bit 12	Bit 11	Bit 10	Bit 9	Bit 8	Bit 7	Bit 6	Bit 5	Bit 4	Bit 3	Bit 2	Bit 1	Bit 0
LSPD_OPT	MIN_SPEED											

The MIN\_SPEED parameter contains the speed profile minimum speed. Its value is expressed in step/tick and to convert it in step/s, the following formula can be used:

#### Equation 8

$$[\text{step/s}] = \frac{\text{MIN\_SPEED} \cdot 2^{-24}}{\text{tick}}$$

where MIN\_SPEED is the integer number stored in the register and tick is the ramp 250 ns.

The available range is from 0 to 976.3 step/s with a resolution of 0.238 step/s.

When the LSPD\_OPT bit is set high, the low speed optimization feature is enabled and the MIN\_SPEED value indicates the speed threshold below which the compensation works. In this case the minimum speed of the speed profile is set to zero.

An attempt to write the register when the motor is running causes the NOTPERF\_CMD flag to rise.

### 9.1.9 FS\_SPD

The FS\_SPD register contains the threshold speed. When the actual speed exceeds this value, the step mode is automatically switched to full-step two-phase on. Its value is

expressed in step/tick (format unsigned fixed point 0.18) and to convert it in step/s, the following formula can be used.

**Equation 9**

$$[\text{step/s}] = \frac{(\text{FS\_SPD} + 0.5) \cdot 2^{-18}}{\text{tick}}$$

If the FS\_SPD value is set to hFF (max.) the system always works in microstepping mode (SPEED must go beyond the threshold to switch to Full-step mode). Setting FS\_SPD to zero does not have the same effect as setting Step mode to full-step two-phase on: the zero FS\_SPD value is equivalent to a speed threshold of about 7.63 step/s.

The available range is from 7.63 to 15625 step/s with a resolution of 15.25 step/s.

**9.1.10 KVAL\_HOLD, KVAL\_RUN, KVAL\_ACC and KVAL\_DEC**

The KVAL\_HOLD register contains the  $K_{VAL}$  value that is assigned to the PWM modulators when the motor is stopped (compensation excluded).

The KVAL\_RUN register contains the  $K_{VAL}$  value that is assigned to the PWM modulators when the motor is running at constant speed (compensation excluded).

The KVAL\_ACC register contains the starting  $K_{VAL}$  value that can be assigned to the PWM modulators during acceleration (compensation excluded).

The KVAL\_DEC register contains the starting  $K_{VAL}$  value that can be assigned to the PWM modulators during deceleration (compensation excluded).

The available range is from 0 to  $0.996 \times V_S$  with a resolution of  $0.004 \times V_S$ , as shown in [Table 12](#).

**Table 12. Voltage amplitude regulation registers**

KVAL_X [7..0]								Output voltage
0	0	0	0	0	0	0	0	0
0	0	0	0	0	0	0	1	$V_S \times (1/256)$
⋮	⋮	⋮	⋮	⋮	⋮	⋮	⋮	⋮
1	1	1	1	1	1	1	0	$V_S \times (254/256)$
1	1	1	1	1	1	1	1	$V_S \times (255/256)$

**9.1.11 INT\_SPEED**

The INT\_SPEED register contains the speed value at which the BEMF compensation curve changes slope (see [Section 7.4](#)). Its value is expressed in step/tick and to convert it in step/s, the following formula can be used:

**Equation 10**

$$[\text{step/s}] = \frac{\text{INT\_SPEED} \cdot 2^{-26}}{\text{tick}}$$

where INT\_SPEED is the integer number stored in the register and tick is 250 ns.



The available range is from 0 to 976.5 step/s with a resolution of 0.0596 step/s.

Any attempt to write the register when the motor is running causes the command to be ignored and the NOTPERF\_CMD flag to rise (see [Section 9.1.22](#)).

### 9.1.12 ST\_SLP

The ST\_SLP register contains the BEMF compensation curve slope that is used when the speed is lower than the intersect speed (see [Section 7.4](#)). Its value is expressed in s/step and the available range is from 0 to 0.004 with a resolution of 0.000015.

When ST\_SLP, FN\_SLP\_ACC and FN\_SLP\_DEC parameters are set to zero, no BEMF compensation is performed.

Any attempt to write the register when the motor is running causes the command to be ignored and the NOTPERF\_CMD flag to rise (see [Section 9.1.22](#)).

### 9.1.13 FN\_SLP\_ACC

The FN\_SLP\_ACC register contains the BEMF compensation curve slope that is used when the speed is greater than the intersect speed during acceleration (see [Section 7.47.4](#)). Its value is expressed in s/step and the available range is from 0 to 0.004 with a resolution of 0.000015.

When ST\_SLP, FN\_SLP\_ACC and FN\_SLP\_DEC parameters are set to zero, no BEMF compensation is performed.

Any attempt to write the register when the motor is running causes the command to be ignored and the NOTPERF\_CMD flag to rise (see [Section 9.1.22](#)).

### 9.1.14 FN\_SLP\_DEC

The FN\_SLP\_DEC register contains the BEMF compensation curve slope that is used when the speed is greater than the intersect speed during deceleration (see [Section 7.47.4](#)). Its value is expressed in s/step and the available range is from 0 to 0.004 with a resolution of 0.000015.

When ST\_SLP, FN\_SLP\_ACC and FN\_SLP\_DEC parameters are set to zero, no BEMF compensation is performed.

Any attempt to write the register when the motor is running causes the command to be ignored and the NOTPERF\_CMD flag to rise (see [Section 9.1.22](#)).

### 9.1.15 K\_THERM

The K\_THERM register contains the value used by the winding resistance thermal drift compensation system (see [Section 7.6](#)).

The available range is from 1 to 1.46875 with a resolution of 0.03125, as shown in [Table 13](#).

**Table 13. Winding resistance thermal drift compensation coefficient**

K_THERM [3..0]				Compensation coeff.
0	0	0	0	1
0	0	0	1	1.03125
⋮	⋮	⋮	⋮	⋮

**Table 13. Winding resistance thermal drift compensation coefficient (continued)**

K_THERM [3..0]				Compensation coeff.
1	1	1	0	1.4375
1	1	1	1	1.46875

### 9.1.16 ADC\_OUT

The ADC\_OUT register contains the result of the analog-to-digital conversion of the ADCIN pin voltage; the result is available even if the supply voltage compensation is disabled.

Any attempt to write to the register causes the command to be ignored and the NOTPERF\_CMD flag to rise (see [Section 9.1.22](#)).

**Table 14. ADC\_OUT value and motor supply voltage compensation feature**

V <sub>S</sub>	V <sub>ADCIN</sub> /V <sub>REG</sub>	ADC_OUT [4..0]					Compensation coefficient
Greater than V <sub>S,nom</sub> + 50%	> 24/32	1	1	X	X	X	0.65625
V <sub>S,nom</sub> + 50%	24/32	1	1	0	0	0	0.65625
⋮	⋮	⋮	⋮	⋮	⋮	⋮	⋮
V <sub>S,nom</sub>	16/32	1	0	0	0	0	1
⋮	⋮	⋮	⋮	⋮	⋮	⋮	⋮
V <sub>S,nom</sub> - 50%	8/32	0	1	0	0	0	1.968875
Lower than V <sub>S,nom</sub> - 50%	< 8/32	0	0	X	X	X	1.968875

### 9.1.17 OCD\_TH

The OCD\_TH register contains the overcurrent threshold value (see [Section 6.9](#)). The available range is from 375 mA to 6 A, in steps of 375 mA, as shown in [Table 15](#).

**Table 15. Overcurrent detection threshold**

OCD_TH [3..0]				Overcurrent detection threshold
0	0	0	0	375 mA
0	0	0	1	750 mA
...	...	...	...	...
1	1	1	0	5.625 A
1	1	1	1	6 A

### 9.1.18 STALL\_TH

The STALL\_TH register contains the stall detection threshold value (see [Section 7.2](#)). The available range is from 31.25 mA to 4 A with a resolution of 31.25 mA.

**Table 16. Stall detection threshold**

STALL_th [6..0]							Stall detection threshold
0	0	0	0	0	0	0	31.25 mA
0	0	0	0	0	0	1	62.5 mA
...	...	...	...	...	...	...	...
1	1	1	1	1	1	0	3.969 A
1	1	1	1	1	1	1	4 A

### 9.1.19 STEP\_MODE

The STEP\_MODE register has the following structure:

**Table 17. STEP\_MODE register**

Bit 7	Bit 6	Bit 5	Bit 4	Bit 3	Bit 2	Bit 1	Bit 0
SYNC_EN	SYNC_SEL			0 <sup>(1)</sup>	STEP_SEL		

1. When the register is written, this bit should be set to 0.

The STEP\_SEL parameter selects one of eight possible stepping modes:

**Table 18. Step mode selection**

STEP_SEL[2..0]			Step mode
0	0	0	Full-step
0	0	1	Half-step
0	1	0	1/4 microstep
0	1	1	1/8 microstep
1	0	0	1/16 microstep
1	0	1	1/32 microstep
1	1	0	1/64 microstep
1	1	1	1/128 microstep

Every time the step mode is changed, the electrical position (i.e. the point of microstepping sinewave that is generated) is reset to the first microstep.

---

**Warning:** Every time STEP\_SEL is changed, the value in the ABS\_POS register loses meaning and should be reset.

---

Any attempt to write the register when the motor is running causes the command to be ignored and the NOTPERF\_CMD flag to rise (see [Section 9.1.22](#)).

When the SYNC\_EN bit is set low,  $\overline{\text{BUSY}}/\text{SYNC}$  output is forced low during command execution, otherwise, when the SYNC\_EN bit is set high,  $\overline{\text{BUSY}}/\text{SYNC}$  output provides a clock signal according to the SYNC\_SEL parameter.

**Table 19. SYNC output frequency**

		STEP_SEL ( $f_{FS}$ is the full-step frequency)							
		000	001	010	011	100	101	110	111
SYNC_SEL	000	$f_{FS}/2$	$f_{FS}/2$	$f_{FS}/2$	$f_{FS}/2$	$f_{FS}/2$	$f_{FS}/2$	$f_{FS}/2$	$f_{FS}/2$
	001	NA	$f_{FS}$	$f_{FS}$	$f_{FS}$	$f_{FS}$	$f_{FS}$	$f_{FS}$	$f_{FS}$
	010	NA	NA	$2 \cdot f_{FS}$	$2 \cdot f_{FS}$	$2 \cdot f_{FS}$	$2 \cdot f_{FS}$	$2 \cdot f_{FS}$	$2 \cdot f_{FS}$
	011	NA	NA	NA	$4 \cdot f_{FS}$	$4 \cdot f_{FS}$	$4 \cdot f_{FS}$	$4 \cdot f_{FS}$	$4 \cdot f_{FS}$
	100	NA	NA	NA	NA	$8 \cdot f_{FS}$	$8 \cdot f_{FS}$	$8 \cdot f_{FS}$	$8 \cdot f_{FS}$
	101	NA	NA	NA	NA	NA	$16 \cdot f_{FS}$	$16 \cdot f_{FS}$	$16 \cdot f_{FS}$
	110	NA	NA	NA	NA	NA	NA	$32 \cdot f_{FS}$	$32 \cdot f_{FS}$
	111	NA	NA	NA	NA	NA	NA	NA	$64 \cdot f_{FS}$

The synchronization signal is obtained starting from electrical position information (EL\_POS register) according to [Table 10](#):

**Table 20. SYNC signal source**

SYNC_SEL[2..0]			Source
0	0	0	EL_POS[7]
0	0	1	EL_POS[6]
0	1	0	EL_POS[5]
0	1	1	EL_POS[4]
1	0	0	EL_POS[3]
1	0	1	EL_POS[2]
1	1	0	EL_POS[1]
1	1	1	EL_POS[0]

### 9.1.20 ALARM\_EN

The ALARM\_EN register allows the selection of which alarm signals are used to generate the FLAG output. If the respective bit of the ALARM\_EN register is set high, the alarm condition forces the FLAG pin output down.

**Table 21. ALARM\_EN register**

ALARM_EN bit	Alarm condition
0 (LSB)	Overcurrent
1	Thermal shutdown
2	Thermal warning
3	Undervoltage
4	Stall detection (Bridge A)
5	Stall detection (Bridge B)
6	Switch turn-on event
7 (MSB)	Wrong or non-performable command

### 9.1.21 CONFIG

The CONFIG register has the following structure:

**Table 22. CONFIG register**

Bit 15	Bit 14	Bit 13	Bit 12	Bit 11	Bit 10	Bit 9	Bit 8
F_PWM_INT				F_PWM_DEC			POW_SR
Bit 7	Bit 6	Bit 5	Bit 4	Bit 3	Bit 2	Bit 1	Bit 0
OC_SD	RESERVED	EN_VSCOMP	SW_MODE	EXT_CLK	OSC_SEL		

The OSC\_SEL and EXT\_CLK bits set the system clock source:

**Table 23. Oscillator management**

EXT_C LK	OSC_SEL[2..0]			Clock source	OSCIN	OSCOU T
0	0	0	0	Internal oscillator: 16 MHz	Unused	Unused
0	0	0	1			
0	0	1	0			
0	0	1	1			
1	0	0	0	Internal oscillator: 16 MHz	Unused	Supplies a 2-MHz clock
1	0	0	1	Internal oscillator: 16 MHz	Unused	Supplies a 4-MHz clock
1	0	1	0	Internal oscillator: 16 MHz	Unused	Supplies an 8-MHz clock
1	0	1	1	Internal oscillator: 16 MHz	Unused	Supplies a 16-MHz clock

**Table 23. Oscillator management (continued)**

EXT_C LK	OSC_SEL[2..0]			Clock source	OSCIN	OSCOUT
0	1	0	0	External crystal or resonator: 8 MHz	Crystal/resonator driving	Crystal/resonator driving
0	1	0	1	External crystal or resonator: 16 MHz	Crystal/resonator driving	Crystal/resonator driving
0	1	1	0	External crystal or resonator: 24 MHz	Crystal/resonator driving	Crystal/resonator driving
0	1	1	1	External crystal or resonator: 32 MHz	Crystal/resonator driving	Crystal/resonator driving
1	1	0	0	Ext clock source: 8 MHz (Crystal/resonator driver disabled)	Clock source	Supplies inverted OSCIN signal
1	1	0	1	Ext clock source: 16 MHz (Crystal/resonator driver disabled)	Clock source	Supplies inverted OSCIN signal
1	1	1	0	Ext clock source: 24 MHz (Crystal/resonator driver disabled)	Clock source	Supplies inverted OSCIN signal
1	1	1	1	Ext clock source: 32 MHz (Crystal/resonator driver disabled)	Clock source	Supplies inverted OSCIN signal

The SW\_MODE bit sets the external switch to act as HardStop interrupt or not:

**Table 24. External switch hard stop interrupt mode**

SW_MODE	Switch mode
0	HardStop interrupt
1	User disposal

The OC\_SD bit sets whether an overcurrent event causes or not the bridges to turn off; the OCD flag in the STATUS register is forced low anyway:

**Table 25. Overcurrent event**

OC_SD	Overcurrent event
1	Bridges shut down
0	Bridges do not shut down

The POW\_SR bits set the slew rate value of power bridge output:

**Table 26. Programmable power bridge output slew rate values**

POW_SR [1..0]		Output slew rate <sup>(1)</sup> [V/μs]
0	0	180
0	1	180
1	0	290
1	1	530

1. See  $S_{Rout_r}$  and  $S_{Rout_f}$  parameters in [Table 5](#) for details.

The EN\_VSCOMP bit sets whether the motor supply voltage compensation is enabled or not.

**Table 27. Motor supply voltage compensation enable**

EN_VSCOMP	Motor supply voltage compensation
0	Disabled
1	Enabled

The F\_PWM\_INT bits set the integer division factor of PWM frequency generation.

**Table 28. PWM frequency: integer division factor**

F_PWM_INT [2..0]			Integer division factor
0	0	0	1
0	0	1	2
0	1	0	3
0	1	1	4
1	0	0	5
1	0	1	6
1	1	0	7
1	1	1	

The F\_PWM\_DEC bits set the multiplication factor of PWM frequency generation.

**Table 29. PWM frequency: multiplication factor**

F_PWM_DEC [2..0]			Multiplication factor
0	0	0	0.625
0	0	1	0.75
0	1	0	0.875
0	1	1	1
1	0	0	1.25
1	0	1	1.5
1	1	0	1.75
1	1	1	2

In the following tables all available PWM frequencies are listed according to oscillator frequency, F\_PWM\_INT and F\_PWM\_DEC values (CONFIG register OSC\_SEL parameter must be correctly programmed).

**Table 30. Available PWM frequencies [kHz]: 8-MHz oscillator frequency**

F_PWM_INT	F_PWM_DEC							
	000	001	010	011	100	101	110	111
000	9.8	11.7	13.7	15.6	19.5	23.4	27.3	31.3
001	4.9	5.9	6.8	7.8	9.8	11.7	13.7	15.6
010	3.3	3.9	4.6	5.2	6.5	7.8	9.1	10.4
011	2.4	2.9	3.4	3.9	4.9	5.9	6.8	7.8
100	2.0	2.3	2.7	3.1	3.9	4.7	5.5	6.3
101	1.6	2.0	2.3	2.6	3.3	3.9	4.6	5.2
110	1.4	1.7	2.0	2.2	2.8	3.3	3.9	4.5

**Table 31. Available PWM frequencies [kHz]: 16-MHz oscillator frequency**

F_PWM_INT	F_PWM_DEC							
	000	001	010	011	100	101	110	111
000	19.5	23.4	27.3	31.3	39.1	46.9	54.7	62.5
001	9.8	11.7	13.7	15.6	19.5	23.4	27.3	31.3
010	6.5	7.8	9.1	10.4	13.0	15.6	18.2	20.8

**Table 31. Available PWM frequencies [kHz]: 16-MHz oscillator frequency**

F_PWM_INT	F_PWM_DEC							
	000	001	010	011	100	101	110	111
011	4.9	5.9	6.8	7.8	9.8	11.7	13.7	15.6
100	3.9	4.7	5.5	6.3	7.8	9.4	10.9	12.5
101	3.3	3.9	4.6	5.2	6.5	7.8	9.1	10.4
110	2.8	3.3	3.9	4.5	5.6	6.7	7.8	8.9

**Table 32. Available PWM frequencies [kHz]: 24-MHz oscillator frequency**

F_PWM_INT	F_PWM_DEC							
	000	001	010	011	100	101	110	111
000	29.3	35.2	41.0	46.9	58.6	70.3	82.0	93.8
001	14.6	17.6	20.5	23.4	29.3	35.2	41.0	46.9
010	9.8	11.7	13.7	15.6	19.5	23.4	27.3	31.3
011	7.3	8.8	10.3	11.7	14.6	17.6	20.5	23.4
100	5.9	7.0	8.2	9.4	11.7	14.1	16.4	18.8
101	4.9	5.9	6.8	7.8	9.8	11.7	13.7	15.6
110	4.2	5.0	5.9	6.7	8.4	10.0	11.7	13.4

**Table 33. Available PWM frequencies [kHz]: 32-MHz oscillator frequency**

F_PWM_INT	F_PWM_DEC							
	000	001	010	011	100	101	110	111
000	39.1	46.9	54.7	62.5	78.1	93.8	109.4	125.0
001	19.5	23.4	27.3	31.3	39.1	46.9	54.7	62.5
010	13.0	15.6	18.2	20.8	26.0	31.3	36.5	41.7
011	9.8	11.7	13.7	15.6	19.5	23.4	27.3	31.3
100	7.8	9.4	10.9	12.5	15.6	18.8	21.9	25.0
101	6.5	7.8	9.1	10.4	13.0	15.6	18.2	20.8
110	5.6	6.7	7.8	8.9	11.2	13.4	15.6	17.9

Any attempt to write the CONFIG register when the motor is running causes the command to be ignored and the NOTPERF\_CMD flag to rise (see [Section 9.1.22](#)).

### 9.1.22 STATUS

**Table 34. STATUS register**

<b>Bit 15</b>	<b>Bit 14</b>	<b>Bit 13</b>	<b>Bit 12</b>	<b>Bit 11</b>	<b>Bit 10</b>	<b>Bit 9</b>	<b>Bit 8</b>
SCK_MOD	STEP_LOSS_B	STEP_LOSS_A	OCD	TH_SD	TH_WRN	UVLO	WRONG_CMD
<b>Bit 7</b>	<b>Bit 6</b>	<b>Bit 5</b>	<b>Bit 4</b>	<b>Bit 3</b>	<b>Bit 2</b>	<b>Bit 1</b>	<b>Bit 0</b>
NOTPERF_CMD	MOT_STATUS		DIR	SW_EVN	SW_F	BUSY	HiZ

When the HiZ flag is high, it indicates that the bridges are in high impedance state. Any motion command makes the device exit from High Z state (HardStop and SoftStop included), unless error flags forcing a High Z state are active.

The UVLO flag is active low and is set by an undervoltage lockout or reset events (power-up included).

The TH\_WRN, TH\_SD, OCD flags are active low and indicate, respectively, thermal warning, thermal shutdown and overcurrent detection events.

STEP\_LOSS\_A and STEP\_LOSS\_B flags are forced low when a stall is detected on bridge A or bridge B respectively.

The NOTPERF\_CMD and WRONG\_CMD flags are active high and indicate, respectively, that the command received by SPI cannot be performed or does not exist at all.

The SW\_F flag reports the SW input status (low for open and high for closed).

The SW\_EVN flag is active high and indicates a switch turn-on event (SW input falling edge).

The UVLO, TH\_WRN, TH\_SD, OCD, STEP\_LOSS\_A, STEP\_LOSS\_B, NOTPERF\_CMD, WRONG\_CMD and SW\_EVN flags are latched: when the respective conditions make them active (low or high), they remain in that state until a GetStatus command is sent to the IC.

The BUSY bit reflects the  $\overline{\text{BUSY}}$  pin status. The BUSY flag is low when a constant speed, positioning or motion command is under execution and is released (high) after the command has been completed.

The SCK\_MOD bit is an active high flag indicating that the device is working in Step-clock mode. In this case the step-clock signal should be provided through the STCK input pin. The DIR bit indicates the current motor direction:

**Table 35. STATUS register DIR bit**

<b>DIR</b>	<b>Motor direction</b>
1	Forward
0	Reverse

MOT\_STATUS indicates the current motor status:

**Table 36. STATUS register MOT\_STATE bits**

MOT_STATUS		Motor status
0	0	Stopped
0	1	Acceleration
1	0	Deceleration
1	1	Constant speed

Any attempt to write to the register causes the command to be ignored and the NOTPERF\_CMD flag to rise (see [Section 9.1.22](#)).

## 9.2 Application commands

The command summary is given in [Table 37](#).

**Table 37. Application commands**

Command mnemonic	Command binary code					Action
	[7..5]	[4]	[3]	[2..1]	[0]	
NOP	000	0	0	00	0	Nothing
SetParam(PARAM,VALUE)	000	[PARAM]				Writes VALUE in PARAM register
GetParam(PARAM)	001	[PARAM]				Returns the stored value in PARAM register
Run(DIR,SPD)	010	1	0	00	DIR	Sets the target speed and the motor direction
StepClock(DIR)	010	1	1	00	DIR	Puts the device into Step-clock mode and imposes DIR direction
Move(DIR,N_STEP)	010	0	0	00	DIR	Makes N_STEP (micro)steps in DIR direction (Not performable when motor is running)
GoTo(ABS_POS)	011	0	0	00	0	Brings motor into ABS_POS position (minimum path)
GoTo_DIR(DIR,ABS_POS)	011	0	1	00	DIR	Brings motor into ABS_POS position forcing DIR direction
GoUntil(ACT,DIR,SPD)	100	0	ACT	01	DIR	Performs a motion in DIR direction with speed SPD until SW is closed, the ACT action is executed then a SoftStop takes place.
ReleaseSW(ACT, DIR)	100	1	ACT	01	DIR	Performs a motion in DIR direction at minimum speed until the SW is released (open), the ACT action is executed then a HardStop takes place.
GoHome	011	1	0	00	0	Brings the motor into HOME position
GoMark	011	1	1	00	0	Brings the motor into MARK position
ResetPos	110	1	1	00	0	Resets the ABS_POS register (set HOME position)
ResetDevice	110	0	0	00	0	Device is reset to power-up conditions.
SoftStop	101	1	0	00	0	Stops motor with a deceleration phase

**Table 37. Application commands (continued)**

Command mnemonic	Command binary code					Action
	[7..5]	[4]	[3]	[2..1]	[0]	
HardStop	101	1	1	00	0	Stops motor immediately
SoftHiZ	101	0	0	00	0	Puts the bridges into high impedance status after a deceleration phase
HardHiZ	101	0	1	00	0	Puts the bridges into high impedance status immediately
GetStatus	110	1	0	00	0	Returns the STATUS register value
RESERVED	111	0	1	01	1	RESERVED COMMAND
RESERVED	111	1	1	00	0	RESERVED COMMAND

### 9.2.1 Command management

The host microcontroller can control motor motion and configure the L6470 through a complete set of commands.

All commands are composed by a single byte. After the command byte, some bytes of arguments should be needed (see [Figure 20](#)). Argument length can vary from 1 to 3 bytes.

**Figure 20. Command with 3-byte argument**

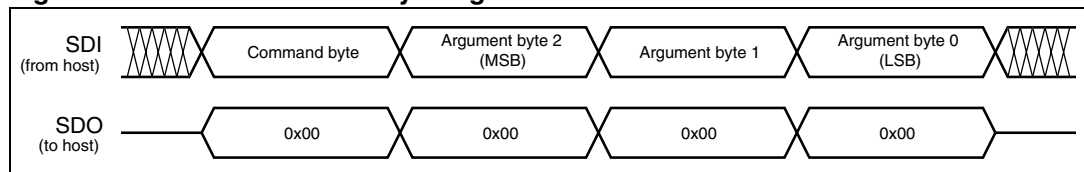

By default, the device returns an all zero response for any received byte, the only exceptions are the GetParam and GetStatus commands. When one of these commands is received, the following response bytes represent the related register value (see [Figure 21](#)). Response length can vary from 1 to 3 bytes.

**Figure 21. Command with 3-byte response**

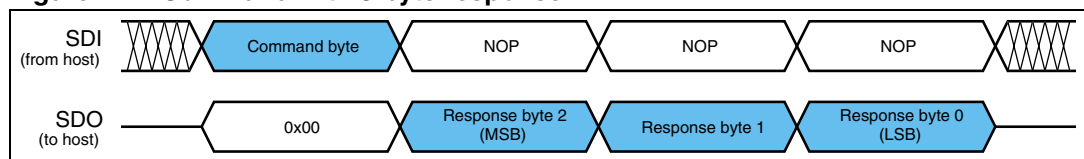

During response transmission, new commands can be sent. If a command requiring a response is sent before the previous response is completed, the response transmission is aborted and the new response is loaded into the output communication buffer (see [Figure 22](#)).

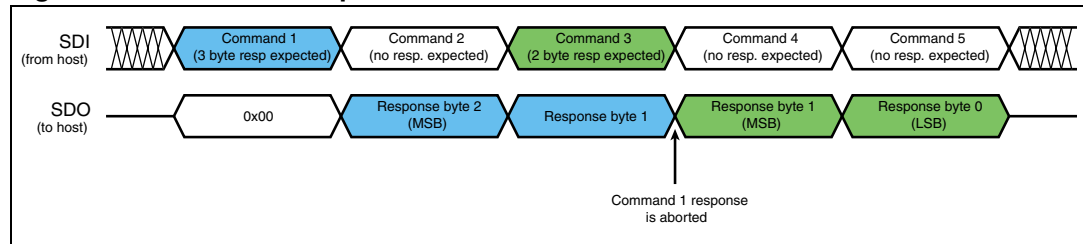
**Figure 22. Command response aborted**

When a byte that does not correspond to a command is sent to the IC, it is ignored and the `WRONG_CMD` flag in the STATUS register is raised (see [Section 9.1.22](#)).

## 9.2.2 Nop

**Table 38. Nop command structure**

Bit 7	Bit 6	Bit 5	Bit 4	Bit 3	Bit 2	Bit 1	Bit 0	
0	0	0	0	0	0	0	0	from host

Nothing is performed.

## 9.2.3 SetParam (PARAM, VALUE)

**Table 39. SetParam command structure**

Bit 7	Bit 6	Bit 5	Bit 4	Bit 3	Bit 2	Bit 1	Bit 0		
0	0	0	PARAM				from host		
VALUE Byte 2 (if needed)									
VALUE Byte 1 (if needed)									
VALUE Byte 0									

The SetParam command sets the PARAM register value equal to VALUE; PARAM is the respective register address listed in [Table 12](#).

The command should be followed by the new register VALUE (most significant byte first). The number of bytes making up the VALUE argument depends on the length of the target register (see [Table 12](#)).

Some registers cannot be written (see [Table 12](#)); any attempt to write one of those registers causes the command to be ignored and the `WRONG_CMD` flag to rise at the end of the command byte as if an unknown command code were sent (see [Section 9.1.22](#)).

Some registers can only be written in particular conditions (see [Table 12](#)); any attempt to write one of those registers when the conditions are not satisfied causes the command to be ignored and the `NOTPERF_CMD` flag to rise at the end of the last argument byte (see [Section 9.1.22](#)).

Any attempt to set an inexistent register (wrong address value) causes the command to be ignored and the `WRONG_CMD` flag to rise at the end of the command byte as if an unknown command code were sent.

### 9.2.4 GetParam (PARAM)

**Table 40. GetParam command structure**

Bit 7	Bit 6	Bit 5	Bit 4	Bit 3	Bit 2	Bit 1	Bit 0		
0	0	1	PARAM						from host
ANS Byte 2 (if needed)								to host	
ANS Byte 1 (if needed)								to host	
ANS Byte 0								to host	

This command reads the current PARAM register value; PARAM is the respective register address listed in [Table 12](#).

The command response is the current value of the register (most significant byte first). The number of bytes making up the command response depends on the length of the target register (see [Table 12](#)).

The returned value is the register one at the moment of GetParam command decoding. If register values change after this moment, the response is not accordingly updated.

All registers can be read anytime.

Any attempt to read an inexistent register (wrong address value) causes the command to be ignored and the WRONG\_CMD flag to rise at the end of the command byte as if an unknown command code were sent.

### 9.2.5 Run (DIR, SPD)

**Table 41. Run command structure**

Bit 7	Bit 6	Bit 5	Bit 4	Bit 3	Bit 2	Bit 1	Bit 0	
0	1	0	1	0	0	0	DIR	from host
X	X	X	X	SPD (Byte 2)				from host
SPD (Byte 1)								from host
SPD (Byte 0)								from host

The Run command produces a motion at SPD speed; the direction is selected by the DIR bit: '1' forward or '0' reverse. The SPD value is expressed in step/tick (format unsigned fixed point 0.28) that is the same format as the SPEED register (see [Section 9.1.4](#)).

*Note: The SPD value should be lower than MAX\_SPEED and greater than MIN\_SPEED otherwise the Run command is executed at MAX\_SPEED or MIN\_SPEED respectively.*

This command keeps the BUSY flag low until the target speed is reached.

This command can be given anytime and is immediately executed.

## 9.2.6 StepClock (DIR)

**Table 42. Stepclock command structure**

Bit 7	Bit 6	Bit 5	Bit 4	Bit 3	Bit 2	Bit 1	Bit 0	
0	1	0	1	1	0	0	DIR	from host

The StepClock command switches the device in Step-clock mode (see [Section 6.7.5](#)) and imposes the forward (DIR = '1') or reverse (DIR = '0') direction.

When the device is in Step-clock mode, the SCK\_MOD flag in the STATUS register is raised and the motor is always considered stopped (see [Section 6.7.5](#) and [9.1.22](#)).

The device exits from Step-clock mode when a constant speed, absolute positioning or motion command is sent through SPI. Motion direction is imposed by the respective StepClock command argument and can be changed by a new StepClock command without exiting Step-clock mode.

Events that cause bridges to be forced into high impedance state (overtemperature, overcurrent, etc.) do not cause the device to leave Step-clock mode.

The StepClock command does not force the BUSY flag low. This command can only be given when the motor is stopped. If a motion is in progress, the motor should be stopped and it is then possible to send a StepClock command.

Any attempt to perform a StepClock command when the motor is running causes the command to be ignored and the NOTPERF\_CMD flag to rise (see [Section 9.1.22](#)).

## 9.2.7 Move (DIR, N\_STEP)

**Table 43. Move command structure**

Bit 7	Bit 6	Bit 5	Bit 4	Bit 3	Bit 2	Bit 1	Bit 0		
0	1	0	0	0	0	0	DIR	from host	
X	X	N_STEP (Byte 2)							from host
								N_STEP (Byte 1)	from host
								N_STEP (Byte 0)	from host

The Move command produces a motion of N\_STEP microsteps; the direction is selected by the DIR bit ('1' forward or '0' reverse).

The N\_STEP value is always in agreement with the selected step mode; the parameter value unit is equal to the selected step mode (full, half, quarter, etc.).

This command keeps the BUSY flag low until the target number of steps is performed. This command can only be performed when the motor is stopped. If a motion is in progress, the motor must be stopped and it is then possible to perform a Move command.

Any attempt to perform a Move command when the motor is running causes the command to be ignored and the NOTPERF\_CMD flag to rise (see [Section 9.1.22](#)).

### 9.2.8 GoTo (ABS\_POS)

**Table 44. GoTo command structure**

Bit 7	Bit 6	Bit 5	Bit 4	Bit 3	Bit 2	Bit 1	Bit 0	
0	1	1	0	0	0	0	0	from host
X	X	ABS_POS (Byte 2)						from host
ABS_POS (Byte 1)								from host
ABS_POS (Byte 0)								from host

The GoTo command produces a motion to ABS\_POS absolute position through the shortest path. The ABS\_POS value is always in agreement with the selected step mode; the parameter value unit is equal to the selected step mode (full, half, quarter, etc.).

The GoTo command keeps the BUSY flag low until the target position is reached.

This command can be given only when the previous motion command has been completed (BUSY flag released).

Any attempt to perform a GoTo command when a previous command is under execution (BUSY low) causes the command to be ignored and the NOTPERF\_CMD flag to rise (see [Section 9.1.22](#)).

### 9.2.9 GoTo\_DIR (DIR, ABS\_POS)

**Table 45. GoTo\_DIR command structure**

Bit 7	Bit 6	Bit 5	Bit 4	Bit 3	Bit 2	Bit 1	Bit 0	
0	1	1	0	1	0	0	DIR	from host
X	X	ABS_POS (Byte 2)						from host
ABS_POS (Byte 1)								from host
ABS_POS (Byte 0)								from host

The GoTo\_DIR command produces a motion to ABS\_POS absolute position imposing a forward (DIR = '1') or a reverse (DIR = '0') rotation. The ABS\_POS value is always in agreement with the selected step mode; the parameter value unit is equal to the selected step mode (full, half, quarter, etc.).

The GoTo\_DIR command keeps the BUSY flag low until the target speed is reached. This command can be given only when the previous motion command has been completed (BUSY flag released).

Any attempt to perform a GoTo\_DIR command when a previous command is under execution (BUSY low) causes the command to be ignored and the NOTPERF\_CMD flag to rise (see [Section 9.1.22](#)).

### 9.2.10 GoUntil (ACT, DIR, SPD)

**Table 46. GoUntil command structure**

Bit 7	Bit 6	Bit 5	Bit 4	Bit 3	Bit 2	Bit 1	Bit 0	
1	0	0	0	ACT	0	1	DIR	from host
X	X	X	X	SPD (Byte 2)				from host
SPD (Byte 1)								from host
SPD (Byte 0)								from host

The GoUntil command produces a motion at SPD speed imposing a forward (DIR = '1') or a reverse (DIR = '0') direction. When an external switch turn-on event occurs (see [Section 6.13](#)), the ABS\_POS register is reset (if ACT = '0') or the ABS\_POS register value is copied into the MARK register (if ACT = '1'); then the system performs a SoftStop command.

The SPD value is expressed in step/tick (format unsigned fixed point 0.28) that is the same format as the SPEED register (see [Section 9.1.4](#)).

The SPD value should be lower than MAX\_SPEED and greater than MIN\_SPEED, otherwise the target speed is imposed at MAX\_SPEED or MIN\_SPEED respectively.

If the SW\_MODE bit of the CONFIG register is set low, the external switch turn-on event causes a HardStop interrupt instead of the SoftStop one (see [Section 6.13](#) and [9.1.21](#)).

This command keeps the BUSY flag low until the switch turn-on event occurs and the motor is stopped. This command can be given anytime and is immediately executed.

### 9.2.11 ReleaseSW (ACT, DIR)

**Table 47. ReleaseSW command structure**

Bit 7	Bit 6	Bit 5	Bit 4	Bit 3	Bit 2	Bit 1	Bit 0	
1	0	0	1	ACT	0	1	DIR	from host

The ReleaseSW command produces a motion at minimum speed imposing a forward (DIR = '1') or reverse (DIR = '0') rotation. When SW is released (opened), the ABS\_POS register is reset (ACT = '0') or the ABS\_POS register value is copied into the MARK register (ACT = '1'); the system then performs a HardStop command.

Note that resetting the ABS\_POS register is equivalent to setting the HOME position.

If the minimum speed value is less than 5 step/s or low speed optimization is enabled, the motion is performed at 5 step/s.

The ReleaseSW command keeps the BUSY flag low until the switch input is released and the motor is stopped.

### 9.2.12 GoHome

**Table 48. GoHome command structure**

Bit 7	Bit 6	Bit 5	Bit 4	Bit 3	Bit 2	Bit 1	Bit 0	
0	1	1	1	0	0	0	0	from host

The GoHome command produces a motion to the HOME position (zero position) via the shortest path.

Note that this command is equivalent to the “GoTo(0...0)” command. If a motor direction is mandatory, the GoTo\_DIR command must be used (see [Section 9.2.9](#)).

The GoHome command keeps the BUSY flag low until the home position is reached. This command can be given only when the previous motion command has been completed. Any attempt to perform a GoHome command when a previous command is under execution (BUSY low) causes the command to be ignored and the NOTPERF\_CMD to rise (see [Section 9.1.22](#)).

### 9.2.13 GoMark

**Table 49. GoMark command structure**

Bit 7	Bit 6	Bit 5	Bit 4	Bit 3	Bit 2	Bit 1	Bit 0	
0	1	1	1	1	0	0	0	from host

The GoMark command produces a motion to the MARK position performing the minimum path.

Note that this command is equivalent to the “GoTo (MARK)” command. If a motor direction is mandatory, the GoTo\_DIR command must be used.

The GoMark command keeps the BUSY flag low until the MARK position is reached. This command can be given only when the previous motion command has been completed (BUSY flag released).

Any attempt to perform a GoMark command when a previous command is under execution (BUSY low) causes the command to be ignored and the NOTPERF\_CMD flag to rise (see [Section 9.1.22](#)).

### 9.2.14 ResetPos

**Table 50. ResetPos command structure**

Bit 7	Bit 6	Bit 5	Bit 4	Bit 3	Bit 2	Bit 1	Bit 0	
1	1	0	1	1	0	0	0	from host

The ResetPos command resets the ABS\_POS register to zero. The zero position is also defined as HOME position (see [Section 6.5](#)).

### 9.2.15 ResetDevice

**Table 51. ResetDevice command structure**

Bit 7	Bit 6	Bit 5	Bit 4	Bit 3	Bit 2	Bit 1	Bit 0	
1	1	0	0	0	0	0	0	from host

The ResetDevice command resets the device to power-up conditions (see [Section 6.1](#)).

*Note:* At power-up the power bridges are disabled.

### 9.2.16 SoftStop

**Table 52. SoftStop command structure**

Bit 7	Bit 6	Bit 5	Bit 4	Bit 3	Bit 2	Bit 1	Bit 0	
1	0	1	1	0	0	0	0	from host

The SoftStop command causes an immediate deceleration to zero speed and a consequent motor stop; the deceleration value used is the one stored in the DEC register (see [Section 9.1.6](#)).

When the motor is in high impedance state, a SoftStop command forces the bridges to exit from high impedance state; no motion is performed.

This command can be given anytime and is immediately executed. This command keeps the BUSY flag low until the motor is stopped.

### 9.2.17 HardStop

**Table 53. HardStop command structure**

Bit 7	Bit 6	Bit 5	Bit 4	Bit 3	Bit 2	Bit 1	Bit 0	
1	0	1	1	1	0	0	0	from host

The HardStop command causes an immediate motor stop with infinite deceleration.

When the motor is in high impedance state, a HardStop command forces the bridges to exit from high impedance state; no motion is performed.

This command can be given anytime and is immediately executed. This command keeps the BUSY flag low until the motor is stopped.

### 9.2.18 SoftHiZ

**Table 54. SoftHiZ command structure**

Bit 7	Bit 6	Bit 5	Bit 4	Bit 3	Bit 2	Bit 1	Bit 0	
1	0	1	0	0	0	0	0	from host

The SoftHiZ command disables the power bridges (high impedance state) after a deceleration to zero; the deceleration value used is the one stored in the DEC register (see [Section 9.1.6](#)). When bridges are disabled, the HiZ flag is raised.

When the motor is stopped, a SoftHiZ command forces the bridges to enter into high impedance state.

This command can be given anytime and is immediately executed. This command keeps the BUSY flag low until the motor is stopped.

### 9.2.19 HardHiZ

**Table 55. HardHiZ command structure**

Bit 7	Bit 6	Bit 5	Bit 4	Bit 3	Bit 2	Bit 1	Bit 0	
1	0	1	0	1	0	0	0	from host

The HardHiZ command immediately disables the power bridges (high impedance state) and raises the HiZ flag.

When the motor is stopped, a HardHiZ command forces the bridges to enter into high impedance state.

This command can be given anytime and is immediately executed. This command keeps the BUSY flag low until the motor is stopped.

### 9.2.20 GetStatus

**Table 56. GetStatus command structure**

Bit 7	Bit 6	Bit 5	Bit 4	Bit 3	Bit 2	Bit 1	Bit 0	
1	1	0	1	0	0	0	0	from host
STATUS MSByte								to host
STATUS LSByte								to host

The GetStatus command returns the STATUS register value.

The GetStatus command resets the STATUS register warning flags. The command forces the system to exit from any error state. The GetStatus command DOES NOT reset the HiZ flag.

## 10 Package mechanical data

In order to meet environmental requirements, ST offers these devices in different grades of ECOPACK<sup>®</sup> packages, depending on their level of environmental compliance. ECOPACK<sup>®</sup> specifications, grade definitions and product status are available at: [www.st.com](http://www.st.com). ECOPACK<sup>®</sup> is an ST trademark.

**Table 57. HTSSOP28 mechanical data**

Dim.	mm		
	Min.	Typ.	Max.
A			1.2
A1			0.15
A2	0.8	1.0	1.05
b	0.19		0.3
c	0.09		0.2
D <sup>(1)</sup>	9.6	9.7	9.8
D1		5.5	
E	6.2	6.4	6.6
E1 <sup>(2)</sup>	4.3	4.4	4.5
E2		2.8	
E		0.65	
L	0.45	0.6	0.75
L1		1.0	
K	0°		8°
Aaa		0.1	

1. Dimension "D" does not include mold flash, protrusions or gate burrs. Mold flash, protrusions or gate burrs must not exceed 0.15 mm per side.
2. Dimension "E1" does not include interlead flash or protrusions. Interlead flash or protrusions must not exceed 0.25 mm per side.

Figure 23. HTSSOP28 mechanical data

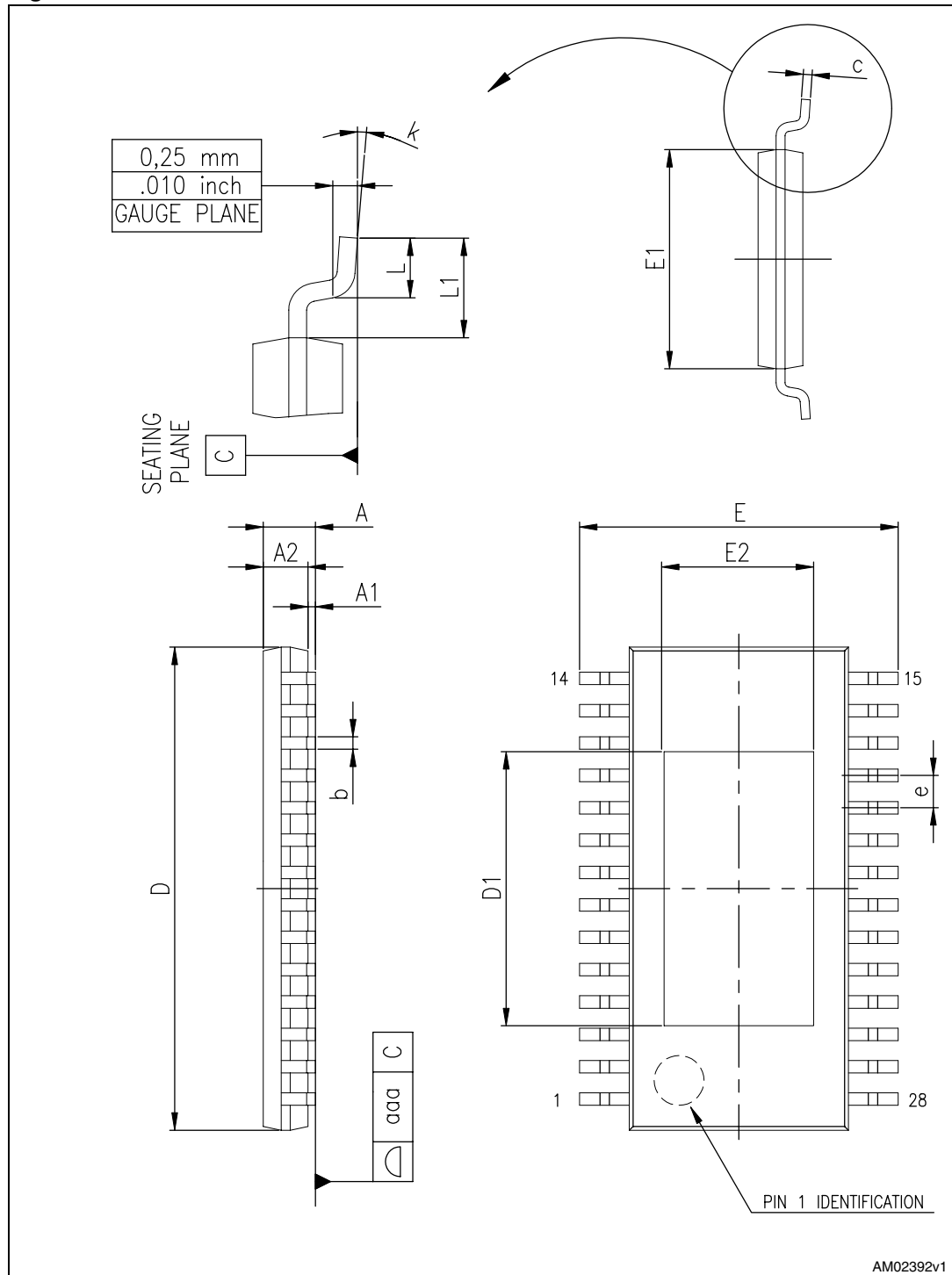

AM02392v1

Table 58. POWERSO36 mechanical data

Dim.	mm		
	Min.	Typ.	Max.
A			3.60
a1	0.10		0.30
a2			3.30
a3	0		0.10
b	0.22		0.38
c	0.23		0.32
D(1)	15.80		16.00
D1	9.40		9.80
E	13.90		14.50
E1(1)	10.90		11.10
E2			2.90
E3	5.8		6.2
e		0.65	
e3		11.05	
G	0		0.10
H	15.50		15.90
h			1.10
L	0.80		1.10
N			10°
S	0°		8°

Figure 24. POWERSO36 drawings

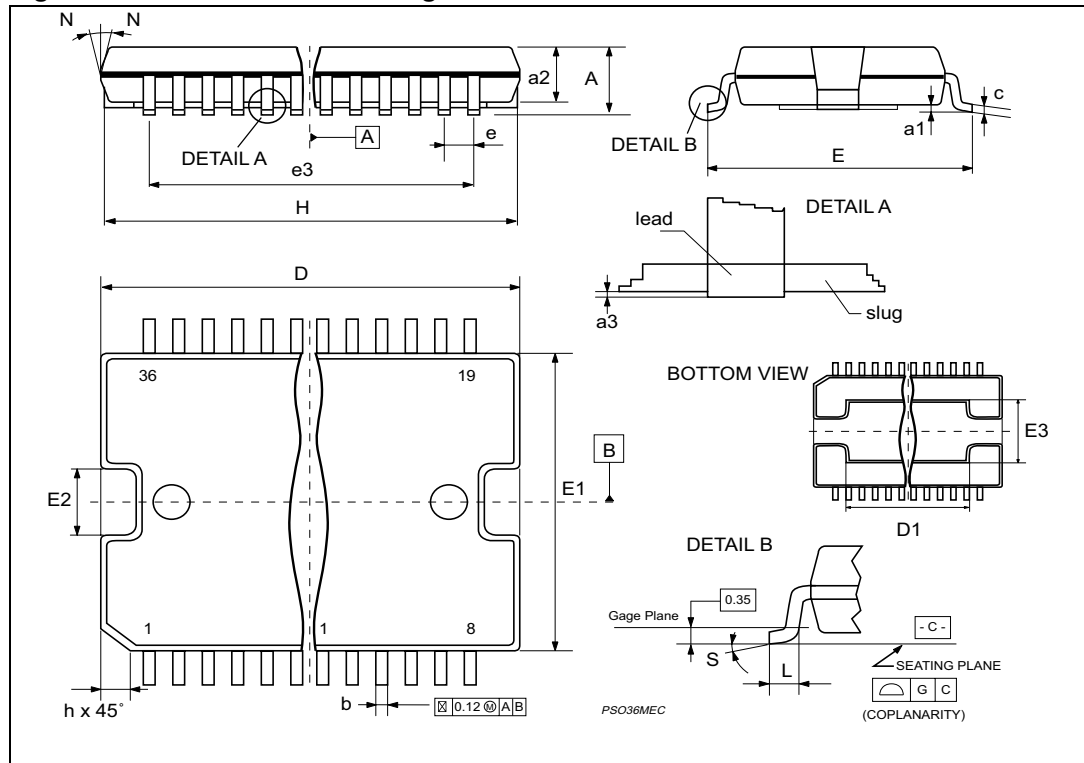

## 11 Revision history

**Table 59. Revision history**

Date	Revision	Changes
06-Nov-2009	1	Initial release
05-Nov-2010	2	Document status promoted from preliminary data to datasheet
18-May-2011	3	Updated: <a href="#">Table 4</a> , <a href="#">Table 5</a> Added: <a href="#">Section 6.7.6</a> , <a href="#">Section 6.4.1</a>
19-Jun-2012	4	Added device in POWERSO36 and <a href="#">Figure 3</a> Updated: <a href="#">Table 2</a> , <a href="#">Table 3</a> , <a href="#">Table 4</a> , <a href="#">Table 5</a> , <a href="#">Table 6</a> , <a href="#">Table 9</a> and <a href="#">Section 9.1.11</a> . Minor text changes.

**Please Read Carefully:**

Information in this document is provided solely in connection with ST products. STMicroelectronics NV and its subsidiaries ("ST") reserve the right to make changes, corrections, modifications or improvements, to this document, and the products and services described herein at any time, without notice.

All ST products are sold pursuant to ST's terms and conditions of sale.

Purchasers are solely responsible for the choice, selection and use of the ST products and services described herein, and ST assumes no liability whatsoever relating to the choice, selection or use of the ST products and services described herein.

No license, express or implied, by estoppel or otherwise, to any intellectual property rights is granted under this document. If any part of this document refers to any third party products or services it shall not be deemed a license grant by ST for the use of such third party products or services, or any intellectual property contained therein or considered as a warranty covering the use in any manner whatsoever of such third party products or services or any intellectual property contained therein.

**UNLESS OTHERWISE SET FORTH IN ST'S TERMS AND CONDITIONS OF SALE ST DISCLAIMS ANY EXPRESS OR IMPLIED WARRANTY WITH RESPECT TO THE USE AND/OR SALE OF ST PRODUCTS INCLUDING WITHOUT LIMITATION IMPLIED WARRANTIES OF MERCHANTABILITY, FITNESS FOR A PARTICULAR PURPOSE (AND THEIR EQUIVALENTS UNDER THE LAWS OF ANY JURISDICTION), OR INFRINGEMENT OF ANY PATENT, COPYRIGHT OR OTHER INTELLECTUAL PROPERTY RIGHT.**

**UNLESS EXPRESSLY APPROVED IN WRITING BY TWO AUTHORIZED ST REPRESENTATIVES, ST PRODUCTS ARE NOT RECOMMENDED, AUTHORIZED OR WARRANTED FOR USE IN MILITARY, AIR CRAFT, SPACE, LIFE SAVING, OR LIFE SUSTAINING APPLICATIONS, NOR IN PRODUCTS OR SYSTEMS WHERE FAILURE OR MALFUNCTION MAY RESULT IN PERSONAL INJURY, DEATH, OR SEVERE PROPERTY OR ENVIRONMENTAL DAMAGE. ST PRODUCTS WHICH ARE NOT SPECIFIED AS "AUTOMOTIVE GRADE" MAY ONLY BE USED IN AUTOMOTIVE APPLICATIONS AT USER'S OWN RISK.**

Resale of ST products with provisions different from the statements and/or technical features set forth in this document shall immediately void any warranty granted by ST for the ST product or service described herein and shall not create or extend in any manner whatsoever, any liability of ST.

ST and the ST logo are trademarks or registered trademarks of ST in various countries.

Information in this document supersedes and replaces all information previously supplied.

The ST logo is a registered trademark of STMicroelectronics. All other names are the property of their respective owners.

© 2012 STMicroelectronics - All rights reserved

STMicroelectronics group of companies

Australia - Belgium - Brazil - Canada - China - Czech Republic - Finland - France - Germany - Hong Kong - India - Israel - Italy - Japan - Malaysia - Malta - Morocco - Philippines - Singapore - Spain - Sweden - Switzerland - United Kingdom - United States of America

[www.st.com](http://www.st.com)