

## Up to 1A step down switching regulator

### Features

- Up to 1A output current
- Operating input voltage from 4.4V to 36V
- 3.3V / ( $\pm 2\%$ ) reference voltage
- Output voltage adjustable from 1.2V to 35V
- Low dropout operation: 100% duty cycle
- 250KHz Internally fixed frequency
- Voltage feedforward
- Zero load current operation
- Internal current limiting
- Inhibit for zero current consumption
- Synchronization
- Protection against feedback disconnection
- Thermal shutdown

### Applications

- Consumer: STB, DVD, TV, VCR, car radio, LCD monitors
- Networking: XDSL, modems, DC-DC modules
- Computer: printers, audio/graphic cards, optical storage, hard disk drive
- Industrial: changers, car battery, DC-DC converters

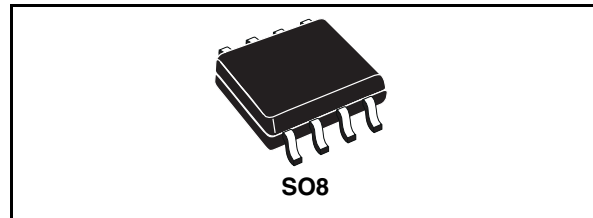

### Description

The L5970D is a step down monolithic power switching regulator capable to deliver up to 1A at output voltages from 1.2V to 35V.

The device uses an internal P-Channel D-MOS transistor (with a typical  $R_{dson}$  of 250m $\Omega$ ) as switching element to minimize the size of the external components.

An internal oscillator fixes the switching frequency at 250KHz.

Having a minimum input voltage of 4.4V only, it is particularly suitable for 5V bus, available in all computer related applications.

Pulse by pulse current limit with the internal frequency modulation offers an effective constant current short circuit protection.

**Figure 1. Test application circuit**

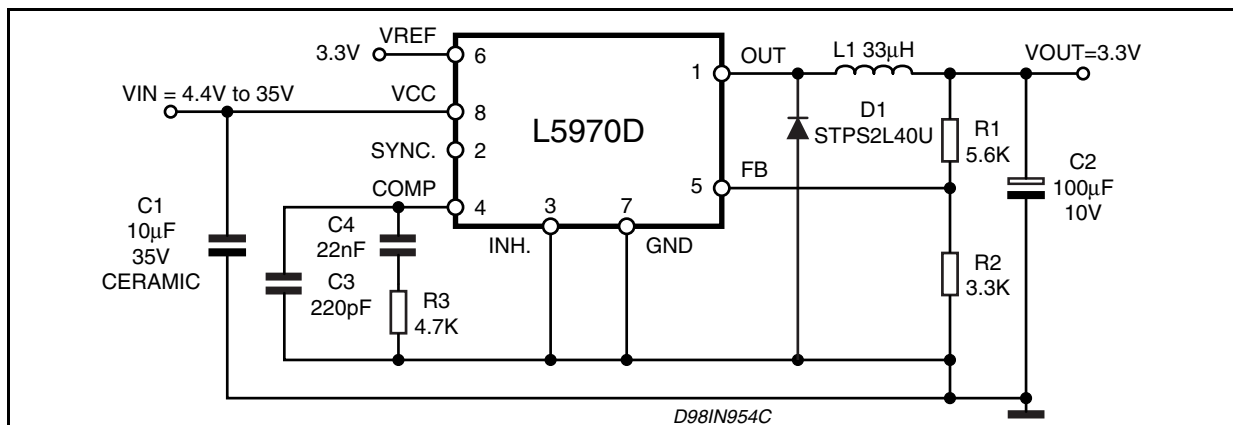

## 2 Electrical data

### 2.1 Maximum ratings

**Table 2. Absolute maximum ratings**

Symbol	Parameter	Value	Unit
$V_8$	Input voltage	40	V
$V_1$	Output DC voltage Output peak voltage at $t = 0.1\mu\text{s}$	-1 to 40 -5 to 40	V V
$I_1$	Maximum output current	int. limit.	
$V_4, V_5$	Analog pins	4	V
$V_3$	INH	-0.3V to $V_{CC}$	
$V_2$	SYNC	-0.3 to 4	V
$P_{TOT}$	Power dissipation at $T_A \leq 60^\circ\text{C}$	0.75	W
$T_J$	Operating junction temperature range	-40 to 150	$^\circ\text{C}$
$T_{STG}$	Storage temperature range	-55 to 150	$^\circ\text{C}$

### 2.2 Thermal data

**Table 3. Thermal data**

Symbol	Parameter	SO8	Unit
$R_{thJA}$	Maximum thermal resistance junction-ambient	120 <sup>(1)</sup>	$^\circ\text{C}/\text{W}$

1. Package mounted on board

### 3 Electrical characteristics

**Table 4. Electrical characteristics**

 (  $T_J = 25^\circ\text{C}$ ,  $V_{CC} = 12\text{V}$ , unless otherwise specified)

Symbol	Parameter	Test condition	Min	Typ	Max	Unit	
$V_{CC}$	Operating input voltage range	$V_O = 1.235\text{V}$ ; $I_O = 2\text{A}$	(1)	4.4		36	V
$R_{DS(on)}$	Mosfet on Resistance		(1)		0.250	0.5	$\Omega$
$I_l$	Maximum limiting current	$V_{CC} = 4.4\text{V to } 36\text{V}$		1.5	1.87	2.25	A
$f_s$	Switching frequency		(1)	212	250	280	KHz
				225	250	275	KHz
	Duty cycle			0		100	%
<b>Dynamic characteristics</b> (see test circuit ).							
$V_5$	Voltage feedback	$4.4\text{V} < V_{CC} < 36\text{V}$ , $20\text{mA} < I_O < 2\text{A}$		1.220	1.235	1.25	V
			(1)	1.198	1.235	1.272	V
$h$	Efficiency	$V_O = 5\text{V}$ , $V_{CC} = 12\text{V}$			90		%
<b>DC characteristics</b>							
$I_{qop}$	Total operating quiescent current		(1)		3	5	mA
$I_q$	Quiescent current	Duty cycle = 0; $V_{FB} = 1.5\text{V}$				2.5	mA
$I_{qst-by}$	Total stand-by quiescent current	$V_{inh} > 2.2\text{V}$	(1)		50	100	$\mu\text{A}$
		$V_{CC} = 36\text{V}$ ; $V_{inh} > 2.2\text{V}$	(1)		80	150	$\mu\text{A}$
<b>Inhibit</b>							
	INH threshold voltage	Device ON				0.8	V
		Device OFF		2.2			V
<b>Error amplifier</b>							
$V_{OH}$	High level output voltage	$V_{FB} = 1\text{V}$		3.5			V
$V_{OL}$	Low level output voltage	$V_{FB} = 1.5\text{V}$				0.4	V
$I_{o\ source}$	Source output current	$V_{COMP} = 1.9\text{V}$ ; $V_{FB} = 1\text{V}$		200	300		$\mu\text{A}$

**Table 4. Electrical characteristics** (continued)  
 (  $T_J = 25^\circ\text{C}$ ,  $V_{CC} = 12\text{V}$ , unless otherwise specified)

Symbol	Parameter	Test condition	Min	Typ	Max	Unit	
$I_{o\text{ sink}}$	Sink output current	$V_{\text{COMP}} = 1.9\text{V};$ $V_{\text{FB}} = 1.5\text{V}$	1	1.5		mA	
$I_b$	Source bias current			2.5	4	$\mu\text{A}$	
	DC open loop gain	$R_L = \infty$	50	65		dB	
$g_m$	Transconductance	$I_{\text{comp}} = -0.1\text{mA}$ to $0.1\text{mA}$ $V_{\text{COMP}} = 1.9\text{V}$		2.3		mS	
<b>Sync function</b>							
	High input voltage	$V_{CC} = 4.4\text{V}$ to $36\text{V}$	2.5		$V_{\text{REF}}$	V	
	Low input voltage	$V_{CC} = 4.4\text{V}$ to $36\text{V}$			0.74	V	
	Slave sink current	$V_{\text{sync}} = 0.74\text{V}$ (2) $V_{\text{sync}} = 2.33\text{V}$	0.11 0.21		0.25 0.45	mA mA	
	Master output amplitude	$I_{\text{source}} = 3\text{mA}$	2.75	3		V	
	Output pulse width	no load, $V_{\text{sync}} = 1.65\text{V}$	0.20	0.35		$\mu\text{s}$	
<b>Reference section</b>							
	Reference voltage		3.234	3.3	3.366	V	
		$I_{\text{REF}} = 0$ to $5\text{mA}$ $V_{CC} = 4.4\text{V}$ to $36\text{V}$	(1)	3.2	3.3	3.399	V
	Line regulation	$I_{\text{REF}} = 0\text{mA}$ $V_{CC} = 4.4\text{V}$ to $36\text{V}$		5	10	mV	
	Load regulation	$I_{\text{REF}} = 0$ to $5\text{mA}$		8	15	mV	
	Short circuit current		10	18	30	mA	

1. Specification Referred to  $T_J$  from  $-40$  to  $125^\circ\text{C}$ . Specification over the  $-40$  to  $+125 T_J$  Temperature range are assured by design, characterization and statistical correlation.

2. Guaranteed by design.

Table 6. SO-8 mechanical data

Dim.	mm.			inch		
	Min	Typ	Max	Min	Typ	Max
A	1.35		1.75	0.053		0.069
A1	0.10		0.25	0.004		0.010
A2	1.10		1.65	0.043		0.065
B	0.33		0.51	0.013		0.020
C	0.19		0.25	0.007		0.010
D (1)	4.80		5.00	0.189		0.197
E	3.80		4.00	0.15		0.157
e		1.27			0.050	
H	5.80		6.20	0.228		0.244
h	0.25		0.50	0.010		0.020
L	0.40		1.27	0.016		0.050
k	0° (min.), 8° (max.)					
ddd			0.10			0.004

1. Dimensions D does not include mold flash, protrusions or gate burrs. Mold flash, protrusions or gate burrs shall not exceed 0.15mm (.006inch) in total (both side).

Figure 22. Package dimensions

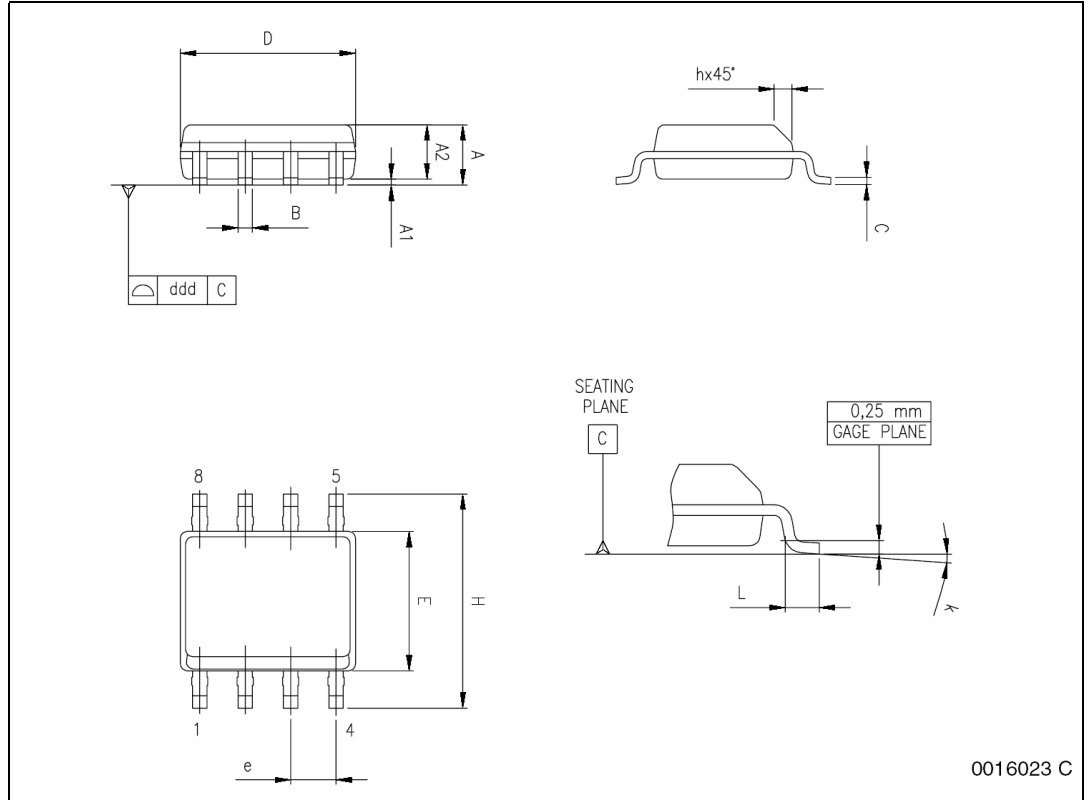

## 8 Order codes

**Table 7. Order codes**

Part number	Package	Packaging
L5970D	SO8	Tube
L5970D013TR	SO8	Tape and reel