



Isolated Profibus RS-485 Transceiver with Integrated Transformer Driver

Check for Samples: [ISO1176T](#)

FEATURES

- 3000V_{RMS} / 4242V_{PK} Isolation
- Meets or Exceeds the Requirements of EN 50170 and TIA/EIA RS-485
- Signaling Rates up to 40 Mbps
- Easy Isolated Power Design with Integrated Transformer Driver
- Typical Efficiency > 60% (I_{LOAD} = 100 mA) - see [sluu471](#)
- Differential Output exceeds 2.1V (54Ω Load)
- Low Bus Capacitance 10pF (MAX)
- 50kV/μs Typical Transient Immunity
- UL 1577, IEC 60747-5-2 (VDE 0884, Rev. 2) Approvals Pending
- Fail-safe Receiver for Bus Open, Short, or Idle

APPLICATIONS

- Profibus®
- Factory Automation
- Networked Sensors
- Motor/motion Control
- HVAC and Building Automation Networks
- Networked Security Stations

DESCRIPTION

The ISO1176T is an isolated differential line transceiver with integrated oscillator outputs that provide the primary voltage for an isolation transformer. The device is ideal for long transmission lines because the ground loop is broken to allow the device to operate with a much larger common-mode voltage range. The symmetrical isolation barrier of each device is tested to provide 4242V_{PK} of isolation per VDE for 60 seconds between the line transceiver and the logic-level interface.

The galvanically isolated differential bus transceiver is an integrated circuit designed for bi-directional data communication on multipoint bus-transmission lines. The transceiver combines a galvanically isolated differential line driver and differential input line receiver. The driver has an active-high enable with isolated enable-state output on the ISODE pin (pin 10) to facilitate direction control. The driver differential outputs and the receiver differential inputs connect internally to form a differential input/output (I/O) bus port that is designed to offer minimum loading to the bus whenever the driver is disabled or V_{CC2} = 0.

Any cabled I/O can be subjected to electrical noise transients from various sources. These noise transients can cause damage to the transceiver and/or near-by sensitive circuitry if they are of sufficient magnitude and duration. The ISO1176T can significantly reduce the risk of data corruption and damage to expensive control circuits.

The device is characterized for operation over the ambient temperature range of –40°C to 85°C.

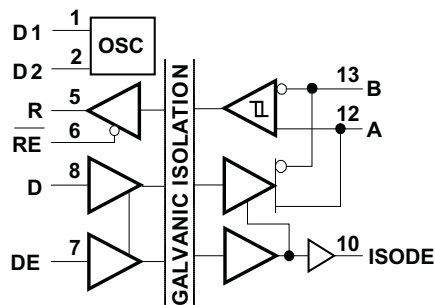
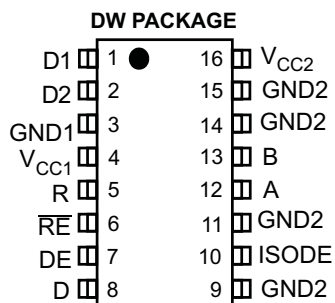

Please be aware that an important notice concerning availability, standard warranty, and use in critical applications of Texas Instruments semiconductor products and disclaimers thereto appears at the end of this data sheet.

Profibus is a registered trademark of Profibus International.



These devices have limited built-in ESD protection. The leads should be shorted together or the device placed in conductive foam during storage or handling to prevent electrostatic damage to the MOS gates.

DEVICE INFORMATION

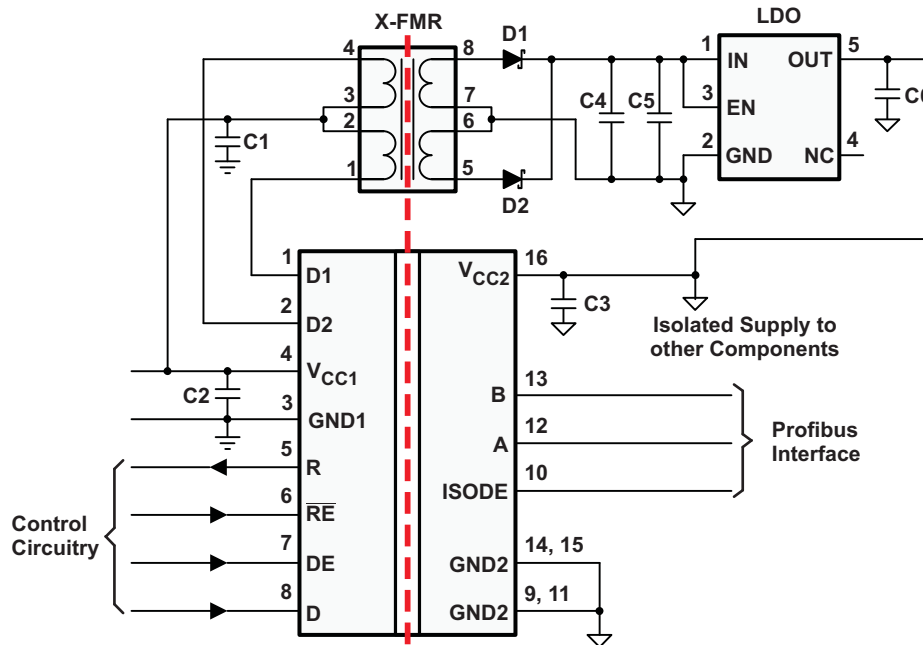

Figure 1. Typical Applications

PIN DESCRIPTIONS

NAME	PIN #	FUNCTION
D1	1	Transformer Driver Terminal 1, Open Drain Output
D2	2	Transformer Driver Terminal 2, Open Drain Output
GND1	3	Logic-side Ground
V _{CC1}	4	Logic-side Power Supply
R	5	Receiver Output
\overline{RE}	6	Receiver Enable Input. This pin has complementary logic.
DE	7	Driver Enable Input
D	8	Driver Input
GND2	9, 11, 14, 15	Bus-side Ground. All pins are internally connected.
ISODE	10	Bus-side Driver Enable Output Status
A	12	Non-inverting Driver Output / Receiver Input
B	13	Inverting Driver Output / Receiver Input
V _{CC2}	16	Bus-side Power Supply

ABSOLUTE MAXIMUM RATINGS⁽¹⁾

				VALUE	UNIT	
V_{CC1} , V_{CC2}	Input supply voltage ⁽²⁾			-0.5 to 7	V	
V_O	Voltage at any bus I/O terminal			-9 to 14	V	
	Voltage at D1, D2			14	V	
V_I	Voltage input at D, DE or \overline{RE} terminal			-0.5 to 7	V	
I_O	Receiver output current			± 10	mA	
I_{D1} , I_{D2}	Transformer Driver Output Current			450	mA	
ESD	Electrostatic Discharge	Human Body Model	JEDEC Standard 22, Test Method A114-C.01	Bus pins to GND1	± 6	kV
				Bus pins to GND2	± 10	
		all pins		± 4		
		Charged Device Model	JEDEC Standard 22, Test Method C101	all pins		± 1.5
Machine Model	ANSI/ESDS5.2-1996			± 200	V	
T_J	Maximum junction temperature			170	$^{\circ}\text{C}$	
T_{STG}	Storage temperature			-65 to 150	$^{\circ}\text{C}$	

- (1) Stresses beyond those listed under *absolute maximum ratings* may cause permanent damage to the device. These are stress ratings only and functional operation of the device at these or any other conditions beyond those indicated under *recommended operating conditions* is not implied. Exposure to absolute-maximum-rated conditions for extended periods may affect device reliability.
- (2) All voltage values except differential I/O bus voltages are with respect to the referenced network ground terminal and are peak voltage values.

RECOMMENDED OPERATING CONDITIONS

over operating free-air temperature range (unless otherwise noted)

			MIN	NOM	MAX	UNIT
V_{CC}	Logic side supply voltage, V_{CC1} (with respect to GND1)		3		5.5	V
	Bus side supply voltage, V_{CC2} (with respect to GND2)		4.75		5.25	
V_{CM}	Voltage at either bus I/O terminal		A, B		12	V
V_{IH}	High-level input voltage		\overline{RE}		V_{CC1}	V
			D, DE	$0.7 V_{CC1}$		
V_{IL}	Low-level input voltage		\overline{RE}	0	0.8	V
			D, DE		$0.3 V_{CC1}$	
V_{ID}	Differential input voltage		A with respect to B	-12	12	V
I_O	Output Current		RS-485 driver	-70	70	mA
			Receiver	-8	8	
T_A	Ambient temperature			-40	85	$^{\circ}\text{C}$
T_J	Operating junction temperature				150	$^{\circ}\text{C}$
$1 / t_{UI}$	Signaling Rate				40	Mbps

ISO1176T

SLLSE28E – OCTOBER 2010 – REVISED AUGUST 2011

www.ti.com

SUPPLY CURRENT

over operating free-air temperature range (unless otherwise noted)

PARAMETER		TEST CONDITIONS	MIN	TYP	MAX	UNIT
$I_{CC1}^{(1)}$	Logic-side quiescent supply current	$V_{CC1} = 3.3\text{ V} \pm 10\%$, DE, $\overline{RE} = 0\text{V}$ or V_{CC1} , No load		4.5	8	mA
		$V_{CC1} = 5\text{ V} \pm 10\%$, DE, $\overline{RE} = 0\text{V}$ or V_{CC1} , No load		7	11	mA
$I_{CC2}^{(1)}$	Bus-side quiescent supply current	$V_{CC2} = 5\text{ V} \pm 5\%$, DE, $\overline{RE} = 0\text{V}$ or V_{CC1} , No load		13.5	18	mA

(1) I_{CC1} and I_{CC2} are measured when device is connected to external power supplies. D1 and D2 are disconnected from external transformer.

ISODE-PIN ELECTRICAL CHARACTERISTICS

over operating free-air temperature range (unless otherwise noted)

PARAMETER		TEST CONDITIONS	MIN	TYP	MAX	UNIT
V_{OH}	High-level output voltage	$I_{OH} = -8\text{mA}$	$V_{CC2} - 0.8$	4.6		V
		$I_{OH} = -20\mu\text{A}$	$V_{CC2} - 0.1$	5		
V_{OL}	Low-level output voltage	$I_{OL} = 8\text{mA}$		0.2	0.4	V
		$I_{OL} = 20\mu\text{A}$		0	0.1	

RS-485 DRIVER ELECTRICAL CHARACTERISTICS

over recommended operating conditions (unless otherwise noted)

PARAMETER		TEST CONDITIONS	MIN	TYP	MAX	UNIT
V_{OD}	Open-circuit differential output voltage	$ V_A - V_B $, See Figure 2	1.5		V_{CC2}	V
$ V_{OD(SS)} $	Steady-state differential output voltage magnitude	See Figure 3 and Figure 7	2.1			V
		See Figure 4 , Common-mode loading with V_{test} from -7V to $+12\text{V}$	2.1			
$ \Delta V_{OD(SS)} $	Change in steady-state differential output voltage between logic states	See Figure 5 and Figure 6 , $R_L = 54\Omega$	-0.2		0.2	V
$V_{OC(SS)}$	Steady-state common-mode output voltage	See Figure 5 and Figure 65 , $R_L = 54\Omega$	2		3	V
$\Delta V_{OC(SS)}$	Change in steady-state common-mode output voltage		-0.2		0.2	
$V_{OC(pp)}$	Peak-to-peak common-mode output voltage		0.5			
$V_{OD(ring)}$	Differential output voltage over and under shoot	See Figure 7 and Figure 10			10%	$V_{OD(pp)}$
I_I	Input current	D, DE at 0V or V_{CC1}	-10		10	μA
$I_{O(OFF)}$	Power-off output current	$V_{CC2} = 0\text{ V}$	See receiver input current			
I_{OZ}	High-impedance output current	DE at 0V				
$I_{OS(P)}$	Peak short-circuit output current	See Figure 9 , DE at V_{CC1}	$V_{OS} = -7\text{V}$ to 12V	-250	250	mA
$I_{OS(SS)}$	Steady-state short-circuit output current		$V_{OS} = 12\text{V}$, D at GND1		135	
			$V_{OS} = -7\text{V}$, D at V_{CC1}	-135		
C_{OD}	Differential output capacitance		See receiver C_{IN}			
CMTI	Common-mode transient immunity	See Figure 20	25			kV/ μs

RS-485 DRIVER SWITCHING CHARACTERISTICS

over operating free-air temperature range (unless otherwise noted)

PARAMETER		TEST CONDITIONS	MIN	TYP	MAX	UNIT
t_{PLH} , t_{PHL}	Prop delay time	$V_{CC1} = 5V \pm 10\%$, $V_{CC2} = 5V \pm 5\%$		23	35	ns
$t_{sk(p)}$	Pulse skew ($ t_{PHL} - t_{PLH} $)			2	5	
t_{PLH} , t_{PHL}	Prop delay time	$V_{CC1} = 3.3V \pm 10\%$, $V_{CC2} = 5V \pm 5\%$		25	40	ns
$t_{sk(p)}$	Pulse skew ($ t_{PHL} - t_{PLH} $)			2	5	
t_r	Differential output signal rise time	See Figure 10		2	3	ns
t_f	Differential output signal fall time			2	3	
t_{pDE}	DE to ISODE prop delay	See Figure 14			30	ns
$t_t(MLH)$, $t_t(MHL)$	Output transition skew	See Figure 11			1	ns
$t_p(AZH)$, $t_p(BZH)$, $t_p(AZL)$, $t_p(BZL)$	Propagation delay, high-impedance-to-active output	See Figure 12 and Figure 13, $C_L = 50\text{pf}$, \overline{RE} at 0 V			80	ns
$t_p(AHZ)$, $t_p(BHZ)$, $t_p(ALZ)$, $t_p(BLZ)$	Propagation delay, active-to-high-impedance output				80	
$ t_p(AZL) - t_p(BZH) $, $ t_p(AZH) - t_p(BZL) $	Enable skew time			0.55	1.5	ns
$t_{(CFB)}$	Time from application of short-circuit to current fold back	See Figure 9		0.5		μs
$t_{(TSD)}$	Time from application of short-circuit to thermal shutdown	See Figure 9, $T_A = 25^\circ\text{C}$	100			μs

RECEIVER ELECTRICAL CHARACTERISTICS

over recommended operating conditions (unless otherwise noted)

PARAMETER		TEST CONDITIONS	MIN	TYP	MAX	UNIT	
$V_{IT(+)}$	Positive-going input threshold voltage	See Figure 16		-80	-10	mV	
$V_{IT(-)}$	Negative-going input threshold voltage		$I_O = 8\text{mA}$	-200	-120		
V_{hys}	Hysteresis voltage ($V_{IT+} - V_{IT-}$)			25			
V_{OH}	High-level output voltage	$V_{CC1} = 3.3V \pm 10\%$ and $V_{CC2} = 5V \pm 5\%$	$V_{ID} = 200\text{mV}$, See Figure 16	$I_{OH} = -8\text{mA}$	$V_{CC1} - 0.4$	3	V
V_{OL}	Low-level output voltage			$I_{OH} = -20\mu\text{A}$	$V_{CC1} - 0.1$	3.3	
V_{OH}	High-level output voltage	$V_{CC1} = 5V \pm 10\%$ and $V_{CC2} = 5V \pm 5\%$	$V_{ID} = -200\text{mV}$, See Figure 16	$I_{OL} = 8\text{mA}$	$V_{CC1} - 0.8$	4.6	V
V_{OL}	Low-level output voltage			$I_{OL} = 20\mu\text{A}$	$V_{CC1} - 0.1$	5	
I_A , I_B	Bus pin input current	$V_I = -7$ or 12V , Other input = 0 V	$V_{CC2} = 4.75\text{V}$ or 5.25V	-160	200	μA	
$I_{A(off)}$, $I_{B(off)}$							$V_{CC2} = 0\text{V}$
I_I	Receiver enable input current	$\overline{RE} = 0\text{V}$		-50	50	μA	
I_{OZ}	High-impedance state output current	$\overline{RE} = V_{CC1}$		-1	1	μA	
R_{ID}	Differential input resistance	A, B		60		k Ω	
C_{ID}	Differential input capacitance	Test input signal is a 1MHz sine wave with 1Vpp amplitude. CD is measured across A and B.		7	10	pF	
CMR	Common mode rejection	See Figure 19		4		V	

RECEIVER SWITCHING CHARACTERISTICS

over recommended operating conditions (unless otherwise noted)

PARAMETER		TEST CONDITIONS	MIN	TYP	MAX	UNIT
t_{PLH} , t_{PHL}	Propagation delay time	See Figure 16		50	65	ns
$t_{sk(p)}$	Pulse skew ($ t_{PHL} - t_{PLH} $)			2	5	
t_{PLH} , t_{PHL}	Propagation delay time			53	70	
$t_{sk(p)}$	Pulse skew ($ t_{PHL} - t_{PLH} $)			2	5	
t_r	Output signal rise time		2	4		
t_f	Output signal fall time		2	4		
t_{PZH}	Propagation delay, high-impedance-to-high-level output	DE at V_{CC1} , See Figure 17		13	25	
t_{PHZ}	Propagation delay, high-level-to-high-impedance output			13	25	
t_{PZL}	Propagation delay, high-impedance-to-low-level output	DE at V_{CC1} , See Figure 18		13	25	
t_{PLZ}	Propagation delay, low-level-to-high-impedance output			13	25	

TRANSFORMER DRIVER CHARACTERISTICS

over operating free-air temperature range (unless otherwise noted)

PARAMETER		TEST CONDITIONS	MIN	TYP	MAX	UNIT
f_{OSC}	Oscillator frequency	$V_{CC1} = 5V \pm 10\%$, D1 and D2 connected to Transformer	350	450	610	kHz
		$V_{CC1} = 3.3V \pm 10\%$, D1 and D2 connected to Transformer	300	400	550	
R_{ON}	Switch on resistance	D1 and D2 connected to 50 Ω pull-up resistors		1	2.5	Ω
$t_{r,D}$	D1, D2 output rise time	$V_{CC1} = 5V \pm 10\%$, See Figure 21 , D1 and D2 connected to 50 Ω pull-up resistors		80		ns
		$V_{CC1} = 3.3V \pm 10\%$, See Figure 21 , D1 and D2 connected to 50 Ω pull-up resistors		70		
$t_{f,D}$	D1, D2 output fall time	$V_{CC1} = 5V \pm 10\%$, See Figure 21 , D1 and D2 connected to 50 Ω pull-up resistors		55		ns
		$V_{CC1} = 3.3V \pm 10\%$, See Figure 21 , D1 and D2 connected to 50 Ω pull-up resistors		80		
f_{St}	Startup frequency	$V_{CC1} = 2.4V$, D1 and D2 connected to Transformer		350		kHz
t_{BBM}	Break before make time delay	$V_{CC1} = 5V \pm 10\%$, See Figure 21 , D1 and D2 connected to 50 Ω pull-up resistors		38		ns
		$V_{CC1} = 3.3V \pm 10\%$, See Figure 21 , D1 and D2 connected to 50 Ω pull-up resistors		140		

PARAMETER MEASUREMENT INFORMATION

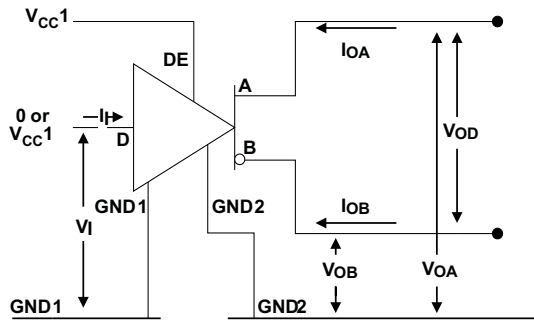

Figure 2. Open Circuit Voltage Test Circuit

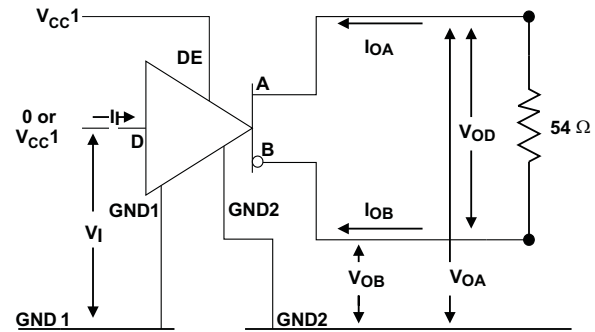

Figure 3. V_{OD} Test Circuit

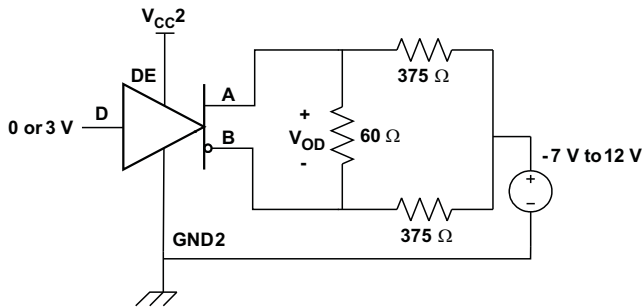

Figure 4. Driver V_{OD} with Common-mode Loading Test Circuit

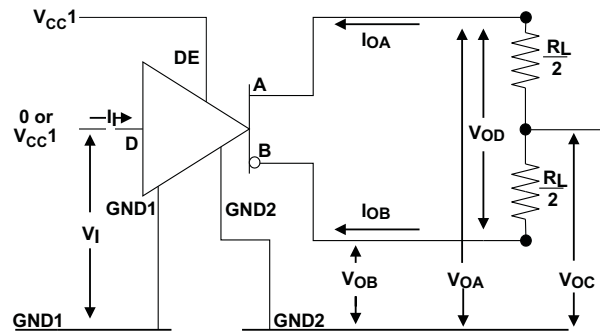

Figure 5. Driver V_{OD} and V_{OC} Without Common-Mode Loading Test Circuit

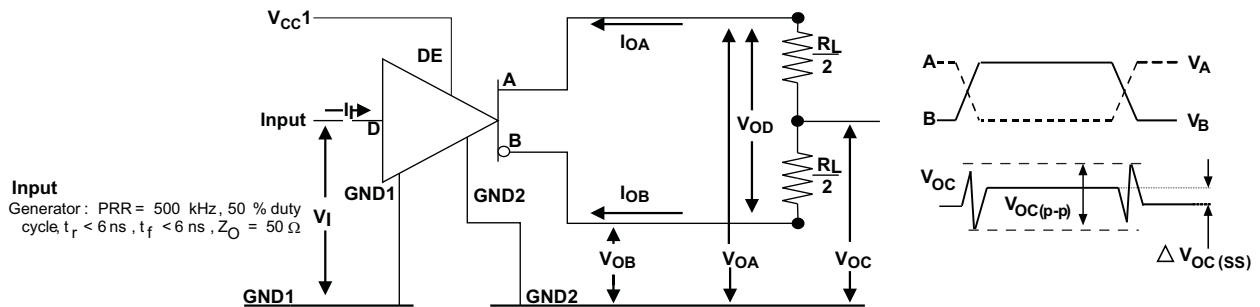

Figure 6. Steady-State Output Voltage Test Circuit and Voltage Waveforms

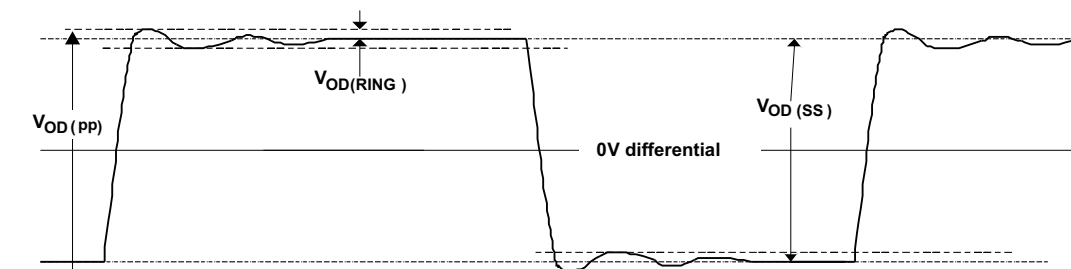

Figure 7. $V_{OD(RING)}$ Waveform and Definitions

PARAMETER MEASUREMENT INFORMATION (continued)

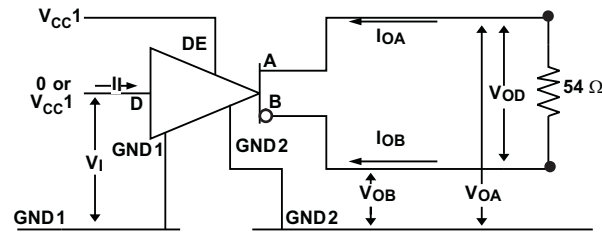

Figure 8. Input Voltage Hysteresis Test Circuit

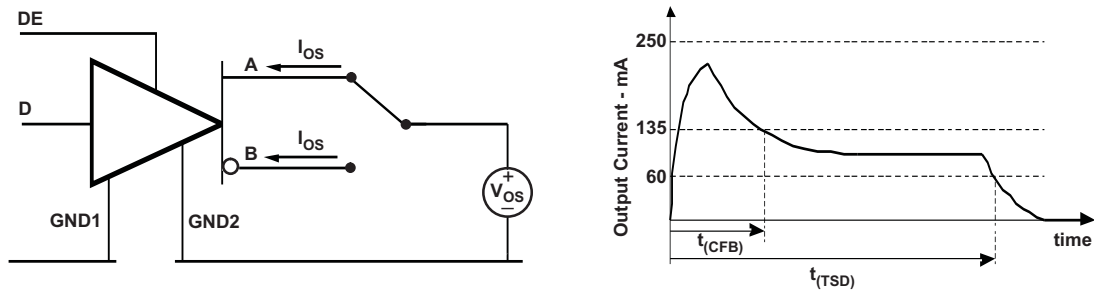

Figure 9. Driver Short-Circuit Test Circuit and Waveforms (Short Circuit applied at Time t=0)

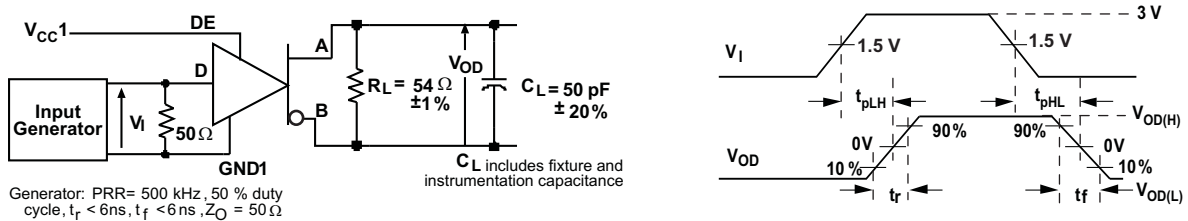

Figure 10. Driver Switching Test Circuit and Waveforms

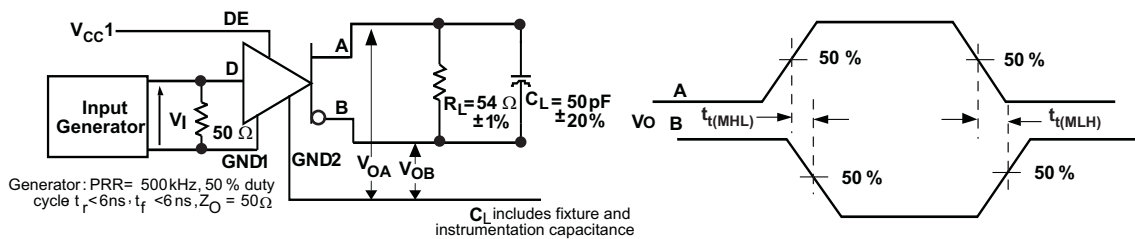

Figure 11. Driver Output Transition Skew Test Circuit and Waveforms

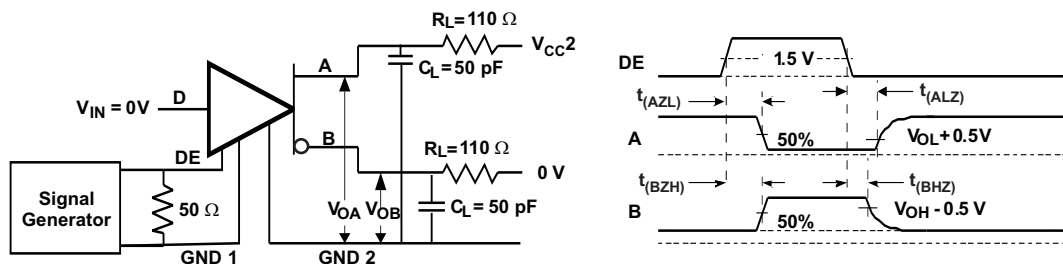

Figure 12. Driver Enable/Disable Test, D at Logic Low Test Circuit and Waveforms

PARAMETER MEASUREMENT INFORMATION (continued)

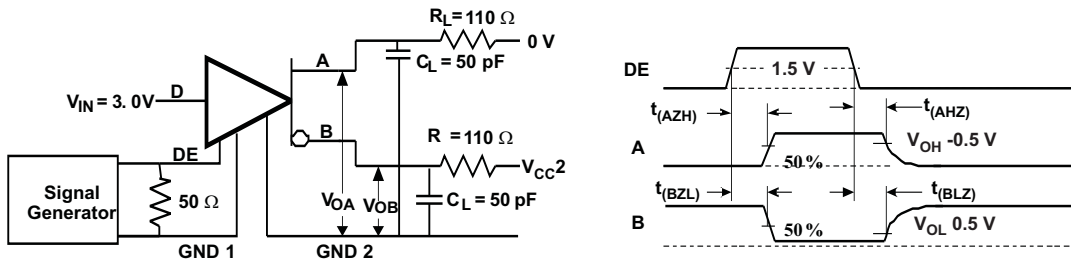

Figure 13. Driver Enable/Disable Test, D at Logic High Test Circuit and Waveforms

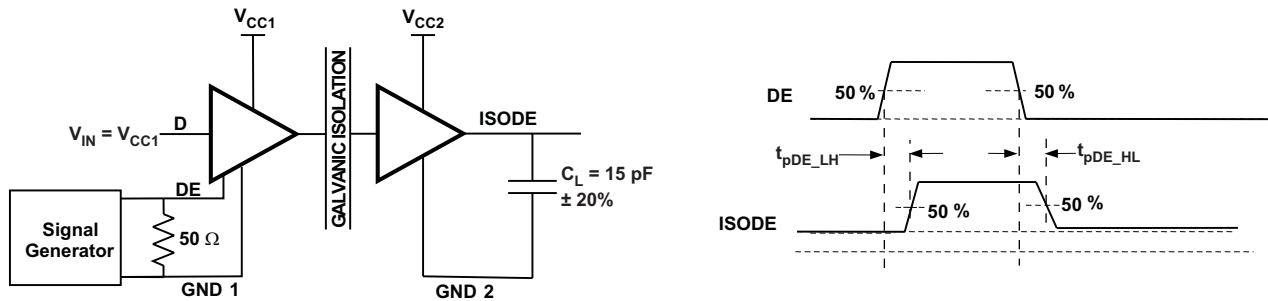

Figure 14. DE to ISODE Prop Delay Test Circuit and Waveforms

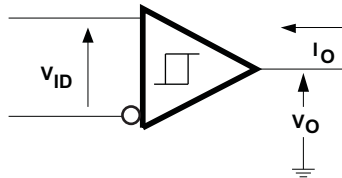

Figure 15. Receiver DC Parameter Definitions

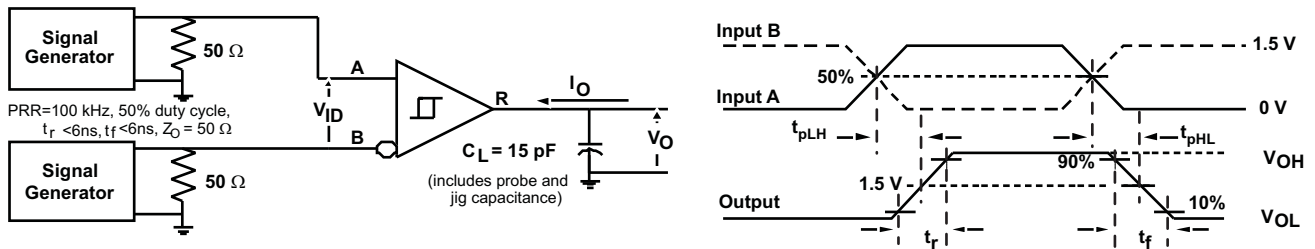

Figure 16. Receiver Switching Test Circuit and Waveforms

PARAMETER MEASUREMENT INFORMATION (continued)

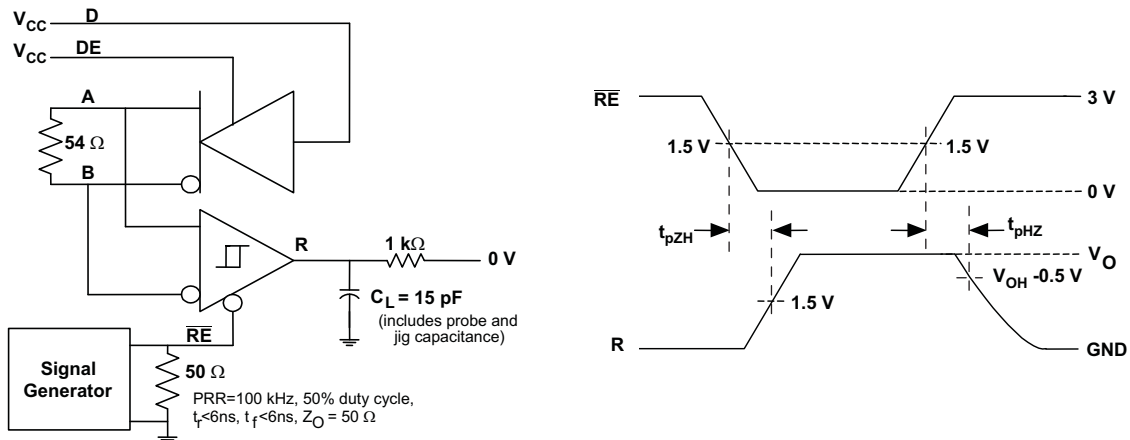

Figure 17. Receiver Enable Test Circuit and Waveforms, Data Output High

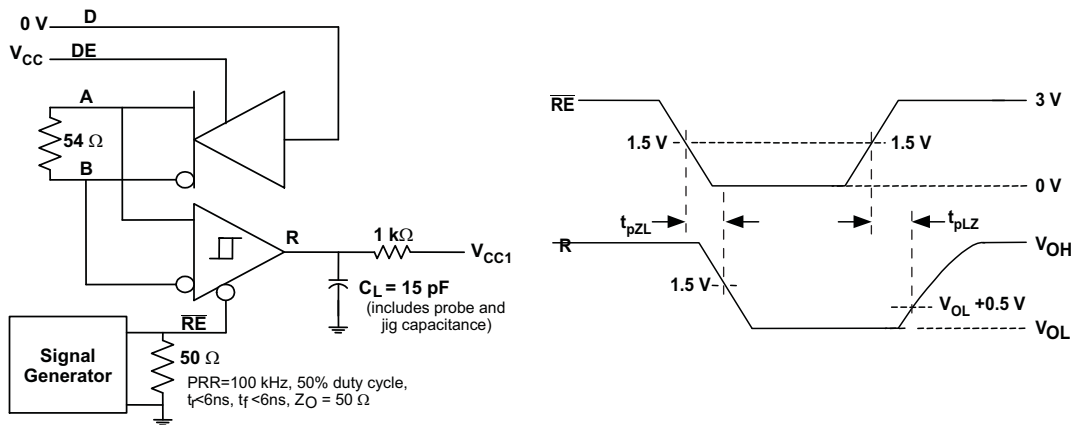

Figure 18. Receiver Enable Test Circuit and Waveforms, Data Output Low

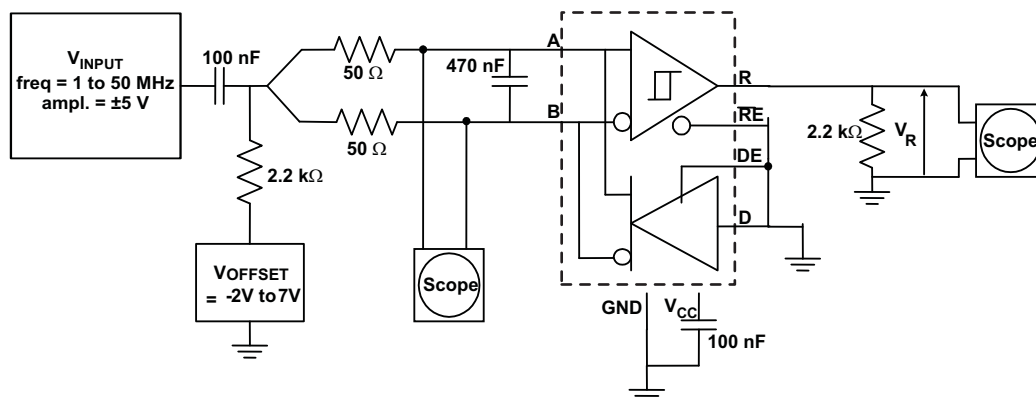

Figure 19. Common-Mode Rejection Test Circuit

Table 1. DRIVER FUNCTION TABLE⁽¹⁾

V _{CC1}	V _{CC2}	INPUT (D)	ENABLE INPUT (DE)	ENABLE OUTPUT (ISODE)	OUTPUTS	
					A	B
PU	PU	H	H	H	H	L
PU	PU	L	H	H	L	H
PU	PU	X	L	L	Z	Z
PU	PU	X	open	L	Z	Z
PU	PU	open	H	H	H	L
PD	PU	X	X	L	Z	Z
PU	PD	X	X	L	Z	Z
PD	PD	X	X	L	Z	Z

(1) PU = Powered Up, PD = Powered Down, H = High Level, L = Low Level, X = Don't Care, Z = High Impedance (off)

Table 2. RECEIVER FUNCTION TABLE⁽¹⁾

V _{CC1}	V _{CC2}	DIFFERENTIAL INPUT V _{ID} = (V _A – V _B)	ENABLE (\overline{RE})	OUTPUT (R)
PU	PU	$-0.01V \leq V_{ID}$	L	H
PU	PU	$-0.2V < V_{ID} < -0.01V$	L	?
PU	PU	$V_{ID} \leq -0.2V$	L	L
PU	PU	X	H	Z
PU	PU	X	open	Z
PU	PU	Open circuit	L	H
PU	PU	Short Circuit	L	H
PU	PU	Idle (terminated) bus	L	H
PD	PU	X	X	Z
PU	PD	X	L	H
PD	PD	X	X	Z

(1) PU = Powered Up, PD = Powered Down, H = High Level, L = Low Level, X = Don't Care, Z = High Impedance (off), ? = Indeterminate

IEC INSULATION AND SAFETY RELATED SPECIFICATIONS FOR 16-DW PACKAGE

over recommended operating conditions (unless otherwise noted)

PARAMETER		TEST CONDITIONS	MIN	TYP	MAX	UNIT
L(I01)	Minimum air gap (Clearance) ⁽¹⁾	Shortest terminal to terminal distance through air	8.3			mm
L(I02)	Minimum external tracking (Creepage) ⁽¹⁾	Shortest terminal to terminal distance across the package surface	8.1			mm
CTI	Tracking resistance (Comparative Tracking Index)	DIN IEC 60112 / VDE 0303 Part 1	400			V
	Minimum Internal Gap (Internal Clearance)	Distance through the insulation	0.008			mm
R _{IO}	Isolation resistance	Input to output, V _{IO} = 500 V, all pins on each side of the barrier tied together creating a two-terminal device		>10 ¹²		Ω
C _{IO}	Barrier capacitance Input to output	V _I = V _{CC} /2 + 0.4 sin(2πft), f = 1MHz, V _{CC} = 5 V		2		pF
C _I	Input capacitance to ground	V _I = 0.4 sin(2πft), f = 1MHz		2		pF
P _D	Maximum device power dissipation	V _{CC1} = 5.5V, V _{CC2} = 5.25V, T _J = 150°C, C _L = 50pf, R _L = 54Ω Input a 20MHz 50% duty cycle square wave			719	mW

- (1) Creepage and clearance requirements should be applied according to the specific equipment isolation standards of an application. Care should be taken to maintain the creepage and clearance distance of a board design to make sure that the mounting pads of the isolator on the printed circuit board do not reduce this distance.

Creepage and clearance on a printed circuit board become equal according to the measurement techniques shown in the Isolation Glossary. Techniques such as inserting grooves and/or ribs on a printed circuit board are used to help increase these specifications

IEC 60664-1 RATINGS TABLE

PARAMETER	TEST CONDITIONS	SPECIFICATION
Basic isolation group	Material group	II
Installation classification	Rated mains voltage ≤ 150V _{rms}	I-IV
	Rated mains voltage ≤ 300V _{rms}	I-III
	Rated mains voltage ≤ 400V _{rms}	I-II

IEC 60747-5-2 INSULATION CHARACTERISTICS⁽¹⁾

over recommended operating conditions (unless otherwise noted)

PARAMETER	TEST CONDITIONS	SPECIFICATION	UNIT
V _{IO RM}	Maximum working insulation voltage	566	V _{peak}
V _{PR}	Input to output test voltage	Method b1, V _{PR} = V _{IO RM} × 1.875, 100% Production test with t = 1s, Partial discharge < 5pC	1062
		Method a, After environmental tests subgroup 1, V _{PR} = V _{IO RM} × 1.6, t = 10s, Partial discharge < 5pC	906
		After Input/Output Safety Test Subgroup 2/3, V _{PR} = V _{IO RM} × 1.2, t = 10s, Partial discharge < 5pC	680
V _{IO TM}	Transient overvoltage	t = 60s (qualification), t = 1s (100% production)	4242
V _{IO SM}	Maximum surge voltage	Tested per IEC 60065 (Qualification Test)	4242
R _S	Insulation resistance	V _{IO} = 500V at T _S = 150°C	> 10 ⁹
	Pollution degree		2

- (1) Climatic Classification 40/125/21

ISO1176T

SLLSE28E –OCTOBER 2010–REVISED AUGUST 2011

www.ti.com

REGULATORY INFORMATION

VDE	UL
Certified according to DIN EN 60747-5-2 (VDE 0884 Part 2)	Recognized under 1577 Component Recognition Program
Basic Insulation Maximum Transient Overvoltage, 4242 V _{PK} Maximum Surge Voltage, 4242 V _{PK} Maximum Working Voltage, 566 V _{PK}	Single / Basic Isolation Voltage, 2500 V _{RMS} ⁽¹⁾
File Number: Pending	File Number: Pending

(1) Production tested $\geq 3000 V_{rms}$ for 1 second in accordance with UL 1577.

IEC SAFETY LIMITING VALUES

Safety limiting intends to prevent potential damage to the isolation barrier upon failure of input or output circuitry. A failure of the IO can allow low resistance to ground or the supply and, without current limiting, dissipate sufficient power to overheat the die and damage the isolation barrier potentially leading to secondary system failures.

PARAMETER	TEST CONDITIONS		MIN	TYP	MAX	UNIT
I _S Safety input, output, or supply current	DW-16	$\theta_{JA} = 76^{\circ}\text{C/W}$, $V_I = 5.5\text{ V}$, $T_J = 170^{\circ}\text{C}$, $T_A = 25^{\circ}\text{C}$			347	mA
T _S Maximum case temperature	DW-16				150	$^{\circ}\text{C}$

The safety-limiting constraint is the absolute maximum junction temperature specified in the absolute maximum ratings table. The power dissipation and junction-to-air thermal impedance of the device installed in the application hardware determines the junction temperature. The assumed junction-to-air thermal resistance in the Thermal Characteristics table is that of a device installed on a High-K Test Board for Leaded Surface Mount Packages. The power is the recommended maximum input voltage times the current. The junction temperature is then the ambient temperature plus the power times the junction-to-air thermal resistance.

THERMAL INFORMATION

THERMAL METRIC ⁽¹⁾		ISO1176T	UNITS
		DW-16	
θ_{JA}	Junction-to-ambient thermal resistance	76	$^{\circ}\text{C/W}$
$\theta_{JC(top)}$	Junction-to-case(top) thermal resistance	37.9	
θ_{JB}	Junction-to-board thermal resistance	44.6	
Ψ_{JT}	Junction-to-top characterization parameter	12.1	
Ψ_{JB}	Junction-to-board characterization parameter	37.9	
$\theta_{JC(bottom)}$	Junction-to-case(bottom) thermal resistance	n/a	

(1) For more information about traditional and new thermal metrics, see the *IC Package Thermal Metrics* application report, [SPRA953](#).

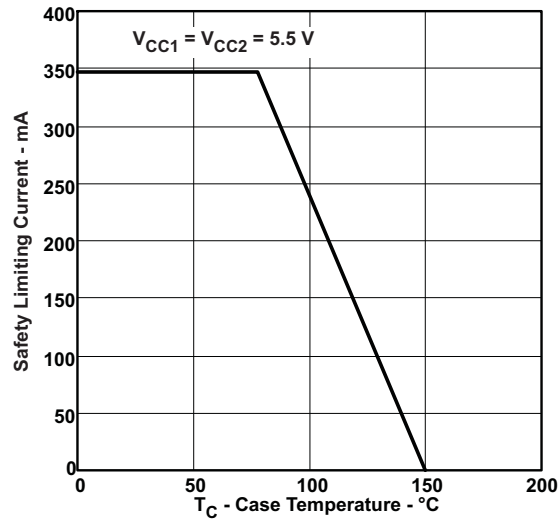
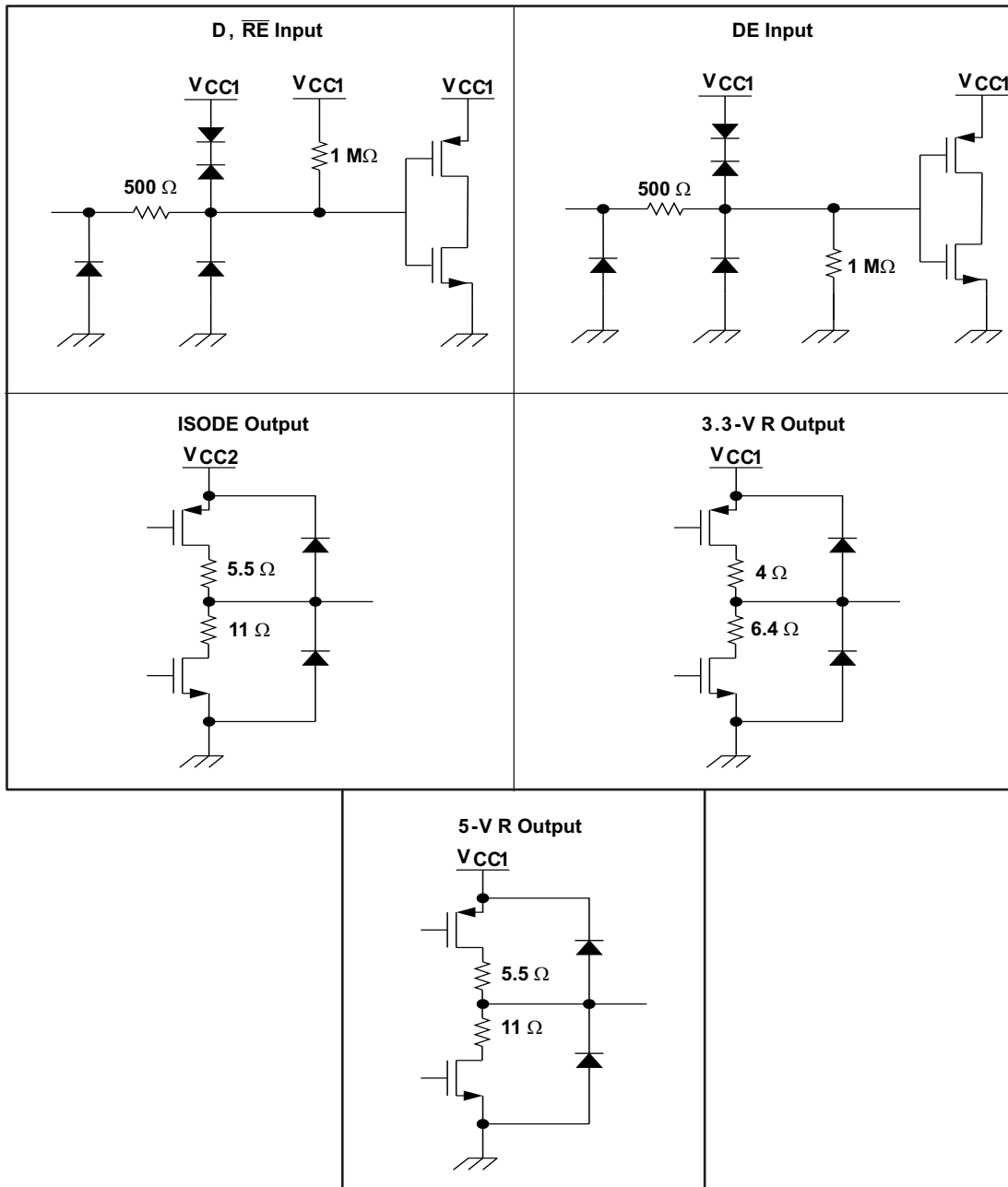
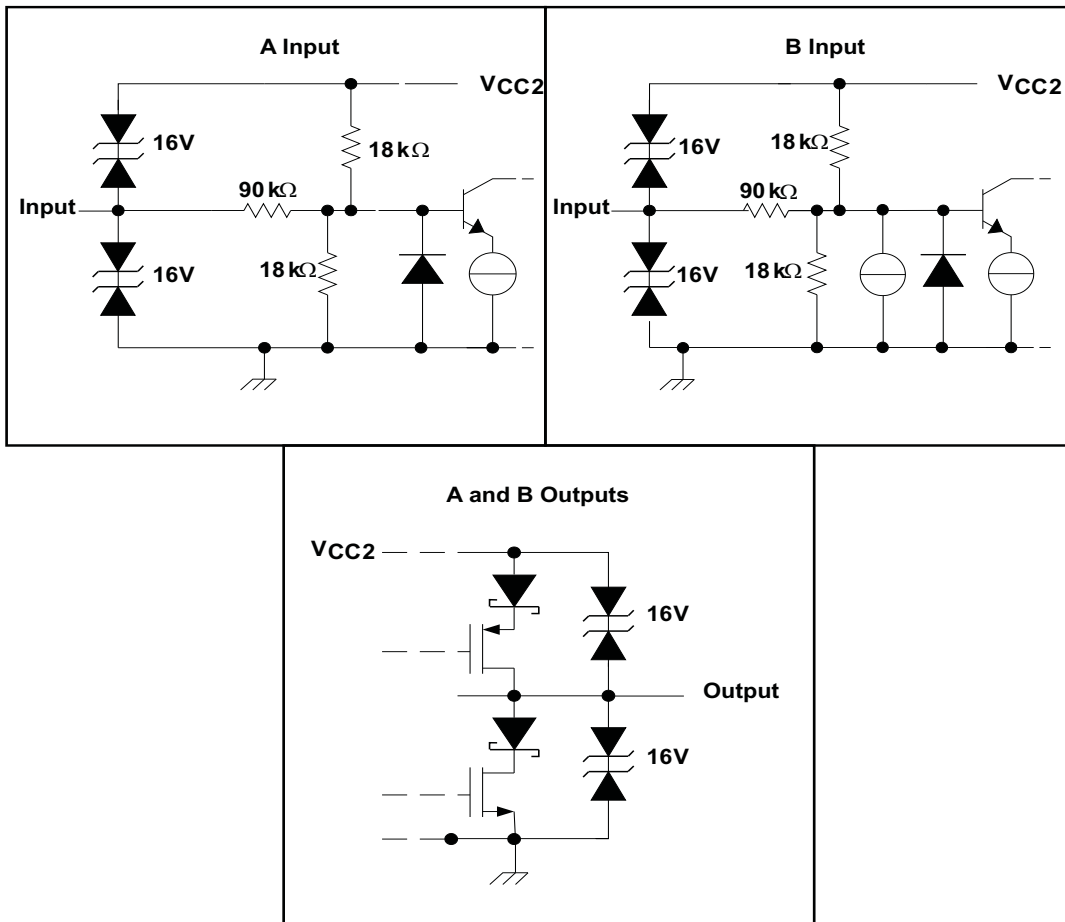

Figure 22. DW-16 θ_{JC} THERMAL DERATING CURVE per IEC 60747-5-2

EQUIVALENT CIRCUIT SCHEMATICS





TYPICAL CHARACTERISTICS

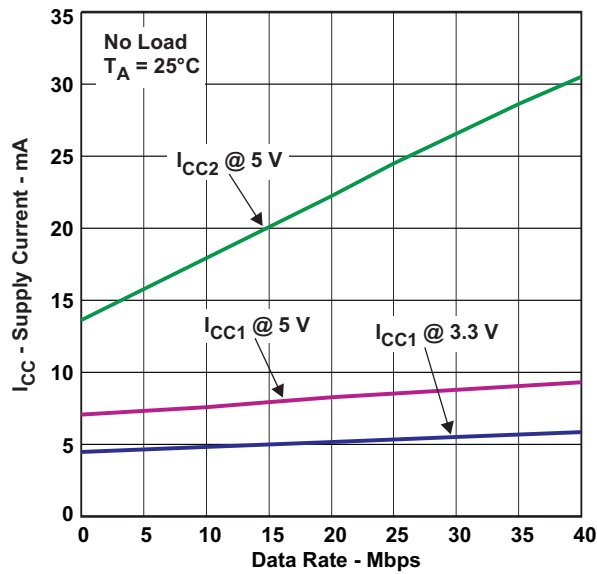

Figure 23. RMS SUPPLY CURRENT (I_{CC1} and I_{CC2}) vs SIGNALING RATE WITH NO LOAD

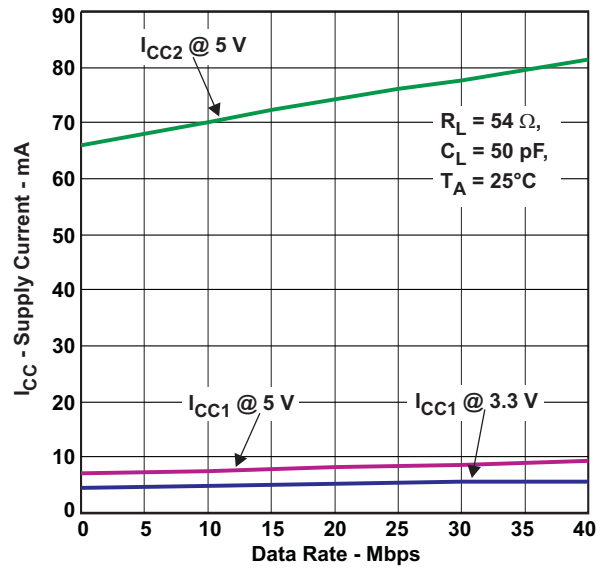

Figure 24. RMS SUPPLY CURRENT (I_{CC1} and I_{CC2}) vs SIGNALING RATE WITH LOAD

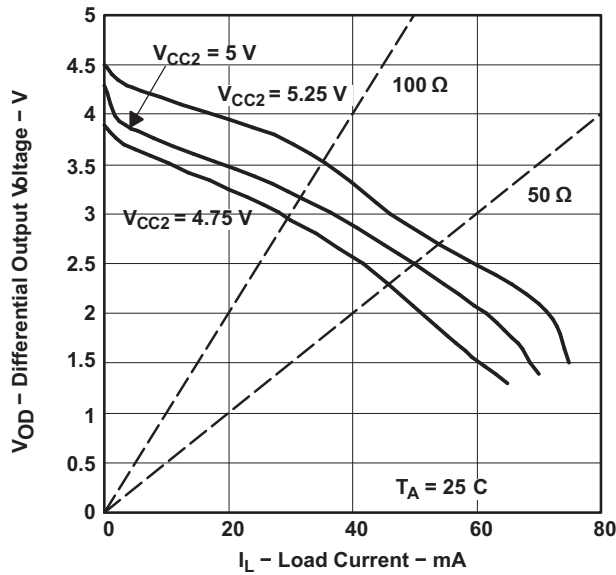

Figure 25. DIFFERENTIAL OUTPUT VOLTAGE vs LOAD CURRENT

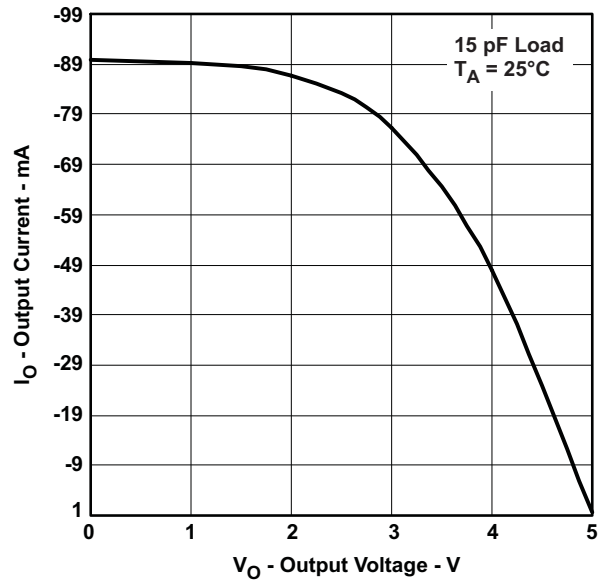

Figure 26. RECEIVER HIGH-LEVEL OUTPUT VOLTAGE vs HIGH-LEVEL OUTPUT CURRENT

TYPICAL CHARACTERISTICS (continued)

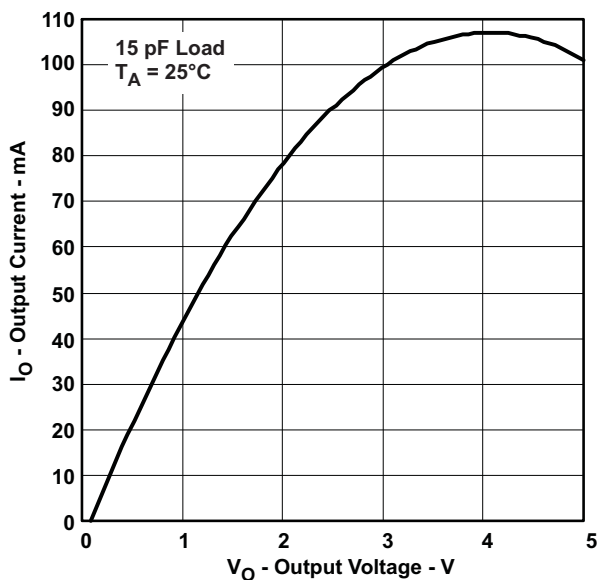

Figure 27. RECEIVER LOW-LEVEL OUTPUT VOLTAGE vs LOW-LEVEL OUTPUT CURRENT

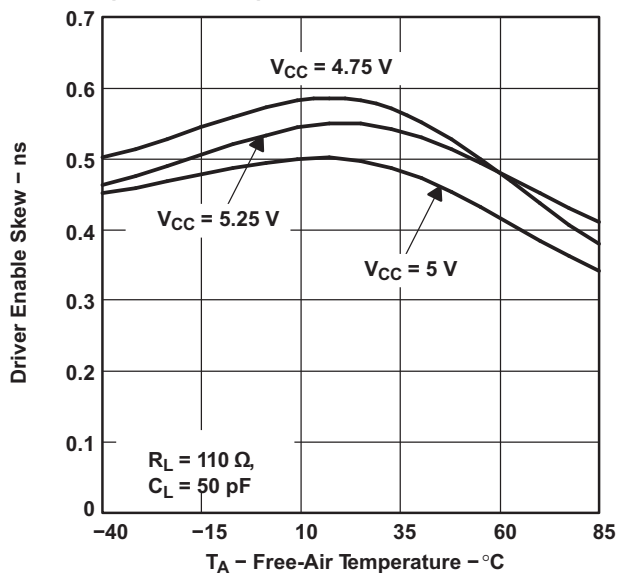

Figure 28. DRIVER ENABLE SKEW vs FREE-AIR TEMPERATURE

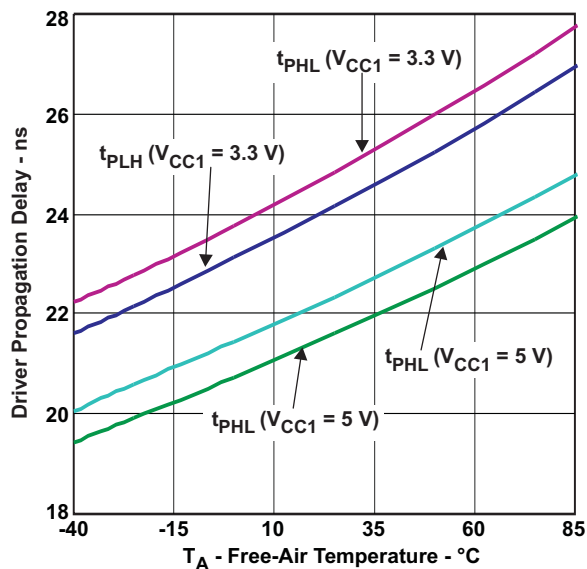

Figure 29. DRIVER PROPAGATION DELAY vs FREE-AIR TEMPERATURE

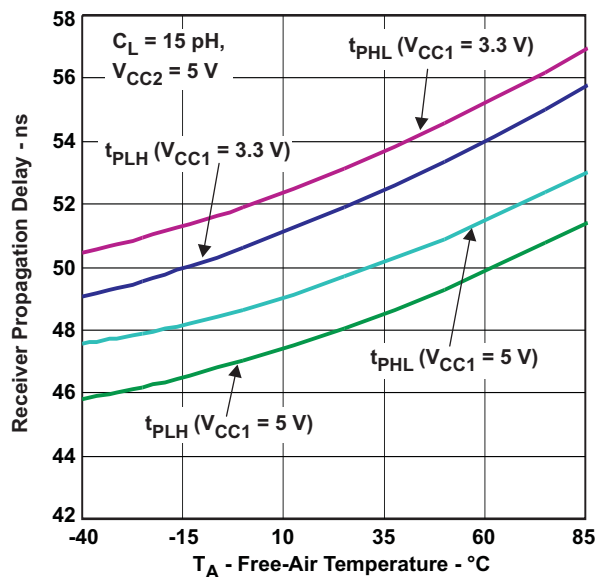

Figure 30. RECEIVER PROPAGATION DELAY vs FREE-AIR TEMPERATURE

APPLICATION INFORMATION

REFERENCE DESIGN

ISO1176T Reference Design (SLLU471) is available to provide complete isolated data and power solution.

TRANSIENT VOLTAGES

Isolation of a circuit insulates it from other circuits and earth so that noise develops across the insulation rather than circuit components. The most common noise threat to data-line circuits is voltage surges or electrical fast transients that occur after installation and the transient ratings of ISO1176T are sufficient for all but the most severe installations. However, some equipment manufacturers use their ESD generators to test transient susceptibility of their equipment and can exceed insulation ratings. ESD generators simulate static discharges that may occur during device or equipment handling with low-energy but high voltage transients.

Figure 31 models the ISO1176T bus IO connected to a noise generator. C_{IN} and R_{IN} is the device and any other stray or added capacitance or resistance across the A or B pin to GND2, C_{ISO} and R_{ISO} is the capacitance and resistance between GND1 and GND2 of ISO1176T plus those of any other insulation (transformer, etc.), and we assume stray inductance negligible. From this model, the voltage at the isolated bus return is

$$V_{GND2} = V_N \frac{Z_{ISO}}{Z_{ISO} + Z_{IN}}$$
 and will always be less than V_N . If ISO1176T is tested as a stand-alone device, $R_{IN} = 6 \times 10^4 \Omega$, $C_{IN} = 16 \times 10^{-12} \text{ F}$, $R_{ISO} = 10^9 \Omega$ and $C_{ISO} = 10^{-12} \text{ F}$.

Note from Figure 31 that the resistor ratio determines the voltage ratio at low frequency and it is the inverse capacitance ratio at high frequency. In the stand-alone case and for low frequency,

$$\frac{V_{GND2}}{V_N} = \frac{R_{ISO}}{R_{ISO} + R_{IN}} = \frac{10^9}{10^9 + 6 \times 10^4}$$

or essentially all of noise appears across the barrier. At high frequency,

$$\frac{V_{GND2}}{V_N} = \frac{\frac{1}{C_{ISO}}}{\frac{1}{C_{ISO}} + \frac{1}{C_{IN}}} = \frac{1}{1 + \frac{C_{ISO}}{C_{IN}}} = \frac{1}{1 + \frac{1}{16}} = 0.94$$

and 94% of V_N appears across the barrier. As long as R_{ISO} is greater than R_{IN} and C_{ISO} is less than C_{IN} , most of transient noise appears across the isolation barrier, as it should.

We recommend the reader not test equipment transient susceptibility with ESD generators or consider product claims of ESD ratings above the barrier transient ratings of an isolated interface. ESD is best managed through recessing or covering connector pins in a conductive connector shell and installer training.

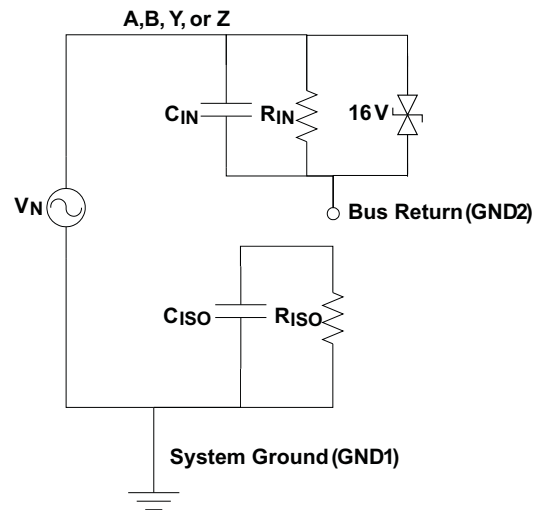

Figure 31. Noise Model

REVISION HISTORY

Changes from Revision initial (October 2010) to Revision A	Page
• Updated transformer driver characteristics	6
• Added Thermal Table data	14
Changes from Revision A (December 2010) to Revision B	Page
• Changed the Steady-state short-circuit output current - Test Conditions and values.	4
• Changed the Oscillator frequency values	6
• Changed the D1, D2 output rise time values	6
Changes from Revision B (December 2010) to Revision C	Page
• Added a Typ value of 23ns to Prop delay time for $V_{CC1} = 5V$ in the RS-485 DRIVER SWITCHING CHARACTERISTIC table	5
• Added a Typ value of 25ns to Prop delay time for $V_{CC1} = 3.3V$ in the RS-485 DRIVER SWITCHING CHARACTERISTIC table	5
• Deleted R_{OFF} from the TRANSFORMER DRIVER CHARACTERISTICS table	6
• Changed $\theta_{JA} = 212^{\circ}C/W$ To: $\theta_{JA} = 76^{\circ}C/W$, Changed the I_S Max value From: 128mA To: 347mA, and changed paragraph two in the IEC SAFETY LIMITING VALUES section	14
• Changed Figure 22	15
Changes from Revision C (February 2011) to Revision D	Page
• Added Figure 1	2
• Moved the Pin Description closer to the Pin drawing	2
Changes from Revision D (May 2011) to Revision E	Page
• Deleted the MIN and MAX values for $t_{r,D}$, $t_{f,D}$ and t_{BDM} specifications in the Transformer Driver Characteristics table.	6
• Changed test conditions from 1.9 V to 2.4 V, and changed TYP value from 230 to 350 for f_{St} specification in the Transformer Driver Characteristics table.	6

PACKAGING INFORMATION

Orderable Device	Status ⁽¹⁾	Package Type	Package Drawing	Pins	Package Qty	Eco Plan ⁽²⁾	Lead/Ball Finish	MSL Peak Temp ⁽³⁾	Samples (Requires Login)
ISO1176TDW	ACTIVE	SOIC	DW	16	40	TBD	Call TI	Call TI	
ISO1176TDWR	ACTIVE	SOIC	DW	16	2000	TBD	Call TI	Call TI	

⁽¹⁾ The marketing status values are defined as follows:

ACTIVE: Product device recommended for new designs.

LIFEBUY: TI has announced that the device will be discontinued, and a lifetime-buy period is in effect.

NRND: Not recommended for new designs. Device is in production to support existing customers, but TI does not recommend using this part in a new design.

PREVIEW: Device has been announced but is not in production. Samples may or may not be available.

OBSELETE: TI has discontinued the production of the device.

⁽²⁾ Eco Plan - The planned eco-friendly classification: Pb-Free (RoHS), Pb-Free (RoHS Exempt), or Green (RoHS & no Sb/Br) - please check <http://www.ti.com/productcontent> for the latest availability information and additional product content details.

TBD: The Pb-Free/Green conversion plan has not been defined.

Pb-Free (RoHS): TI's terms "Lead-Free" or "Pb-Free" mean semiconductor products that are compatible with the current RoHS requirements for all 6 substances, including the requirement that lead not exceed 0.1% by weight in homogeneous materials. Where designed to be soldered at high temperatures, TI Pb-Free products are suitable for use in specified lead-free processes.

Pb-Free (RoHS Exempt): This component has a RoHS exemption for either 1) lead-based flip-chip solder bumps used between the die and package, or 2) lead-based die adhesive used between the die and leadframe. The component is otherwise considered Pb-Free (RoHS compatible) as defined above.

Green (RoHS & no Sb/Br): TI defines "Green" to mean Pb-Free (RoHS compatible), and free of Bromine (Br) and Antimony (Sb) based flame retardants (Br or Sb do not exceed 0.1% by weight in homogeneous material)

⁽³⁾ MSL, Peak Temp. -- The Moisture Sensitivity Level rating according to the JEDEC industry standard classifications, and peak solder temperature.

Important Information and Disclaimer: The information provided on this page represents TI's knowledge and belief as of the date that it is provided. TI bases its knowledge and belief on information provided by third parties, and makes no representation or warranty as to the accuracy of such information. Efforts are underway to better integrate information from third parties. TI has taken and continues to take reasonable steps to provide representative and accurate information but may not have conducted destructive testing or chemical analysis on incoming materials and chemicals. TI and TI suppliers consider certain information to be proprietary, and thus CAS numbers and other limited information may not be available for release.

In no event shall TI's liability arising out of such information exceed the total purchase price of the TI part(s) at issue in this document sold by TI to Customer on an annual basis.

DW (R-PDSO-G16)

PLASTIC SMALL OUTLINE

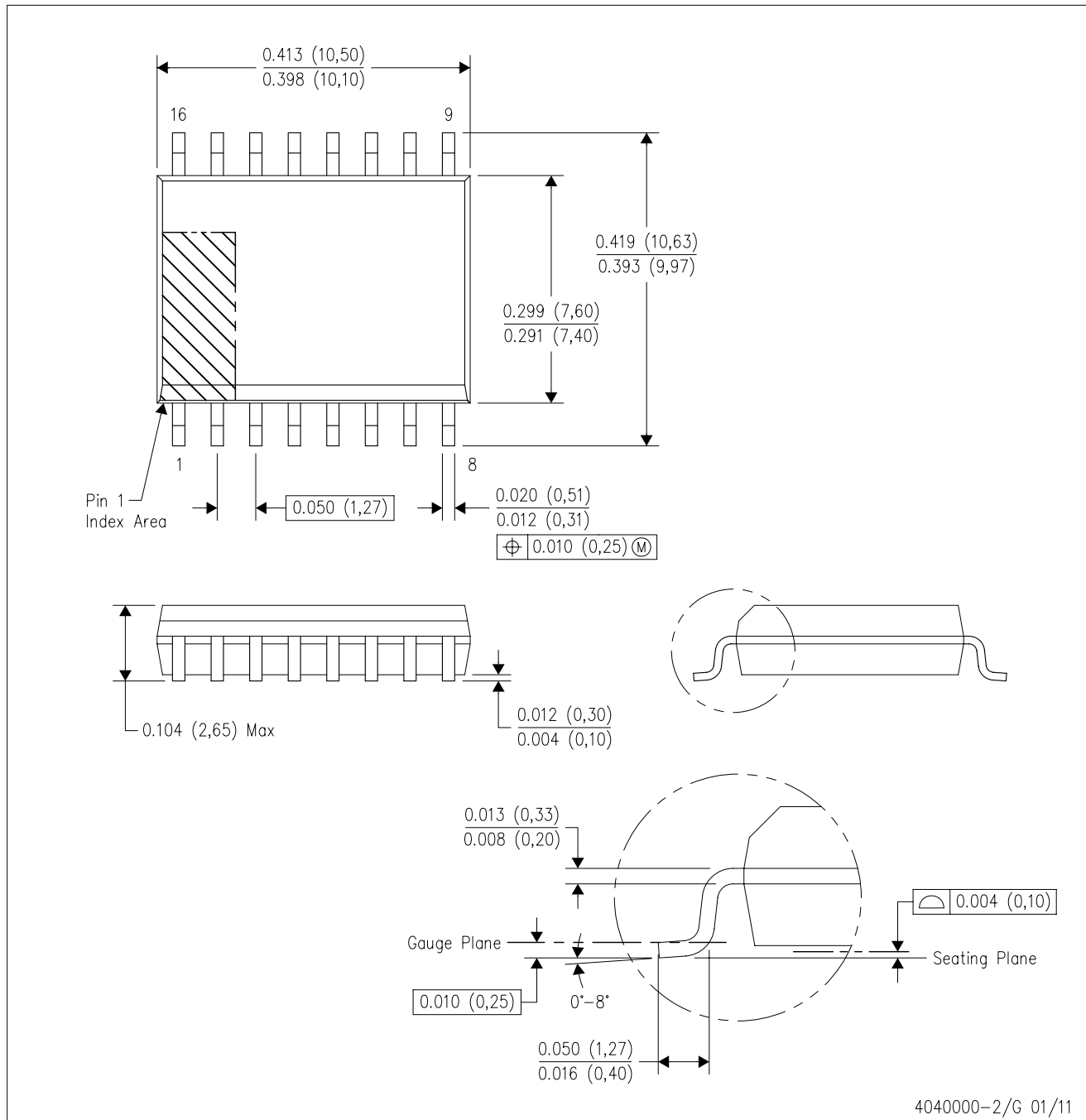

- NOTES:
- All linear dimensions are in inches (millimeters). Dimensioning and tolerancing per ASME Y14.5M-1994.
 - This drawing is subject to change without notice.
 - Body dimensions do not include mold flash or protrusion not to exceed 0.006 (0,15).
 - Falls within JEDEC MS-013 variation AA.

IMPORTANT NOTICE

Texas Instruments Incorporated and its subsidiaries (TI) reserve the right to make corrections, modifications, enhancements, improvements, and other changes to its products and services at any time and to discontinue any product or service without notice. Customers should obtain the latest relevant information before placing orders and should verify that such information is current and complete. All products are sold subject to TI's terms and conditions of sale supplied at the time of order acknowledgment.

TI warrants performance of its hardware products to the specifications applicable at the time of sale in accordance with TI's standard warranty. Testing and other quality control techniques are used to the extent TI deems necessary to support this warranty. Except where mandated by government requirements, testing of all parameters of each product is not necessarily performed.

TI assumes no liability for applications assistance or customer product design. Customers are responsible for their products and applications using TI components. To minimize the risks associated with customer products and applications, customers should provide adequate design and operating safeguards.

TI does not warrant or represent that any license, either express or implied, is granted under any TI patent right, copyright, mask work right, or other TI intellectual property right relating to any combination, machine, or process in which TI products or services are used. Information published by TI regarding third-party products or services does not constitute a license from TI to use such products or services or a warranty or endorsement thereof. Use of such information may require a license from a third party under the patents or other intellectual property of the third party, or a license from TI under the patents or other intellectual property of TI.

Reproduction of TI information in TI data books or data sheets is permissible only if reproduction is without alteration and is accompanied by all associated warranties, conditions, limitations, and notices. Reproduction of this information with alteration is an unfair and deceptive business practice. TI is not responsible or liable for such altered documentation. Information of third parties may be subject to additional restrictions.

Resale of TI products or services with statements different from or beyond the parameters stated by TI for that product or service voids all express and any implied warranties for the associated TI product or service and is an unfair and deceptive business practice. TI is not responsible or liable for any such statements.

TI products are not authorized for use in safety-critical applications (such as life support) where a failure of the TI product would reasonably be expected to cause severe personal injury or death, unless officers of the parties have executed an agreement specifically governing such use. Buyers represent that they have all necessary expertise in the safety and regulatory ramifications of their applications, and acknowledge and agree that they are solely responsible for all legal, regulatory and safety-related requirements concerning their products and any use of TI products in such safety-critical applications, notwithstanding any applications-related information or support that may be provided by TI. Further, Buyers must fully indemnify TI and its representatives against any damages arising out of the use of TI products in such safety-critical applications.

TI products are neither designed nor intended for use in military/aerospace applications or environments unless the TI products are specifically designated by TI as military-grade or "enhanced plastic." Only products designated by TI as military-grade meet military specifications. Buyers acknowledge and agree that any such use of TI products which TI has not designated as military-grade is solely at the Buyer's risk, and that they are solely responsible for compliance with all legal and regulatory requirements in connection with such use.

TI products are neither designed nor intended for use in automotive applications or environments unless the specific TI products are designated by TI as compliant with ISO/TS 16949 requirements. Buyers acknowledge and agree that, if they use any non-designated products in automotive applications, TI will not be responsible for any failure to meet such requirements.

Following are URLs where you can obtain information on other Texas Instruments products and application solutions:

Products

Audio	www.ti.com/audio
Amplifiers	amplifier.ti.com
Data Converters	dataconverter.ti.com
DLP® Products	www.dlp.com
DSP	dsp.ti.com
Clocks and Timers	www.ti.com/clocks
Interface	interface.ti.com
Logic	logic.ti.com
Power Mgmt	power.ti.com
Microcontrollers	microcontroller.ti.com
RFID	www.ti-rfid.com
OMAP Mobile Processors	www.ti.com/omap
Wireless Connectivity	www.ti.com/wirelessconnectivity

Applications

Automotive and Transportation	www.ti.com/automotive
Communications and Telecom	www.ti.com/communications
Computers and Peripherals	www.ti.com/computers
Consumer Electronics	www.ti.com/consumer-apps
Energy and Lighting	www.ti.com/energy
Industrial	www.ti.com/industrial
Medical	www.ti.com/medical
Security	www.ti.com/security
Space, Avionics and Defense	www.ti.com/space-avionics-defense
Video and Imaging	www.ti.com/video

TI E2E Community Home Page

e2e.ti.com

Mailing Address: Texas Instruments, Post Office Box 655303, Dallas, Texas 75265
Copyright © 2012, Texas Instruments Incorporated