

Micro-Power (50µA), Zero-Drift, Rail-to-Rail Out Instrumentation Amplifier

FEATURES

- **LOW OFFSET VOLTAGE:** 25µV (max), $G \geq 100$
- **LOW DRIFT:** 0.1µV/°C, $G \geq 100$
- **LOW NOISE:** 50nV/√Hz, $G \geq 100$
- **HIGH CMRR:** 100dB (min), $G \geq 10$
- **LOW INPUT BIAS CURRENT:** 200pA (max)
- **SUPPLY RANGE:** +1.8V to +5.5V
- **INPUT VOLTAGE:** (V–) +0.1V to (V+) –0.1V
- **OUTPUT RANGE:** (V–) +0.05V to (V+) –0.05V
- **LOW QUIESCENT CURRENT:** 50µA
- **OPERATING TEMPERATURE:** –40°C to +125°C
- **RFI FILTERED INPUTS**
- **MSOP-8 AND DFN-8 PACKAGES**

APPLICATIONS

- BRIDGE AMPLIFIERS
- ECG AMPLIFIERS
- PRESSURE SENSORS
- MEDICAL INSTRUMENTATION
- PORTABLE INSTRUMENTATION
- WEIGH SCALES
- THERMOCOUPLE AMPLIFIERS
- RTD SENSOR AMPLIFIERS
- DATA ACQUISITION

DESCRIPTION

The INA333 is a low-power, precision instrumentation amplifier offering excellent accuracy. The versatile 3-op amp design, small size, and low power make it ideal for a wide range of portable applications.

A single external resistor sets any gain from 1 to 1000. The INA333 is designed to use an industry-standard gain equation: $G = 1 + (100\text{k}\Omega/R_G)$.

The INA333 provides very low offset voltage (25µV, $G \geq 100$), excellent offset voltage drift (0.1µV/°C, $G \geq 100$), and high common-mode rejection (100dB at $G \geq 10$). It operates with power supplies as low as 1.8V (±0.9V), and quiescent current is only 50µA—ideal for battery-operated systems. Using autocalibration techniques to ensure excellent precision over the extended industrial temperature range, the INA333 also offers exceptionally low noise density (50nV/√Hz) that extends down to dc.

The INA333 is available in both MSOP-8 and DFN-8 surface-mount packages and is specified over the $T_A = -40^\circ\text{C}$ to $+125^\circ\text{C}$ temperature range.

Sample Request
[Click Here](#)

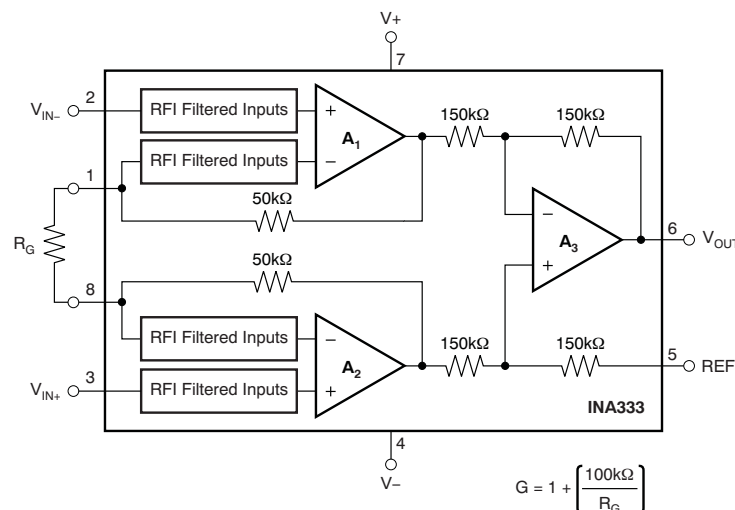

Please be aware that an important notice concerning availability, standard warranty, and use in critical applications of Texas Instruments semiconductor products and disclaimers thereto appears at the end of this data sheet.

All trademarks are the property of their respective owners.



This integrated circuit can be damaged by ESD. Texas Instruments recommends that all integrated circuits be handled with appropriate precautions. Failure to observe proper handling and installation procedures can cause damage.

ESD damage can range from subtle performance degradation to complete device failure. Precision integrated circuits may be more susceptible to damage because very small parametric changes could cause the device not to meet its published specifications.

PACKAGE/ORDERING INFORMATION⁽¹⁾

PRODUCT	PACKAGE-LEAD	PACKAGE DESIGNATOR	PACKAGE MARKING
INA333	MSOP-8	DGK	I333
	DFN-8	DRG	I333A

(1) For the most current package and ordering information see the Package Option Addendum at the end of this document, or see the TI web site at www.ti.com.

ABSOLUTE MAXIMUM RATINGS⁽¹⁾

	INA333	UNIT
Supply voltage	+7	V
Analog input voltage range ⁽²⁾	(V ₋) – 0.3 to (V ₊) + 0.3	V
Output short-circuit ⁽³⁾	Continuous	
Operating temperature range, T _A	–40 to +150	°C
Storage temperature range, T _A	–65 to +150	°C
Junction temperature, T _J	+150	°C
ESD rating	Human body model (HBM)	4000
	Charged device model (CDM)	1000
	Machine model (MM)	200

- (1) Stresses above these ratings may cause permanent damage. Exposure to absolute maximum conditions for extended periods may degrade device reliability. These are stress ratings only, and functional operation of the device at these or any other conditions beyond those specified is not implied.
- (2) Input terminals are diode-clamped to the power-supply rails. Input signals that can swing more than 0.3V beyond the supply rails should be current limited to 10mA or less.
- (3) Short-circuit to ground.

PIN CONFIGURATIONS

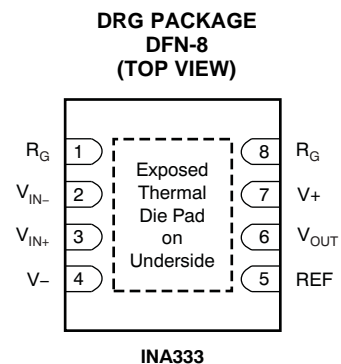
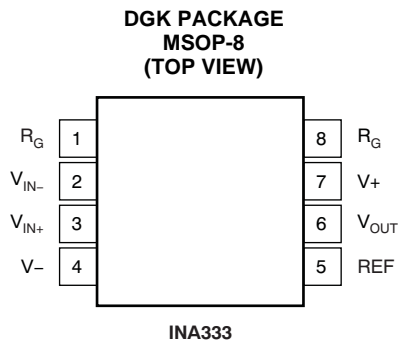

ELECTRICAL CHARACTERISTICS: $V_S = +1.8V$ to $+5.5V$
Boldface limits apply over the specified temperature range, $T_A = -40^{\circ}C$ to $+125^{\circ}C$.

 At $T_A = +25^{\circ}C$, $R_L = 10k\Omega$, $V_{REF} = V_S/2$, and $G = 1$, unless otherwise noted.

PARAMETER	TEST CONDITIONS	INA333			UNIT
		MIN	TYP	MAX	
INPUT⁽¹⁾					
Offset voltage, RTI ⁽²⁾ vs Temperature	V_{OSI}		$\pm 10 \pm 25/G$	$\pm 25 \pm 75/G$	μV
vs Power supply	PSR		$\pm 1 \pm 5/G$	$\pm 0.1 \pm 0.5/G$	$\mu V/^{\circ}C$
Long-term stability			See note ⁽³⁾	$\pm 5 \pm 15/G$	$\mu V/V$
Turn-on time to specified V_{OSI}			See Typical characteristics		
Impedance					
Differential	Z_{IN}		$100 \parallel 3$		$G\Omega \parallel pF$
Common-mode	Z_{IN}		$100 \parallel 3$		$G\Omega \parallel pF$
Common-mode voltage range	V_{CM}	$(V-) + 0.1$		$(V+) - 0.1$	V
Common-mode rejection	CMR				
$G = 1$	$V_O = 0V$ DC to 60Hz $V_{CM} = (V-) + 0.1V$ to $(V+) - 0.1V$	80	90		dB
$G = 10$	$V_{CM} = (V-) + 0.1V$ to $(V+) - 0.1V$	100	110		dB
$G = 100$	$V_{CM} = (V-) + 0.1V$ to $(V+) - 0.1V$	100	115		dB
$G = 1000$	$V_{CM} = (V-) + 0.1V$ to $(V+) - 0.1V$	100	115		dB
INPUT BIAS CURRENT					
Input bias current vs Temperature	I_B		± 70	± 200	pA
Input offset current vs Temperature	I_{OS}		See Typical Characteristic curve		pA^{°C}
			± 50	± 200	pA
			See Typical Characteristic curve		pA^{°C}
INPUT VOLTAGE NOISE					
Input voltage noise	e_{NI}	$G = 100, R_S = 0\Omega$			
$f = 10Hz$			50		nV/\sqrt{Hz}
$f = 100Hz$			50		nV/\sqrt{Hz}
$f = 1kHz$			50		nV/\sqrt{Hz}
$f = 0.1Hz$ to $10Hz$			1		μV_{PP}
Input current noise	i_N				
$f = 10Hz$			100		fA/\sqrt{Hz}
$f = 0.1Hz$ to $10Hz$			2		pA_{PP}
GAIN					
Gain equation	G		$1 + (100k\Omega/R_G)$		V/V
Range of gain			1	1000	V/V
Gain error		$V_S = 5.5V, (V-) + 100mV \leq V_O \leq (V+) - 100mV$			
$G = 1$			± 0.01	± 0.1	%
$G = 10$			± 0.05	± 0.25	%
$G = 100$			± 0.07	± 0.25	%
$G = 1000$			± 0.25	± 0.5	%

 (1) Total V_{OS} , Referred-to-input = $(V_{OSI}) + (V_{OSO}/G)$.

(2) RTI = Referred-to-input.

 (3) 300-hour life test at $+150^{\circ}C$ demonstrated randomly distributed variation of approximately $1\mu V$.

ELECTRICAL CHARACTERISTICS: $V_S = +1.8V$ to $+5.5V$ (continued)

Boldface limits apply over the specified temperature range, $T_A = -40^\circ\text{C}$ to $+125^\circ\text{C}$.

At $T_A = +25^\circ\text{C}$, $R_L = 10\text{k}\Omega$, $V_{REF} = V_S/2$, and $G = 1$, unless otherwise noted.

PARAMETER	TEST CONDITIONS	INA333			UNIT
		MIN	TYP	MAX	
GAIN (continued)					
Gain vs Temperature					
G = 1			± 1	± 5	ppm/°C
G > 1⁽⁴⁾			± 15	± 50	ppm/°C
Gain nonlinearity	$V_S = 5.5V$, $(V_-) + 100\text{mV} \leq V_O \leq (V_+) - 100\text{mV}$				
G = 1 to 1000	$R_L = 10\text{k}\Omega$		10		ppm
OUTPUT					
Output voltage swing from rail ⁽⁵⁾	$V_S = 5.5V$, $R_L = 10\text{k}\Omega$		See note ⁽⁵⁾	50	mV
Capacitive load drive			500		pF
Short-circuit current	I_{SC} Continuous to common		-40, +5		mA
FREQUENCY RESPONSE					
Bandwidth, -3dB					
G = 1			150		kHz
G = 10			35		kHz
G = 100			3.5		kHz
G = 1000			350		Hz
Slew rate	SR				
G = 1	$V_S = 5V$, $V_O = 4V$ Step		0.16		V/ μs
G = 100			0.05		V/ μs
Settling time to 0.01%	t_S				
G = 1	$V_{STEP} = 4V$		50		μs
G = 100	$V_{STEP} = 4V$		400		μs
Settling time to 0.001%	t_S				
G = 1	$V_{STEP} = 4V$		60		μs
G = 100	$V_{STEP} = 4V$		500		μs
Overload recovery	50% overdrive		75		μs
REFERENCE INPUT					
R_{IN}			300		k Ω
Voltage range		V-		V+	V
POWER SUPPLY					
Voltage range					
Single		+1.8		+5.5	V
Dual		± 0.9		± 2.75	V
Quiescent current	I_Q $V_{IN} = V_S/2$		50	75	μA
vs Temperature				80	μA
TEMPERATURE RANGE					
Specified temperature range		-40		+125	°C
Operating temperature range		-40		+150	°C
Thermal resistance	θ_{JA}				
MSOP			100		°C/W
DFN			65		°C/W

(4) Does not include effects of external resistor R_G .

(5) See Typical Characteristics curve, *Output Voltage Swing vs Output Current* (Figure 29).

TYPICAL CHARACTERISTICS

At $T_A = +25^\circ\text{C}$, $V_S = 5\text{V}$, $R_L = 10\text{k}\Omega$, $V_{\text{REF}} = \text{midsupply}$, and $G = 1$, unless otherwise noted.

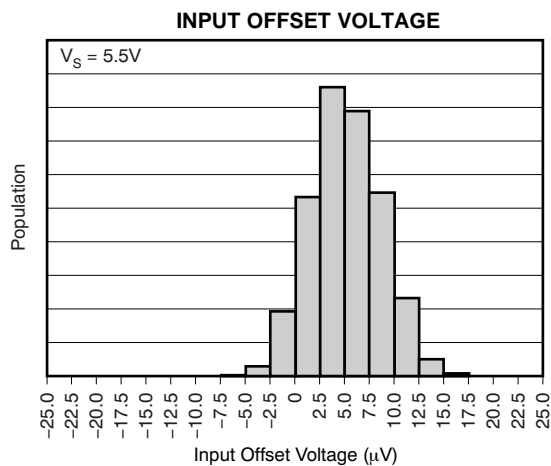

Figure 1.

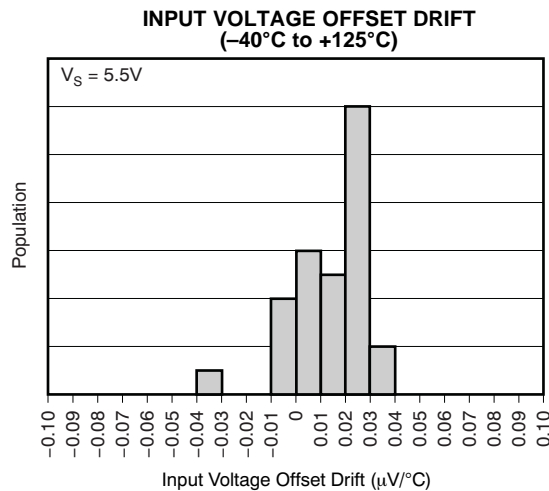

Figure 2.

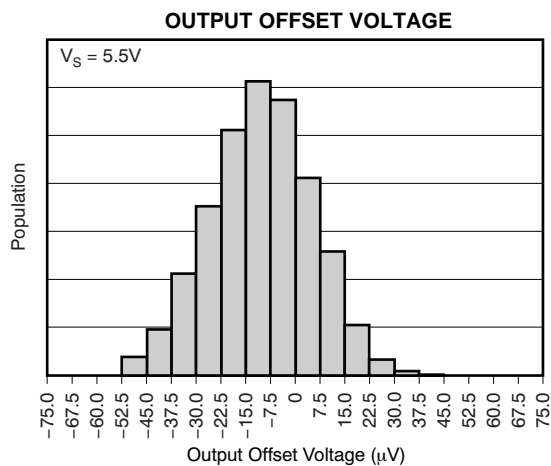

Figure 3.

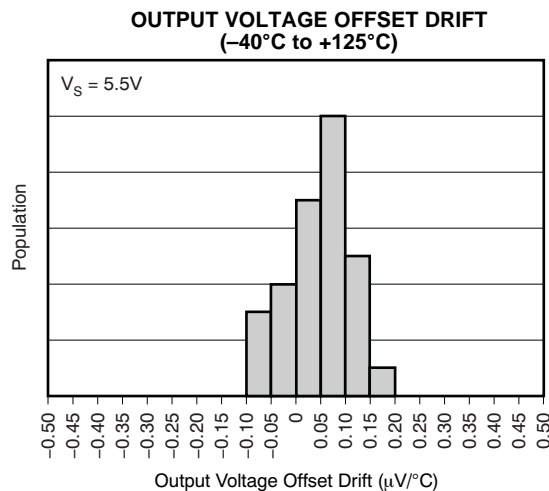

Figure 4.

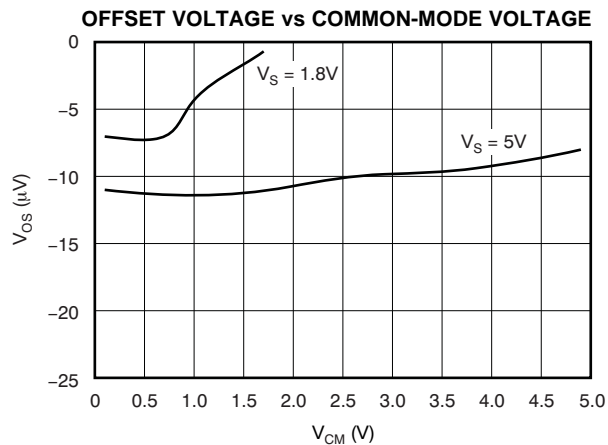

Figure 5.

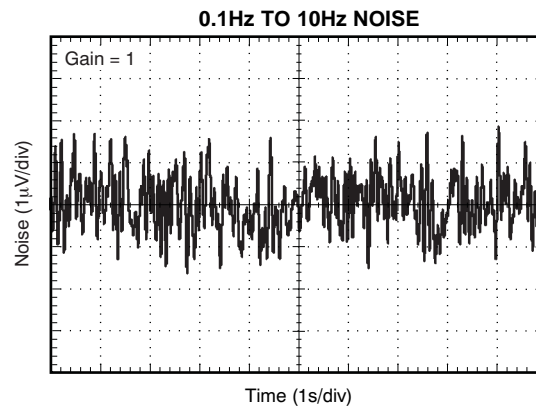

Figure 6.

TYPICAL CHARACTERISTICS (continued)

At $T_A = +25^\circ\text{C}$, $V_S = 5\text{V}$, $R_L = 10\text{k}\Omega$, $V_{REF} = \text{midsupply}$, and $G = 1$, unless otherwise noted.

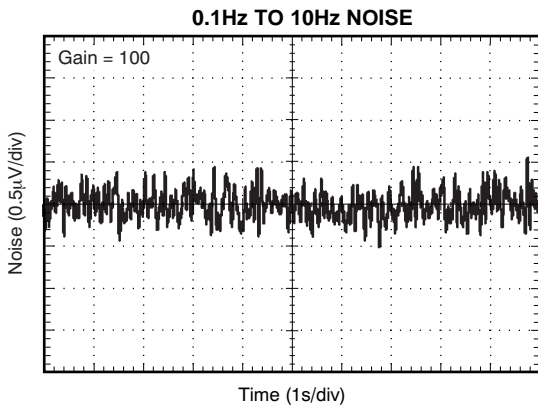

Figure 7.

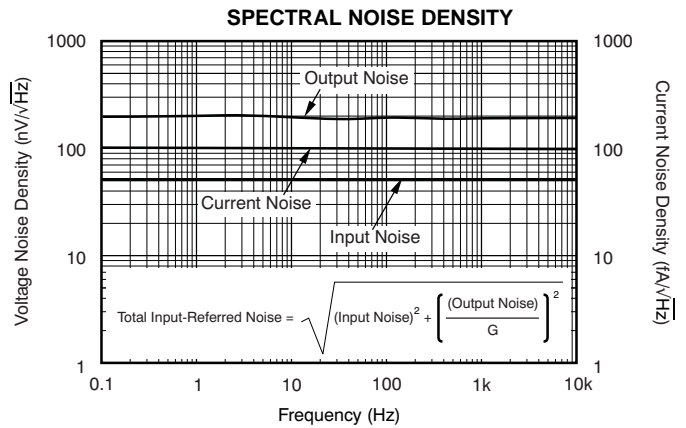

Figure 8.

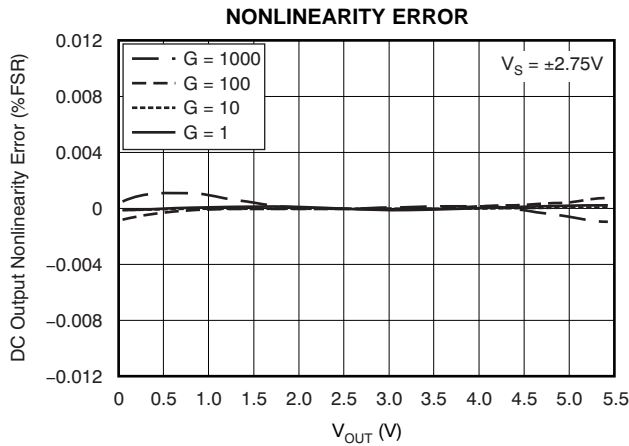

Figure 9.

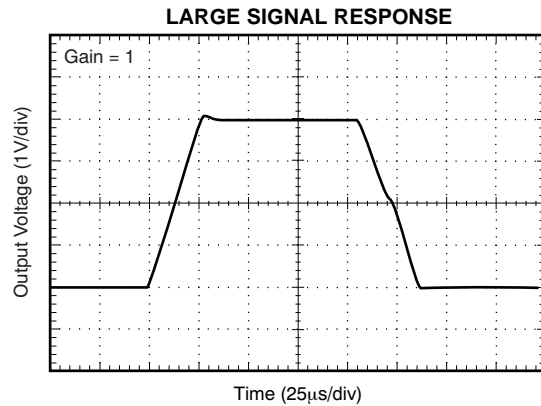

Figure 10.

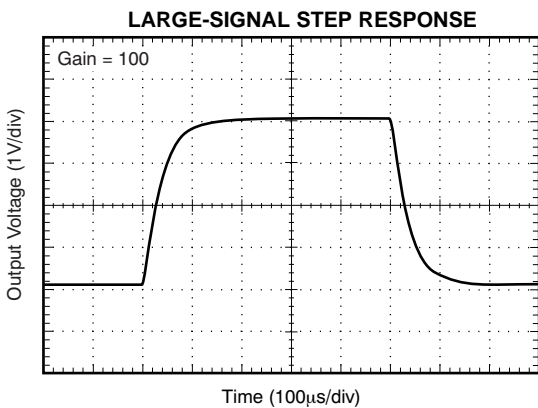

Figure 11.

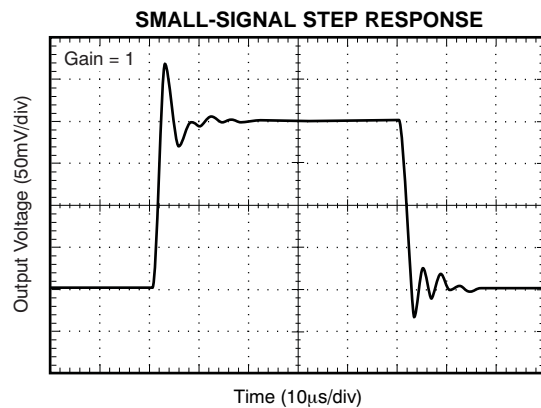

Figure 12.

TYPICAL CHARACTERISTICS (continued)

At $T_A = +25^\circ\text{C}$, $V_S = 5\text{V}$, $R_L = 10\text{k}\Omega$, $V_{REF} = \text{midsupply}$, and $G = 1$, unless otherwise noted.

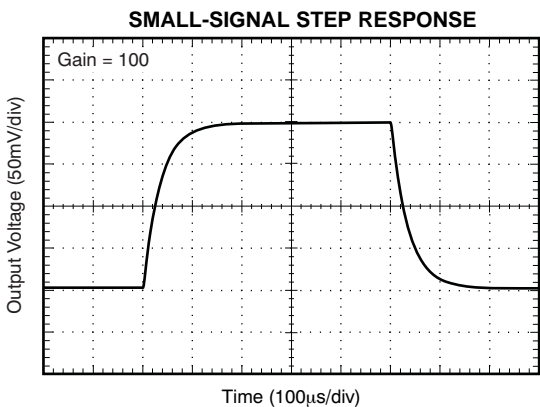

Figure 13.

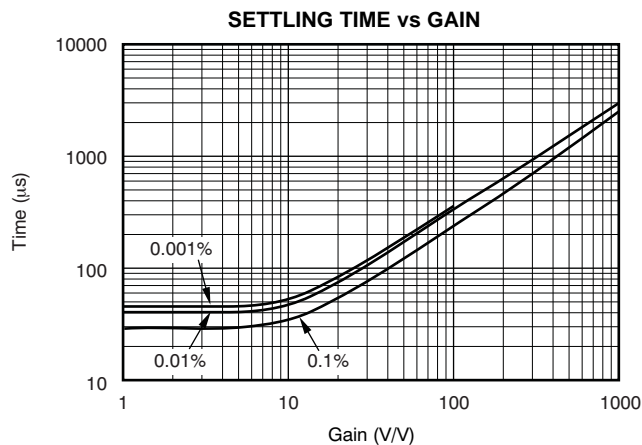

Figure 14.

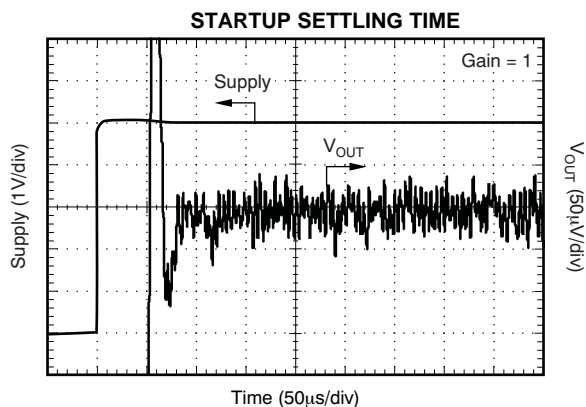

Figure 15.

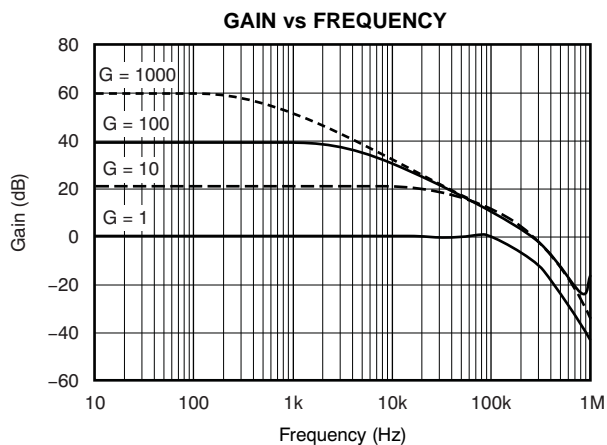

Figure 16.

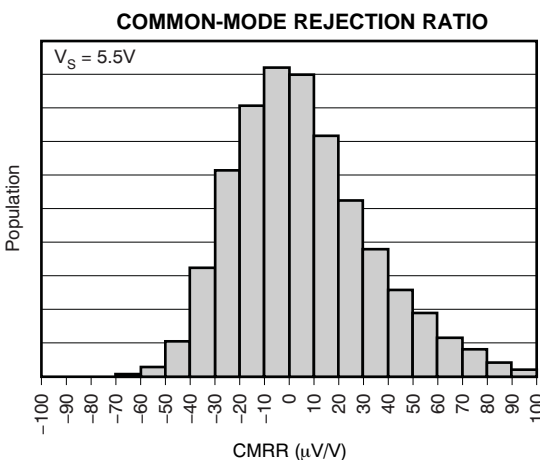

Figure 17.

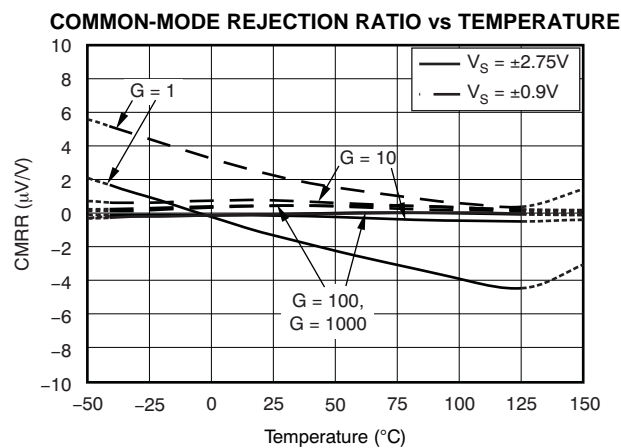

Figure 18.

TYPICAL CHARACTERISTICS (continued)

At $T_A = +25^\circ\text{C}$, $V_S = 5\text{V}$, $R_L = 10\text{k}\Omega$, $V_{REF} = \text{midsupply}$, and $G = 1$, unless otherwise noted.

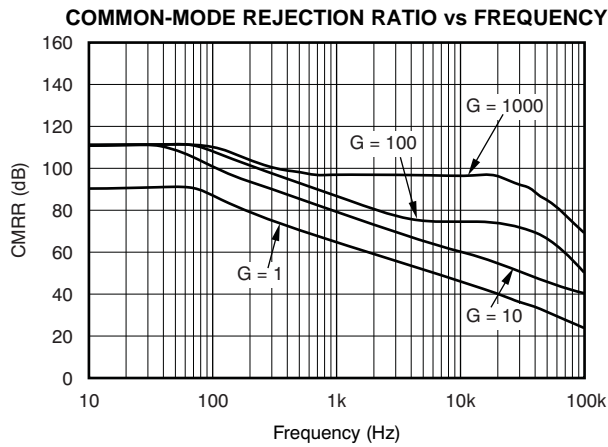

Figure 19.

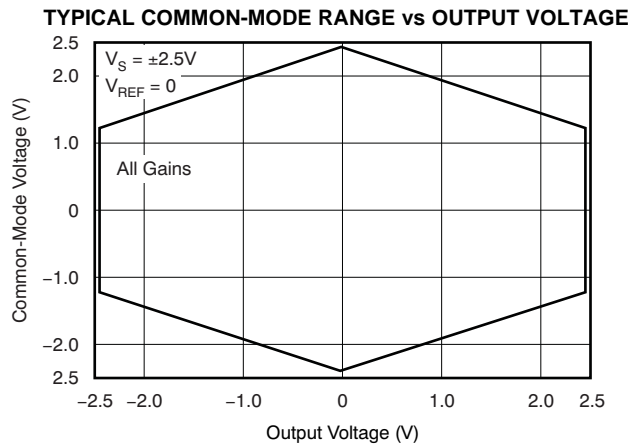

Figure 20.

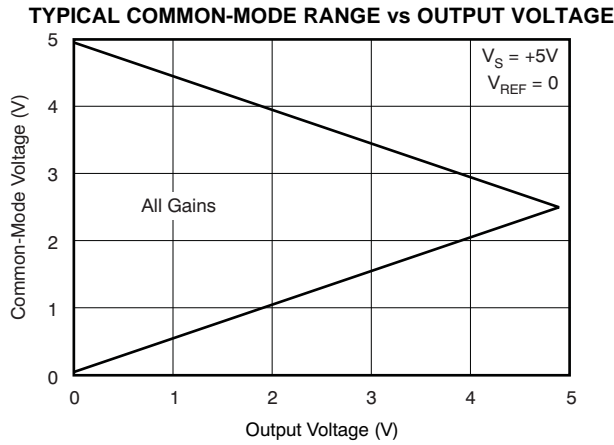

Figure 21.

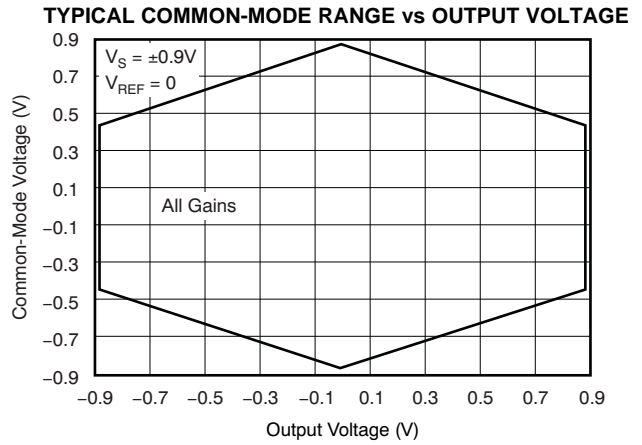

Figure 22.

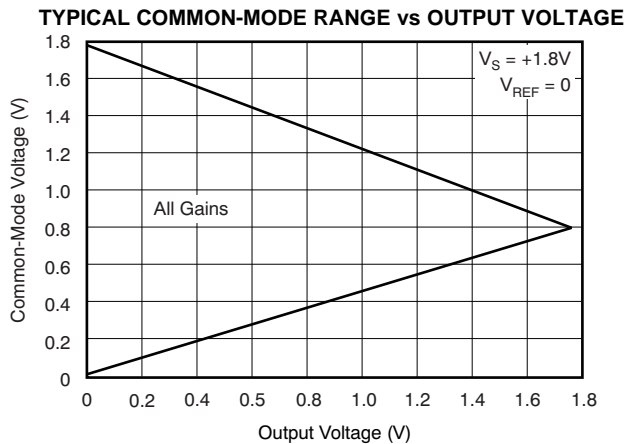

Figure 23.

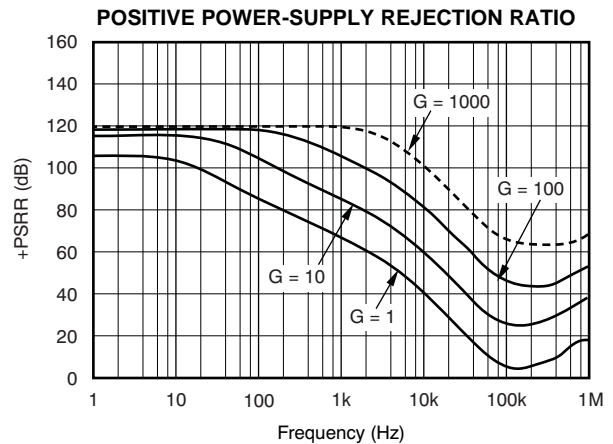

Figure 24.

TYPICAL CHARACTERISTICS (continued)

At $T_A = +25^\circ\text{C}$, $V_S = 5\text{V}$, $R_L = 10\text{k}\Omega$, $V_{\text{REF}} = \text{midsupply}$, and $G = 1$, unless otherwise noted.

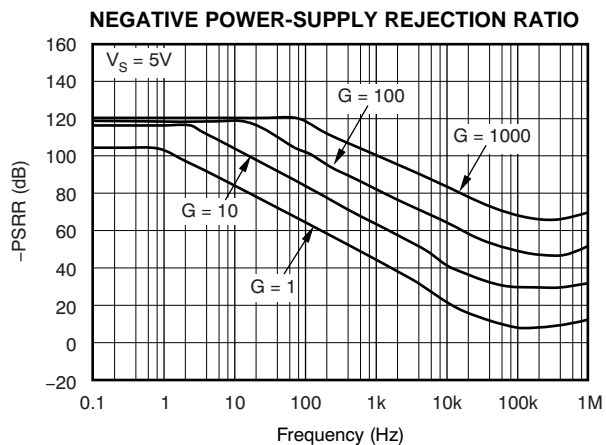

Figure 25.

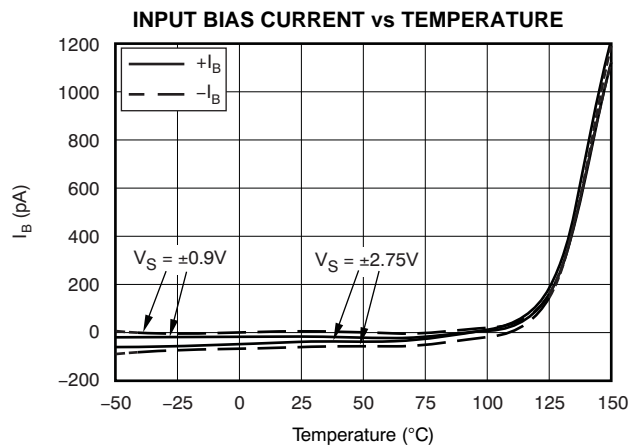

Figure 26.

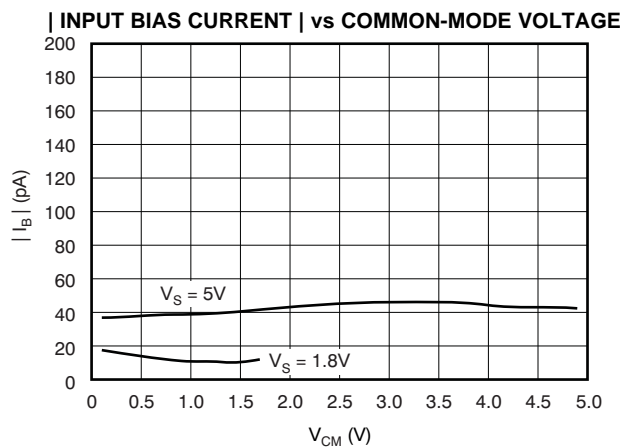

Figure 27.

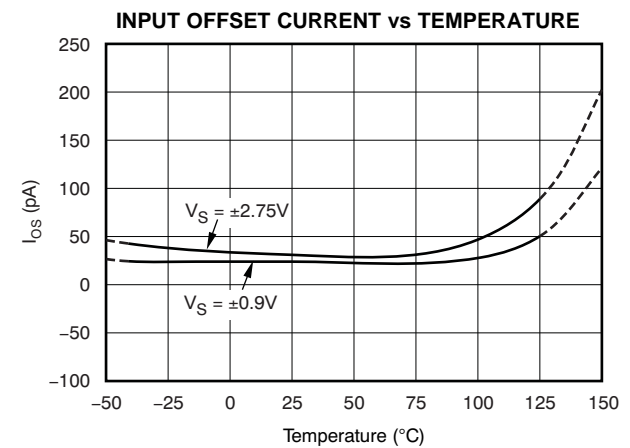

Figure 28.

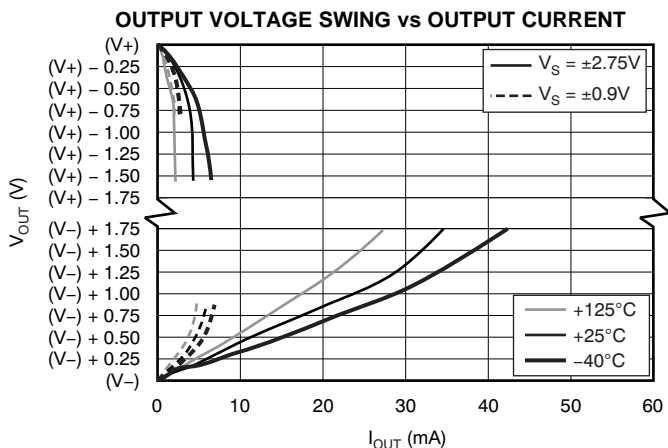

Figure 29.

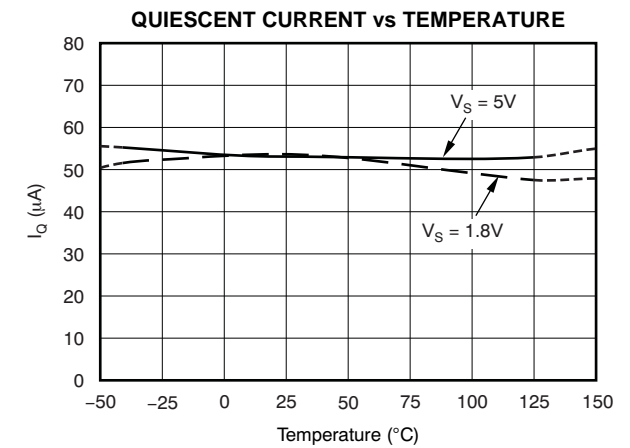
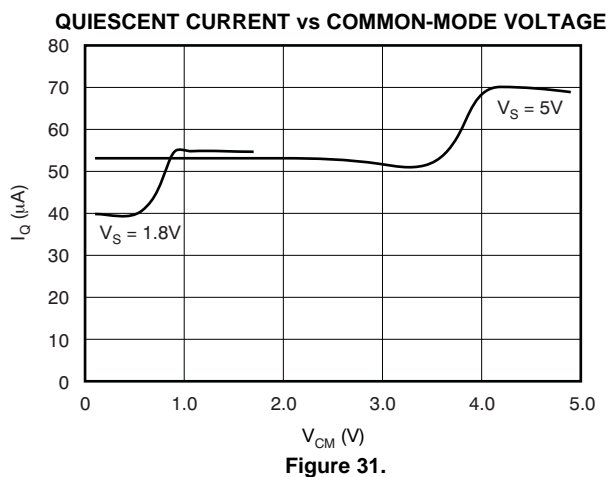

Figure 30.

TYPICAL CHARACTERISTICS (continued)

At $T_A = +25^\circ\text{C}$, $V_S = 5\text{V}$, $R_L = 10\text{k}\Omega$, $V_{REF} = \text{midsupply}$, and $G = 1$, unless otherwise noted.



APPLICATION INFORMATION

Figure 32 shows the basic connections required for operation of the INA333. Good layout practice mandates the use of bypass capacitors placed close to the device pins as shown.

The output of the INA333 is referred to the output reference (REF) terminal, which is normally grounded. This connection must be low-impedance to assure good common-mode rejection. Although 15Ω or less of stray resistance can be tolerated while maintaining specified CMRR, small stray resistances of tens of ohms in series with the REF pin can cause noticeable degradation in CMRR.

SETTING THE GAIN

Gain of the INA333 is set by a single external resistor, R_G , connected between pins 1 and 8. The value of R_G is selected according to Equation 1:

$$G = 1 + (100\text{k}\Omega/R_G) \quad (1)$$

Table 1 lists several commonly-used gains and resistor values. The 100kΩ term in Equation 1 comes from the sum of the two internal feedback resistors of A_1 and A_2 . These on-chip resistors are laser trimmed to accurate absolute values. The accuracy and temperature coefficient of these resistors are included in the gain accuracy and drift specifications of the INA333.

The stability and temperature drift of the external gain setting resistor, R_G , also affects gain. The contribution of R_G to gain accuracy and drift can be directly inferred from the gain Equation 1. Low resistor values required for high gain can make wiring resistance important. Sockets add to the wiring resistance and contribute additional gain error (possibly an unstable gain error) in gains of approximately 100 or greater. To ensure stability, avoid parasitic capacitance of more than a few picofarads at the R_G connections. Careful matching of any parasitics on both R_G pins maintains optimal CMRR over frequency.

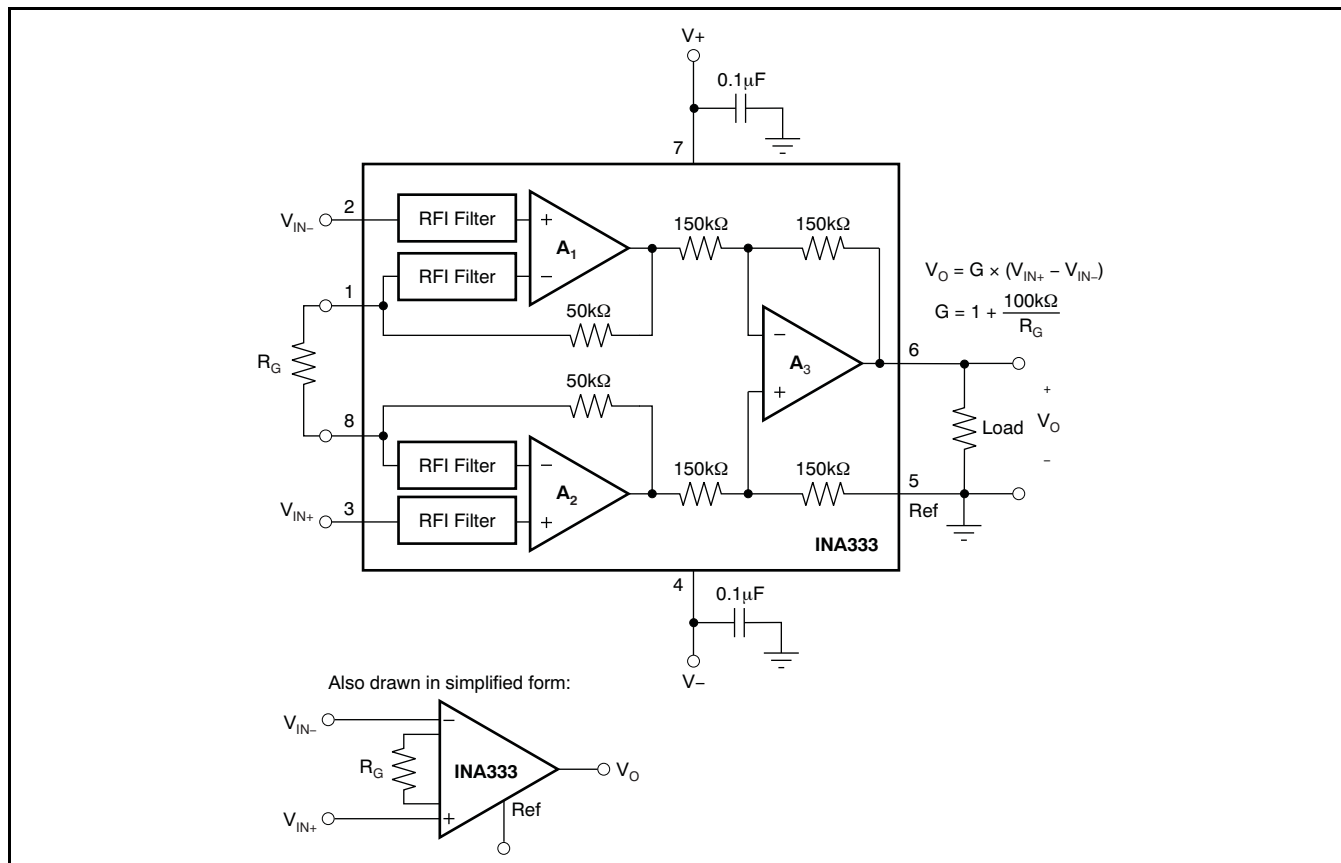

Figure 32. Basic Connections

Table 1. Commonly-Used Gains and Resistor Values

DESIRED GAIN	R _G (Ω)	NEAREST 1% R _G (Ω)
1	NC ⁽¹⁾	NC
2	100k	100k
5	25k	24.9k
10	11.1k	11k
20	5.26k	5.23k
50	2.04k	2.05
100	1.01k	1k
200	502.5	499
500	200.4	200
1000	100.1	100

(1) NC denotes no connection. When using the SPICE model, the simulation will not converge unless a resistor is connected to the R_G pins; use a very large resistor value.

INTERNAL OFFSET CORRECTION

The INA333 internal op amps use an auto-calibration technique with a time-continuous 350kHz op amp in the signal path. The amplifier is zero-corrected every 8μs using a proprietary technique. Upon power-up, the amplifier requires approximately 100μs to achieve specified V_{OS} accuracy. This design has no aliasing or flicker noise.

OFFSET TRIMMING

Most applications require no external offset adjustment; however, if necessary, adjustments can be made by applying a voltage to the REF terminal. Figure 33 shows an optional circuit for trimming the output offset voltage. The voltage applied to REF terminal is summed at the output. The op amp buffer provides low impedance at the REF terminal to preserve good common-mode rejection.

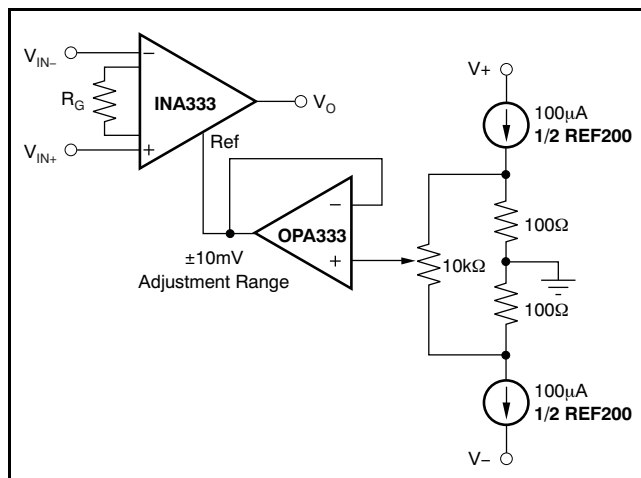

Figure 33. Optional Trimming of Output Offset Voltage

NOISE PERFORMANCE

The auto-calibration technique used by the INA333 results in reduced low frequency noise, typically only 50nV/√Hz, (G = 100). The spectral noise density can be seen in detail in Figure 8. Low frequency noise of the INA333 is approximately 1μV_{PP} measured from 0.1Hz to 10Hz, (G = 100).

INPUT BIAS CURRENT RETURN PATH

The input impedance of the INA333 is extremely high—approximately 100GΩ. However, a path must be provided for the input bias current of both inputs. This input bias current is typically ±70pA. High input impedance means that this input bias current changes very little with varying input voltage.

Input circuitry must provide a path for this input bias current for proper operation. Figure 34 illustrates various provisions for an input bias current path. Without a bias current path, the inputs will float to a potential that exceeds the common-mode range of the INA333, and the input amplifiers will saturate. If the differential source resistance is low, the bias current return path can be connected to one input (see the thermocouple example in Figure 34). With higher source impedance, using two equal resistors provides a balanced input with possible advantages of lower input offset voltage as a result of bias current and better high-frequency common-mode rejection.

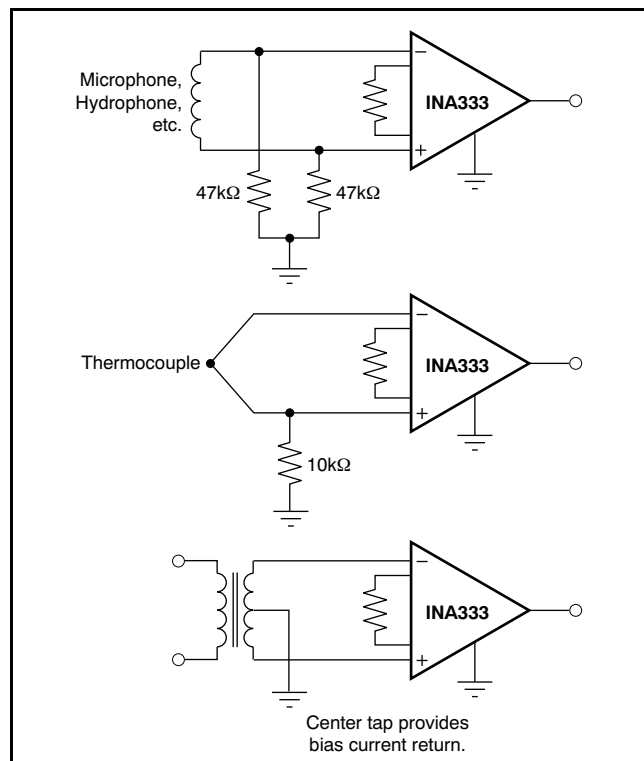

Figure 34. Providing an Input Common-Mode Current Path

INPUT COMMON-MODE RANGE

The linear input voltage range of the input circuitry of the INA333 is from approximately 0.1V below the positive supply voltage to 0.1V above the negative supply. As a differential input voltage causes the output voltage to increase, however, the linear input range is limited by the output voltage swing of amplifiers A_1 and A_2 . Thus, the linear common-mode input range is related to the output voltage of the complete amplifier. This behavior also depends on supply voltage—see Typical Characteristic curves *Typical Common-Mode Range vs Output Voltage* (Figure 20 to Figure 23).

Input overload conditions can produce an output voltage that appears normal. For example, if an input overload condition drives both input amplifiers to the respective positive output swing limit, the difference voltage measured by the output amplifier is near zero. The output of the INA333 is near 0V even though both inputs are overloaded.

OPERATING VOLTAGE

The INA333 operates over a power-supply range of +1.8V to +5.5V ($\pm 0.9V$ to $\pm 2.75V$). Supply voltages higher than +7V (absolute maximum) can permanently damage the device. Parameters that vary over supply voltage or temperature are shown in the [Typical Characteristics](#) section of this data sheet.

LOW VOLTAGE OPERATION

The INA333 can be operated on power supplies as low as $\pm 0.9V$. Most parameters vary only slightly throughout this supply voltage range—see the [Typical Characteristics](#) section. Operation at very low supply voltage requires careful attention to assure that the input voltages remain within the linear range. Voltage swing requirements of internal nodes limit the input common-mode range with low power-supply voltage. The Typical Characteristic curves *Typical Common-Mode Range vs Output Voltage* (Figure 20 to Figure 23) show the range of linear operation for various supply voltages and gains.

SINGLE-SUPPLY OPERATION

The INA333 can be used on single power supplies of +1.8V to +5.5V. Figure 35 illustrates a basic single-supply circuit. The output REF terminal is connected to mid-supply. Zero differential input voltage demands an output voltage of mid-supply. Actual output voltage swing is limited to approximately 50mV above ground, when the load is referred to ground as shown. The typical characteristic curve *Output Voltage Swing vs Output Current* (Figure 29) shows how the output voltage swing varies with output current.

With single-supply operation, V_{IN+} and V_{IN-} must both be 0.1V above ground for linear operation. For instance, the inverting input cannot be connected to ground to measure a voltage connected to the noninverting input.

To illustrate the issues affecting low voltage operation, consider the circuit in Figure 35. It shows the INA333 operating from a single 3V supply. A resistor in series with the low side of the bridge assures that the bridge output voltage is within the common-mode range of the amplifier inputs.

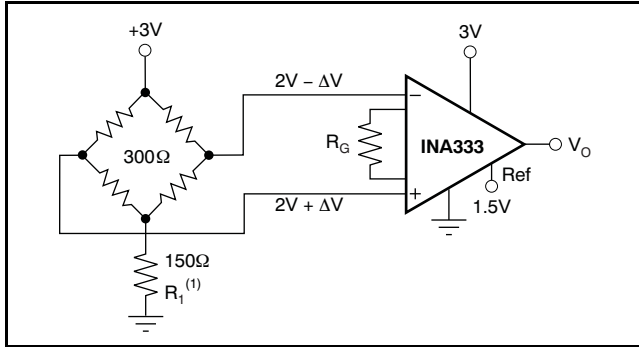

(1) R_1 creates proper common-mode voltage, only for low-voltage operation—see the [Single-Supply Operation](#) section.

Figure 35. Single-Supply Bridge Amplifier

INPUT PROTECTION

The input terminals of the INA333 are protected with internal diodes connected to the power-supply rails. These diodes clamp the applied signal to prevent it from damaging the input circuitry. If the input signal voltage can exceed the power supplies by more than 0.3V, the input signal current should be limited to less than 10mA to protect the internal clamp diodes. This current limiting can generally be done with a series input resistor. Some signal sources are inherently current-limited and do not require limiting resistors.

GENERAL LAYOUT GUIDELINES

Attention to good layout practices is always recommended. Keep traces short and, when possible, use a printed circuit board (PCB) ground plane with surface-mount components placed as close to the device pins as possible. Place a 0.1μF bypass capacitor closely across the supply pins. These guidelines should be applied throughout the analog circuit to improve performance and provide benefits such as reducing the electromagnetic-interference (EMI) susceptibility.

Instrumentation amplifiers vary in the susceptibility to radio-frequency interference (RFI). RFI can generally be identified as a variation in offset voltage or dc signal levels with changes in the interfering RF signal. The INA333 has been specifically designed to minimize susceptibility to RFI by incorporating passive RC filters with an 8MHz corner frequency at the V_{IN+} and V_{IN-} inputs. As a result, the INA333 demonstrates remarkably low sensitivity compared to previous generation devices. Strong RF fields may continue to cause varying offset levels, however, and may require additional shielding.

APPLICATION IDEAS

Additional application ideas are shown in [Figure 36](#) to [Figure 39](#).

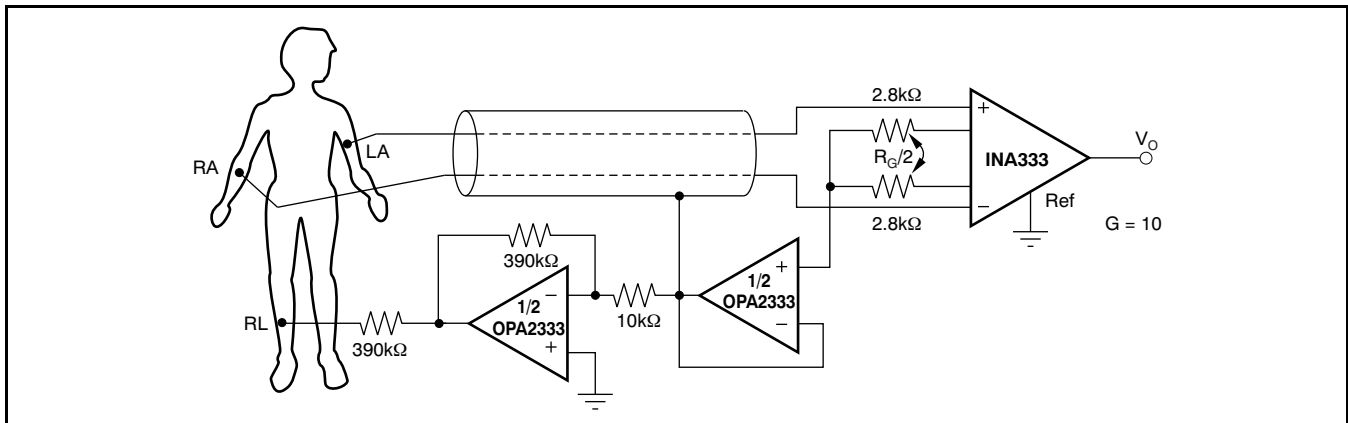

Figure 36. ECG Amplifier With Right-Leg Drive

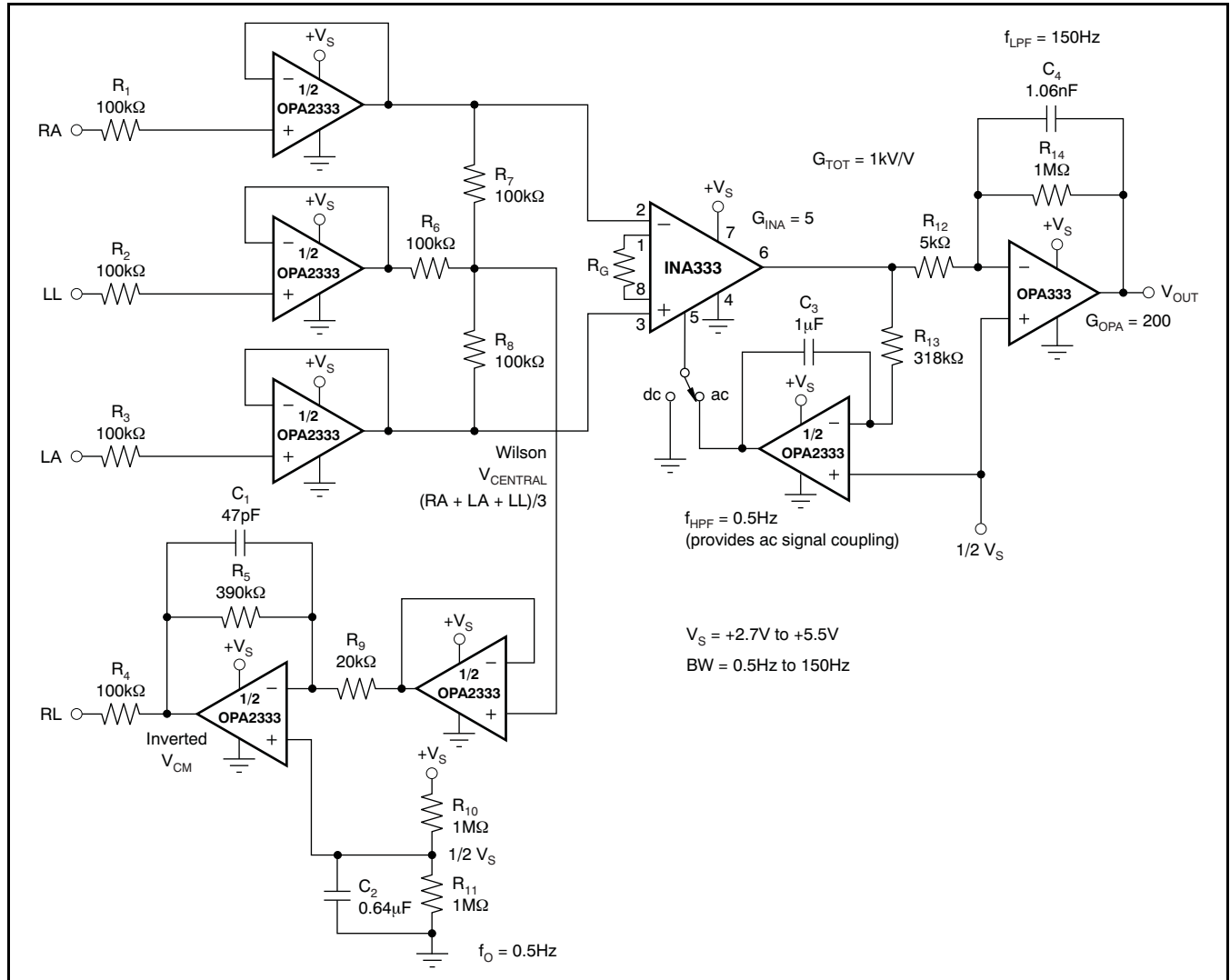

Figure 37. Single-Supply, Very Low Power, ECG Circuit

**TINA-TI
(FREE DOWNLOAD SOFTWARE)**

Using TINA-TI SPICE-Based Analog Simulation Program with the INA333

TINA is a simple, powerful, and easy-to-use circuit simulation program based on a SPICE engine. TINA-TI is a free, fully functional version of the TINA software, preloaded with a library of macromodels in addition to a range of both passive and active models. It provides all the conventional dc, transient, and frequency domain analysis of SPICE as well as additional design capabilities.

Available as a free download from the [Analog eLab Design Center](#), TINA-TI offers extensive post-processing capability that allows users to format results in a variety of ways.

Virtual instruments offer users the ability to select input waveforms and probe circuit nodes, voltages, and waveforms, creating a dynamic quick-start tool.

Figure 38 and Figure 39 show example TINA-TI circuits for the INA333 that can be used to develop, modify, and assess the circuit design for specific applications. Links to download these simulation files are given below.

NOTE: these files require that either the TINA software (from DesignSoft) or TINA-TI software be installed. Download the free TINA-TI software from the [TINA-TI folder](#).

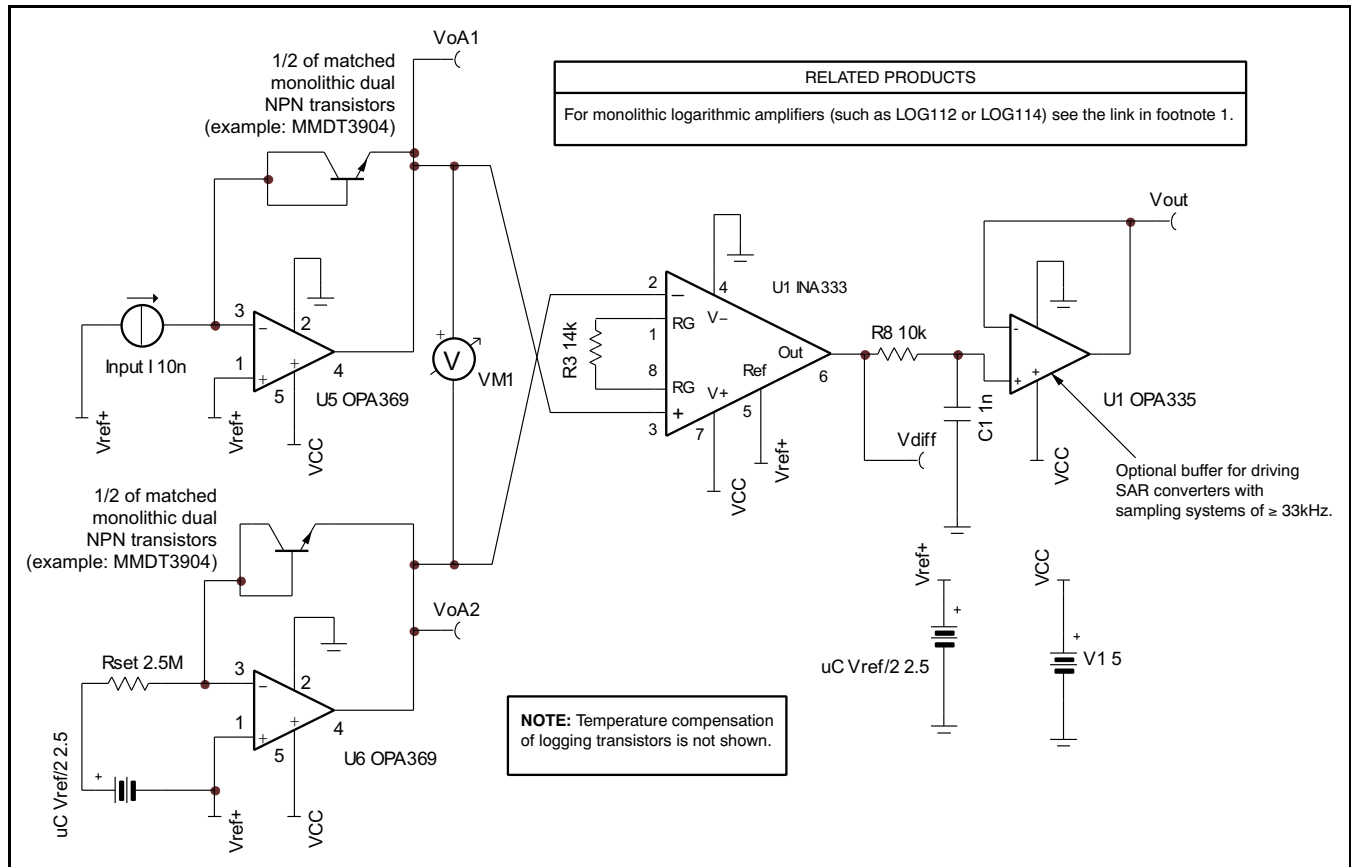

(1) The following link launches the TI logarithmic amplifiers web page: [Logarithmic Amplifier Products Home Page](#)

Figure 38. Low-Power Log Function Circuit for Portable Battery-Powered Systems (Example Glucose Meter)

To download a compressed file that contains the TINA-TI simulation file for this circuit, click the following link: [Log Circuit](#).

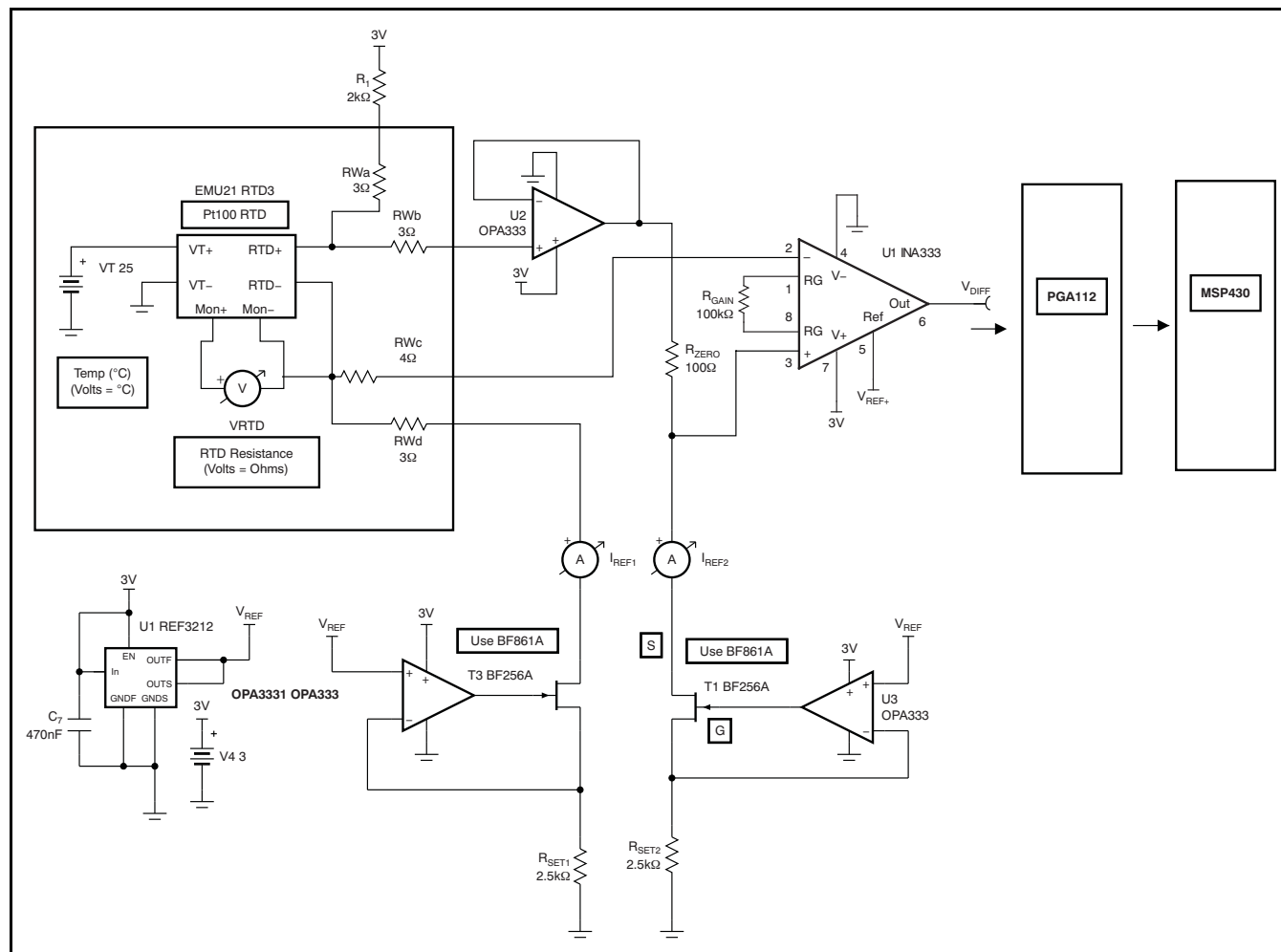

RWa, RWb, RWc, and RWd simulate wire resistance. These resistors are included to show the four-wire sense technique immunity to line mismatches. This method assumes the use of a four-wire RTD.

Figure 39. Four-Wire, 3V Conditioner for a PT100 RTD With Programmable Gain Acquisition System

To download a compressed file that contains the TINA-TI simulation file for this circuit, click the following link: [PT100 RTD](#).

PACKAGING INFORMATION

Orderable Device	Status (1)	Package Type	Package Drawing	Pins	Package Qty	Eco Plan (2)	Lead/Ball Finish (6)	MSL Peak Temp (3)	Op Temp (°C)	Device Marking (4/5)	Samples
INA333AIDGKR	ACTIVE	VSSOP	DGK	8	2500	Green (RoHS & no Sb/Br)	CU NIPDAU CU NIPDAUAG	Level-2-260C-1 YEAR	-40 to 125	I333	Samples
INA333AIDGKRG4	ACTIVE	VSSOP	DGK	8	2500	Green (RoHS & no Sb/Br)	CU NIPDAU	Level-2-260C-1 YEAR	-40 to 125	I333	Samples
INA333AIDGKT	ACTIVE	VSSOP	DGK	8	250	Green (RoHS & no Sb/Br)	CU NIPDAU CU NIPDAUAG	Level-2-260C-1 YEAR	-40 to 125	I333	Samples
INA333AIDGKTG4	ACTIVE	VSSOP	DGK	8	250	Green (RoHS & no Sb/Br)	CU NIPDAU	Level-2-260C-1 YEAR	-40 to 125	I333	Samples
INA333AIDRGR	ACTIVE	SON	DRG	8	3000	Green (RoHS & no Sb/Br)	CU NIPDAU	Level-2-260C-1 YEAR	-40 to 125	I333A	Samples
INA333AIDRGT	ACTIVE	SON	DRG	8	250	Green (RoHS & no Sb/Br)	CU NIPDAU	Level-2-260C-1 YEAR	-40 to 125	I333A	Samples

(1) The marketing status values are defined as follows:

ACTIVE: Product device recommended for new designs.

LIFEBUY: TI has announced that the device will be discontinued, and a lifetime-buy period is in effect.

NRND: Not recommended for new designs. Device is in production to support existing customers, but TI does not recommend using this part in a new design.

PREVIEW: Device has been announced but is not in production. Samples may or may not be available.

OBSOLETE: TI has discontinued the production of the device.

(2) Eco Plan - The planned eco-friendly classification: Pb-Free (RoHS), Pb-Free (RoHS Exempt), or Green (RoHS & no Sb/Br) - please check <http://www.ti.com/productcontent> for the latest availability information and additional product content details.

TBD: The Pb-Free/Green conversion plan has not been defined.

Pb-Free (RoHS): TI's terms "Lead-Free" or "Pb-Free" mean semiconductor products that are compatible with the current RoHS requirements for all 6 substances, including the requirement that lead not exceed 0.1% by weight in homogeneous materials. Where designed to be soldered at high temperatures, TI Pb-Free products are suitable for use in specified lead-free processes.

Pb-Free (RoHS Exempt): This component has a RoHS exemption for either 1) lead-based flip-chip solder bumps used between the die and package, or 2) lead-based die adhesive used between the die and leadframe. The component is otherwise considered Pb-Free (RoHS compatible) as defined above.

Green (RoHS & no Sb/Br): TI defines "Green" to mean Pb-Free (RoHS compatible), and free of Bromine (Br) and Antimony (Sb) based flame retardants (Br or Sb do not exceed 0.1% by weight in homogeneous material)

(3) MSL, Peak Temp. - The Moisture Sensitivity Level rating according to the JEDEC industry standard classifications, and peak solder temperature.

(4) There may be additional marking, which relates to the logo, the lot trace code information, or the environmental category on the device.

(5) Multiple Device Markings will be inside parentheses. Only one Device Marking contained in parentheses and separated by a "~" will appear on a device. If a line is indented then it is a continuation of the previous line and the two combined represent the entire Device Marking for that device.

⁽⁶⁾ Lead/Ball Finish - Orderable Devices may have multiple material finish options. Finish options are separated by a vertical ruled line. Lead/Ball Finish values may wrap to two lines if the finish value exceeds the maximum column width.

Important Information and Disclaimer: The information provided on this page represents TI's knowledge and belief as of the date that it is provided. TI bases its knowledge and belief on information provided by third parties, and makes no representation or warranty as to the accuracy of such information. Efforts are underway to better integrate information from third parties. TI has taken and continues to take reasonable steps to provide representative and accurate information but may not have conducted destructive testing or chemical analysis on incoming materials and chemicals. TI and TI suppliers consider certain information to be proprietary, and thus CAS numbers and other limited information may not be available for release.

In no event shall TI's liability arising out of such information exceed the total purchase price of the TI part(s) at issue in this document sold by TI to Customer on an annual basis.

OTHER QUALIFIED VERSIONS OF INA333 :

NOTE: Qualified Version Definitions:

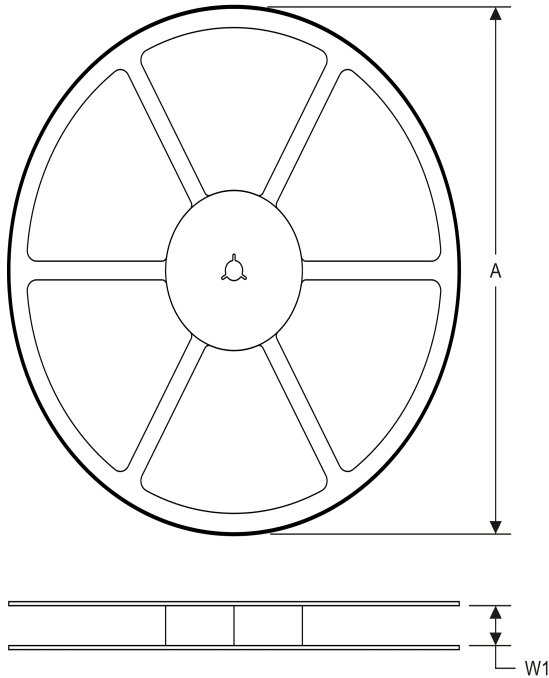
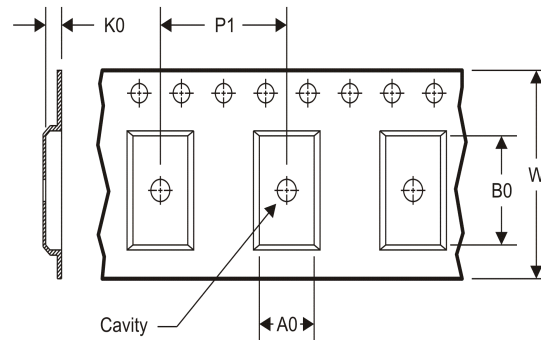
TAPE AND REEL INFORMATION
REEL DIMENSIONS

TAPE DIMENSIONS

A0	Dimension designed to accommodate the component width
B0	Dimension designed to accommodate the component length
K0	Dimension designed to accommodate the component thickness
W	Overall width of the carrier tape
P1	Pitch between successive cavity centers

TAPE AND REEL INFORMATION

*All dimensions are nominal

Device	Package Type	Package Drawing	Pins	SPQ	Reel Diameter (mm)	Reel Width W1 (mm)	A0 (mm)	B0 (mm)	K0 (mm)	P1 (mm)	W (mm)	Pin1 Quadrant
INA333AIDGKR	VSSOP	DGK	8	2500	330.0	12.4	5.3	3.4	1.4	8.0	12.0	Q1
INA333AIDGKT	VSSOP	DGK	8	250	330.0	12.4	5.3	3.4	1.4	8.0	12.0	Q1
INA333AIDRGR	SON	DRG	8	3000	330.0	12.4	3.3	3.3	1.1	8.0	12.0	Q2
INA333AIDRGT	SON	DRG	8	250	180.0	12.4	3.3	3.3	1.1	8.0	12.0	Q2

TAPE AND REEL BOX DIMENSIONS

*All dimensions are nominal

Device	Package Type	Package Drawing	Pins	SPQ	Length (mm)	Width (mm)	Height (mm)
INA333AIDGKR	VSSOP	DGK	8	2500	366.0	364.0	50.0
INA333AIDGKT	VSSOP	DGK	8	250	366.0	364.0	50.0
INA333AIDRGR	SON	DRG	8	3000	367.0	367.0	35.0
INA333AIDRGT	SON	DRG	8	250	210.0	185.0	35.0

DGK (S-PDSO-G8)

PLASTIC SMALL-OUTLINE PACKAGE

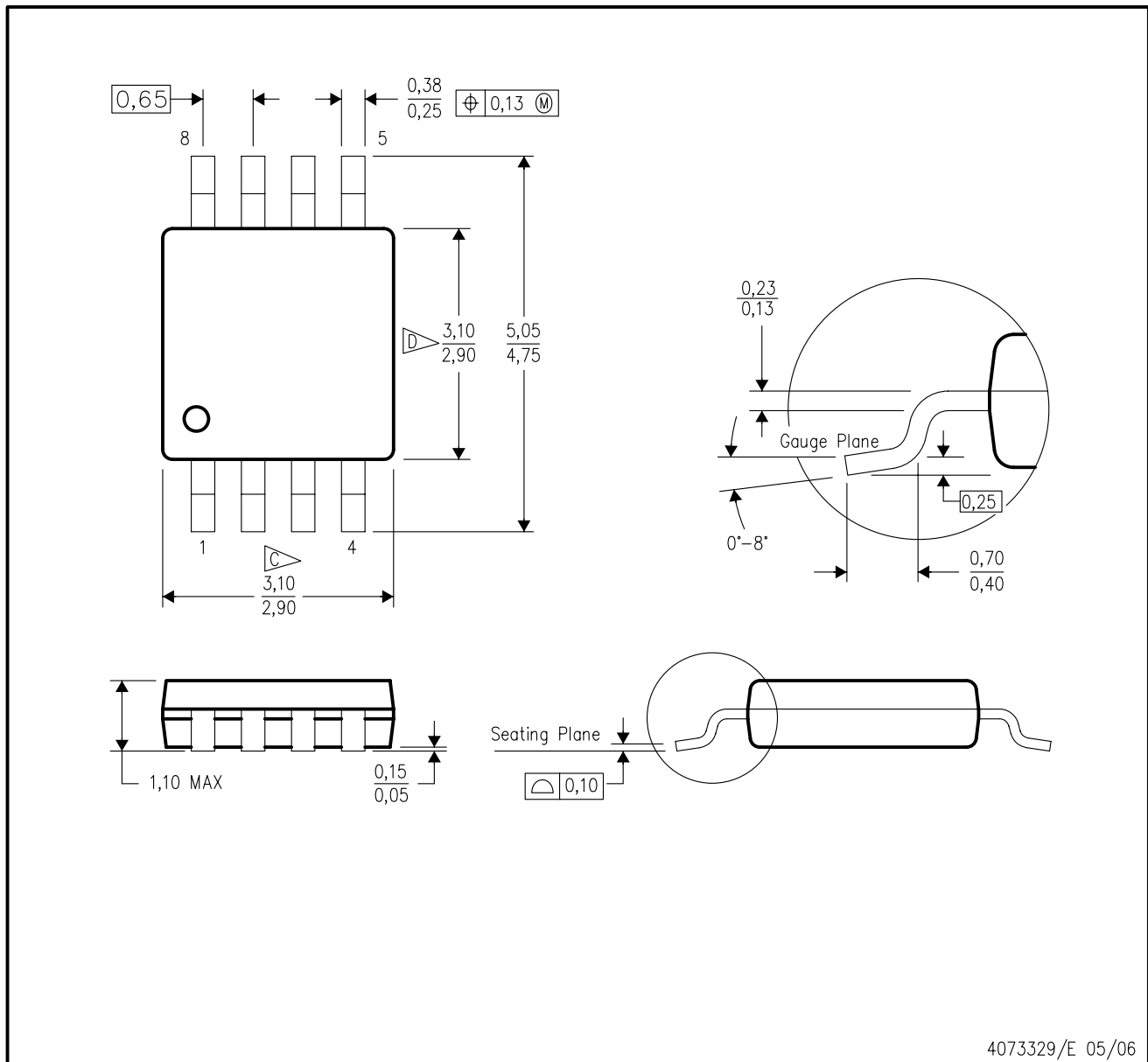

- NOTES:
- A. All linear dimensions are in millimeters.
 - B. This drawing is subject to change without notice.
 - C. Body length does not include mold flash, protrusions, or gate burrs. Mold flash, protrusions, or gate burrs shall not exceed 0.15 per end.
 - D. Body width does not include interlead flash. Interlead flash shall not exceed 0.50 per side.
 - E. Falls within JEDEC MO-187 variation AA, except interlead flash.

DRG (S-PWSON-N8)

PLASTIC SMALL OUTLINE NO-LEAD

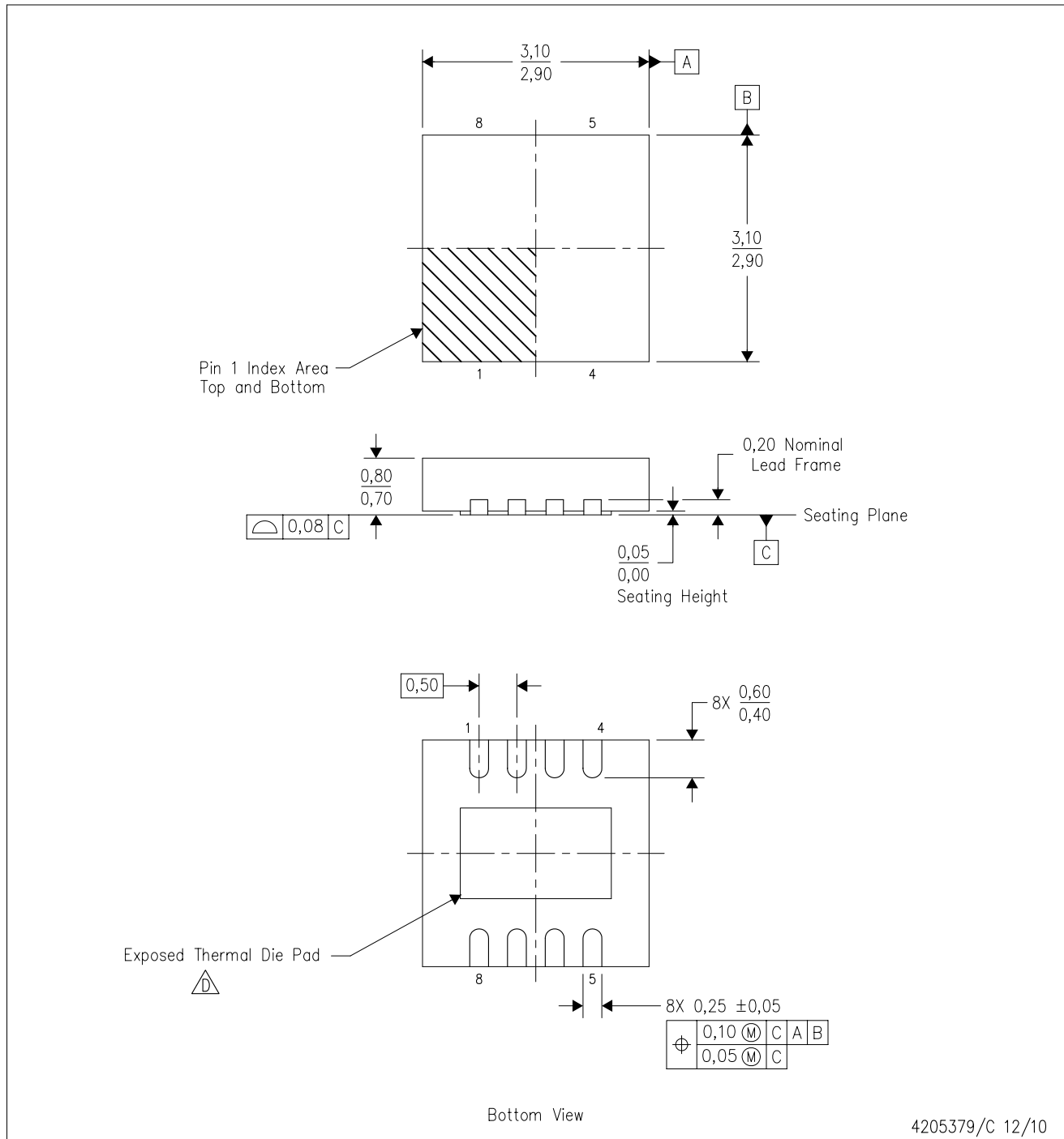

- NOTES:
- A. All linear dimensions are in millimeters. Dimensioning and tolerancing per ASME Y14.5M-1994.
 - B. This drawing is subject to change without notice.
 - C. SON (Small Outline No-Lead) package configuration.
 - D. The package thermal pad must be soldered to the board for thermal and mechanical performance. See the Product Data Sheet for details regarding the exposed thermal pad dimensions.
 - E. JEDEC MO-229 package registration pending.

THERMAL PAD MECHANICAL DATA

DRG (S-PWSON-N8)

PLASTIC SMALL OUTLINE NO-LEAD

THERMAL INFORMATION

This package incorporates an exposed thermal pad that is designed to be attached directly to an external heatsink. The thermal pad must be soldered directly to the printed circuit board (PCB). After soldering, the PCB can be used as a heatsink. In addition, through the use of thermal vias, the thermal pad can be attached directly to the appropriate copper plane shown in the electrical schematic for the device, or alternatively, can be attached to a special heatsink structure designed into the PCB. This design optimizes the heat transfer from the integrated circuit (IC).

For information on the Quad Flatpack No-Lead (QFN) package and its advantages, refer to Application Report, QFN/SON PCB Attachment, Texas Instruments Literature No. SLUA271. This document is available at www.ti.com.

The exposed thermal pad dimensions for this package are shown in the following illustration.

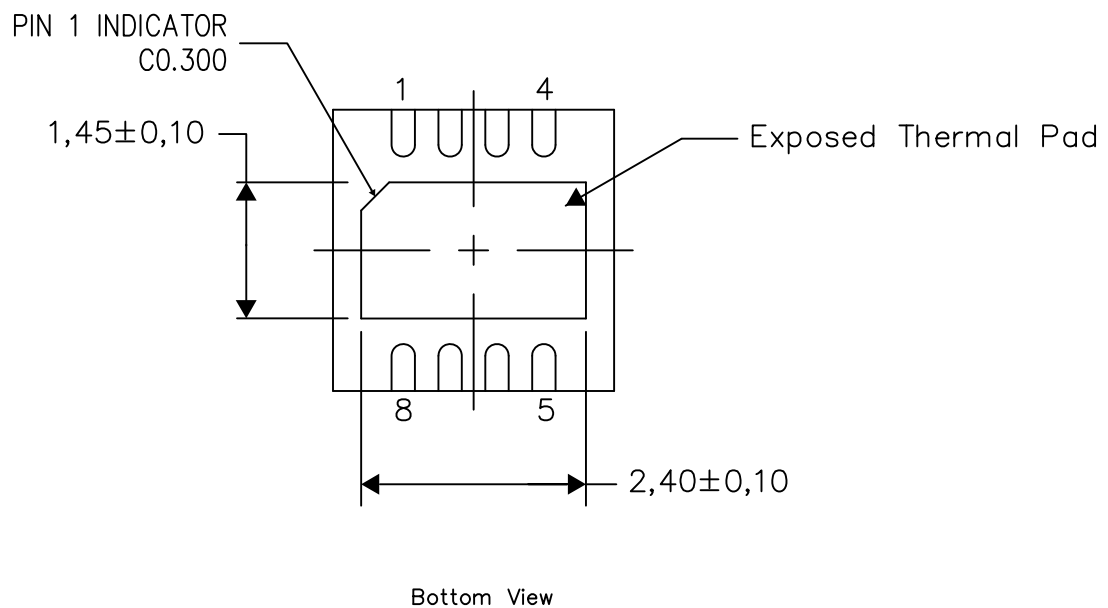

Exposed Thermal Pad Dimensions

4206881-3/G 04/12

NOTE: All linear dimensions are in millimeters

DRG (S-PWSON-N8)

PLASTIC SMALL OUTLINE NO-LEAD

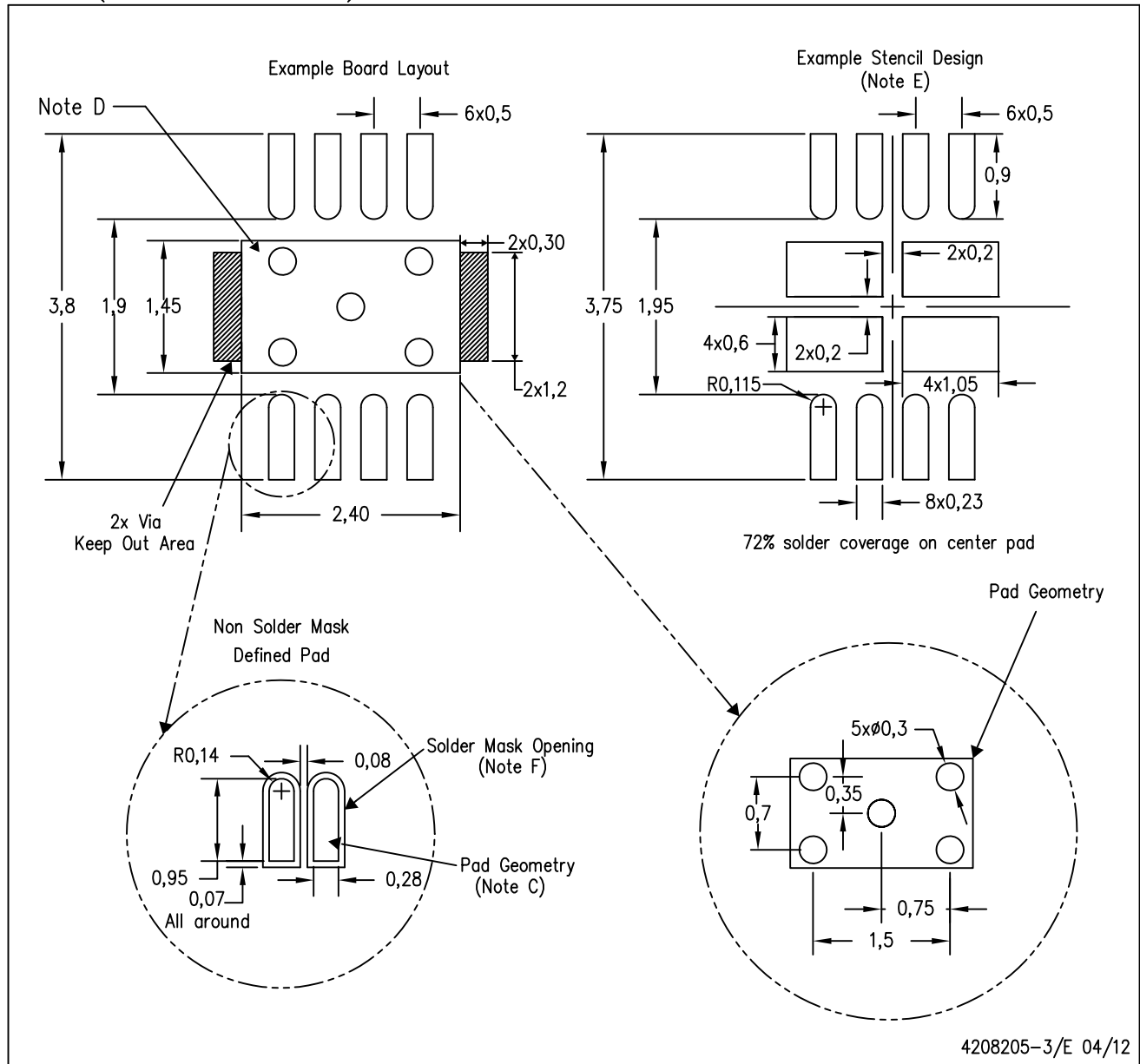

4208205-3/E 04/12

- NOTES:
- All linear dimensions are in millimeters.
 - This drawing is subject to change without notice.
 - Publication IPC-SM-782 is recommended for alternate designs.
 - This package is designed to be soldered to a thermal pad on the board. Refer to Application Note, Quad Flat-Pack Packages, Texas Instruments Literature No. SLUA271, and also the Product Data Sheets for specific thermal information, via requirements, and recommended board layout. These documents are available at www.ti.com <<http://www.ti.com>>.
 - Laser cutting apertures with trapezoidal walls and also rounding corners will offer better paste release. Customers should contact their board assembly site for stencil design recommendations. Refer to IPC 7525 for stencil design considerations.
 - Customers should contact their board fabrication site for minimum solder mask web tolerances between signal pads.

IMPORTANT NOTICE

Texas Instruments Incorporated and its subsidiaries (TI) reserve the right to make corrections, enhancements, improvements and other changes to its semiconductor products and services per JESD46, latest issue, and to discontinue any product or service per JESD48, latest issue. Buyers should obtain the latest relevant information before placing orders and should verify that such information is current and complete. All semiconductor products (also referred to herein as "components") are sold subject to TI's terms and conditions of sale supplied at the time of order acknowledgment.

TI warrants performance of its components to the specifications applicable at the time of sale, in accordance with the warranty in TI's terms and conditions of sale of semiconductor products. Testing and other quality control techniques are used to the extent TI deems necessary to support this warranty. Except where mandated by applicable law, testing of all parameters of each component is not necessarily performed.

TI assumes no liability for applications assistance or the design of Buyers' products. Buyers are responsible for their products and applications using TI components. To minimize the risks associated with Buyers' products and applications, Buyers should provide adequate design and operating safeguards.

TI does not warrant or represent that any license, either express or implied, is granted under any patent right, copyright, mask work right, or other intellectual property right relating to any combination, machine, or process in which TI components or services are used. Information published by TI regarding third-party products or services does not constitute a license to use such products or services or a warranty or endorsement thereof. Use of such information may require a license from a third party under the patents or other intellectual property of the third party, or a license from TI under the patents or other intellectual property of TI.

Reproduction of significant portions of TI information in TI data books or data sheets is permissible only if reproduction is without alteration and is accompanied by all associated warranties, conditions, limitations, and notices. TI is not responsible or liable for such altered documentation. Information of third parties may be subject to additional restrictions.

Resale of TI components or services with statements different from or beyond the parameters stated by TI for that component or service voids all express and any implied warranties for the associated TI component or service and is an unfair and deceptive business practice. TI is not responsible or liable for any such statements.

Buyer acknowledges and agrees that it is solely responsible for compliance with all legal, regulatory and safety-related requirements concerning its products, and any use of TI components in its applications, notwithstanding any applications-related information or support that may be provided by TI. Buyer represents and agrees that it has all the necessary expertise to create and implement safeguards which anticipate dangerous consequences of failures, monitor failures and their consequences, lessen the likelihood of failures that might cause harm and take appropriate remedial actions. Buyer will fully indemnify TI and its representatives against any damages arising out of the use of any TI components in safety-critical applications.

In some cases, TI components may be promoted specifically to facilitate safety-related applications. With such components, TI's goal is to help enable customers to design and create their own end-product solutions that meet applicable functional safety standards and requirements. Nonetheless, such components are subject to these terms.

No TI components are authorized for use in FDA Class III (or similar life-critical medical equipment) unless authorized officers of the parties have executed a special agreement specifically governing such use.

Only those TI components which TI has specifically designated as military grade or "enhanced plastic" are designed and intended for use in military/aerospace applications or environments. Buyer acknowledges and agrees that any military or aerospace use of TI components which have **not** been so designated is solely at the Buyer's risk, and that Buyer is solely responsible for compliance with all legal and regulatory requirements in connection with such use.

TI has specifically designated certain components as meeting ISO/TS16949 requirements, mainly for automotive use. In any case of use of non-designated products, TI will not be responsible for any failure to meet ISO/TS16949.

Products

Audio	www.ti.com/audio
Amplifiers	amplifier.ti.com
Data Converters	dataconverter.ti.com
DLP® Products	www.dlp.com
DSP	dsp.ti.com
Clocks and Timers	www.ti.com/clocks
Interface	interface.ti.com
Logic	logic.ti.com
Power Mgmt	power.ti.com
Microcontrollers	microcontroller.ti.com
RFID	www.ti-rfid.com
OMAP Applications Processors	www.ti.com/omap
Wireless Connectivity	www.ti.com/wirelessconnectivity

Applications

Automotive and Transportation	www.ti.com/automotive
Communications and Telecom	www.ti.com/communications
Computers and Peripherals	www.ti.com/computers
Consumer Electronics	www.ti.com/consumer-apps
Energy and Lighting	www.ti.com/energy
Industrial	www.ti.com/industrial
Medical	www.ti.com/medical
Security	www.ti.com/security
Space, Avionics and Defense	www.ti.com/space-avionics-defense
Video and Imaging	www.ti.com/video

TI E2E Community

e2e.ti.com