



# INA2132

## Dual, Low Power, Single-Supply DIFFERENCE AMPLIFIER

### FEATURES

- DESIGNED FOR LOW COST
- LOW QUIESCENT CURRENT:  
160 $\mu$ A per Amplifier
- WIDE POWER SUPPLY RANGE:  
Single Supply: 2.7V to 36V  
Dual Supplies:  $\pm 1.35$ V to  $\pm 18$ V
- LOW GAIN ERROR:  $\pm 0.05\%$  max
- LOW NONLINEARITY: 0.001% max
- HIGH CMRR: 90dB
- HIGHLY VERSATILE CIRCUIT
- EASY TO USE
- SO-14 PACKAGE

### APPLICATIONS

- DIFFERENTIAL INPUT AMPLIFIER
- INSTRUMENTATION AMPLIFIER  
BUILDING BLOCK
- UNITY-GAIN INVERTING AMPLIFIER
- G = 1/2 AMPLIFIER
- G = 2 AMPLIFIER
- SUMMING AMPLIFIER
- DIFFERENTIAL CURRENT RECEIVER
- VOLTAGE-CONTROLLED CURRENT SOURCE
- BATTERY-POWERED SYSTEMS
- GROUND LOOP ELIMINATOR

### DESCRIPTION

The INA2132 is a dual low power, unity-gain difference amplifier offering excellent value at very low cost. Each channel consists of a precision op amp with a laser-trimmed precision resistor network, providing accurate gain and high common-mode rejection. Excellent TCR tracking of the resistors maintains gain accuracy and common-mode rejection over temperature. The internal op amp's common-mode range extends to the negative supply—ideal for single-supply applications.

The difference amplifier is the foundation of many commonly used circuits. The INA2132 provides this circuit function without using an expensive precision resistor network. The INA2132 is available in the SO-14 surface-mount package and is specified for operation over the extended industrial temperature range,  $-40^{\circ}\text{C}$  to  $+85^{\circ}\text{C}$ .

A single version of this product with similar specifications is also available. See the INA132 data sheet for details.

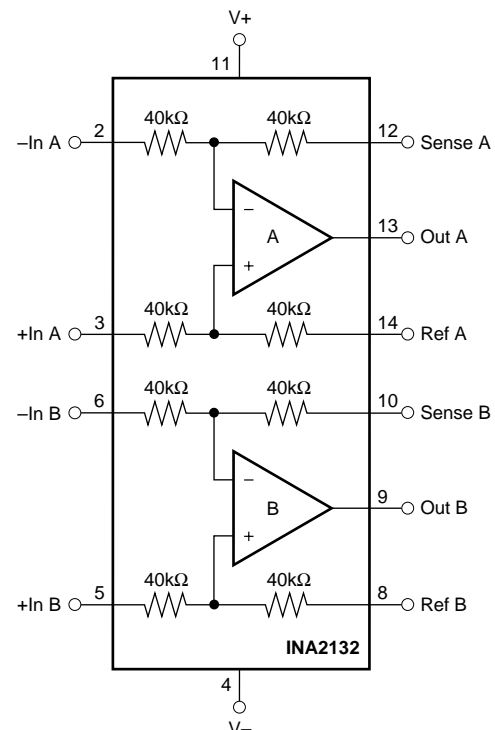

# SPECIFICATIONS: $V_S = \pm 15V$

At  $T_A = +25^\circ C$ ,  $R_L = 10k\Omega$  connected to ground, and reference pins connected to ground unless otherwise noted.

PARAMETER	CONDITIONS	INA2132U			INA2132UA			UNITS
		MIN	TYP	MAX	MIN	TYP	MAX	
<b>OFFSET VOLTAGE<sup>(1)</sup></b>	RTO							
Initial $V_{OS}$			$\pm 75$	$\pm 250$		*	$\pm 500$	$\mu V$
vs Temperature $dV_{OS}/dT$			$\pm 1$	$\pm 5$		*	$\pm 10$	$\mu V/^\circ C$
vs Power Supply PSRR	$V_S = \pm 1.35V$ to $\pm 18V$		$\pm 5$	$\pm 30$		*	*	$\mu V/V$
vs Time			0.3			*		$\mu V/mo$
Channel Separation <sup>(2)</sup>	dc		0.04			*		$\mu V/V$
<b>INPUT IMPEDANCE<sup>(3)</sup></b>								
Differential			80			*		$k\Omega$
Common-Mode			40			*		$k\Omega$
<b>INPUT VOLTAGE RANGE</b>								
Common-Mode Voltage Range <sup>(4)</sup>	$V_O = 0V$	2 (V-)		2 (V+) -2	*		*	V
Common-Mode Rejection Ratio CMRR	$V_{CM} = -30V$ to $28V$ , $R_S = 0\Omega$	80	90		74	*		dB
<b>OUTPUT VOLTAGE NOISE<sup>(5)</sup></b>	RTO							
f = 0.1Hz to 10Hz			1.6			*		$\mu Vp-p$
f = 1kHz			65			*		$nV/\sqrt{Hz}$
<b>GAIN</b>								
Initial			1			*		V/V
Error	$V_O = -14V$ to $13.5V$		$\pm 0.01$	$\pm 0.05$		*	$\pm 0.1$	%
vs Temperature			$\pm 1$	$\pm 10$		*	*	$ppm/^\circ C$
Nonlinearity	$V_O = -14V$ to $13.5V$		$\pm 0.0001$	$\pm 0.001$		*	$\pm 0.002$	% of FS
<b>OUTPUT</b>								
Voltage, Positive	$R_L = 100k\Omega$ to Ground	(V+) -1	(V+) -0.8		*	*		V
Negative	$R_L = 100k\Omega$ to Ground	(V-) +0.5	(V-) +0.15		*	*		V
Positive	$R_L = 10k\Omega$ to Ground	(V+) -1.5	(V+) -0.8		*	*		V
Negative	$R_L = 10k\Omega$ to Ground	(V-) +1	(V-) +0.25		*	*		V
Current Limit, per Amplifier	Continuous to Common		$\pm 12$			*		mA
Capacitive Load (stable operation)			10			*		nF
<b>FREQUENCY RESPONSE</b>								
Small-Signal Bandwidth	-3dB		300			*		kHz
Slew Rate	SR		0.1			*		V/ $\mu s$
Settling Time: 0.1%	$V_O = 10V$ Step		85			*		$\mu s$
0.01%	$V_O = 10V$ Step		88			*		$\mu s$
Overload Recovery Time	50% Overdrive		7			*		$\mu s$
<b>POWER SUPPLY</b>								
Rated Voltage $V_S$			$\pm 15$			*		V
Voltage Range		$\pm 1.35$		$\pm 18$	*		*	V
Quiescent Current (per amplifier) $I_Q$	$I_O = 0mA$		$\pm 160$	$\pm 185$		*	*	$\mu A$
<b>TEMPERATURE RANGE</b>								
Specification		-40		+85	*		*	$^\circ C$
Operation		-55		+125	*		*	$^\circ C$
Storage		-55		+125	*		*	$^\circ C$
Thermal Resistance $\theta_{JA}$			100			*		$^\circ C/W$

\* Specifications the same as INA2132U.

NOTES: (1) Includes effects of amplifier's input bias and offset currents. (2) Measured output offset change of one channel for a full-scale swing ( $V_O = -14V$  to  $13.5V$ ) on the opposite channel. (3)  $40k\Omega$  resistors are ratio matched but have  $\pm 20\%$  absolute value. (4)  $2 (V-) -V_{REF} < V_{CM} < 2 ((V+) -1) -V_{REF}$ . For more detail, see Applications Information section. (5) Includes effects of amplifier's input current noise and thermal noise contribution of resistor network.

The information provided herein is believed to be reliable; however, BURR-BROWN assumes no responsibility for inaccuracies or omissions. BURR-BROWN assumes no responsibility for the use of this information, and all use of such information shall be entirely at the user's own risk. Prices and specifications are subject to change without notice. No patent rights or licenses to any of the circuits described herein are implied or granted to any third party. BURR-BROWN does not authorize or warrant any BURR-BROWN product for use in life support devices and/or systems.

# SPECIFICATIONS: $V_S = +5V$ Single Supply

At  $T_A = +25^\circ\text{C}$ ,  $R_L = 10\text{k}\Omega$  connected to  $V_S/2$ , and reference pin connected to  $V_S/2$ , unless otherwise noted.

PARAMETER	CONDITIONS	INA2132U			INA2132UA			UNITS
		MIN	TYP	MAX	MIN	TYP	MAX	
<b>OFFSET VOLTAGE<sup>(1)</sup></b>	RTO							
Initial $V_{OS}$			$\pm 150$	$\pm 500$		*	$\pm 750$	$\mu\text{V}$
vs Temperature $dV_{OS}/dT$			$\pm 2$			*		$\mu\text{V}/^\circ\text{C}$
<b>INPUT VOLTAGE RANGE</b>								
Common-Mode Voltage Range <sup>(2)</sup>		-2.5		+5.5	*		*	V
Common-Mode Rejection CMRR	$V_{CM} = -2.5\text{V to } +5.5\text{V}$ , $R_S = 0\Omega$	80	90		74	*		dB
<b>OUTPUT</b>								
Voltage, Positive	$R_L = 100\text{k}\Omega$ to Ground	(V+) -1	(V+) -0.75		*	*		V
Negative	$R_L = 100\text{k}\Omega$ to Ground	+0.25	+0.06		*	*		V
Positive	$R_L = 10\text{k}\Omega$ to Ground	(V+) -1	(V+) -0.8		*	*		V
Negative	$R_L = 10\text{k}\Omega$ to Ground	+0.25	+0.12		*	*		V
<b>POWER SUPPLY</b>								
Rated Voltage $V_S$			+5			*		V
Voltage Range		+2.7		+36	*		*	V
Quiescent Current $I_Q$	$I_O = 0\text{mA}$		$\pm 155$	$\pm 185$		*	*	$\mu\text{A}$

\* Specifications the same as INA2132U.

NOTE: (1) Includes effects of amplifier's input bias and offset currents. (2)  $2(V-) - V_{REF} < V_{CM} < 2(V+) - V_{REF}$ . For more detail, see Applications Information section.

## PIN CONFIGURATION

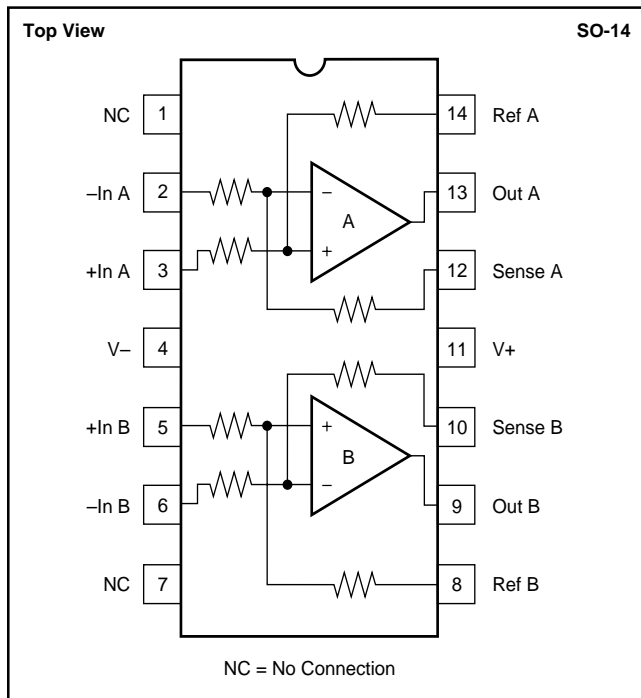

## ABSOLUTE MAXIMUM RATINGS

Supply Voltage, $V+$ to $V-$	36V
Input Voltage Range	$\pm 80\text{V}$
Output Short-Circuit (to ground)	Continuous
Operating Temperature	$-55^\circ\text{C to } +125^\circ\text{C}$
Storage Temperature	$-55^\circ\text{C to } +125^\circ\text{C}$
Junction Temperature	$+150^\circ\text{C}$
Lead Temperature (soldering, 10s)	$+300^\circ\text{C}$



## ELECTROSTATIC DISCHARGE SENSITIVITY

This integrated circuit can be damaged by ESD. Burr-Brown recommends that all integrated circuits be handled with appropriate precautions. Failure to observe proper handling and installation procedures can cause damage.

ESD damage can range from subtle performance degradation to complete device failure. Precision integrated circuits may be more susceptible to damage because very small parametric changes could cause the device not to meet its published specifications.

## PACKAGE/ORDERING INFORMATION

PRODUCT	PACKAGE	PACKAGE DRAWING NUMBER <sup>(1)</sup>	SPECIFIED TEMPERATURE RANGE	PACKAGE MARKING	ORDERING NUMBER <sup>(2)</sup>	TRANSPORT MEDIA
INA2132U	SO-14 Surface-Mount	235	$-40^\circ\text{C to } +85^\circ\text{C}$	INA2132U	INA2132U	Rails
"	"	"	"	"	INA2132U/2K5	Tape and Reel
INA2132UA	SO-14 Surface-Mount	235	$-40^\circ\text{C to } +85^\circ\text{C}$	INA2132UA	INA2132UA	Rails
"	"	"	"	"	INA2132UA/2K5	Tape and Reel

NOTES: (1) For detailed drawing and dimension table, please see end of data sheet, or Appendix C of Burr-Brown IC Data Book. (2) Models with a slash (/) are available only in Tape and Reel in the quantities indicated (e.g., /2K5 indicates 2500 devices per reel). Ordering 2500 pieces of "INA2132U/2K5" will get a single 2500-piece Tape and Reel. For detailed Tape and Reel mechanical information, refer to Appendix B of Burr-Brown IC Data Book.

# TYPICAL PERFORMANCE CURVES

At  $T_A = +25^\circ\text{C}$  and  $V_S = \pm 15\text{V}$ , unless otherwise noted.

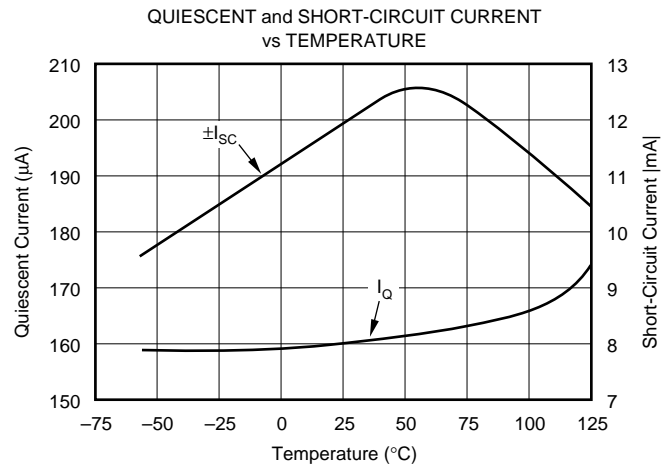
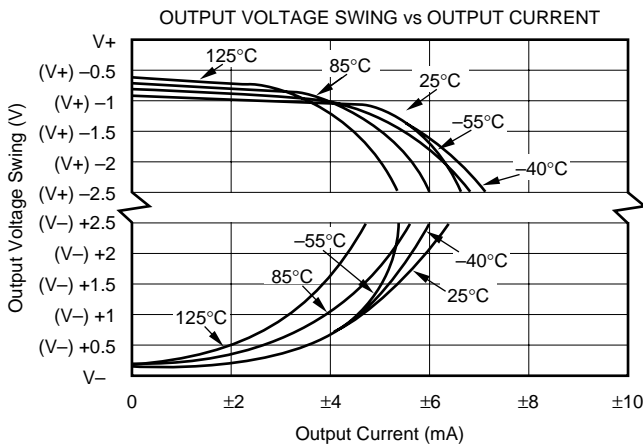
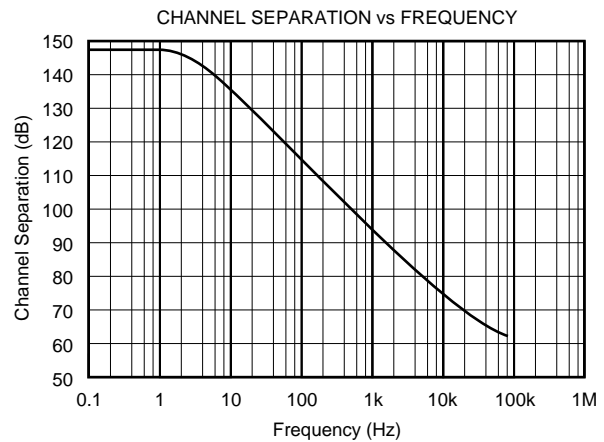
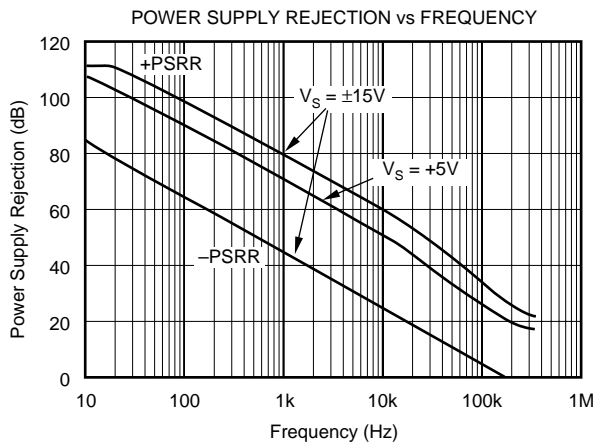
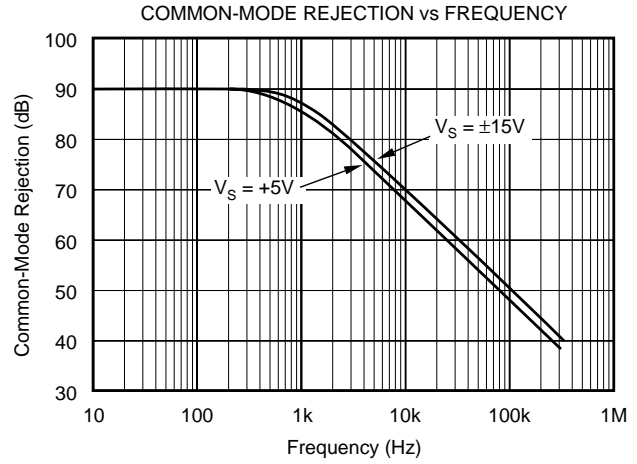
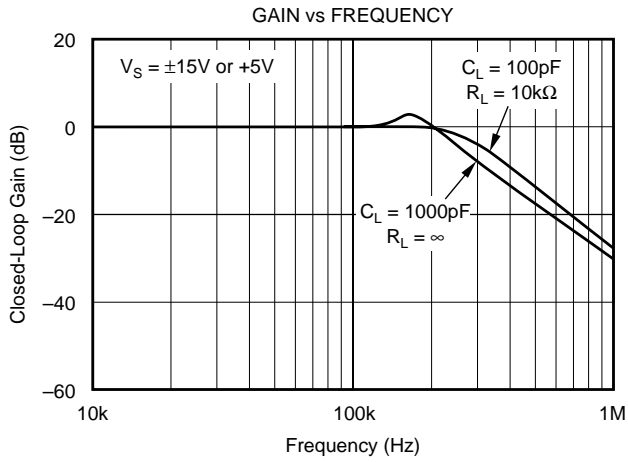

# TYPICAL PERFORMANCE CURVES (CONT)

At  $T_A = +25^\circ\text{C}$  and  $V_S = \pm 15\text{V}$ , unless otherwise noted.

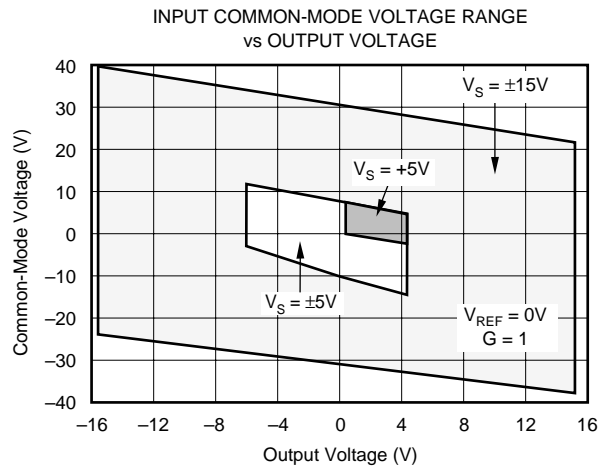
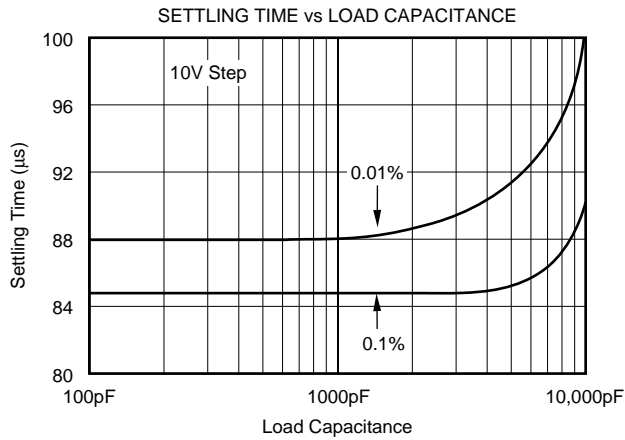
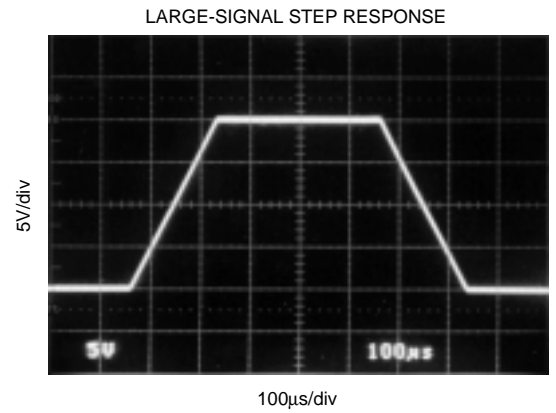
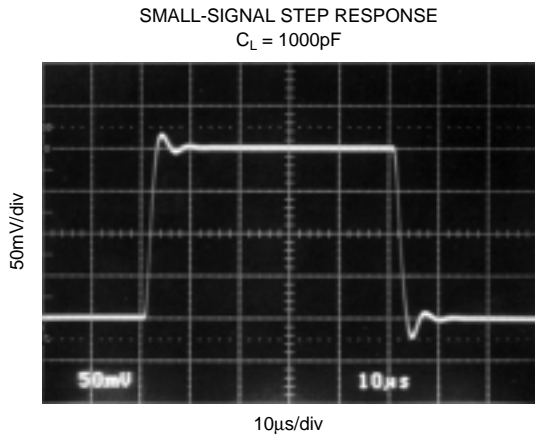
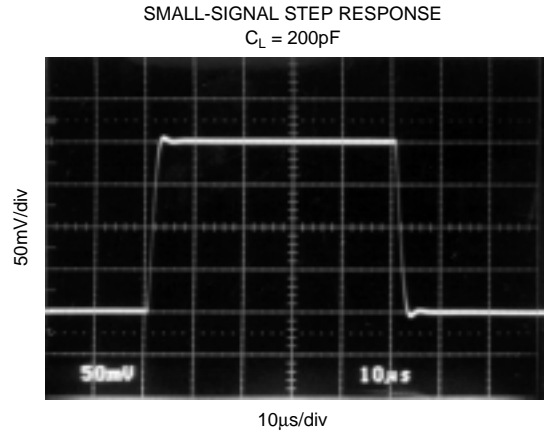
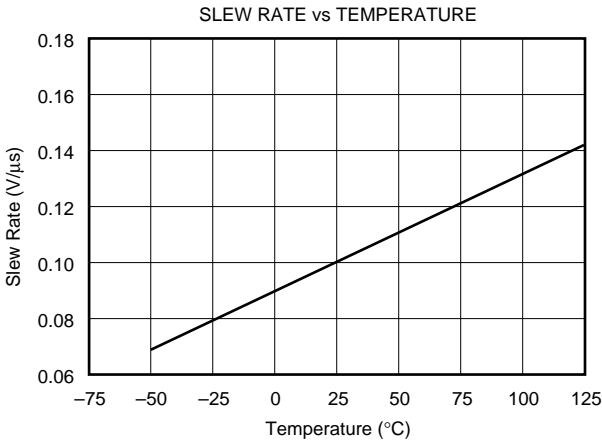

# TYPICAL PERFORMANCE CURVES (CONT)

At  $T_A = +25^\circ\text{C}$  and  $V_S = \pm 15\text{V}$ , unless otherwise noted.

0.1Hz to 10Hz PEAK-TO-PEAK  
VOLTAGE NOISE

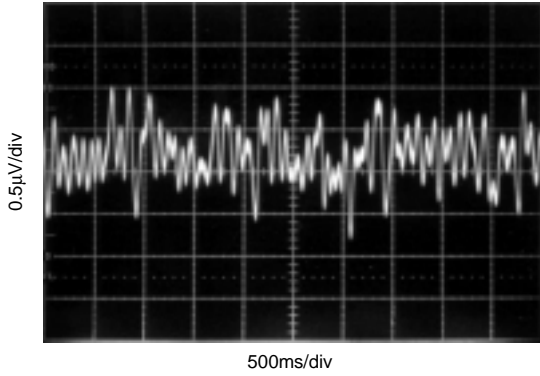

OFFSET VOLTAGE  
PRODUCTION DISTRIBUTION

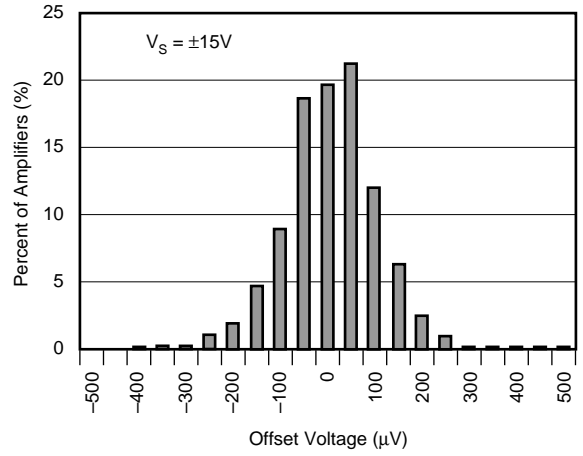

OFFSET VOLTAGE  
PRODUCTION DISTRIBUTION

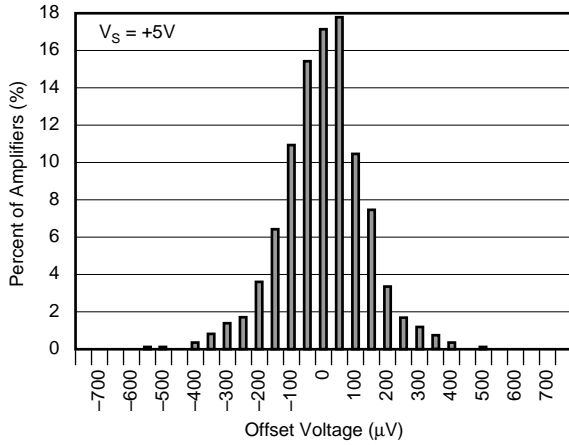

OFFSET VOLTAGE DRIFT  
PRODUCTION DISTRIBUTION

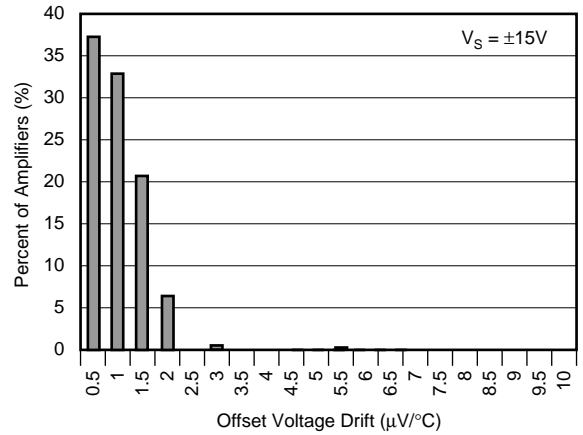

## APPLICATIONS INFORMATION

Figure 1 shows the basic connections required for operation of the INA2132. Power supply bypass capacitors should be connected close to the device pins.

The differential input signal is connected to pins 2 and 3 (or pins 6 and 5) as shown. The source impedances connected to the inputs must be nearly equal to assure good common-mode rejection. An 8Ω mismatch in source impedance will degrade the common-mode rejection of a typical device to approximately 80dB. Gain accuracy will also be slightly affected. If the source has a known impedance mismatch, an additional resistor in series with one input can be used to preserve good common-mode rejection.

Do not interchange pins 3 and 14 (or pins 5 and 8) or pins 2 and 12 (or pins 6 and 10), even though nominal resistor values are equal. These resistors are laser-trimmed for precise resistor ratios to achieve accurate gain and highest CMRR. Interchanging these pins may not provide specified performance. As shown in Figure 1, sense line should be connected as close to the load as possible.

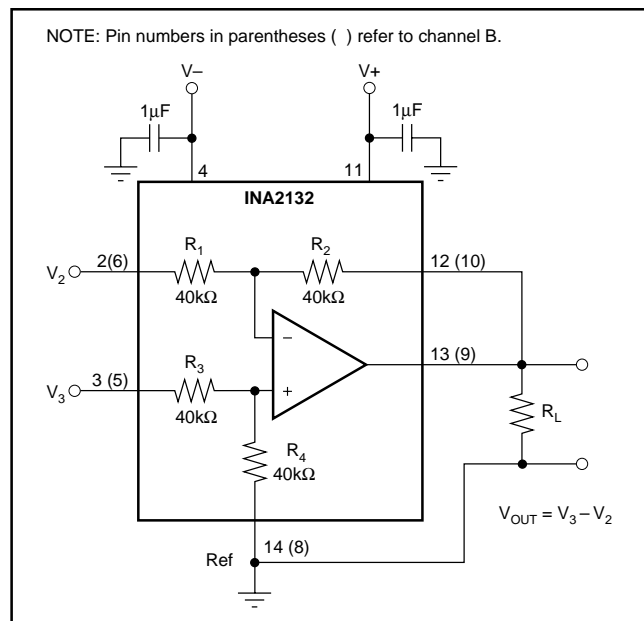

FIGURE 1. Basic Power Supply and Signal Connections.

To ensure valid operation of the differential amplifier, please note the following points:

- 1)  $V_{OUT} = V_3 - V_2 + V_{REF}$
- 2)  $V_{OUT}$  must be within the specified linear range. For example, with  $\pm 15V$  supplies and a  $100k\Omega$  load, the output will be defined by:

$$(V-) + 0.15V < V_{OUT} < (V+) - 0.8V$$

- 3) Input common-mode range at the nodes of the op amp must be  $V- \leq V_{CM} \leq (V+) - 1$ . To ensure that the inputs to the differential amp (+In and -In) meet this criteria, limit the common-mode voltage inputs to:

$$2 \cdot (V-) - V_{REF} < V_{CM} < 2 \cdot ((V+) - 1) - V_{REF}$$

In the case where  $V_{REF}$  is grounded, the equation simplifies to:

$$2 \cdot (V-) < V_{CM} < 2 \cdot ((V+) - 1)$$

For more information, see the typical performance curve titled “Input Common-Mode Voltage Range vs Output Voltage.”

## OPERATING VOLTAGE

The INA2132 operates from single ( $+2.7V$  to  $+36V$ ) or dual ( $\pm 1.35V$  to  $\pm 18V$ ) supplies with excellent performance. Specifications are production tested with  $+5V$  and  $\pm 15V$  supplies. Most behavior remains unchanged throughout the full operating voltage range. Parameters which vary significantly with operating voltage are shown in the Typical Performance Curves.

The INA2132 can accurately measure differential signals that are beyond the power supply rails. Linear common-mode range extends to twice the negative power supply voltage and nearly twice the positive power supply voltage. Output phase reversal does not occur when the inputs to the internal operational amplifier are overloaded to either rail. See typical performance curve, “Common-Mode Range vs Output Voltage.”

## OFFSET VOLTAGE TRIM

The INA2132 is laser-trimmed for low offset voltage and drift. Most applications require no external offset adjustment. Figure 2 shows an optional circuit for trimming the output offset voltage. The output is referred to the output reference terminal (pin 14 or pin 8), which is normally grounded. A voltage applied to the Ref terminal will be summed with the output signal. This can be used to null offset voltage. The source impedance of a signal applied to the Ref terminal should be less than  $8\Omega$  to maintain good common-mode rejection. To assure low impedance at the Ref terminal, the trim voltage can be buffered with an op amp, such as the OPA277.

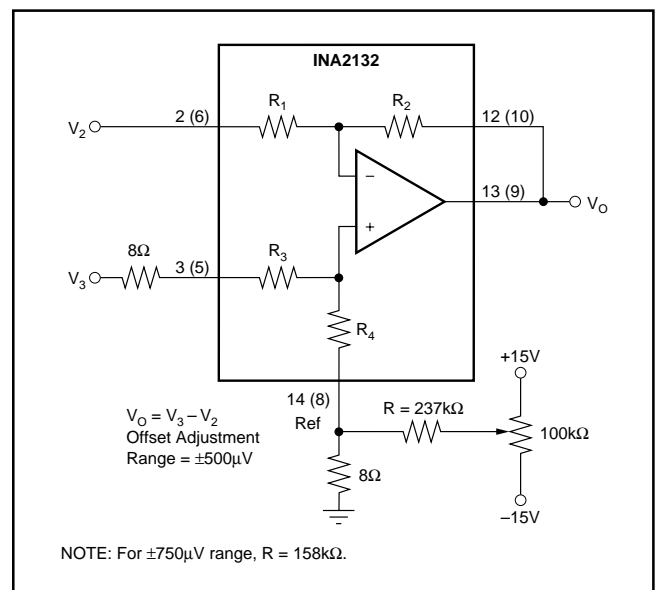

FIGURE 2. Offset Adjustment.

## CAPACITIVE LOAD DRIVE CAPABILITY

The INA2132 can drive large capacitive loads, even at low supplies. It is stable with a 10nF load. Refer to the “Small-Signal Step Response” and “Settling Time vs Load Capacitance” typical performance curves.

## CHANNEL CROSSTALK

The two channels of the INA2132 are completely independent, including all bias circuitry. At dc and low frequency, there is virtually no signal coupling between channels. Crosstalk increases with frequency and is dependent on source impedance and signal characteristics. See the typical performance curve “Channel Separation vs Frequency” for more information.

Most crosstalk is produced by capacitive coupling of signals from one channel to the input section of the other channel. To minimize coupling, separate the input traces as far as practical from any signals associated with the opposite channel. A grounded guard trace surrounding the inputs helps reduce stray coupling between channels. Run the differential inputs of each channel parallel to each other or

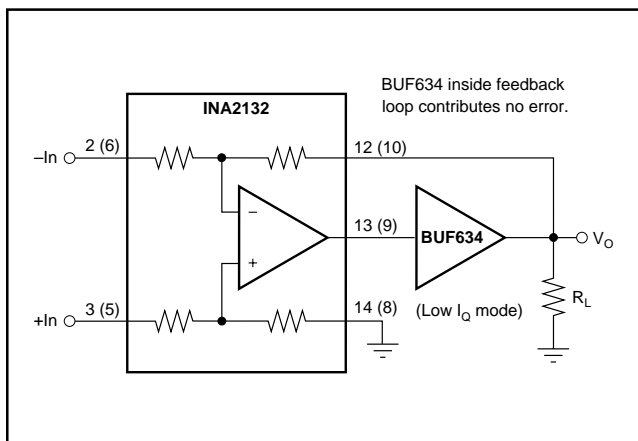

FIGURE 3. Low Power, High Output Current Precision Difference Amplifier.

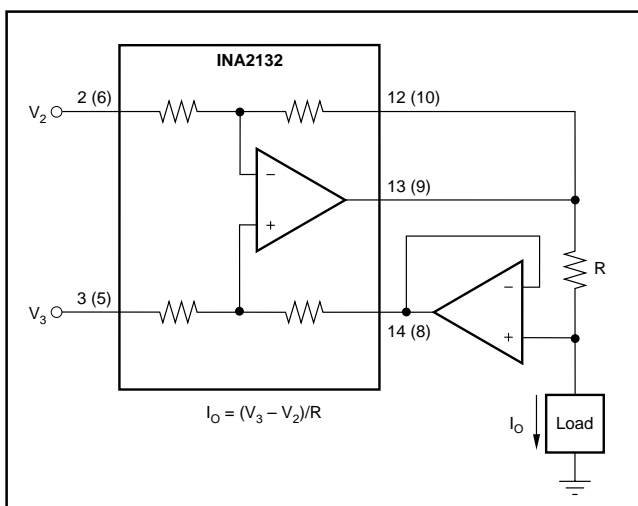

FIGURE 4. Differential Input Voltage-to-Current Converter for Low  $I_{OUT}$ .

directly adjacent on the top and bottom sides of a circuit board. Stray coupling then produces a common-mode signal which is rejected by the INA2132’s input.

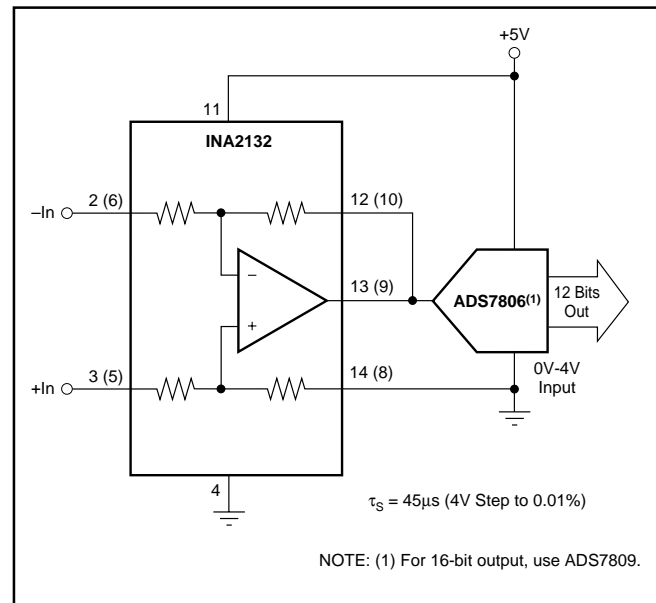

FIGURE 5. Differential Input Data Acquisition.

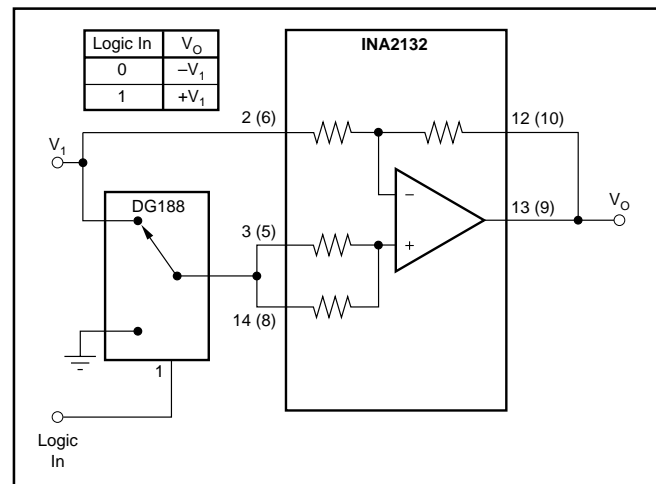

FIGURE 6. Digitally Controlled Gain of  $\pm 1$  Amplifier.

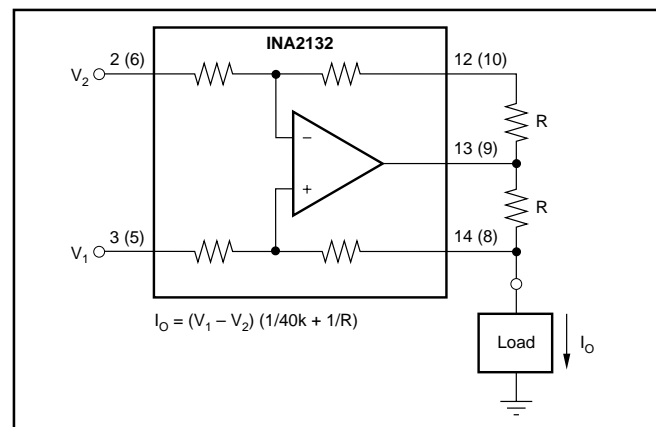

FIGURE 7. Precision Voltage-to-Current Converter with Differential Inputs.

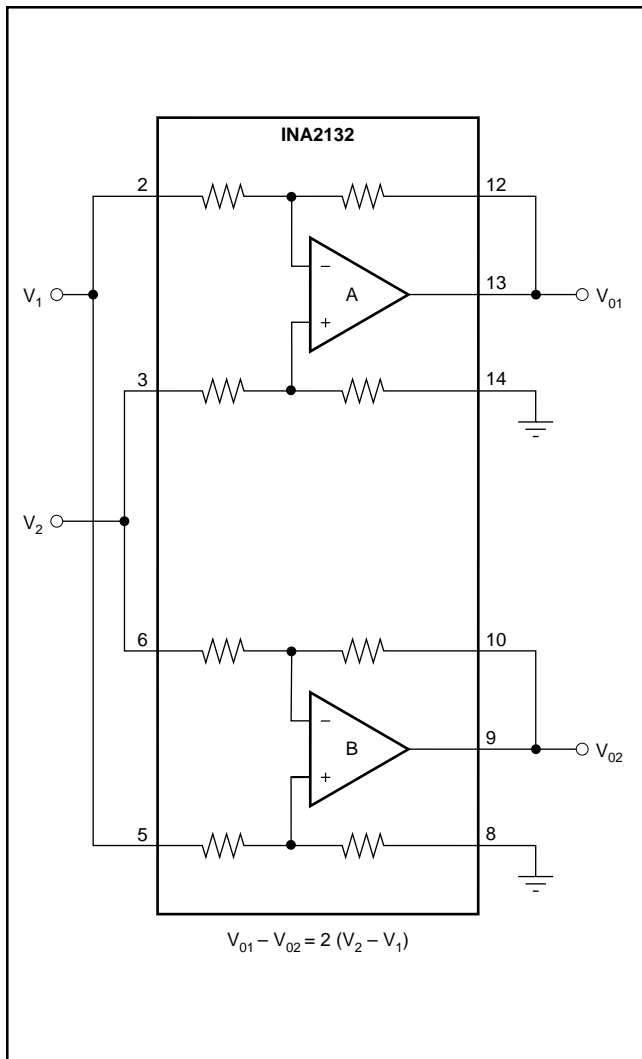

FIGURE 8. Differential Output Difference Amplifier.

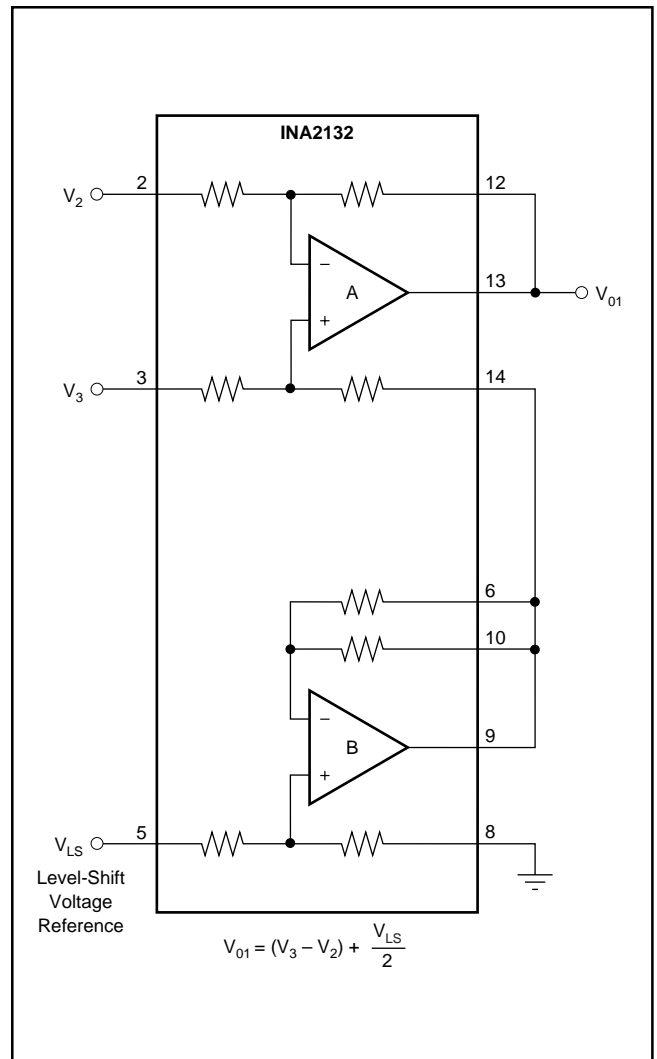
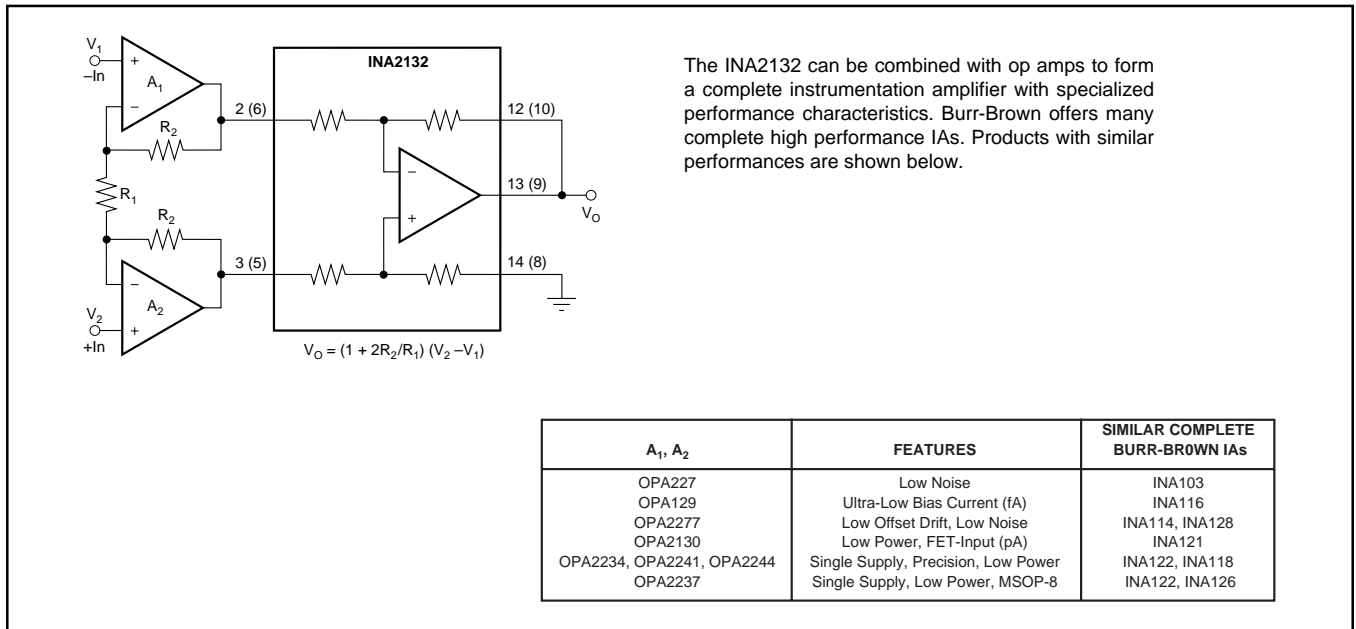

FIGURE 9. Precision Level Shifter.



The INA2132 can be combined with op amps to form a complete instrumentation amplifier with specialized performance characteristics. Burr-Brown offers many complete high performance IAs. Products with similar performances are shown below.

A <sub>1</sub> , A <sub>2</sub>	FEATURES	SIMILAR COMPLETE BURR-BROWN IAs
OPA227 OPA129 OPA2277 OPA2130 OPA2234, OPA2241, OPA2244 OPA2237	Low Noise Ultra-Low Bias Current (fA) Low Offset Drift, Low Noise Low Power, FET-Input (pA) Single Supply, Precision, Low Power Single Supply, Low Power, MSOP-8	INA103 INA116 INA114, INA128 INA121 INA122, INA118 INA122, INA126

FIGURE 10. Precision Instrumentation Amplifier.

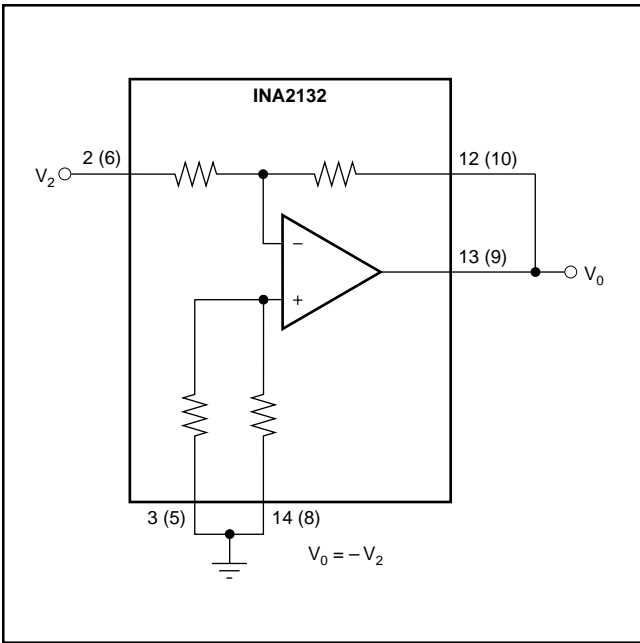

FIGURE 11. Precision Inverting Unity-Gain Amplifier.

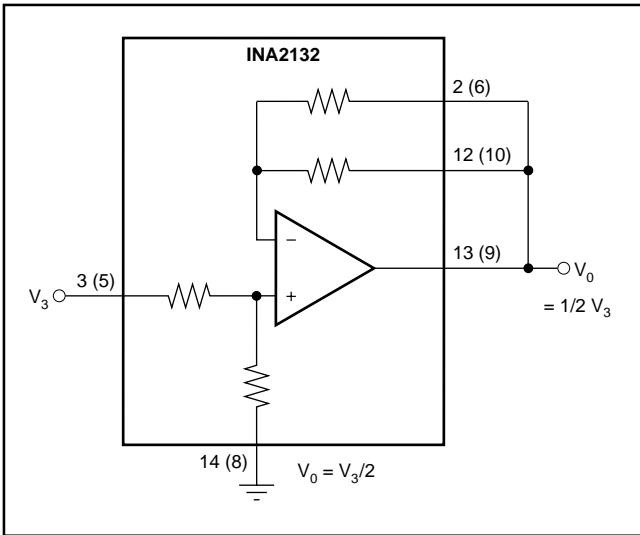

FIGURE 12. Precision Gain = 1/2 Amplifier.

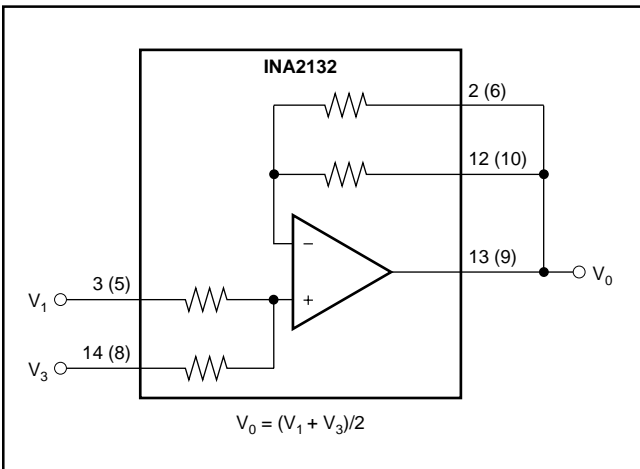

FIGURE 13. Precision Average Value Amplifier.

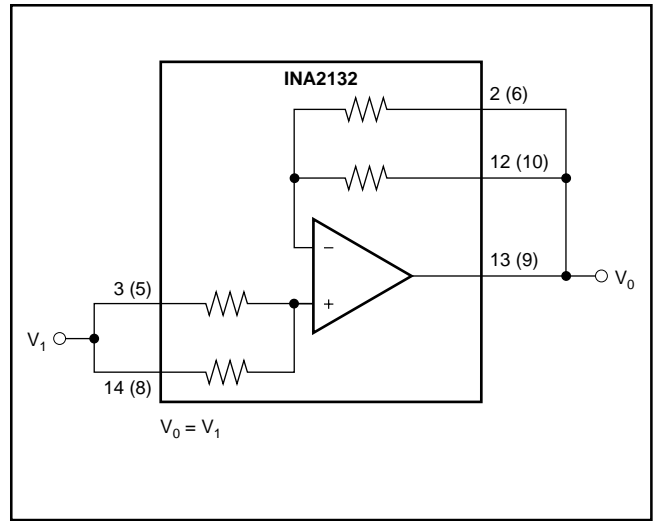

FIGURE 14. Precision Unity-Gain Buffer.

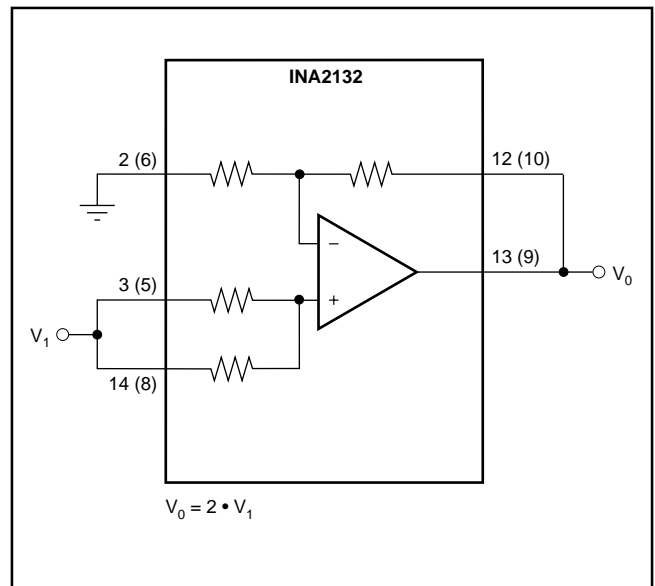

FIGURE 15. Precision Gain = 2 Amplifier.

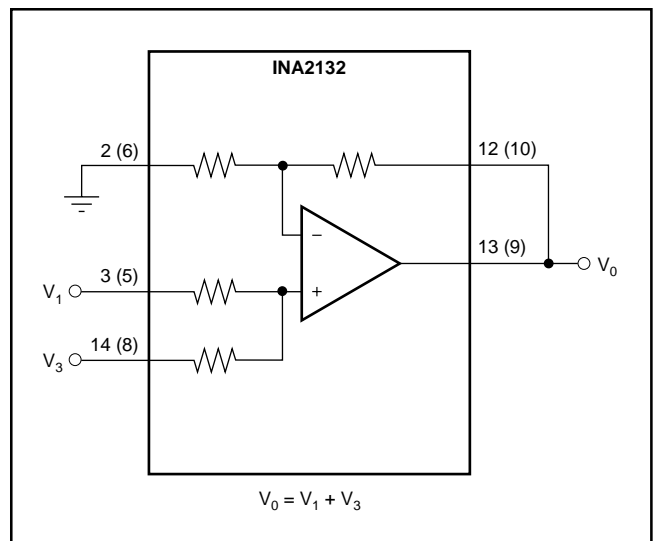

FIGURE 16. Precision Summing Amplifier.

**PACKAGING INFORMATION**

Orderable Device	Status <sup>(1)</sup>	Package Type	Package Drawing	Pins	Package Qty	Eco Plan <sup>(2)</sup>	Lead/Ball Finish	MSL Peak Temp <sup>(3)</sup>
INA2132U	ACTIVE	SOIC	D	14	58	Green (RoHS & no Sb/Br)	CU NIPDAU	Level-3-260C-168 HR
INA2132U/2K5E4	ACTIVE	SOIC	D	14	2500	TBD	Call TI	Call TI
INA2132UA	ACTIVE	SOIC	D	14	58	Green (RoHS & no Sb/Br)	CU NIPDAU	Level-3-260C-168 HR
INA2132UA/2K5	ACTIVE	SOIC	D	14	2500	Green (RoHS & no Sb/Br)	CU NIPDAU	Level-3-260C-168 HR
INA2132UA/2K5E4	ACTIVE	SOIC	D	14		TBD	Call TI	Call TI
INA2132UA/2K5G4	ACTIVE	SOIC	D	14	2500	Green (RoHS & no Sb/Br)	CU NIPDAU	Level-3-260C-168 HR
INA2132UAE4	ACTIVE	SOIC	D	14	58	Green (RoHS & no Sb/Br)	CU NIPDAU	Level-3-260C-168 HR
INA2132UAG4	ACTIVE	SOIC	D	14	58	Green (RoHS & no Sb/Br)	CU NIPDAU	Level-3-260C-168 HR
INA2132UE4	ACTIVE	SOIC	D	14	58	Green (RoHS & no Sb/Br)	CU NIPDAU	Level-3-260C-168 HR
INA2132UG4	ACTIVE	SOIC	D	14	58	Green (RoHS & no Sb/Br)	CU NIPDAU	Level-3-260C-168 HR

<sup>(1)</sup> The marketing status values are defined as follows:

**ACTIVE:** Product device recommended for new designs.

**LIFEBUY:** TI has announced that the device will be discontinued, and a lifetime-buy period is in effect.

**NRND:** Not recommended for new designs. Device is in production to support existing customers, but TI does not recommend using this part in a new design.

**PREVIEW:** Device has been announced but is not in production. Samples may or may not be available.

**OBSOLETE:** TI has discontinued the production of the device.

<sup>(2)</sup> Eco Plan - The planned eco-friendly classification: Pb-Free (RoHS), Pb-Free (RoHS Exempt), or Green (RoHS & no Sb/Br) - please check <http://www.ti.com/productcontent> for the latest availability information and additional product content details.

**TBD:** The Pb-Free/Green conversion plan has not been defined.

**Pb-Free (RoHS):** TI's terms "Lead-Free" or "Pb-Free" mean semiconductor products that are compatible with the current RoHS requirements for all 6 substances, including the requirement that lead not exceed 0.1% by weight in homogeneous materials. Where designed to be soldered at high temperatures, TI Pb-Free products are suitable for use in specified lead-free processes.

**Pb-Free (RoHS Exempt):** This component has a RoHS exemption for either 1) lead-based flip-chip solder bumps used between the die and package, or 2) lead-based die adhesive used between the die and leadframe. The component is otherwise considered Pb-Free (RoHS compatible) as defined above.

**Green (RoHS & no Sb/Br):** TI defines "Green" to mean Pb-Free (RoHS compatible), and free of Bromine (Br) and Antimony (Sb) based flame retardants (Br or Sb do not exceed 0.1% by weight in homogeneous material)

<sup>(3)</sup> MSL, Peak Temp. -- The Moisture Sensitivity Level rating according to the JEDEC industry standard classifications, and peak solder temperature.

**Important Information and Disclaimer:** The information provided on this page represents TI's knowledge and belief as of the date that it is provided. TI bases its knowledge and belief on information provided by third parties, and makes no representation or warranty as to the accuracy of such information. Efforts are underway to better integrate information from third parties. TI has taken and continues to take reasonable steps to provide representative and accurate information but may not have conducted destructive testing or chemical analysis on incoming materials and chemicals. TI and TI suppliers consider certain information to be proprietary, and thus CAS numbers and other limited information may not be available for release.

In no event shall TI's liability arising out of such information exceed the total purchase price of the TI part(s) at issue in this document sold by TI to Customer on an annual basis.

**TAPE AND REEL INFORMATION**



**QUADRANT ASSIGNMENTS FOR PIN 1 ORIENTATION IN TAPE**



\*All dimensions are nominal

Device	Package Type	Package Drawing	Pins	SPQ	Reel Diameter (mm)	Reel Width W1 (mm)	A0 (mm)	B0 (mm)	K0 (mm)	P1 (mm)	W (mm)	Pin1 Quadrant
INA2132UA/2K5	SOIC	D	14	2500	330.0	16.4	6.5	9.0	2.1	8.0	16.0	Q1

**TAPE AND REEL BOX DIMENSIONS**

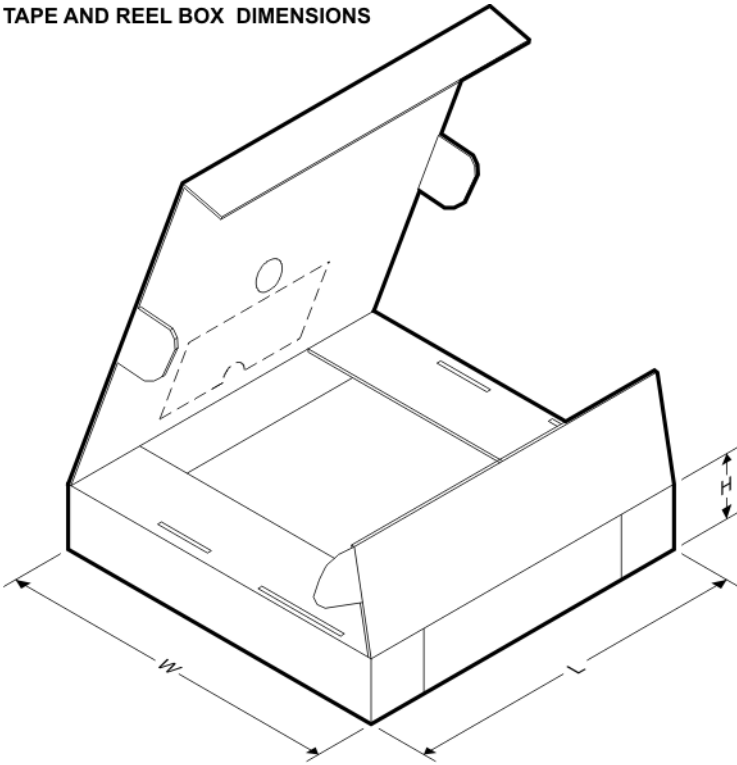

\*All dimensions are nominal

Device	Package Type	Package Drawing	Pins	SPQ	Length (mm)	Width (mm)	Height (mm)
INA2132UA/2K5	SOIC	D	14	2500	346.0	346.0	33.0

## IMPORTANT NOTICE

Texas Instruments Incorporated and its subsidiaries (TI) reserve the right to make corrections, modifications, enhancements, improvements, and other changes to its products and services at any time and to discontinue any product or service without notice. Customers should obtain the latest relevant information before placing orders and should verify that such information is current and complete. All products are sold subject to TI's terms and conditions of sale supplied at the time of order acknowledgment.

TI warrants performance of its hardware products to the specifications applicable at the time of sale in accordance with TI's standard warranty. Testing and other quality control techniques are used to the extent TI deems necessary to support this warranty. Except where mandated by government requirements, testing of all parameters of each product is not necessarily performed.

TI assumes no liability for applications assistance or customer product design. Customers are responsible for their products and applications using TI components. To minimize the risks associated with customer products and applications, customers should provide adequate design and operating safeguards.

TI does not warrant or represent that any license, either express or implied, is granted under any TI patent right, copyright, mask work right, or other TI intellectual property right relating to any combination, machine, or process in which TI products or services are used. Information published by TI regarding third-party products or services does not constitute a license from TI to use such products or services or a warranty or endorsement thereof. Use of such information may require a license from a third party under the patents or other intellectual property of the third party, or a license from TI under the patents or other intellectual property of TI.

Reproduction of TI information in TI data books or data sheets is permissible only if reproduction is without alteration and is accompanied by all associated warranties, conditions, limitations, and notices. Reproduction of this information with alteration is an unfair and deceptive business practice. TI is not responsible or liable for such altered documentation. Information of third parties may be subject to additional restrictions.

Resale of TI products or services with statements different from or beyond the parameters stated by TI for that product or service voids all express and any implied warranties for the associated TI product or service and is an unfair and deceptive business practice. TI is not responsible or liable for any such statements.

TI products are not authorized for use in safety-critical applications (such as life support) where a failure of the TI product would reasonably be expected to cause severe personal injury or death, unless officers of the parties have executed an agreement specifically governing such use. Buyers represent that they have all necessary expertise in the safety and regulatory ramifications of their applications, and acknowledge and agree that they are solely responsible for all legal, regulatory and safety-related requirements concerning their products and any use of TI products in such safety-critical applications, notwithstanding any applications-related information or support that may be provided by TI. Further, Buyers must fully indemnify TI and its representatives against any damages arising out of the use of TI products in such safety-critical applications.

TI products are neither designed nor intended for use in military/aerospace applications or environments unless the TI products are specifically designated by TI as military-grade or "enhanced plastic." Only products designated by TI as military-grade meet military specifications. Buyers acknowledge and agree that any such use of TI products which TI has not designated as military-grade is solely at the Buyer's risk, and that they are solely responsible for compliance with all legal and regulatory requirements in connection with such use.

TI products are neither designed nor intended for use in automotive applications or environments unless the specific TI products are designated by TI as compliant with ISO/TS 16949 requirements. Buyers acknowledge and agree that, if they use any non-designated products in automotive applications, TI will not be responsible for any failure to meet such requirements.

Following are URLs where you can obtain information on other Texas Instruments products and application solutions:

### Products

Amplifiers	<a href="http://amplifier.ti.com">amplifier.ti.com</a>
Data Converters	<a href="http://dataconverter.ti.com">dataconverter.ti.com</a>
DSP	<a href="http://dsp.ti.com">dsp.ti.com</a>
Clocks and Timers	<a href="http://www.ti.com/clocks">www.ti.com/clocks</a>
Interface	<a href="http://interface.ti.com">interface.ti.com</a>
Logic	<a href="http://logic.ti.com">logic.ti.com</a>
Power Mgmt	<a href="http://power.ti.com">power.ti.com</a>
Microcontrollers	<a href="http://microcontroller.ti.com">microcontroller.ti.com</a>
RFID	<a href="http://www.ti-rfid.com">www.ti-rfid.com</a>
RF/IF and ZigBee® Solutions	<a href="http://www.ti.com/lprf">www.ti.com/lprf</a>

### Applications

Audio	<a href="http://www.ti.com/audio">www.ti.com/audio</a>
Automotive	<a href="http://www.ti.com/automotive">www.ti.com/automotive</a>
Broadband	<a href="http://www.ti.com/broadband">www.ti.com/broadband</a>
Digital Control	<a href="http://www.ti.com/digitalcontrol">www.ti.com/digitalcontrol</a>
Medical	<a href="http://www.ti.com/medical">www.ti.com/medical</a>
Military	<a href="http://www.ti.com/military">www.ti.com/military</a>
Optical Networking	<a href="http://www.ti.com/opticalnetwork">www.ti.com/opticalnetwork</a>
Security	<a href="http://www.ti.com/security">www.ti.com/security</a>
Telephony	<a href="http://www.ti.com/telephony">www.ti.com/telephony</a>
Video & Imaging	<a href="http://www.ti.com/video">www.ti.com/video</a>
Wireless	<a href="http://www.ti.com/wireless">www.ti.com/wireless</a>

Mailing Address: Texas Instruments, Post Office Box 655303, Dallas, Texas 75265  
Copyright © 2008, Texas Instruments Incorporated