

Distributed by:

**JAMECO**<sup>®</sup>  
ELECTRONICS

**www.Jameco.com ♦ 1-800-831-4242**

The content and copyrights of the attached  
material are the property of its owner.

Jameco Part Number 901386



For most current data sheet and other product information, visit [www.burr-brown.com](http://www.burr-brown.com)

## High-Voltage, Programmable Gain DIFFERENCE AMPLIFIER

### FEATURES

- **HIGH COMMON-MODE VOLTAGE:**  
+40V at  $V_S = +5V$   
 $\pm 100V$  at  $V_S = \pm 15V$
- **DIFFERENTIAL GAIN = 0.1V/V TO 100V/V:**  
Set with External Resistors
- **LOW QUIESCENT CURRENT: 570 $\mu$ A**
- **WIDE SUPPLY RANGE:**  
Single Supply: 4.5V to 36V  
Dual Supplies:  $\pm 2.25V$  to  $\pm 18V$
- **LOW GAIN ERROR: 0.025%**
- **HIGH CMR: 80dB**
- **SO-8 PACKAGE**

### APPLICATIONS

- **CURRENT SHUNT MEASUREMENTS**
- **SENSOR AMPLIFIER**
- **SYNCHRONOUS DEMODULATOR**
- **CURRENT AND DIFFERENTIAL LINE RECEIVER**
- **VOLTAGE-CONTROLLED CURRENT SOURCE**
- **BATTERY POWERED SYSTEMS**
- **LOW COST AUTOMOTIVE INSTRUMENTATION**

### DESCRIPTION

The INA146 is a precision difference amplifier that can be used to accurately attenuate high differential voltages and reject high common-mode voltages for compatibility with common signal processing voltage levels. High-voltage capability also affords inherent input protection. The input common-mode range extends beyond both supply rails, making the INA146 well-suited for both single and dual supply applications.

On-chip precision resistors are laser-trimmed to achieve accurate gain and high common-mode rejection. Excellent TCR tracking of these resistors assures continued high precision over temperature.

A 10:1 difference amplifier provides 0.1V/V gain when the output amplifier is used as a unity-gain buffer. In this configuration, input voltages up to  $\pm 100V$  can be measured. Gains greater than 0.1V/V can be set with an external resistor pair without affecting the common-mode input range.

The INA146 is available in the SO-8 surface-mount package specified for the extended industrial temperature range,  $-40^{\circ}C$  to  $+85^{\circ}C$ .

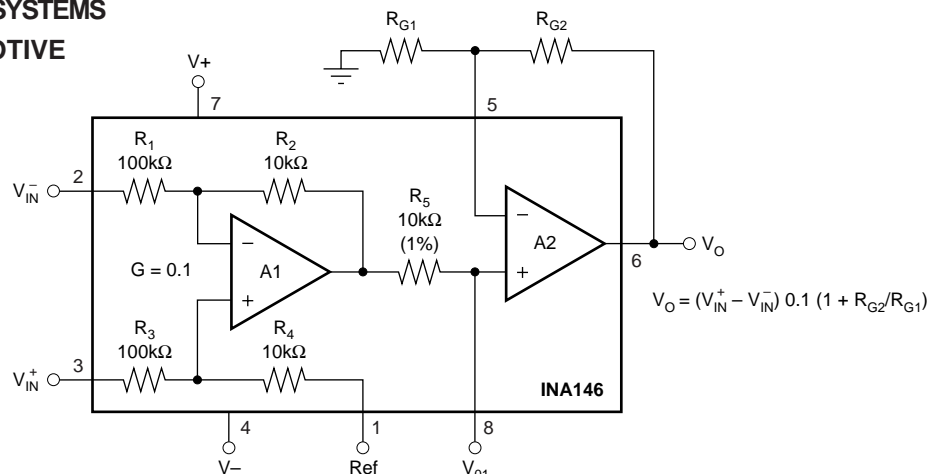

# SPECIFICATIONS: $V_S = \pm 2.25V$ to $\pm 18V$ Dual Supplies

At  $T_A = +25^\circ C$ ,  $G = 0.1$ ,  $R_L = 10k\Omega$  connected to ground and ref pin connected to ground unless otherwise noted.

**Boldface** limits apply over the specified temperature range,  $T_A = -40^\circ C$  to  $+85^\circ C$ .

PARAMETER	CONDITION	INA146UA			UNITS
		MIN	TYP	MAX	
<b>OFFSET VOLTAGE, <math>V_O</math></b> Input Offset Voltage <b>vs Temperature</b> vs Power Supply vs Time Offset Voltage, $V_{O1}$	$RTI^{(1, 2)}$ $V_S = \pm 15, V_{CM} = V_O = 0V$		$\pm 1$	$\pm 5$	mV
	$V_{OS}$ $\Delta V_{OS}/\Delta T$ PSRR $V_S = \pm 1.35V$ to $\pm 18V$		<b>See Typical Curve</b>		$\mu V/V$ $\mu V/mo$ mV
<b>INPUT VOLTAGE RANGE</b> Common-Mode Voltage Range Common-Mode Rejection <b>Over Temperature</b>	$(V_{IN+}) - (V_{IN-}) = 0V, V_O = 0V$ $V_{CM} = 11 (V-) \text{ to } 11 (V+) = 11, R_S = 0\Omega$			$\pm 100^{(3)}$	V dB dB
	$V_{CM}$ CMRR	70 <b>64</b>	80 <b>74</b>		
<b>INPUT BIAS CURRENT<sup>(2)</sup></b> Bias Current Offset Current	$V_{CM} = V_S/2$		$\pm 50$		nA nA
		$I_B$ $I_{OS}$		$\pm 5$	
<b>INPUT IMPEDANCE</b> Differential (non-inverting input) Differential (inverting input) Common-Mode			110 91.7 55		k $\Omega$ k $\Omega$ k $\Omega$
	<b>NOISE</b> Voltage Noise, $f = 0.1Hz$ to $10Hz$ Voltage Noise Density, $f = 1kHz$	$RTI^{(1, 4)}$		10 550	$\mu Vp-p$ nV/ $\sqrt{Hz}$
	$e_n$				
<b>GAIN</b> Gain Equation Initial <sup>(1)</sup> Gain Error <b>vs Temperature</b> <b>vs Temperature</b> Nonlinearity	$R_L = 100k\Omega, V_O = (V-)+0.15$ to $(V+)-1, G = 1$ <b><math>R_L = 100k\Omega, V_O = (V-)+0.25</math> to <math>(V+)-1, G = 1</math></b> $R_L = 10k\Omega, V_O = (V-)+0.3$ to $(V+)-1.25, G = 1$ <b><math>R_L = 10k\Omega, V_O = (V-)+0.5</math> to <math>(V+)-1.25, G = 1</math></b> $V_O = (V-)+0.3$ to $(V+)-1.25, G = 1$	$G = 0.1$ to $100$ $G = 0.1 \cdot (1 + R_{G2}/R_{G1})$			V/V V/V % % % % of FS
		0.1	$\pm 0.025$	$\pm 0.1$	
		$\pm 1$	$\pm 0.025$	$\pm 0.1$	
		$\pm 1$	$\pm 10$	$\pm 10$	
		$\pm 0.001$	$\pm 0.001$	$\pm 0.01$	
<b>FREQUENCY RESPONSE</b> Small Signal Bandwidth  Slew Rate Settling Time, 0.1% 0.01% Overload Recovery	$G = 0.1$ $G = 1$  $G = 1, 10V$ Step $G = 1, 10V$ Step 50% Input Overload		550 50 0.45 40 80 40		kHz kHz V/ $\mu s$ $\mu s$ $\mu s$ $\mu s$
<b>OUTPUT, <math>V_O</math></b> Voltage Output <b>Over Temperature</b>  <b>Over Temperature</b> Short-Circuit Current Capacitive Load	$R_L = 100k\Omega, G = 1$ <b><math>R_L = 100k\Omega, G = 1</math></b> $R_L = 10k\Omega, G = 1$ <b><math>R_L = 10k\Omega, G = 1</math></b> Continuous to Common Stable Operation	$(V-) + 0.15$ <b><math>(V-) + 0.25</math></b> $(V-) + 0.3$ <b><math>(V-) + 0.5</math></b>		$(V+) - 1$ <b><math>(V+) - 1</math></b> $(V+) - 1.25$ <b><math>(V+) - 1.25</math></b>	V V V V mA pF
			$\pm 15$ 1000		
<b>POWER SUPPLY</b> Specified Voltage Range, Dual Supplies Operating Voltage Range Quiescent Current <b>Over Temperature</b>	$V_{IN} = 0, I_O = 0$	$\pm 2.25$ $\pm 1.35$		$\pm 18$ $\pm 18$ $\pm 700$ <b><math>\pm 750</math></b>	V V $\mu A$ $\mu A$
			$\pm 570$		
<b>TEMPERATURE RANGE</b> Specified Range Operating Range Storage Range Thermal Resistance			-40 -55 -55	+85 +125 +125	$^\circ C$ $^\circ C$ $^\circ C$ $^\circ C/W$
				150	

NOTES: (1) Overall difference amplifier configuration. Referred to input pins ( $V_{IN+}$  and  $V_{IN-}$ ), gain = 0.1V/V. Specified with 10k $\Omega$  in feedback of A2. (2) Input offset voltage specification includes effects of amplifier's input bias and offset currents. (3) Common-mode voltage range is 11 (V-) to 11 [(V+) - 1] with a maximum of  $\pm 100V$ . (4) Includes effects of input current noise and thermal noise contribution of resistor network.

The information provided herein is believed to be reliable; however, BURR-BROWN assumes no responsibility for inaccuracies or omissions. BURR-BROWN assumes no responsibility for the use of this information, and all use of such information shall be entirely at the user's own risk. Prices and specifications are subject to change without notice. No patent rights or licenses to any of the circuits described herein are implied or granted to any third party. BURR-BROWN does not authorize or warrant any BURR-BROWN product for use in life support devices and/or systems.

# SPECIFICATIONS: $V_S = +5V$ Single Supply

At  $T_A = +25^\circ\text{C}$ ,  $G = 1$ ,  $R_L = 10\text{k}\Omega$  connected to  $V_S/2$  and Ref pin connected to  $V_S/2$  unless otherwise noted.

**Boldface** limits apply over the specified temperature range,  $T_A = -40^\circ\text{C}$  to  $+85^\circ\text{C}$ .

PARAMETER	CONDITION	INA146UA			UNITS
		MIN	TYP	MAX	
<b>OFFSET VOLTAGE, <math>V_O</math></b> Input Offset Voltage $V_{OS}$ <b>vs Temperature</b> $\Delta V_{OS}/\Delta T$ vs Power Supply Rejection Ratio PSRR vs Time	RTI <sup>(1, 2)</sup> $V_{CM} = V_O = 0V$  $V_S = \pm 1.35V$ to $\pm 18V$		$\pm 3$ <b>See Typical Curve</b> $\pm 100$ $\pm 3$	$\pm 10$  $\pm 600$	mV  $\mu\text{V}/^\circ\text{C}$ $\mu\text{V}/\text{mo}$
<b>INPUT VOLTAGE RANGE</b> Common-Mode Voltage Range $V_{CM}$ Common-Mode Rejection Ratio CMRR <b>Over Temperature</b>	$V_{IN+} - V_{IN-} = 0V$ , $V_O = 0V$ $V_{CM} = -25V$ to $+19V$ , $R_S = 0\Omega$	-25 70 <b>64</b>	80 <b>74</b>	19	V dB dB
<b>INPUT BIAS CURRENT<sup>(2)</sup></b> Bias Current $I_B$ Offset Current $I_{OS}$			$\pm 50$ $\pm 5$		nA nA
<b>INPUT IMPEDANCE</b> Differential (non-inverting input) Differential (inverting input) Common-Mode			110 91.7 55		k $\Omega$ k $\Omega$ k $\Omega$
<b>NOISE</b> Voltage Noise, $f = 0.1\text{Hz}$ to $10\text{Hz}$ Voltage Noise Density, $f = 1\text{kHz}$ $e_n$	RTI <sup>(1, 3, 4)</sup>		10 550		$\mu\text{Vp-p}$ nV/ $\sqrt{\text{Hz}}$
<b>GAIN</b> Gain Equation Initial <sup>(1)</sup> Gain Error <b>vs Temperature</b>  <b>vs Temperature</b> Nonlinearity	$R_L = 100\text{k}\Omega$ , $V_O = 0.15V$ to $4V$ , $G = 1$ <b><math>R_L = 100\text{k}\Omega</math>, <math>V_O = 0.25V</math> to <math>4V</math>, <math>G = 1</math></b> $R_L = 10\text{k}\Omega$ , $V_O = 0.3V$ to $3.75V$ , $G = 1$ <b><math>R_L = 10\text{k}\Omega</math>, <math>V_O = 0.5V</math> to <math>3.75V</math>, <math>G = 1</math></b> $V_O = +0.3$ to $+3.75$ , $G = 1$		$G = 0.1$ to $100$ $G = 0.1 \cdot (1 + R_{G2}/R_{G1})$ 0.1 $\pm 0.025$ $\pm 1$ $\pm 0.025$ $\pm 1$ $\pm 0.001$	$\pm 0.1$ <b><math>\pm 10</math></b> $\pm 0.1$ <b><math>\pm 10</math></b> $\pm 0.01$	V/V V/V V/V % ppm/ $^\circ\text{C}$ % ppm/ $^\circ\text{C}$ % of FS
<b>FREQUENCY RESPONSE</b> Small Signal Bandwidth  Slew Rate Settling Time, 0.1% 0.01% Overload Recovery	$G = 0.1$ $G = 1$  $G = 1$ , 10V Step $G = 1$ , 10V Step 50% Input Overload		550 50 0.45 40 80 40		kHz kHz V/ $\mu\text{s}$ $\mu\text{s}$ $\mu\text{s}$ $\mu\text{s}$
<b>OUTPUT, <math>V_O</math></b> Voltage Output <b>Over Temperature</b>  <b>Over Temperature</b> Short-Circuit Current Capacitive Load	$R_L = 100\text{k}\Omega$ , $G = 1$ <b><math>R_L = 100\text{k}\Omega</math>, <math>G = 1</math></b> $R_L = 10\text{k}\Omega$ , $G = 1$ <b><math>R_L = 10\text{k}\Omega</math>, <math>G = 1</math></b> Continuous to Common Stable Operation	0.15 <b>0.25</b> 0.3 <b>0.5</b>		4 <b>4</b> 3.75 <b>3.75</b> $\pm 15$ 1000	V V V V mA pF
<b>POWER SUPPLY</b> Voltage Range, Dual Supplies Voltage Range, Single Supply Quiescent Current <b>Over Temperature</b>	$V_{IN} = 0$ , $I_O = 0$	$\pm 2.25$ $\pm 4.5$		$\pm 18$ $\pm 36$ $\pm 700$ <b><math>\pm 750</math></b>	V V $\mu\text{A}$ $\mu\text{A}$
<b>TEMPERATURE RANGE</b> Specified Range Operating Range Storage Range Thermal Resistance $\theta_{JA}$		-40 -55 -55		+85 +125 +125	$^\circ\text{C}$ $^\circ\text{C}$ $^\circ\text{C}$ $^\circ\text{C}/\text{W}$

NOTES: (1) Overall difference amplifier configuration. Referred to input pins ( $V_{IN+}$  and  $V_{IN-}$ ), gain =  $0.1V/V$ . Specified with  $10\text{k}\Omega$  in feedback of A2. (2) Input offset voltage specification includes effects of amplifier's input bias and offset currents. (3) Includes effects of input current noise and thermal noise contribution of resistor network. (4) Common-mode voltage range is 11 (V-) to 11 [(V+) - 1] with a maximum of  $\pm 100V$ .

# AMPLIFIER A1, A2 PERFORMANCE

At  $T_A = +25^\circ\text{C}$ ,  $G = 0.1$ ,  $R_L = 10\text{k}\Omega$  connected to ground and Ref pin, unless otherwise noted.

**Boldface** limits apply over the specified temperature range,  $T_A = -40^\circ\text{C}$  to  $+85^\circ\text{C}$ .

PARAMETER	CONDITION	INA146UA			UNITS
		MIN	TYP	MAX	
<b>OFFSET VOLTAGE, <math>V_O</math></b> Input Offset Voltage <b>vs Temperature</b>	$V_{OS}$ $\Delta V_{OS}/\Delta T$ RTI <sup>(1,2)</sup> $V_S = \pm 15\text{V}$ , $V_{CM} = V_O = 0\text{V}$ $T_A = -40^\circ\text{C}$ to $+85^\circ\text{C}$		$\pm 0.5$ $\pm 1$		mV $\mu\text{V}/^\circ\text{C}$
<b>INPUT VOLTAGE RANGE</b> Common-Mode Voltage Range Common-Mode Rejection Ratio	$V_{IN+} - V_{IN-} = 0\text{V}$ , $V_O = 0\text{V}$ $V_{CM} = (V-) \text{ to } (V+) - 1$		$(V-) \text{ to } (V+) - 1$ 90		V dB
<b>OPEN-LOOP GAIN</b> Open Loop Gain	$A_{OL}$		110		dB
<b>INPUT BIAS CURRENT<sup>(2)</sup></b> Bias Current Offset Current	$I_B$ $I_{OS}$		$\pm 50$ $\pm 5$		nA nA
<b>RESISTOR AT A1 OUTPUT, <math>V_{O1}</math></b> Initial Error Temperature Drift Coefficient			10 $\pm 1$ $\pm 100$		k $\Omega$ % ppm/ $^\circ\text{C}$

## PIN CONFIGURATION

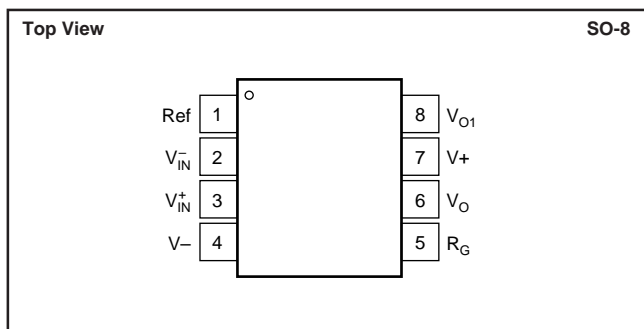

## ELECTROSTATIC DISCHARGE SENSITIVITY

This integrated circuit can be damaged by ESD. Burr-Brown recommends that all integrated circuits be handled with appropriate precautions. Failure to observe proper handling and installation procedures can cause damage.

ESD damage can range from subtle performance degradation to complete device failure. Precision integrated circuits may be more susceptible to damage because very small parametric changes could cause the device not to meet its published specifications.

## ABSOLUTE MAXIMUM RATINGS<sup>(1)</sup>

Supply Voltage, $V+$ to $V-$ .....	36V
Signal Input Terminals, Voltage .....	$\pm 100\text{V}$
Current .....	$\pm 1\text{mA}$
Output Short Circuit (to ground) .....	Continuous
Operating Temperature .....	$-55^\circ\text{C}$ to $+125^\circ\text{C}$
Storage Temperature .....	$-55^\circ\text{C}$ to $+150^\circ\text{C}$
Junction Temperature .....	$+150^\circ\text{C}$
Lead Temperature (soldering, 10s) .....	$+240^\circ\text{C}$

NOTE: (1) Stresses above these ratings may cause permanent damage. Exposure to absolute maximum conditions for extended periods may degrade device reliability.

## PACKAGE/ORDERING INFORMATION

PRODUCT	PACKAGE	PACKAGE DRAWING NUMBER(1)	SPECIFIED TEMPERATURE RANGE	PACKAGE MARKING	ORDERING NUMBER(2)	TRANSPORT MEDIA
INA146UA	SO-8	182	$-40^\circ\text{C}$ to $+85^\circ\text{C}$	INA146UA	INA146UA INA146UA/2K5	Rails Tape and Reel

NOTES: (1) For detailed drawing and dimension table, please see end of data sheet, or Appendix C of Burr-Brown IC Data Book, or visit the Burr-Brown web site at [www.burr-brown.com](http://www.burr-brown.com). (2) Models with a slash (/) are available only in Tape and Reel in the quantities indicated (e.g., /2K5 indicates 2500 devices per reel). Ordering 2500 pieces of "INA146UA/2K5" will get a single 2500-piece Tape and Reel. For detailed Tape and Reel mechanical information, refer to Appendix B of Burr-Brown IC Data Book.

# TYPICAL PERFORMANCE CURVES

At  $T_A = +25^\circ\text{C}$ ,  $V_S = \pm 15\text{V}$ ,  $G = 0.1$ ,  $R_L = 10\text{k}\Omega$  connected to ground and Ref pin connected to ground, unless otherwise noted.

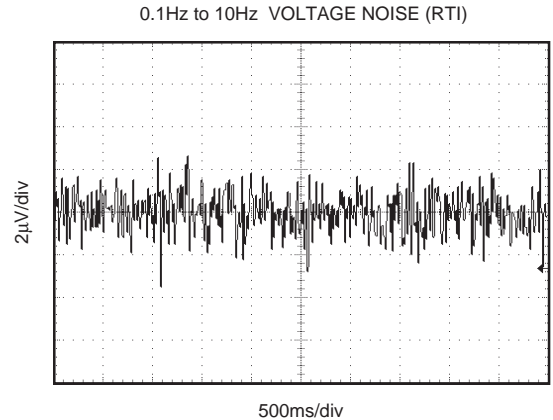
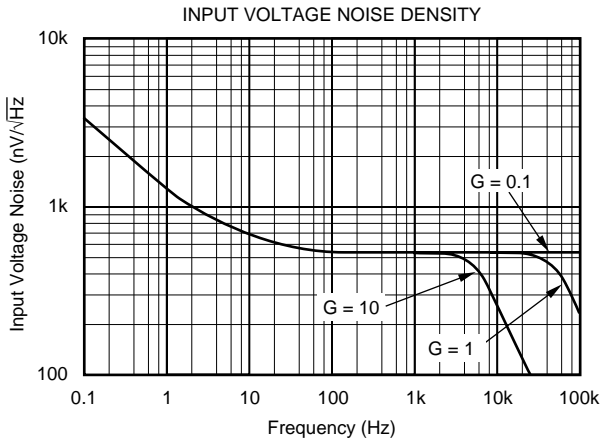
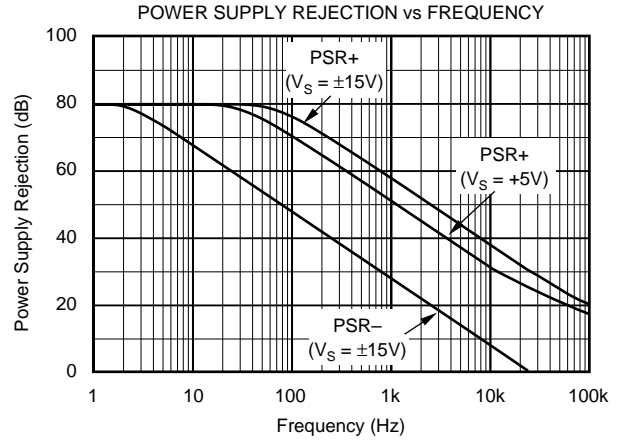
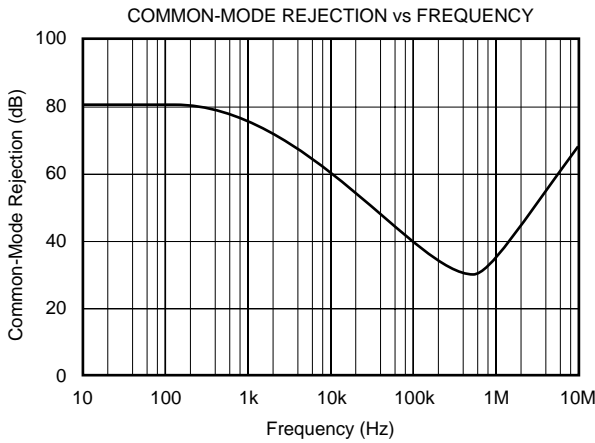
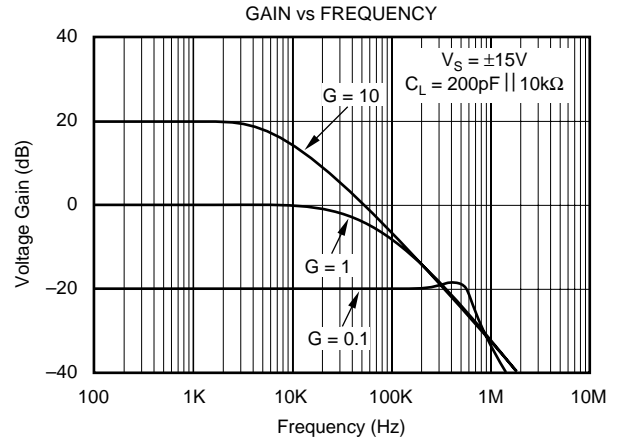
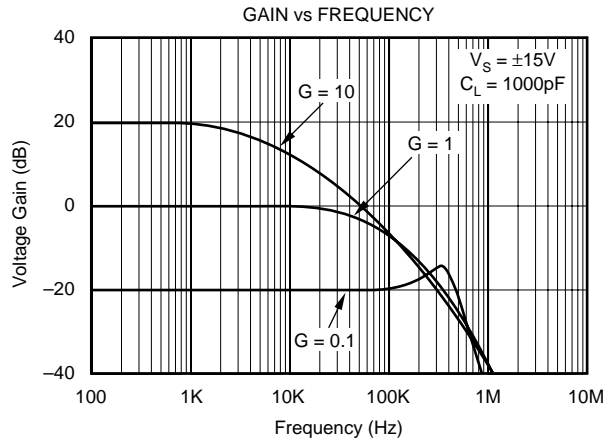

# TYPICAL PERFORMANCE CURVES (Cont.)

At  $T_A = +25^\circ\text{C}$ ,  $V_S = \pm 15\text{V}$ ,  $G = 0.1$ ,  $R_L = 10\text{k}\Omega$  connected to ground and Ref pin connected to ground, unless otherwise noted.

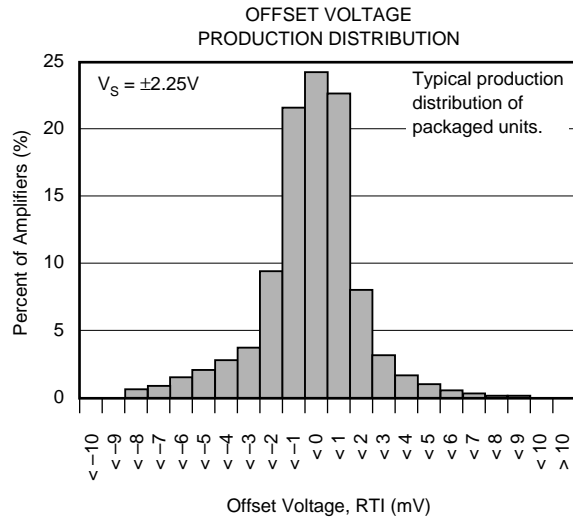
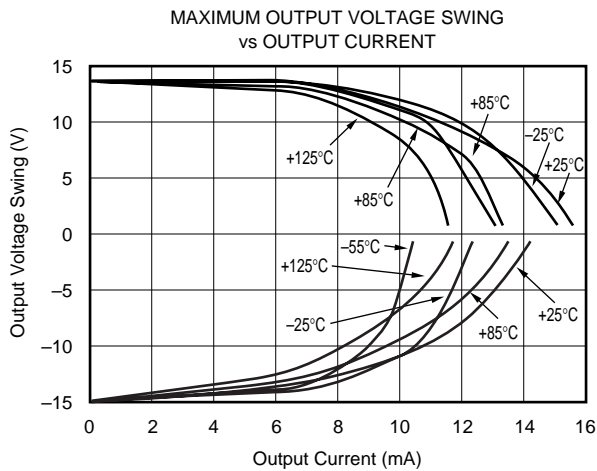
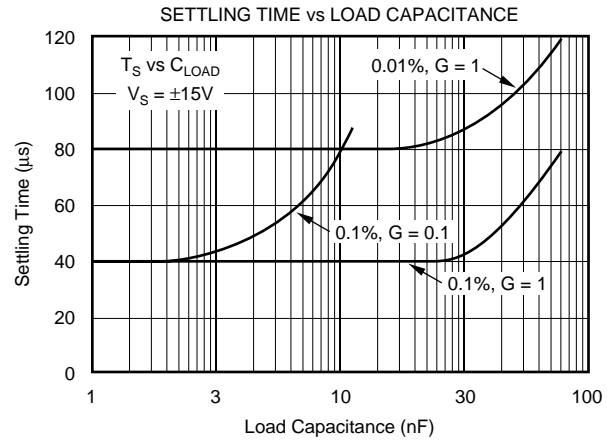
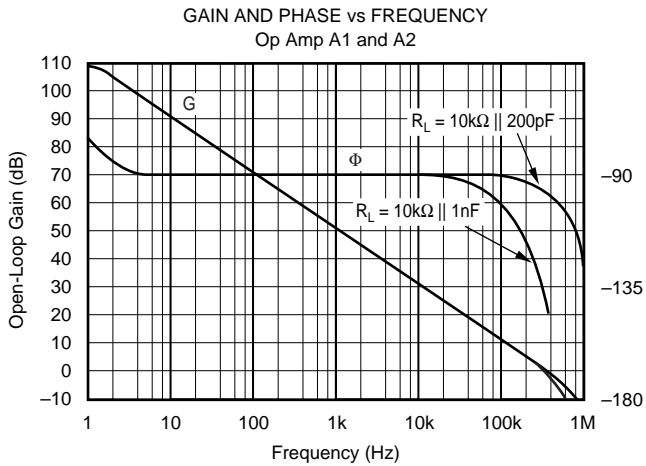
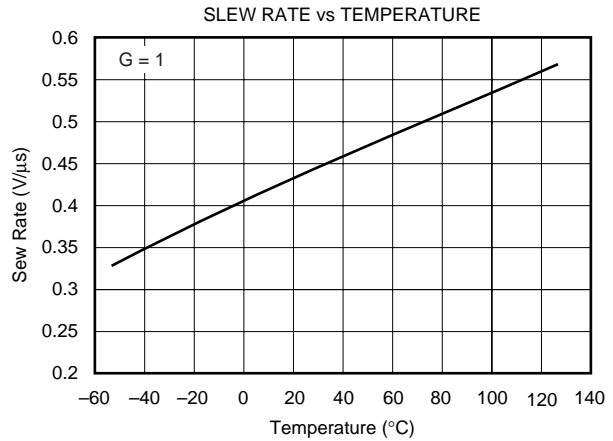
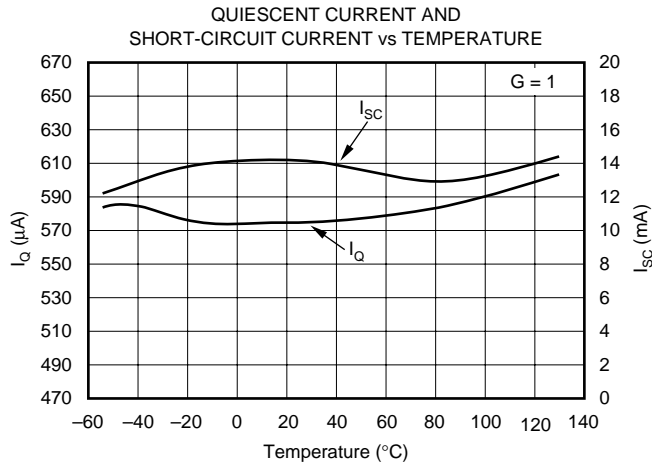

# TYPICAL PERFORMANCE CURVES (Cont.)

At  $T_A = +25^\circ\text{C}$ ,  $V_S = \pm 15\text{V}$ ,  $G = 0.1$ ,  $R_L = 10\text{k}\Omega$  connected to ground and Ref pin connected to ground, unless otherwise noted.

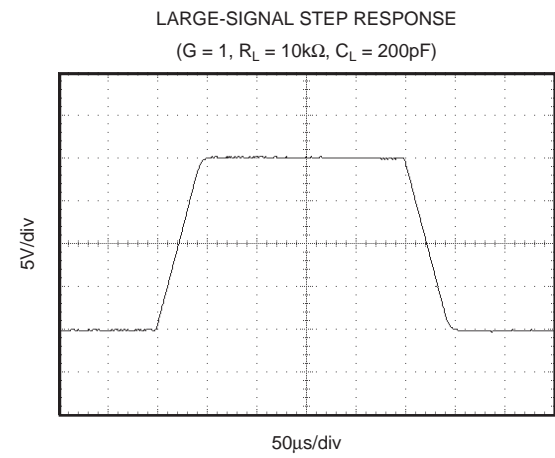
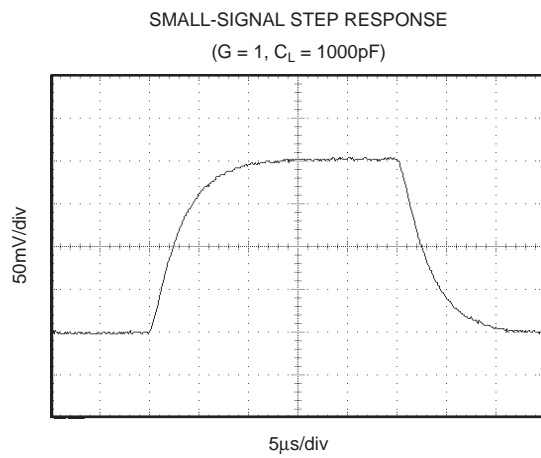
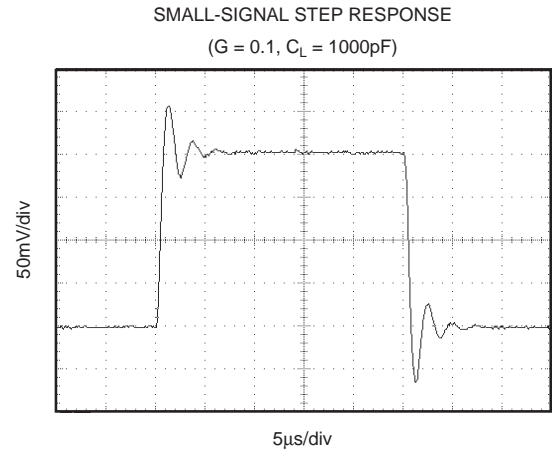
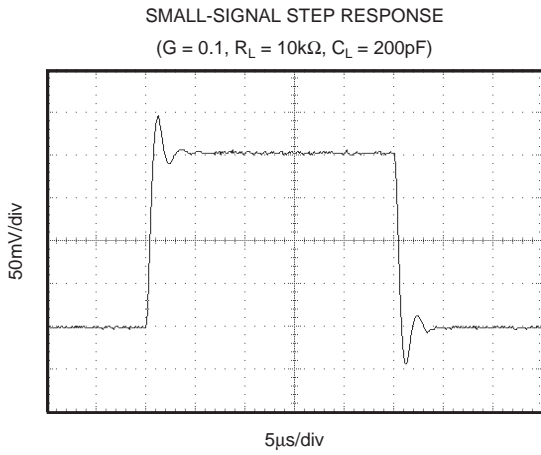
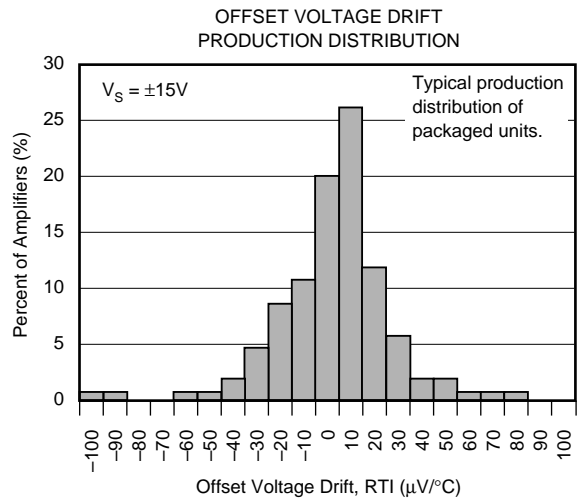
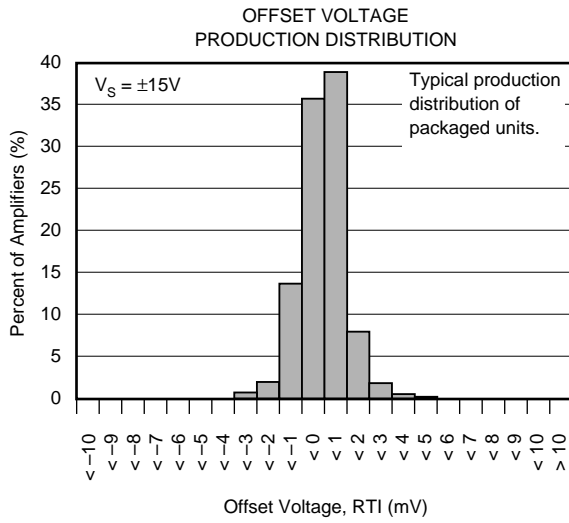

# APPLICATION INFORMATION

The INA146 is a programmable gain difference amplifier consisting of a gain of 0.1 difference amplifier and a programmable-gain output buffer stage. Basic circuit connections are shown in Figure 1. Power supply bypass capacitors should be connected close to pins 4 and 7 as shown. The amplifier is programmable in the range of  $G = 0.1$  to  $G = 50$  with two external resistors.

The output of A1 is connected to the noninverting input of A2 through a  $10k\Omega$  resistor which is trimmed to  $\pm 1\%$  absolute accuracy. The A2 input is available for applications such as a filter or a precision current source. See application figures for examples.

## OPERATING VOLTAGE

The INA146 is fully specified for supply voltages from  $\pm 2.25V$  to  $\pm 18V$  with key parameters guaranteed over the temperature range  $-40^\circ C$  to  $+85^\circ C$ . The INA146 can be operated with single or dual supplies with excellent performance. Parameters that vary significantly with operating voltage, load conditions or temperature are shown in the typical performance curves.

## SETTING THE GAIN

The gain of the INA146 is set by using two external resistors,  $R_{G1}$  and  $R_{G2}$ , according to the equation:

$$G = 0.1 \cdot (1 + R_{G2}/R_{G1})$$

For a total gain of 0.1, A2 is connected as a buffer amplifier with no  $R_{G1}$ . A feedback resistor,  $R_{G2} = 10k\Omega$ , should be used in the buffer connection. This provides bias current cancellation (in combination with internal  $R_5$ ) to assure specified offset voltage performance. Commonly used values are shown in the table of Figure 1. Resistor values for other gains should be chosen to provide a  $10k\Omega$  parallel resistance.

## COMMON-MODE RANGE

The 10:1 input resistor ratio of the INA146 provides an input common-mode range that can extend well beyond the power supply rails. Exact range depends on the power supply voltage and the voltage applied to the Ref terminal (pin 1). To assure proper operation, the voltage at the non-inverting input of A1 (an internal node) must be within its linear operating range. Its voltage is determined by the simple 10:1 voltage divider between pin 3 and pin 1. This voltage must be between  $V_-$  and  $(V_+) - 1V$ .

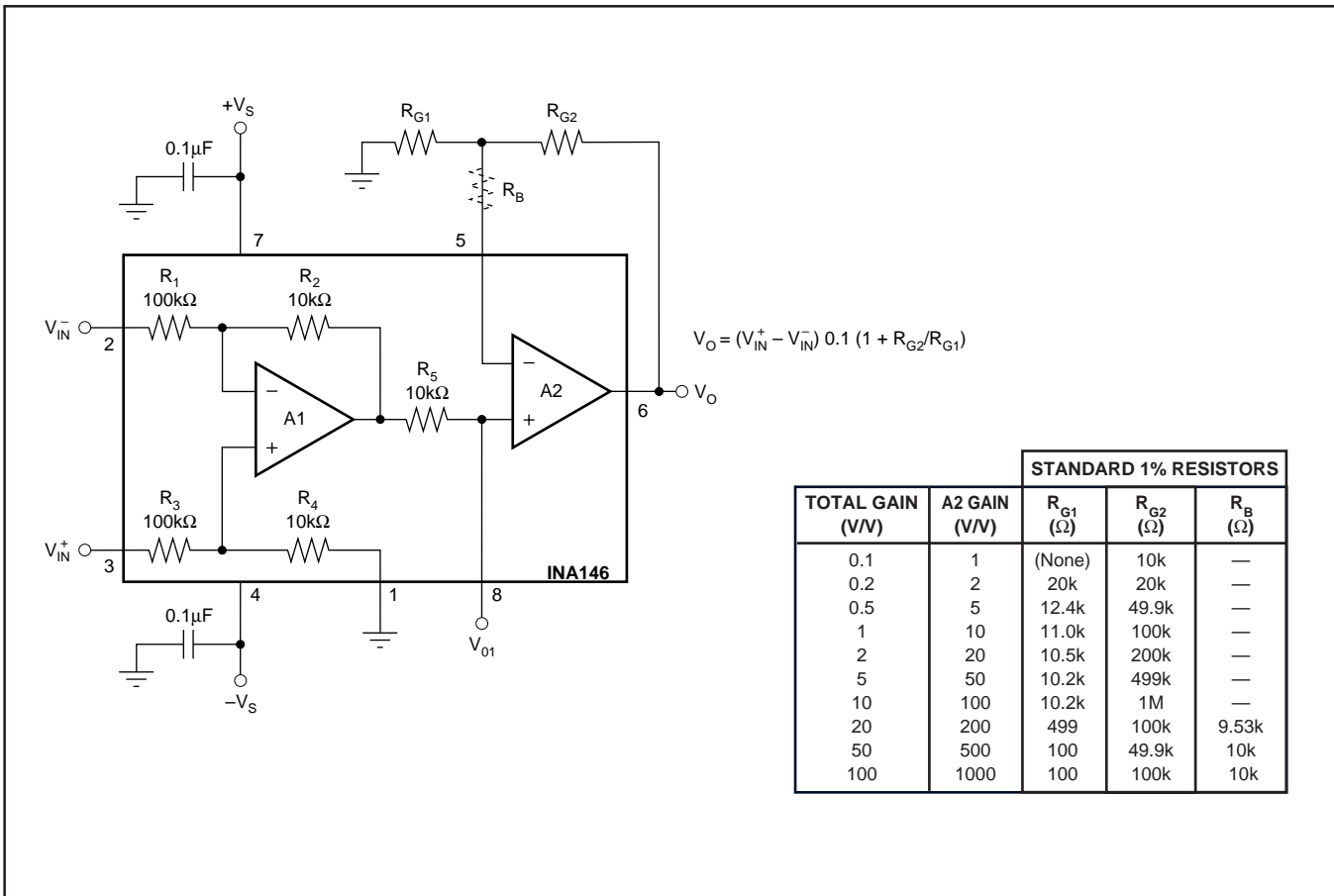

FIGURE 1. Basic Circuit Connections.

## OFFSET TRIM

The INA146 is laser-trimmed for low offset voltage and drift. Most applications require no external offset adjustment. Figure 2 shows an optional circuit for trimming the offset voltage. A voltage applied to the Ref terminal will be summed with the output signal. This can be used to null offset voltage. To maintain good common-mode rejection, the source impedance of a signal applied to the Ref terminal should be less than  $10\Omega$  and a resistor added to the positive input terminal should be 10 times that, or  $100\Omega$ . Alternatively, the trim voltage can be buffered with an op amp such as the OPA277.

## INPUT IMPEDANCE

The input impedance of the INA146 is determined by the input resistor network and is approximately  $100k\Omega$ . The source impedance at the two input terminals must be nearly equal to maintain good common-mode rejection. A  $12\Omega$  mismatch in impedance between the two inputs will cause the typical common-mode rejection to be degraded to approximately  $72\text{dB}$ . Figure 7 shows a common application measuring power supply current through a shunt resistor. The source impedance of the shunt resistor,  $R_S$ , is balanced by an equal compensation resistor,  $R_C$ .

Source impedances greater than  $800\Omega$  are not recommended, even if they are perfectly matched. Internal resistors are laser trimmed for accurate ratios, not to absolute values. Adding equal resistors greater than  $800\Omega$  can cause a mismatch in the total resistor ratios, degrading CMR.

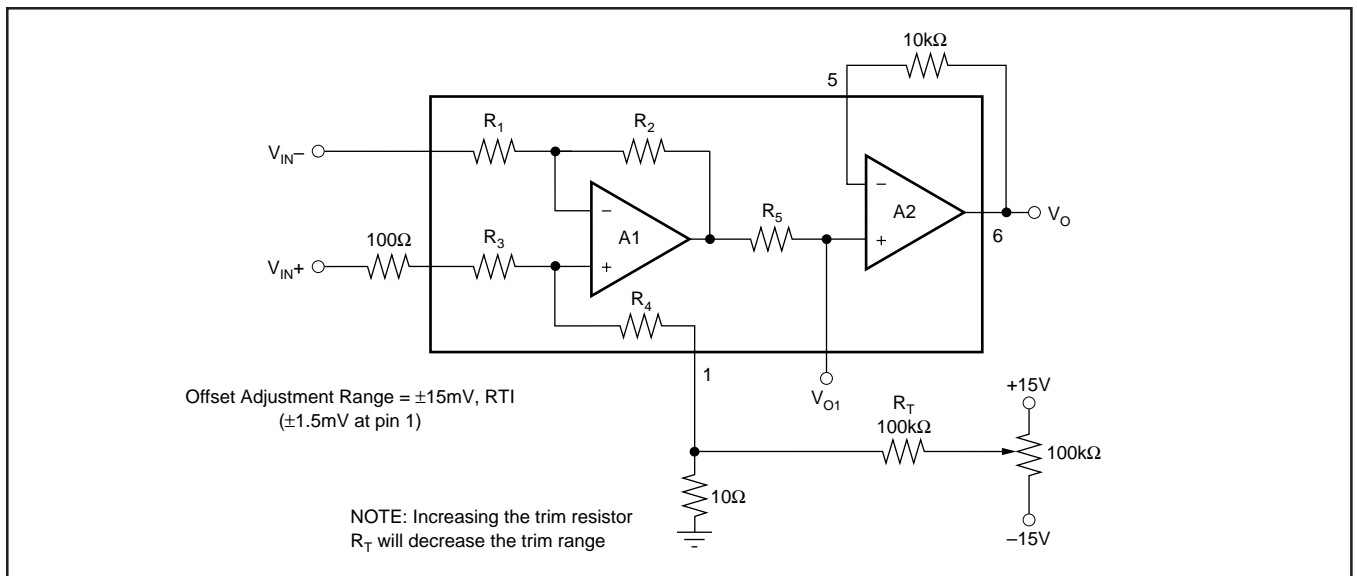

FIGURE 2. Optional Offset Trim Circuit.

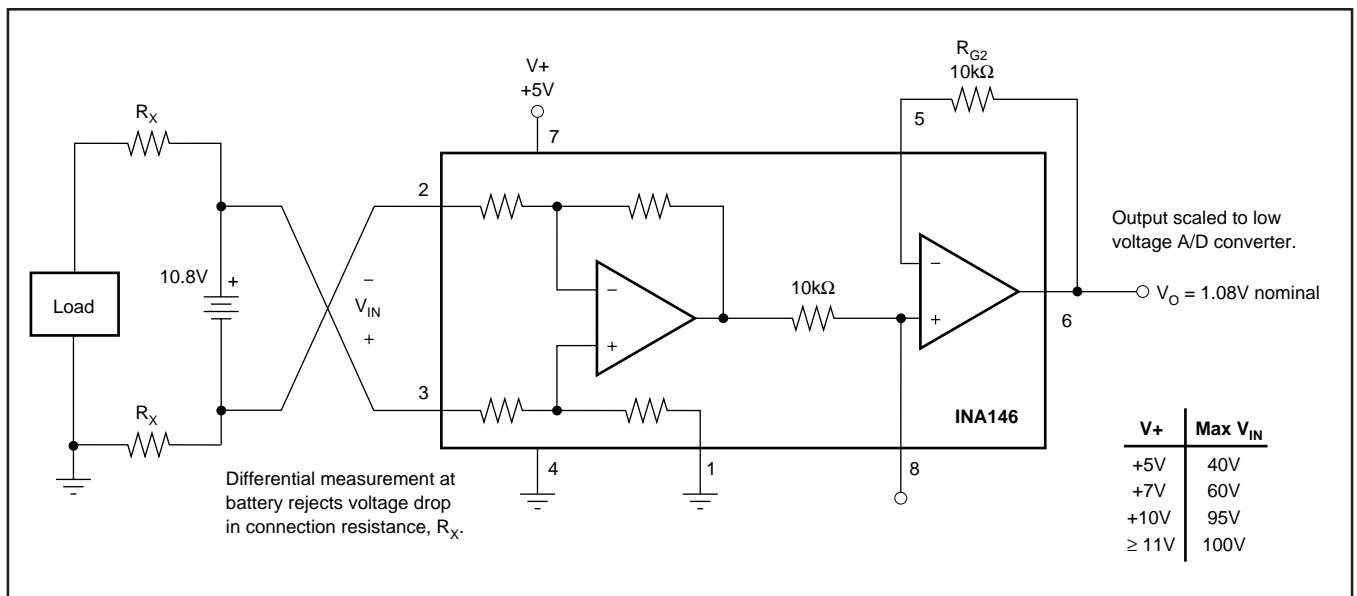

FIGURE 3. Measuring Voltages Greater than Supply Voltage.

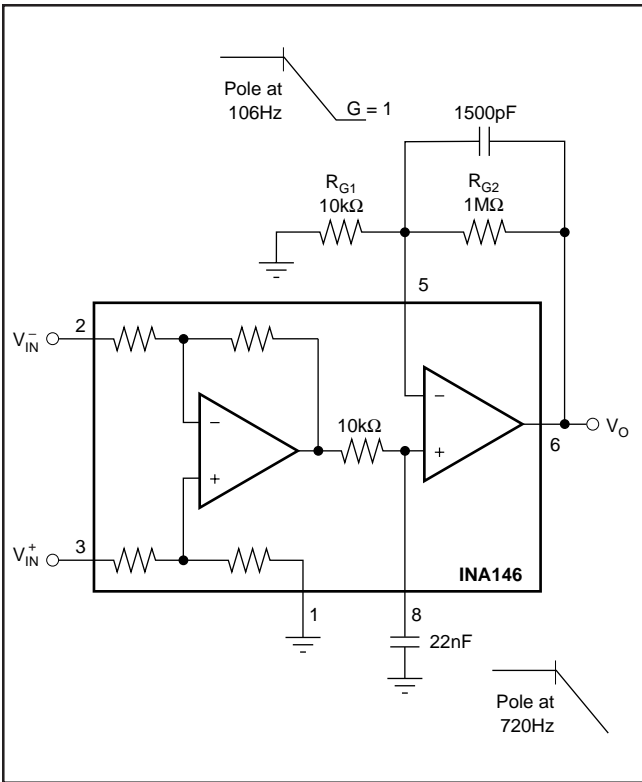

FIGURE 4. Noise Filtering.

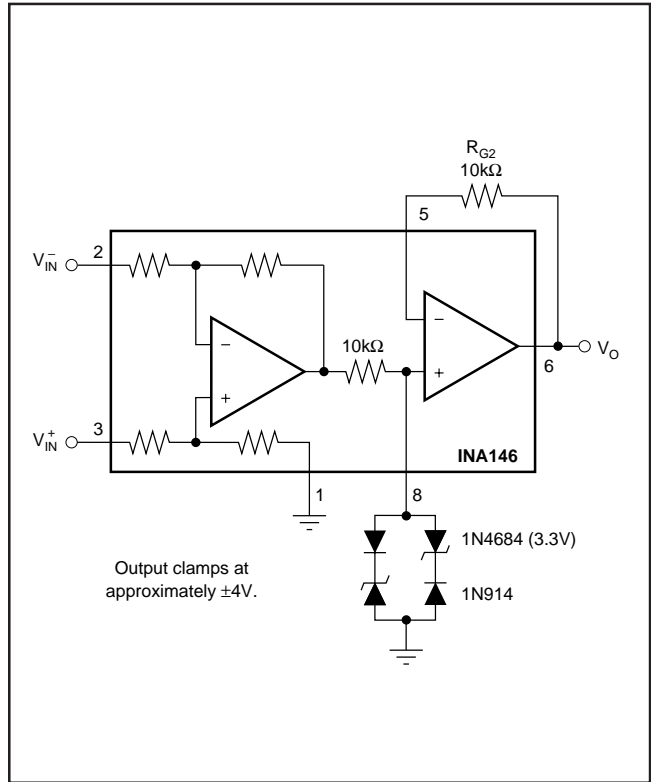

FIGURE 5. Output Clamp.

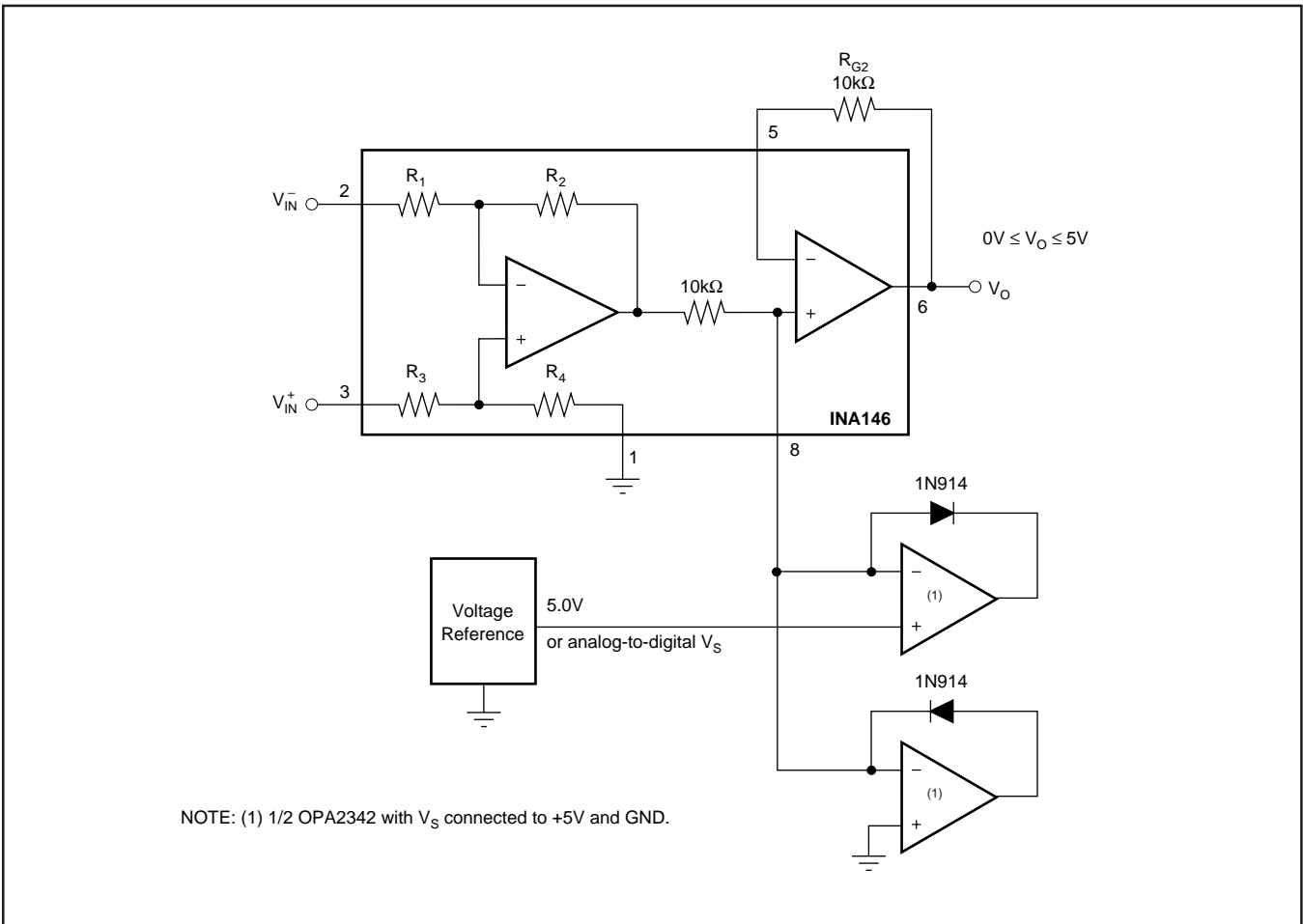

FIGURE 6. Precision Clamp.

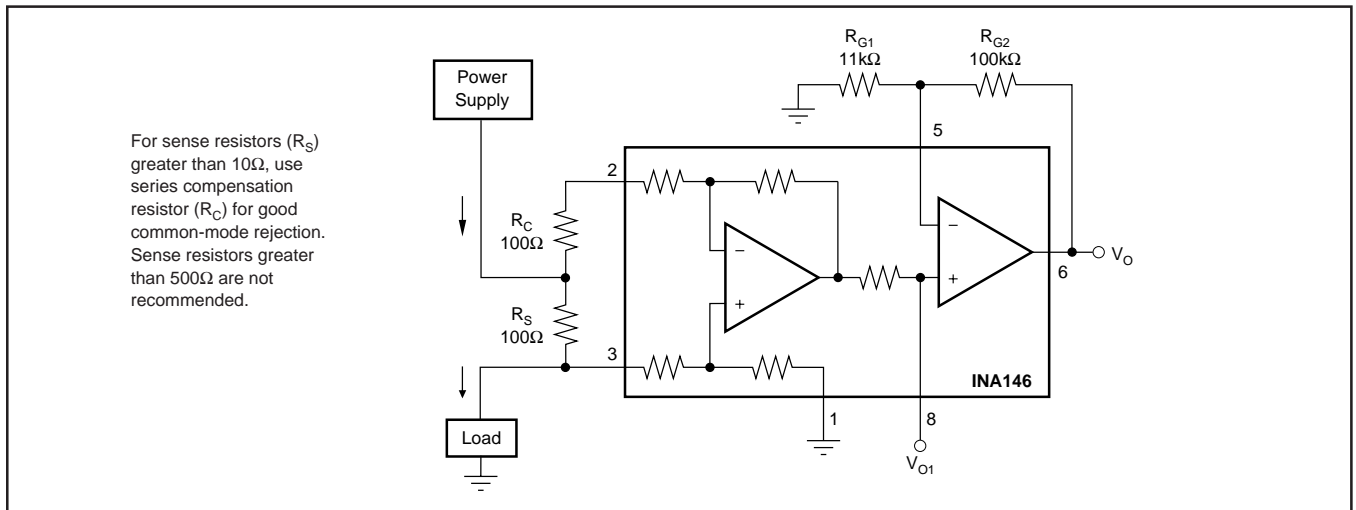

FIGURE 7. Current Monitor,  $G = 1$ .

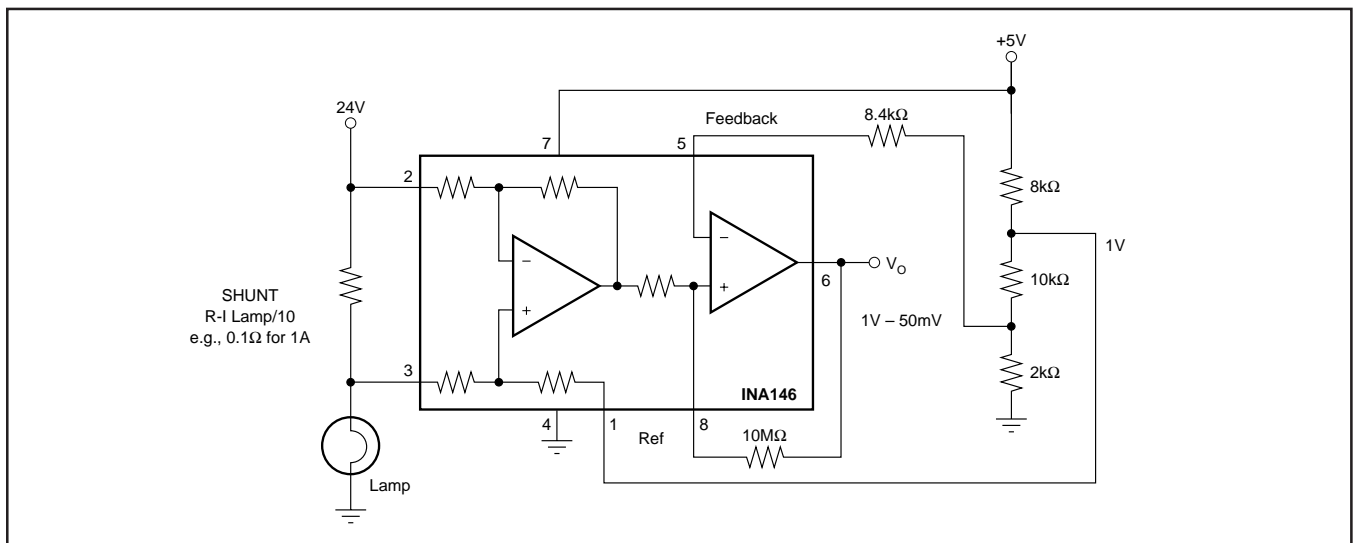

FIGURE 8. Comparator Output with Optional Hysteresis Application to Sense Lamp Burn-Out.

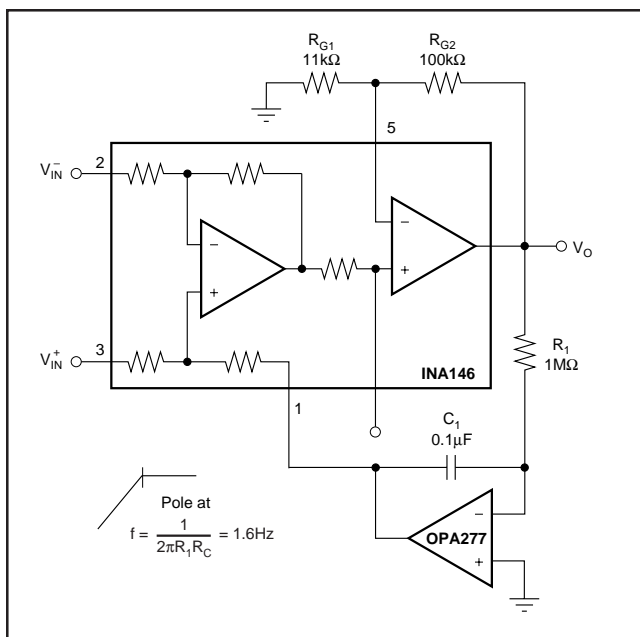

FIGURE 9. AC Coupling (DC Restoration).

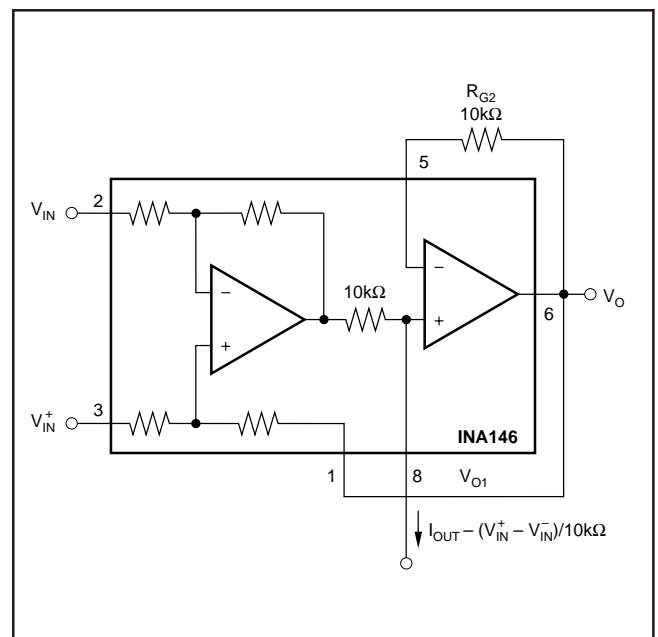

FIGURE 10. Precision Current Source.

**PACKAGING INFORMATION**

Orderable Device	Status <sup>(1)</sup>	Package Type	Package Drawing	Pins	Package Qty	Eco Plan <sup>(2)</sup>	Lead/Ball Finish	MSL Peak Temp <sup>(3)</sup>
INA146UA	ACTIVE	SOIC	D	8	100	Pb-Free (RoHS)	CU NIPDAU	Level-3-260C-168 HR
INA146UA/2K5	ACTIVE	SOIC	D	8	2500	Pb-Free (RoHS)	CU NIPDAU	Level-3-260C-168 HR

<sup>(1)</sup> The marketing status values are defined as follows:

**ACTIVE:** Product device recommended for new designs.

**LIFEBUY:** TI has announced that the device will be discontinued, and a lifetime-buy period is in effect.

**NRND:** Not recommended for new designs. Device is in production to support existing customers, but TI does not recommend using this part in a new design.

**PREVIEW:** Device has been announced but is not in production. Samples may or may not be available.

**OBsolete:** TI has discontinued the production of the device.

<sup>(2)</sup> Eco Plan - The planned eco-friendly classification: Pb-Free (RoHS), Pb-Free (RoHS Exempt), or Green (RoHS & no Sb/Br) - please check <http://www.ti.com/productcontent> for the latest availability information and additional product content details.

**TBD:** The Pb-Free/Green conversion plan has not been defined.

**Pb-Free (RoHS):** TI's terms "Lead-Free" or "Pb-Free" mean semiconductor products that are compatible with the current RoHS requirements for all 6 substances, including the requirement that lead not exceed 0.1% by weight in homogeneous materials. Where designed to be soldered at high temperatures, TI Pb-Free products are suitable for use in specified lead-free processes.

**Pb-Free (RoHS Exempt):** This component has a RoHS exemption for either 1) lead-based flip-chip solder bumps used between the die and package, or 2) lead-based die adhesive used between the die and leadframe. The component is otherwise considered Pb-Free (RoHS compatible) as defined above.

**Green (RoHS & no Sb/Br):** TI defines "Green" to mean Pb-Free (RoHS compatible), and free of Bromine (Br) and Antimony (Sb) based flame retardants (Br or Sb do not exceed 0.1% by weight in homogeneous material)

<sup>(3)</sup> MSL, Peak Temp. -- The Moisture Sensitivity Level rating according to the JEDEC industry standard classifications, and peak solder temperature.

**Important Information and Disclaimer:**The information provided on this page represents TI's knowledge and belief as of the date that it is provided. TI bases its knowledge and belief on information provided by third parties, and makes no representation or warranty as to the accuracy of such information. Efforts are underway to better integrate information from third parties. TI has taken and continues to take reasonable steps to provide representative and accurate information but may not have conducted destructive testing or chemical analysis on incoming materials and chemicals. TI and TI suppliers consider certain information to be proprietary, and thus CAS numbers and other limited information may not be available for release.

In no event shall TI's liability arising out of such information exceed the total purchase price of the TI part(s) at issue in this document sold by TI to Customer on an annual basis.

## IMPORTANT NOTICE

Texas Instruments Incorporated and its subsidiaries (TI) reserve the right to make corrections, modifications, enhancements, improvements, and other changes to its products and services at any time and to discontinue any product or service without notice. Customers should obtain the latest relevant information before placing orders and should verify that such information is current and complete. All products are sold subject to TI's terms and conditions of sale supplied at the time of order acknowledgment.

TI warrants performance of its hardware products to the specifications applicable at the time of sale in accordance with TI's standard warranty. Testing and other quality control techniques are used to the extent TI deems necessary to support this warranty. Except where mandated by government requirements, testing of all parameters of each product is not necessarily performed.

TI assumes no liability for applications assistance or customer product design. Customers are responsible for their products and applications using TI components. To minimize the risks associated with customer products and applications, customers should provide adequate design and operating safeguards.

TI does not warrant or represent that any license, either express or implied, is granted under any TI patent right, copyright, mask work right, or other TI intellectual property right relating to any combination, machine, or process in which TI products or services are used. Information published by TI regarding third-party products or services does not constitute a license from TI to use such products or services or a warranty or endorsement thereof. Use of such information may require a license from a third party under the patents or other intellectual property of the third party, or a license from TI under the patents or other intellectual property of TI.

Reproduction of information in TI data books or data sheets is permissible only if reproduction is without alteration and is accompanied by all associated warranties, conditions, limitations, and notices. Reproduction of this information with alteration is an unfair and deceptive business practice. TI is not responsible or liable for such altered documentation.

Resale of TI products or services with statements different from or beyond the parameters stated by TI for that product or service voids all express and any implied warranties for the associated TI product or service and is an unfair and deceptive business practice. TI is not responsible or liable for any such statements.

Following are URLs where you can obtain information on other Texas Instruments products and application solutions:

<b>Products</b>		<b>Applications</b>	
Amplifiers	<a href="http://amplifier.ti.com">amplifier.ti.com</a>	Audio	<a href="http://www.ti.com/audio">www.ti.com/audio</a>
Data Converters	<a href="http://dataconverter.ti.com">dataconverter.ti.com</a>	Automotive	<a href="http://www.ti.com/automotive">www.ti.com/automotive</a>
DSP	<a href="http://dsp.ti.com">dsp.ti.com</a>	Broadband	<a href="http://www.ti.com/broadband">www.ti.com/broadband</a>
Interface	<a href="http://interface.ti.com">interface.ti.com</a>	Digital Control	<a href="http://www.ti.com/digitalcontrol">www.ti.com/digitalcontrol</a>
Logic	<a href="http://logic.ti.com">logic.ti.com</a>	Military	<a href="http://www.ti.com/military">www.ti.com/military</a>
Power Mgmt	<a href="http://power.ti.com">power.ti.com</a>	Optical Networking	<a href="http://www.ti.com/opticalnetwork">www.ti.com/opticalnetwork</a>
Microcontrollers	<a href="http://microcontroller.ti.com">microcontroller.ti.com</a>	Security	<a href="http://www.ti.com/security">www.ti.com/security</a>
Low Power Wireless	<a href="http://www.ti.com/lpw">www.ti.com/lpw</a>	Telephony	<a href="http://www.ti.com/telephony">www.ti.com/telephony</a>
		Video & Imaging	<a href="http://www.ti.com/video">www.ti.com/video</a>
		Wireless	<a href="http://www.ti.com/wireless">www.ti.com/wireless</a>

Mailing Address: Texas Instruments  
Post Office Box 655303 Dallas, Texas 75265