

INA125

# INSTRUMENTATION AMPLIFIER With Precision Voltage Reference

## FEATURES

- LOW QUIESCENT CURRENT: 460µA
- PRECISION VOLTAGE REFERENCE: 1.24V, 2.5V, 5V or 10V
- SLEEP MODE
- LOW OFFSET VOLTAGE: 250µV max
- LOW OFFSET DRIFT: 2µV/°C max
- LOW INPUT BIAS CURRENT: 20nA max
- HIGH CMR: 100dB min
- LOW NOISE: 38nV/√Hz at f = 1kHz
- INPUT PROTECTION TO ±40V
- WIDE SUPPLY RANGE  
Single Supply: 2.7V to 36V  
Dual Supply: ±1.35V to ±18V
- 16-PIN DIP AND SO-16 SOIC PACKAGES

## DESCRIPTION

The INA125 is a low power, high accuracy instrumentation amplifier with a precision voltage reference. It provides complete bridge excitation and precision differential-input amplification on a single integrated circuit.

A single external resistor sets any gain from 4 to 10,000. The INA125 is laser-trimmed for low offset voltage (250µV), low offset drift (2µV/°C), and high common-mode rejection (100dB at G = 100). It operates on single (+2.7V to +36V) or dual (±1.35V to ±18V) supplies.

The voltage reference is externally adjustable with pin-selectable voltages of 2.5V, 5V, or 10V, allowing use with a variety of transducers. The reference voltage is accurate to ±0.5% (max) with ±35ppm/°C drift (max). Sleep mode allows shutdown and duty cycle operation to save power.

The INA125 is available in 16-pin plastic DIP and SO-16 surface-mount packages and is specified for the -40°C to +85°C industrial temperature range.

## APPLICATIONS

- PRESSURE AND TEMPERATURE BRIDGE AMPLIFIERS
- INDUSTRIAL PROCESS CONTROL
- FACTORY AUTOMATION
- MULTI-CHANNEL DATA ACQUISITION
- BATTERY OPERATED SYSTEMS
- GENERAL PURPOSE INSTRUMENTATION

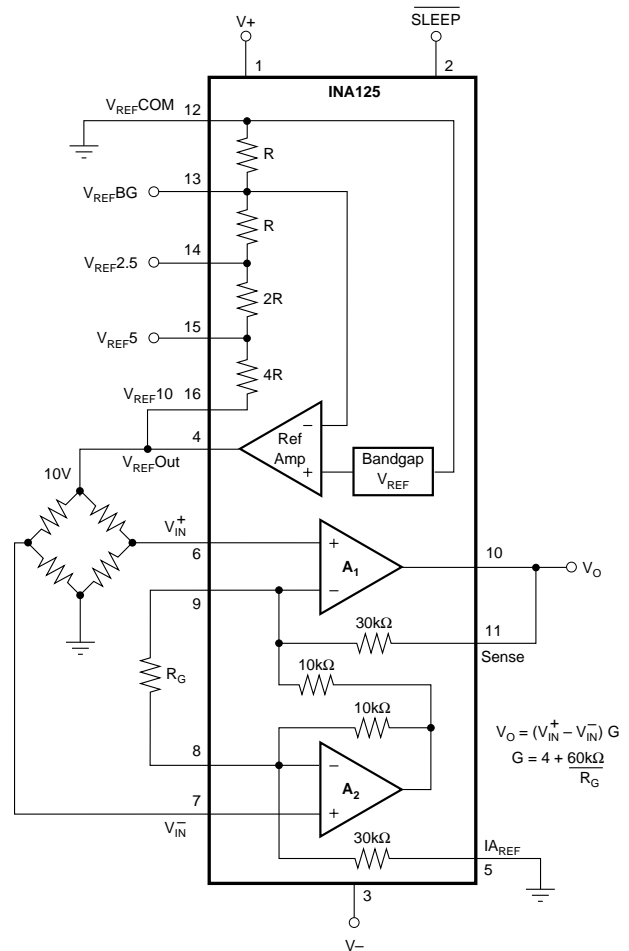

# SPECIFICATIONS: $V_S = \pm 15V$

At  $T_A = +25^\circ C$ ,  $V_S = \pm 15V$ ,  $I_A$  common =  $0V$ ,  $V_{REF}$  common =  $0V$ , and  $R_L = 10k\Omega$ , unless otherwise noted.

PARAMETER	CONDITIONS	INA125P, U			INA125PA, UA			UNITS	
		MIN	TYP	MAX	MIN	TYP	MAX		
<b>INPUT</b>									
Offset Voltage, RTI	$V_S = \pm 1.35V$ to $\pm 18V$ , $G = 4$		$\pm 50$	$\pm 250$		*	$\pm 500$	$\mu V$	
Initial vs Temperature			$\pm 0.25$	$\pm 2$		*	$\pm 5$	$\mu V/^\circ C$	
vs Power Supply			$\pm 3$	$\pm 20$		*	$\pm 50$	$\mu V/V$	
Long-Term Stability				$\pm 0.2$		*		$\mu V/mo$	
Impedance, Differential				$10^{11} \parallel 2$		*		$\Omega \parallel pF$	
Common-Mode			$10^{11} \parallel 9$		*		$\Omega \parallel pF$		
Safe Input Voltage				$\pm 40$			*	V	
Input Voltage Range	$V_{CM} = -10.7V$ to $+10.2V$		See Text			*			
Common-Mode Rejection		$G = 4$	78	84	72	*		dB	
		$G = 10$	86	94	80	*		dB	
		$G = 100$	100	114	90	*		dB	
		$G = 500$	100	114	90	*		dB	
<b>BIAS CURRENT</b>	$V_{CM} = 0V$		10	25		*	50	nA	
vs Temperature			$\pm 60$			*		$pA/^\circ C$	
Offset Current			$\pm 0.5$	$\pm 2.5$		*	$\pm 5$	nA	
vs Temperature			$\pm 0.5$			*		$pA/^\circ C$	
<b>NOISE, RTI</b>	$R_S = 0\Omega$					*		$nV/\sqrt{Hz}$	
Voltage Noise, $f = 10Hz$			40			*		$nV/\sqrt{Hz}$	
$f = 100Hz$			38			*		$nV/\sqrt{Hz}$	
$f = 1kHz$			38			*		$nV/\sqrt{Hz}$	
$f = 0.1Hz$ to $10Hz$			0.8			*		$\mu Vp-p$	
Current Noise, $f = 10Hz$			170			*		$fA/\sqrt{Hz}$	
$f = 1kHz$			56			*		$fA/\sqrt{Hz}$	
$f = 0.1Hz$ to $10Hz$			5			*		$pAp-p$	
<b>GAIN</b>						*		V/V	
Gain Equation	$V_O = -14V$ to $+13.3V$	4	$4 + 60k\Omega/R_G$	10,000	*	*	*	V/V	
Range of Gain		$G = 4$		$\pm 0.01$	$\pm 0.075$		*	$\pm 0.1$	%
Gain Error		$G = 10$		$\pm 0.03$	$\pm 0.3$		*	$\pm 0.5$	%
		$G = 100$		$\pm 0.05$	$\pm 0.5$		*	$\pm 1$	%
		$G = 500$		$\pm 0.1$			*		%
Gain vs Temperature	$G = 4$		$\pm 1$	$\pm 15$		*	*	$ppm/^\circ C$	
	$G > 4^{(1)}$		$\pm 25$	$\pm 100$		*	*	$ppm/^\circ C$	
Nonlinearity	$V_O = -14V$ to $+13.3V$		$\pm 0.0004$	$\pm 0.002$		*	$\pm 0.004$	% of FS	
		$G = 10$		$\pm 0.0004$	$\pm 0.002$		*	$\pm 0.004$	% of FS
		$G = 100$		$\pm 0.001$	$\pm 0.01$		*	*	% of FS
		$G = 500$		$\pm 0.002$			*	*	% of FS
<b>OUTPUT</b>						*		V	
Voltage: Positive		$(V+) - 1.7$	$(V+) - 0.9$		*	*		V	
Negative		$(V-) + 1$	$(V-) + 0.4$		*	*		V	
Load Capacitance Stability			1000			*		pF	
Short-Circuit Current			$-9/+12$			*		mA	
<b>VOLTAGE REFERENCE</b>	$V_{REF} = +2.5V, +5V, +10V$					*		%	
Accuracy	$I_L = 0$		$\pm 0.15$	$\pm 0.5$		*	$\pm 1$	%	
vs Temperature	$I_L = 0$		$\pm 18$	$\pm 35$		*	$\pm 100$	$ppm/^\circ C$	
vs Power Supply, $V+$	$V+ = (V_{REF} + 1.25V)$ to $+36V$		$\pm 20$	$\pm 50$		*	$\pm 100$	$ppm/V$	
vs Load	$I_L = 0$ to $5mA$		3	75		*	*	$ppm/mA$	
Dropout Voltage, $(V+) - V_{REF}^{(2)}$	Ref Load = $2k\Omega$	1.25	1		*	*		V	
Bandgap Voltage Reference			1.24			*		V	
Accuracy	$I_L = 0$		$\pm 0.5$			*		%	
vs Temperature	$I_L = 0$		$\pm 18$			*		$ppm/^\circ C$	

The information provided herein is believed to be reliable; however, BURR-BROWN assumes no responsibility for inaccuracies or omissions. BURR-BROWN assumes no responsibility for the use of this information, and all use of such information shall be entirely at the user's own risk. Prices and specifications are subject to change without notice. No patent rights or licenses to any of the circuits described herein are implied or granted to any third party. BURR-BROWN does not authorize or warrant any BURR-BROWN product for use in life support devices and/or systems.

## SPECIFICATIONS: $V_S = \pm 15V$ (CONT)

At  $T_A = +25^\circ C$ ,  $V_S = \pm 15V$ ,  $I_A$  common = 0V,  $V_{REF}$  common = 0V, and  $R_L = 10k\Omega$ , unless otherwise noted.

PARAMETER CONDITIONS		INA125P, U			INA125PA, UA			UNITS
		MIN	TYP	MAX	MIN	TYP	MAX	
<b>FREQUENCY RESPONSE</b> Bandwidth, -3dB	G = 4		150			*		kHz
	G = 10		45			*		kHz
	G = 100		4.5			*		kHz
	G = 500		0.9			*		kHz
Slew Rate	G = 4, 10V Step		0.2			*		V/ $\mu s$
Settling Time, 0.01%	G = 4, 10V Step		60			*		$\mu s$
	G = 10, 10V Step		83			*		$\mu s$
	G = 100, 10V Step		375			*		$\mu s$
Overload Recovery	G = 500, 10V Step		1700			*		$\mu s$
	50% Overdrive		5			*		$\mu s$
<b>POWER SUPPLY</b> Specified Operating Voltage			$\pm 15$			*		V
Specified Voltage Range		$\pm 1.35$		$\pm 18$	*		*	V
Quiescent Current, Positive	$I_O = I_{REF} = 0mA$		460	525		*	*	$\mu A$
	$I_O = I_{REF} = 0mA$		-280	-325		*	*	$\mu A$
Reference Ground Current <sup>(3)</sup>			180			*	*	$\mu A$
Sleep Current ( $V_{SLEEP} \leq 100mV$ )	$R_L = 10k\Omega$ , Ref Load = 2k $\Omega$		$\pm 1$	$\pm 25$		*	*	$\mu A$
<b>SLEEP MODE PIN<sup>(4)</sup></b> $V_{IH}$ (Logic high input voltage)		+2.7		V+	*		*	V
$V_{IL}$ (Logic low input voltage)		0		+0.1	*		*	V
$I_{IH}$ (Logic high input current)			15			*		$\mu A$
$I_{IL}$ (Logic low input current)			0			*		$\mu A$
Wake-up Time <sup>(5)</sup>			150			*		$\mu s$
<b>TEMPERATURE RANGE</b> Specification Range		-40		+85	*		*	$^\circ C$
Operation Range		-55		+125	*		*	$^\circ C$
Storage Range		-55		+125	*		*	$^\circ C$
Thermal Resistance, $\theta_{JA}$								
16-Pin DIP			80			*		$^\circ C/W$
SO-16 Surface-Mount			100			*		$^\circ C/W$

\* Specification same as INA125P, U.

NOTES: (1) Temperature coefficient of the "Internal Resistor" in the gain equation. Does not include TCR of gain-setting resistor,  $R_G$ . (2) Dropout voltage is the positive supply voltage minus the reference voltage that produces a 1% decrease in reference voltage. (3)  $V_{REFCOM}$  pin. (4) Voltage measured with respect to Reference Common. Logic low input selects Sleep mode. (5)  $I_A$  and Reference, see Typical Performance Curves.

## SPECIFICATIONS: $V_S = +5V$

At  $T_A = +25^\circ C$ ,  $V_S = +5V$ ,  $I_A$  common at  $V_S/2$ ,  $V_{REF}$  common =  $V_S/2$ ,  $V_{CM} = V_S/2$ , and  $R_L = 10k\Omega$  to  $V_S/2$ , unless otherwise noted.

PARAMETER	CONDITIONS	INA125P, U			INA125PA, UA			UNITS
		MIN	TYP	MAX	MIN	TYP	MAX	
<b>INPUT</b> Offset Voltage, RTI Initial	$V_S = +2.7V$ to $+36V$		$\pm 75$	$\pm 500$		*	$\pm 750$	$\mu V$
vs Temperature			$\pm 0.25$			*		$\mu V/^\circ C$
vs Power Supply			3	20		*	50	$\mu V/V$
Input Voltage Range	$V_{CM} = +1.1V$ to $+3.6V$		See Text			*		
Common-Mode Rejection		G = 4	78	84	72	*		dB
		G = 10	86	94	80	*		dB
		G = 100	100	114	90	*		dB
		G = 500	100	114	90	*		dB
<b>GAIN</b> Gain Error	$V_O = +0.3V$ to $+3.8V$ G = 4		$\pm 0.01$			*		%
<b>OUTPUT</b> Voltage, Positive		(V+)-1.2	(V+)-0.8		*	*		V
Negative		(V-)+0.3	(V-)+0.15		*	*		V
<b>POWER SUPPLY</b> Specified Operating Voltage			+5			*		V
Operating Voltage Range		+2.7		+36	*		*	V
Quiescent Current	$I_O = I_{REF} = 0mA$		460	525		*	*	$\mu A$
Sleep Current ( $V_{SLEEP} \leq 100mV$ )	$R_L = 10k\Omega$ , Ref Load = 2k $\Omega$		$\pm 1$	$\pm 25$		*	*	$\mu A$

\* Specification same as INA125P, U.

## PIN CONFIGURATION

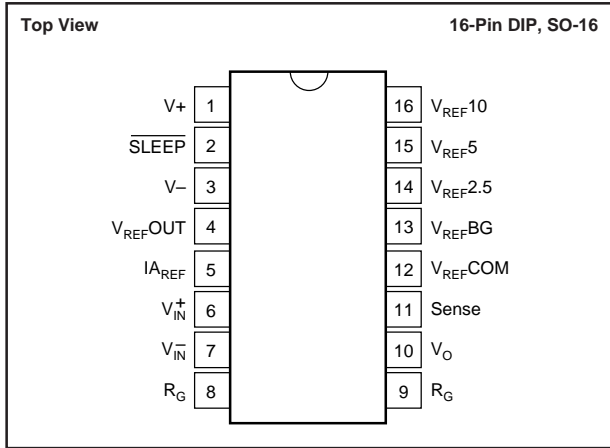

## ABSOLUTE MAXIMUM RATINGS<sup>(1)</sup>

Power Supply Voltage, V+ to V-	36V
Input Signal Voltage	±40V
Output Short Circuit	Continuous
Operating Temperature	-55°C to +125°C
Storage Temperature	-55°C to +125°C
Lead Temperature (soldering, 10s)	+300°C

NOTE: Stresses above these ratings may cause permanent damage.

## PACKAGE INFORMATION

PRODUCT	PACKAGE	PACKAGE DRAWING NUMBER <sup>(1)</sup>
INA125PA	16-Pin Plastic DIP	180
INA125P	16-Pin Plastic DIP	180
INA125UA	SO-16 Surface-Mount	265
INA125U	SO-16 Surface-Mount	265

NOTES: (1) For detailed drawing and dimension table, please see end of data sheet, or Appendix C of Burr-Brown IC Data Book.

## ELECTROSTATIC DISCHARGE SENSITIVITY

This integrated circuit can be damaged by ESD. Burr-Brown recommends that all integrated circuits be handled with appropriate precautions. Failure to observe proper handling and installation procedures can cause damage.

ESD damage can range from subtle performance degradation to complete device failure. Precision integrated circuits may be more susceptible to damage because very small parametric changes could cause the device not to meet its published specifications.

# TYPICAL PERFORMANCE CURVES

At  $T_A = +25^\circ\text{C}$  and  $V_S = \pm 15\text{V}$ , unless otherwise noted.

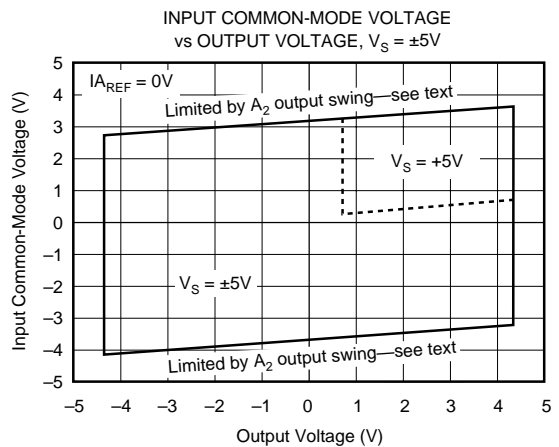
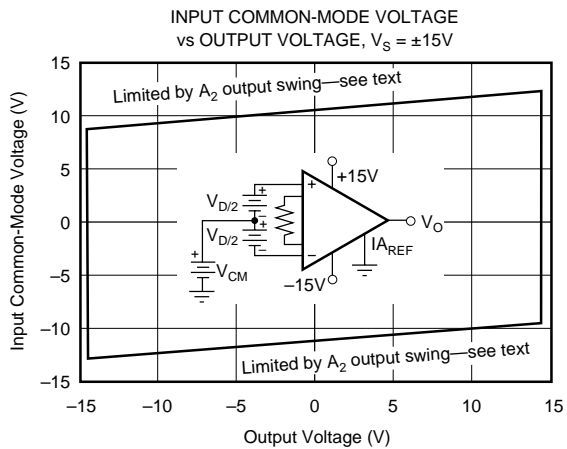
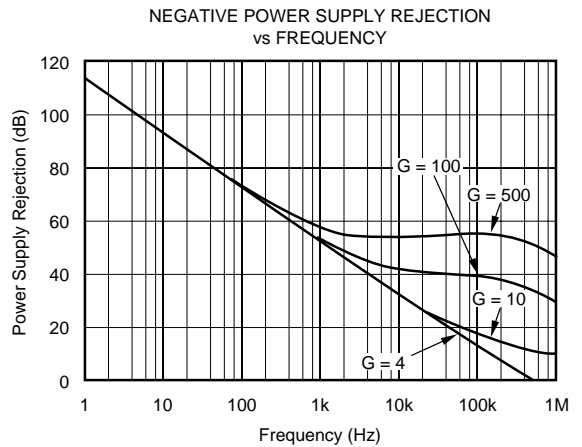
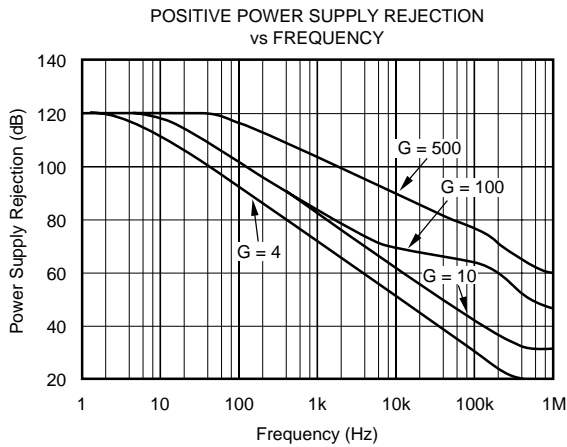
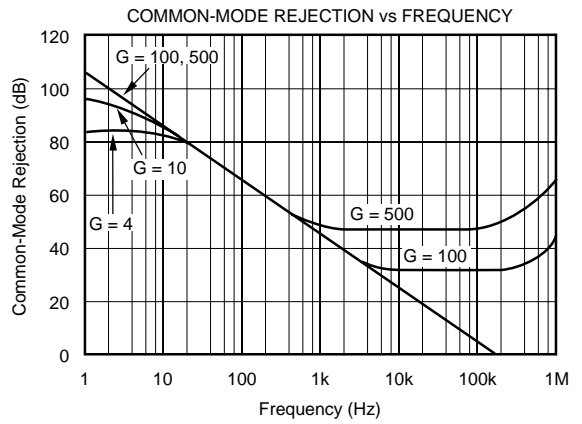
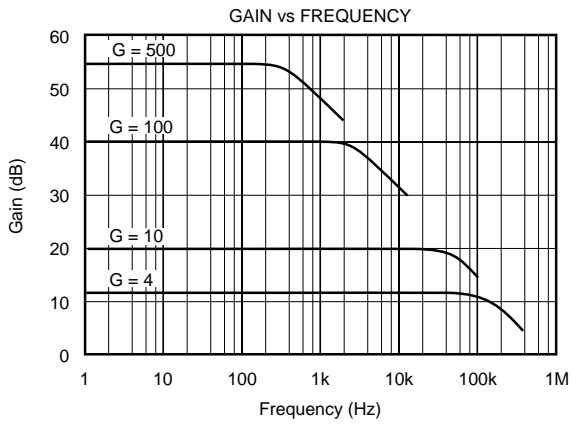

# TYPICAL PERFORMANCE CURVES (CONT)

At  $T_A = +25^\circ\text{C}$  and  $V_S = \pm 15\text{V}$ , unless otherwise noted.

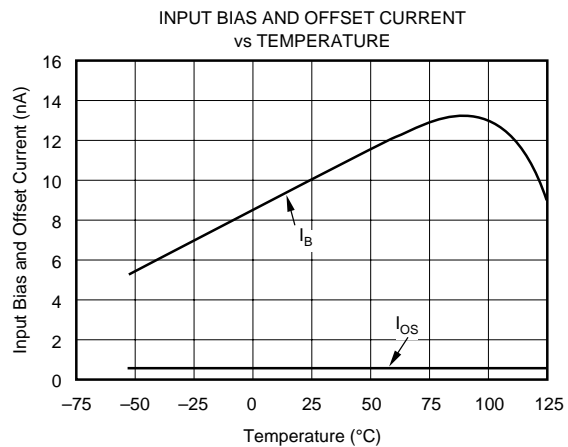
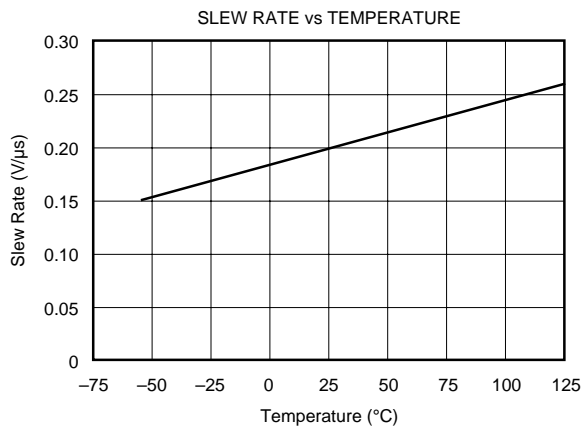
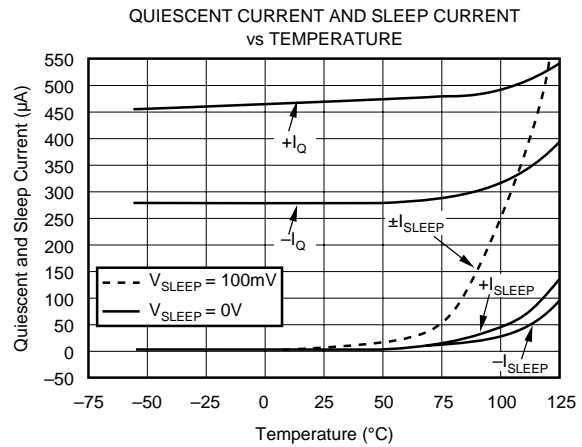
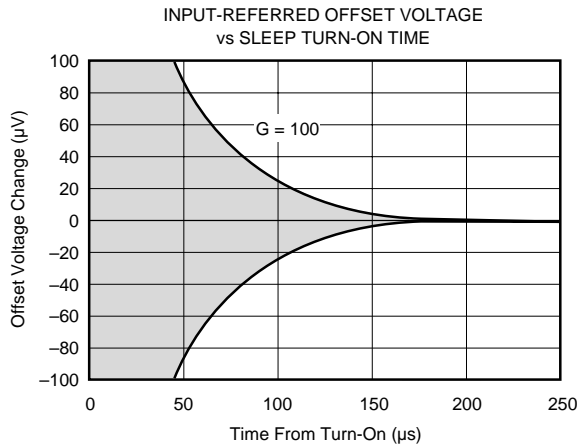
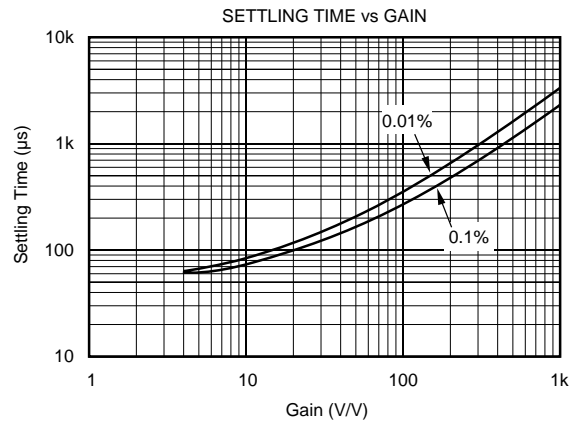
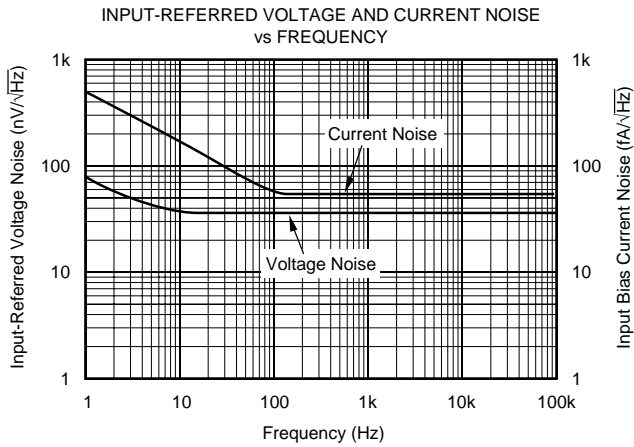

# TYPICAL PERFORMANCE CURVES (CONT)

At  $T_A = +25^\circ\text{C}$  and  $V_S = \pm 15\text{V}$ , unless otherwise noted.

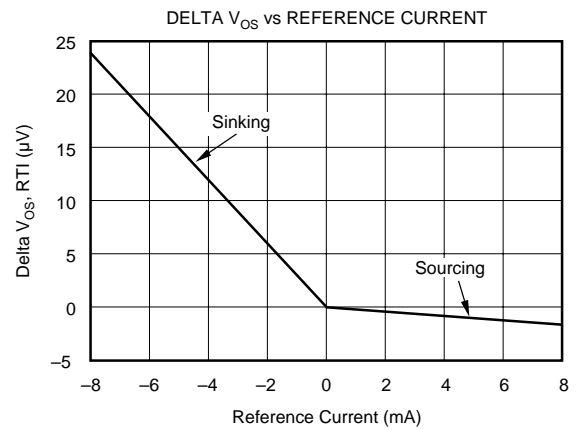
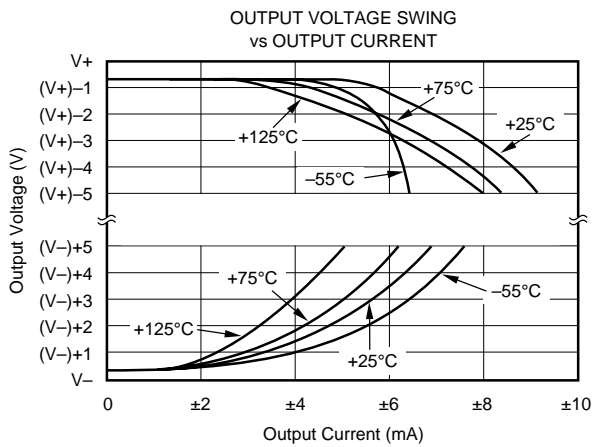
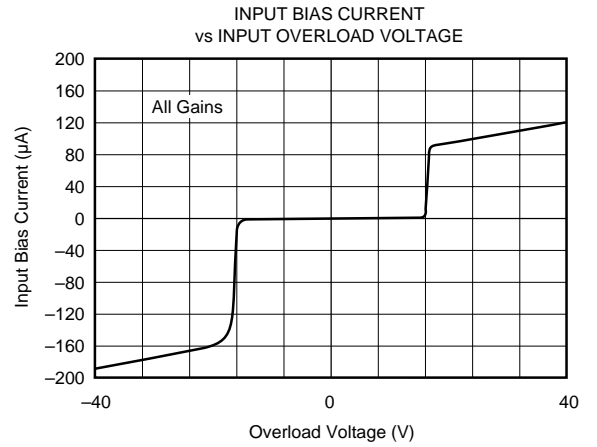
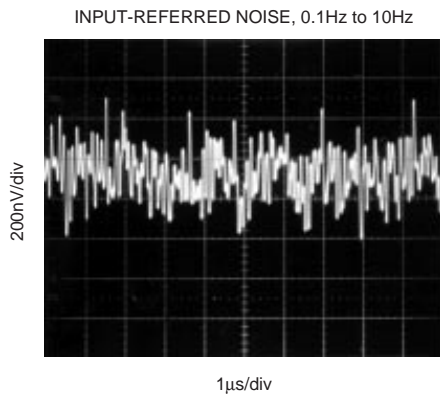
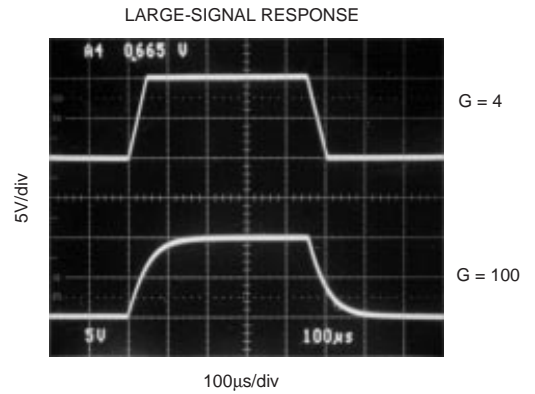
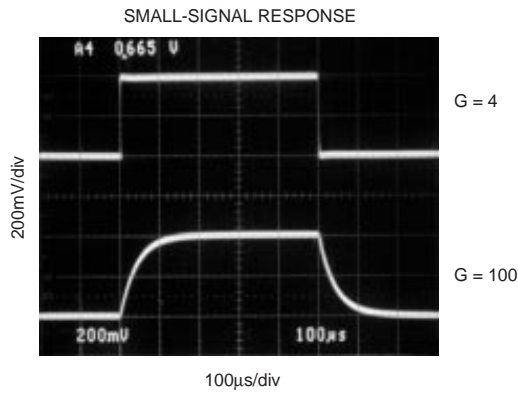

# TYPICAL PERFORMANCE CURVES (CONT)

At  $T_A = +25^\circ\text{C}$  and  $V_S = \pm 15\text{V}$ , unless otherwise noted.

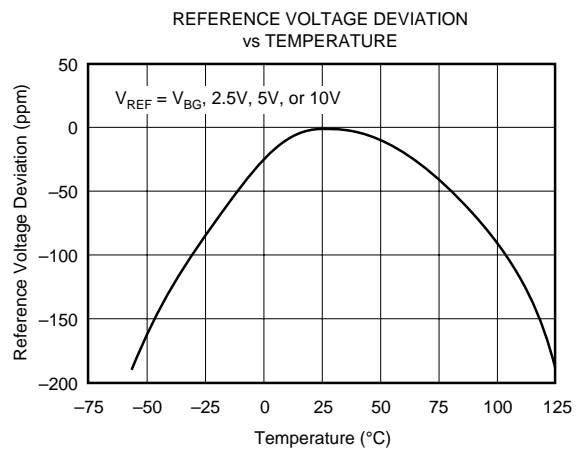
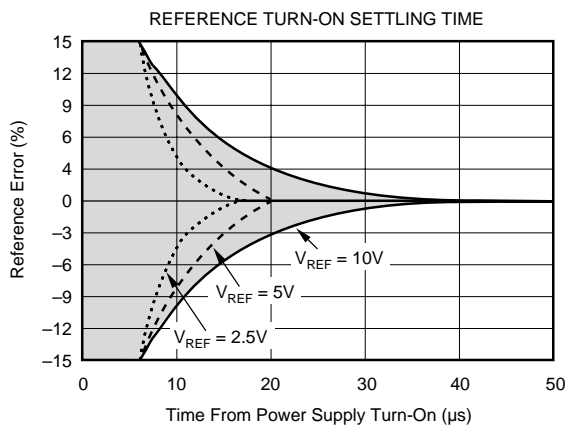
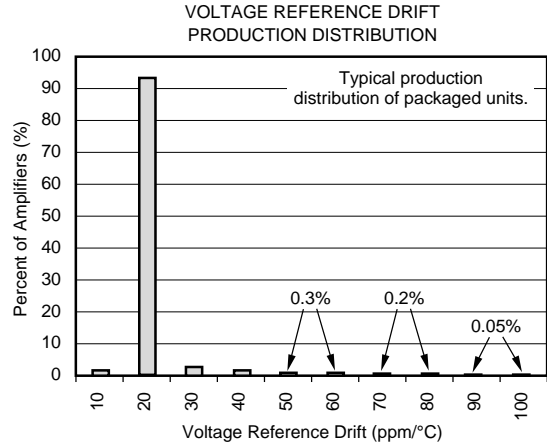
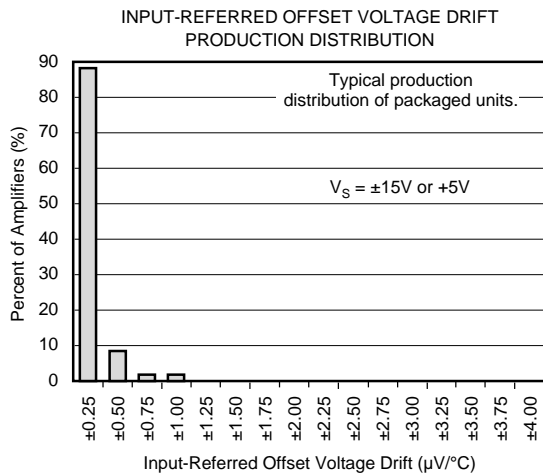
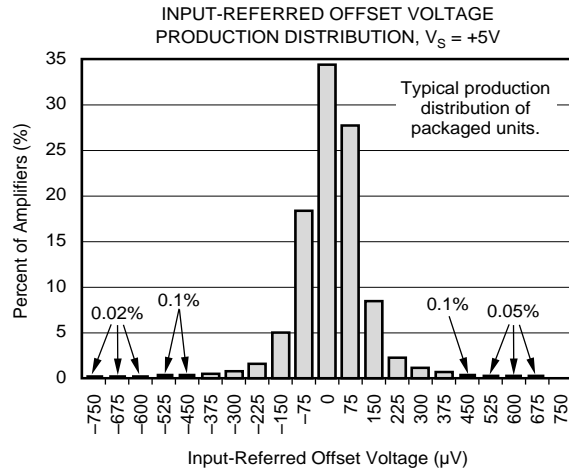
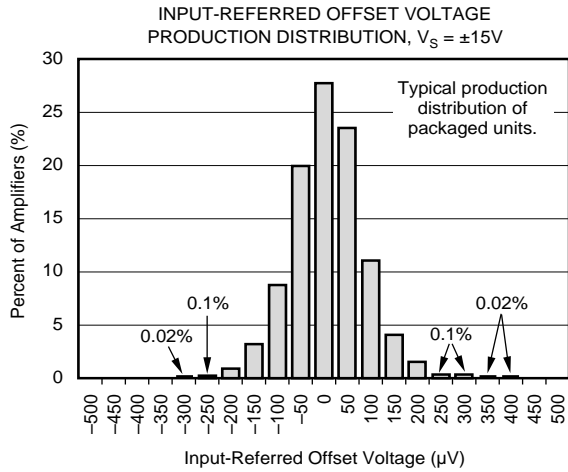

# TYPICAL PERFORMANCE CURVES (CONT)

At  $T_A = +25^\circ\text{C}$  and  $V_S = \pm 15\text{V}$ , unless otherwise noted.

0.1Hz to 10Hz REFERENCE NOISE  
 $V_{REF} = 2.5\text{V}$ ,  $C_L = 100\text{pF}$

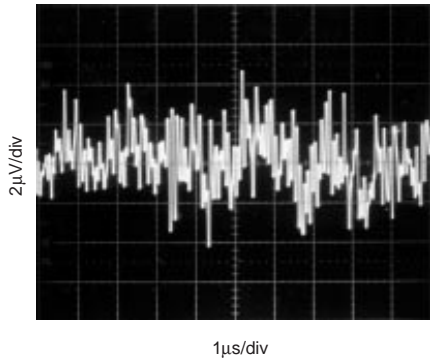

REFERENCE TRANSIENT RESPONSE  
 $V_{REF} = 2.5\text{V}$ ,  $C_L = 100\text{pF}$

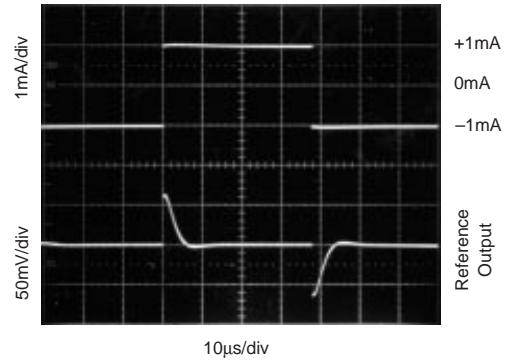

POSITIVE REFERENCE AC LINE REJECTION  
 vs FREQUENCY

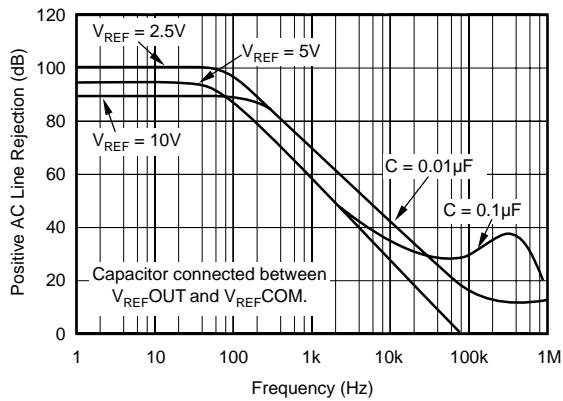

NEGATIVE REFERENCE AC LINE REJECTION  
 vs FREQUENCY

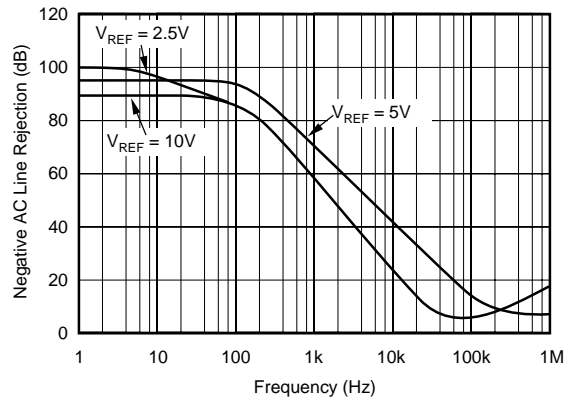

# APPLICATION INFORMATION

Figure 1 shows the basic connections required for operation of the INA125. Applications with noisy or high impedance power supplies may require decoupling capacitors close to the device pins as shown.

The output is referred to the instrumentation amplifier reference ( $I_{A\_REF}$ ) terminal which is normally grounded. This must be a low impedance connection to assure good common-mode rejection. A resistance of  $12\Omega$  in series with the  $I_{A\_REF}$  pin will cause a typical device to degrade to approximately 80dB CMR ( $G = 4$ ).

Connecting  $V_{REF\_OUT}$  (pin 4) to one of the four available reference voltage pins ( $V_{REF\_BG}$ ,  $V_{REF\_2.5}$ ,  $V_{REF\_5}$ , or  $V_{REF\_10}$ ) provides an accurate voltage source for bridge applications.

For example, in Figure 1  $V_{REF\_OUT}$  is connected to  $V_{REF\_10}$  thus supplying 10V to the bridge. It is recommended that  $V_{REF\_OUT}$  be connected to one of the reference voltage pins even when the reference is not being utilized to avoid saturating the reference amplifier. Driving the  $SLEEP$  pin LOW puts the INA125 in a shutdown mode.

## SETTING THE GAIN

Gain of the INA125 is set by connecting a single external resistor,  $R_G$ , between pins 8 and 9:

$$G = 4 + \frac{60k\Omega}{R_G} \quad (1)$$

Commonly used gains and  $R_G$  resistor values are shown in Figure 1.

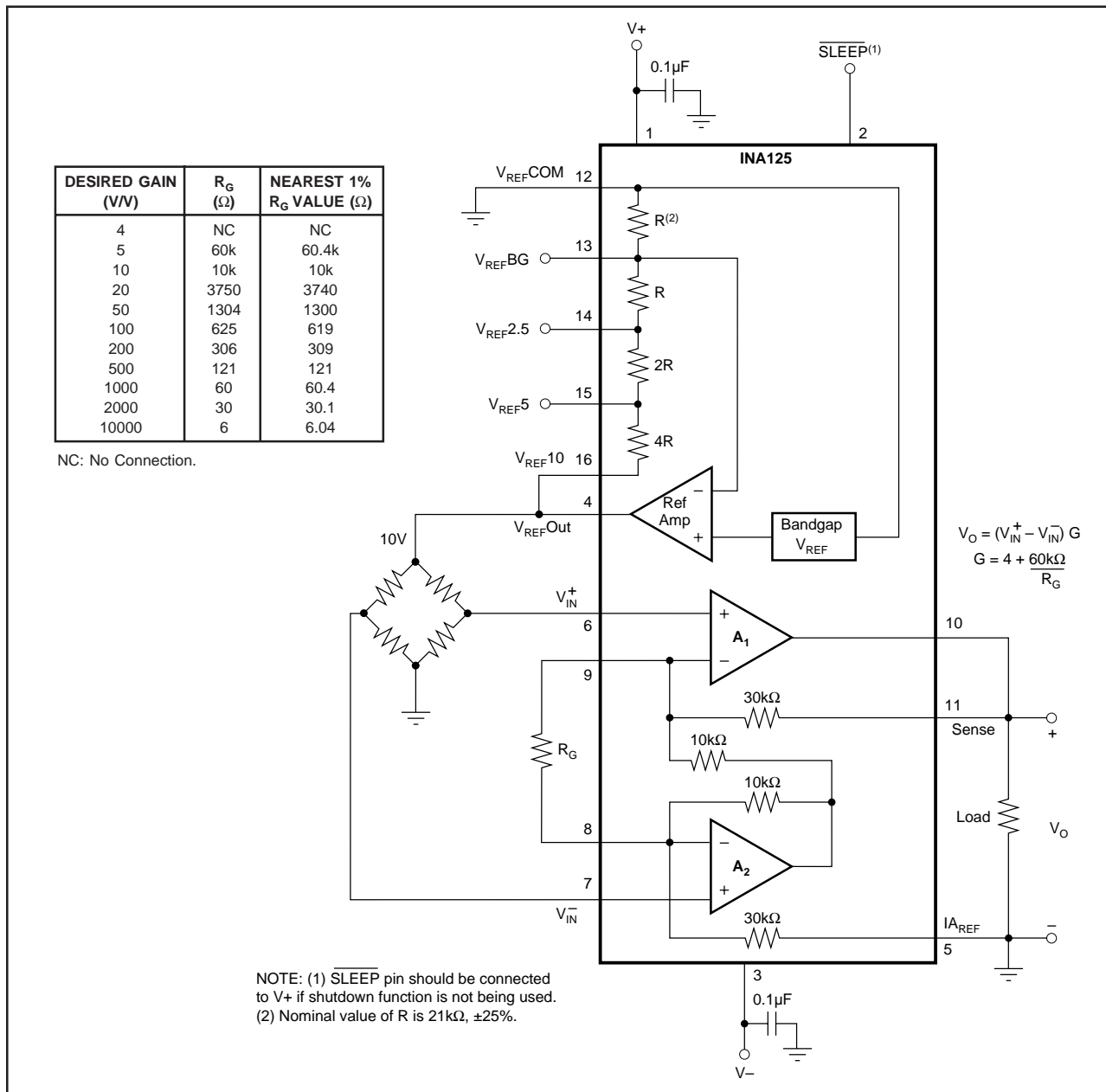

FIGURE 1. Basic Connections.

The 60kΩ term in equation 1 comes from the internal metal film resistors which are laser trimmed to accurate absolute values. The accuracy and temperature coefficient of these resistors are included in the gain accuracy and drift specifications of the INA125.

The stability and temperature drift of the external gain setting resistor,  $R_G$ , also affects gain.  $R_G$ 's contribution to gain accuracy and drift can be directly inferred from the gain equation (1). Low resistor values required for high gain can make wiring resistance important. Sockets add to the wiring resistance, which will contribute additional gain error (possibly an unstable gain error) in gains of approximately 100 or greater.

### OFFSET TRIMMING

The INA125 is laser trimmed for low offset voltage and offset voltage drift. Most applications require no external offset adjustment. Figure 2 shows an optional circuit for trimming the output offset voltage. The voltage applied to the  $I_{A\_REF}$  terminal is added to the output signal. The op amp buffer is used to provide low impedance at the  $I_{A\_REF}$  terminal to preserve good common-mode rejection.

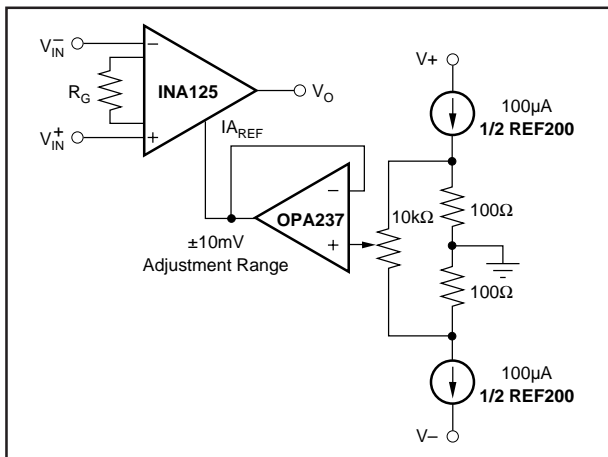

FIGURE 2. Optional Trimming of Output Offset Voltage.

### INPUT BIAS CURRENT RETURN

The input impedance of the INA125 is extremely high—approximately  $10^{11}\Omega$ . However, a path must be provided for the input bias current of both inputs. This input bias current flows out of the device and is approximately 10nA. High input impedance means that this input bias current changes very little with varying input voltage.

Input circuitry must provide a path for this input bias current for proper operation. Figure 3 shows various provisions for an input bias current path. Without a bias current path, the inputs will float to a potential which exceeds the common-mode range, and the input amplifiers will saturate.

If the differential source resistance is low, the bias current return path can be connected to one input (see the thermocouple example in Figure 3). With higher source impedance, using two equal resistors provides a balanced input with possible advantages of lower input offset voltage due to bias current and better high frequency common-mode rejection.

### INPUT COMMON-MODE RANGE

The input common-mode range of the INA125 is shown in the typical performance curves. The common-mode range is limited on the negative side by the output voltage swing of  $A_2$ , an internal circuit node that cannot be measured on an external pin. The output voltage of  $A_2$  can be expressed as:

$$V_{O2} = 1.3V_{IN}^- - (V_{IN}^+ - V_{IN}^-) (10k\Omega/R_G)$$

(voltages referred to  $I_{A\_REF}$  terminal, pin 5)

The internal op amp  $A_2$  is identical to  $A_1$ . Its output swing is limited to approximately 0.8V from the positive supply and 0.25V from the negative supply. When the input common-mode range is exceeded ( $A_2$ 's output is saturated),  $A_1$  can still be in linear operation, responding to changes in the non-inverting input voltage. The output voltage, however, will be invalid.

### PRECISION VOLTAGE REFERENCE

The on-board precision voltage reference provides an accurate voltage source for bridge and other transducer applications or ratiometric conversion with analog-to-digital converters. A reference output of 2.5V, 5V or 10V is available by connecting  $V_{REF\_OUT}$  (pin 4) to one of the  $V_{REF}$  pins ( $V_{REF2.5}$ ,  $V_{REF5}$ , or  $V_{REF10}$ ). Reference voltages are laser-trimmed for low initial error and low temperature drift. Connecting  $V_{REF\_OUT}$  to  $V_{REF\_BG}$  (pin 13) produces the bandgap reference voltage ( $1.24V \pm 0.5\%$ ) at the reference output.

Positive supply voltage must be 1.25V above the desired reference voltage. For example, with  $V_+ = 2.7V$ , only the 1.24V reference ( $V_{REF\_BG}$ ) can be used. If using dual supplies  $V_{REF\_COM}$  can be connected to  $V_-$ , increasing the

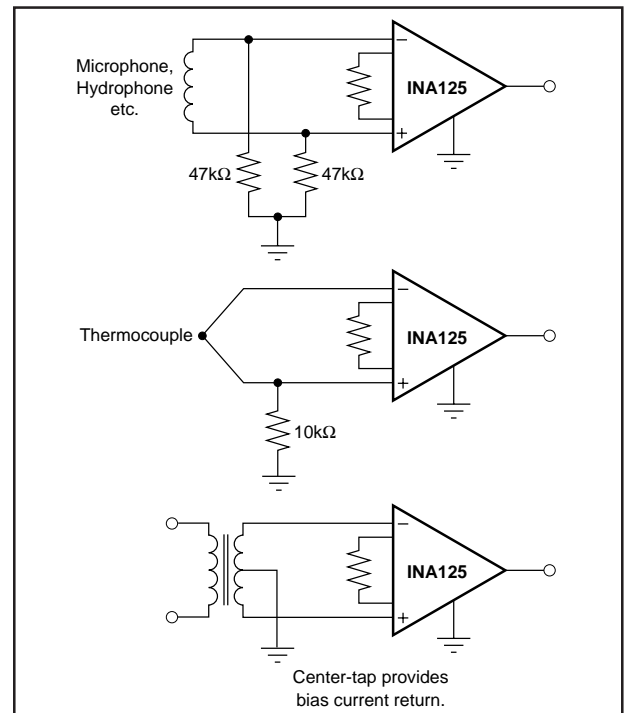

FIGURE 3. Providing an Input Common-Mode Current Path.

amount of supply voltage headroom available to the reference. Approximately  $180\mu\text{A}$  flows out of the  $V_{\text{REFCOM}}$  terminal, therefore, it is recommended that it be connected through a low impedance path to sensor common to avoid possible ground loop problems.

Reference noise is proportional to the reference voltage selected. With  $V_{\text{REF}} = 2.5\text{V}$ , 0.1Hz to 10Hz peak-to-peak noise is approximately  $9\mu\text{Vp-p}$ . Noise increases to  $36\mu\text{Vp-p}$  for the 10V reference. Output drive capability of the voltage reference is improved by connecting a transistor as shown in Figure 4. The external transistor also serves to remove power from the INA125.

Internal resistors that set the voltage reference output are ratio-trimmed for accurate output voltages ( $\pm 0.5\%$  max). The absolute resistance values, however, may vary  $\pm 25\%$ . Adjustment of the reference output voltage with an external resistor is not recommended because the required resistor value is uncertain.

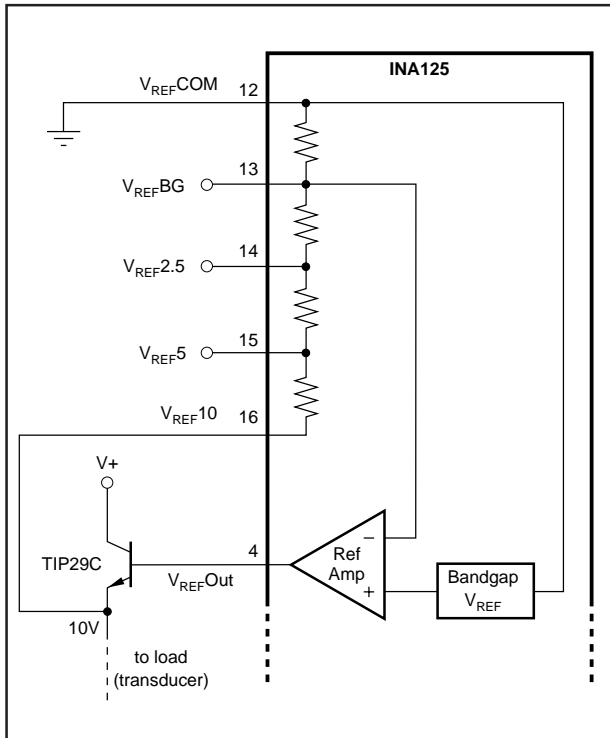

FIGURE 4. Reference Current Boost.

## SHUTDOWN

The INA125 has a shutdown option. When the  $\overline{\text{SLEEP}}$  pin is LOW (100mV or less), the supply current drops to approximately  $1\mu\text{A}$  and output impedance becomes approximately  $80\text{k}\Omega$ . Best performance is achieved with CMOS logic. To maintain low sleep current at high temperatures,  $V_{\text{SLEEP}}$  should be as close to 0V as possible. This should not be a problem if using CMOS logic unless the CMOS gate is driving other currents. Refer to the typical performance curve, “Sleep Current vs Temperature.”

A transition region exists when  $V_{\text{SLEEP}}$  is between 400mV and 2.7V (with respect to  $V_{\text{REFCOM}}$ ) where the output is unpredictable. Operation in this region is not recommended. The INA125 achieves high accuracy quickly following wake-up ( $V_{\text{SLEEP}} \geq 2.7\text{V}$ ). See the typical performance curve “Input-Referred Offset Voltage vs Sleep Turn-on Time.” If shutdown is not being used, connect the  $\overline{\text{SLEEP}}$  pin to  $V+$ .

## LOW VOLTAGE OPERATION

The INA125 can be operated on power supplies as low as  $\pm 1.35\text{V}$ . Performance remains excellent with power supplies ranging from  $\pm 1.35\text{V}$  to  $\pm 18\text{V}$ . Most parameters vary only slightly throughout this supply voltage range—see typical performance curves. Operation at very low supply voltage requires careful attention to ensure that the common-mode voltage remains within its linear range. See “Input Common-Mode Voltage Range.” As previously mentioned, when using the on-board reference with low supply voltages, it may be necessary to connect  $V_{\text{REFCOM}}$  to  $V-$  to ensure  $V_S - V_{\text{REF}} \geq 1.25\text{V}$ .

## SINGLE SUPPLY OPERATION

The INA125 can be used on single power supplies of +2.7V to +36V. Figure 5 shows a basic single supply circuit. The  $I_{\text{AREF}}$ ,  $V_{\text{REFCOM}}$ , and  $V-$  terminals are connected to ground. Zero differential input voltage will demand an output voltage of 0V (ground). When the load is referred to ground as shown, actual output voltage swing is limited to approximately 150mV above ground. The typical performance curve “Output Voltage Swing vs Output Current” shows how the output swing varies with output current.

With single supply operation, careful attention should be paid to input common-mode range, output voltage swing of both op amps, and the voltage applied to the  $I_{\text{AREF}}$  terminal.  $V_{\text{IN+}}$  and  $V_{\text{IN-}}$  must both be 1V above ground for linear operation. You cannot, for instance, connect the inverting input to ground and measure a voltage connected to the non-inverting input.

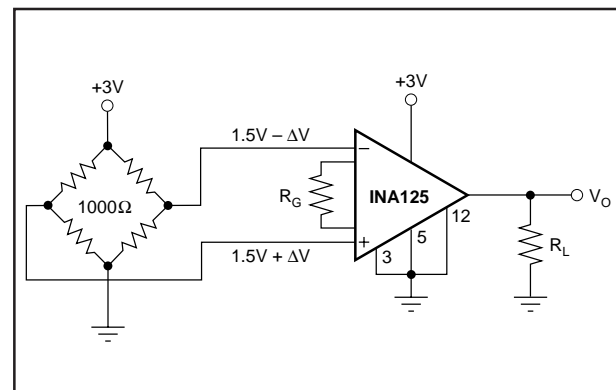

FIGURE 5. Single Supply Bridge Amplifier.

## INPUT PROTECTION

The inputs of the INA125 are individually protected for voltage up to  $\pm 40\text{V}$ . For example, a condition of  $-40\text{V}$  on one input and  $+40\text{V}$  on the other input will not cause damage. Internal circuitry on each input provides low series impedance under normal signal conditions. To provide equivalent protection, series input resistors would contribute

excessive noise. If the input is overloaded, the protection circuitry limits the input current to a safe value of approximately  $120\mu\text{A}$  to  $190\mu\text{A}$ . The typical performance curve "Input Bias Current vs Input Overload Voltage" shows this input current limit behavior. The inputs are protected even if the power supplies are disconnected or turned off.

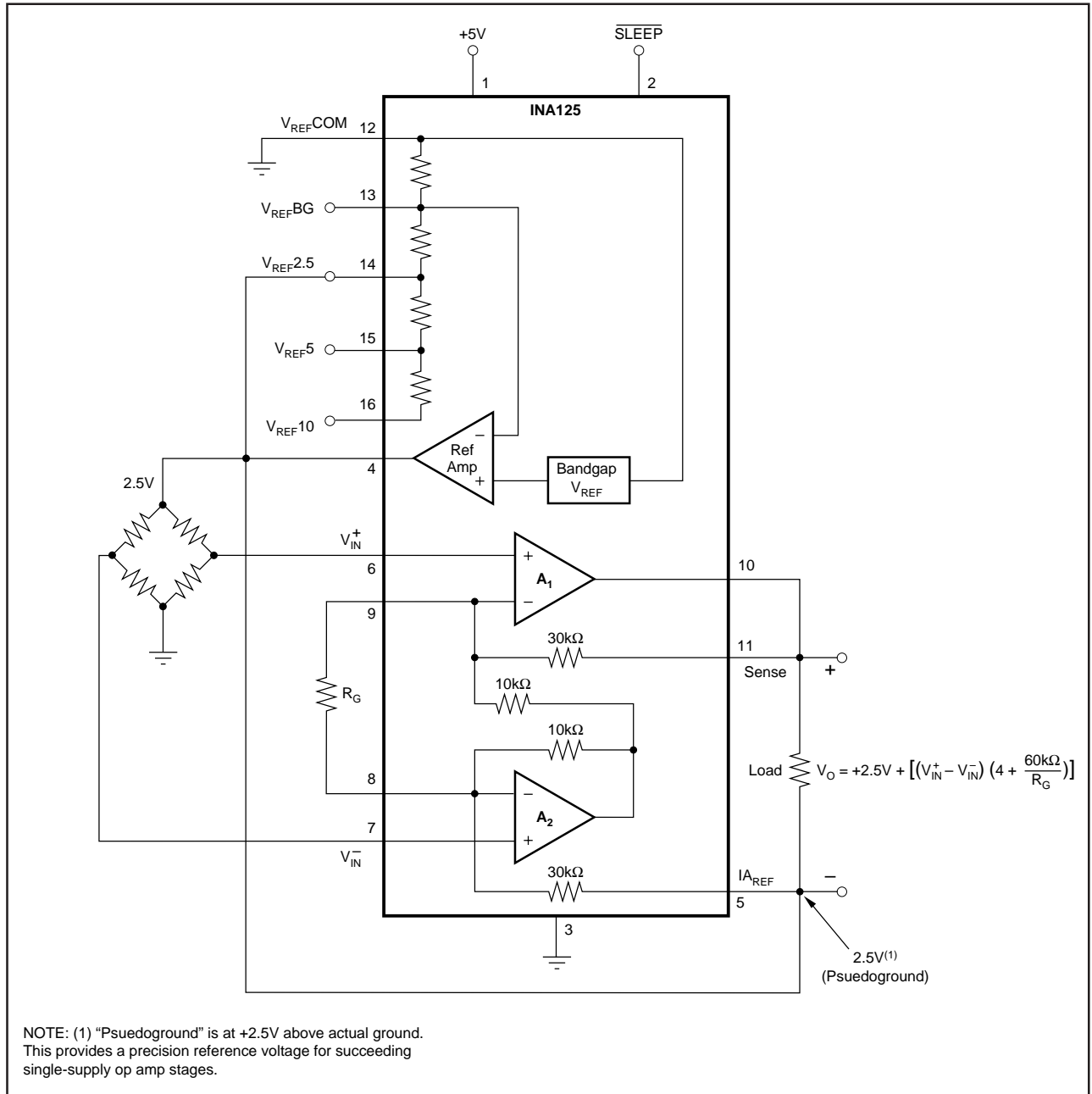

FIGURE 6. Psuedoground Bridge Measurement, 5V Single Supply.

**PACKAGING INFORMATION**

Orderable Device	Status <sup>(1)</sup>	Package Type	Package Drawing	Pins	Package Qty	Eco Plan <sup>(2)</sup>	Lead/Ball Finish	MSL Peak Temp <sup>(3)</sup>
INA125P	ACTIVE	PDIP	N	16	25	Green (RoHS & no Sb/Br)	CU NIPDAU	N / A for Pkg Type
INA125PA	ACTIVE	PDIP	N	16	25	Green (RoHS & no Sb/Br)	CU NIPDAU	N / A for Pkg Type
INA125PAG4	ACTIVE	PDIP	N	16	25	Green (RoHS & no Sb/Br)	CU NIPDAU	N / A for Pkg Type
INA125PG4	ACTIVE	PDIP	N	16	25	Green (RoHS & no Sb/Br)	CU NIPDAU	N / A for Pkg Type
INA125U	ACTIVE	SOIC	D	16	48	Pb-Free (RoHS)	CU NIPDAU	Level-3-260C-168 HR
INA125U/2K5	ACTIVE	SOIC	D	16	2500	Pb-Free (RoHS)	CU NIPDAU	Level-3-260C-168 HR
INA125U/2K5E4	ACTIVE	SOIC	D	16	2500	Pb-Free (RoHS)	CU NIPDAU	Level-3-260C-168 HR
INA125UA	ACTIVE	SOIC	D	16	48	Green (RoHS & no Sb/Br)	CU NIPDAU	Level-3-260C-168 HR
INA125UA/2K5	ACTIVE	SOIC	D	16	2500	Pb-Free (RoHS)	CU NIPDAU	Level-3-260C-168 HR
INA125UA/2K5E4	ACTIVE	SOIC	D	16	2500	Pb-Free (RoHS)	CU NIPDAU	Level-3-260C-168 HR
INA125UAG4	ACTIVE	SOIC	D	16	48	Green (RoHS & no Sb/Br)	CU NIPDAU	Level-3-260C-168 HR
INA125UE4	ACTIVE	SOIC	D	16	48	Pb-Free (RoHS)	CU NIPDAU	Level-3-260C-168 HR

<sup>(1)</sup> The marketing status values are defined as follows:

**ACTIVE:** Product device recommended for new designs.

**LIFEBUY:** TI has announced that the device will be discontinued, and a lifetime-buy period is in effect.

**NRND:** Not recommended for new designs. Device is in production to support existing customers, but TI does not recommend using this part in a new design.

**PREVIEW:** Device has been announced but is not in production. Samples may or may not be available.

**OBSOLETE:** TI has discontinued the production of the device.

<sup>(2)</sup> Eco Plan - The planned eco-friendly classification: Pb-Free (RoHS), Pb-Free (RoHS Exempt), or Green (RoHS & no Sb/Br) - please check <http://www.ti.com/productcontent> for the latest availability information and additional product content details.

**TBD:** The Pb-Free/Green conversion plan has not been defined.

**Pb-Free (RoHS):** TI's terms "Lead-Free" or "Pb-Free" mean semiconductor products that are compatible with the current RoHS requirements for all 6 substances, including the requirement that lead not exceed 0.1% by weight in homogeneous materials. Where designed to be soldered at high temperatures, TI Pb-Free products are suitable for use in specified lead-free processes.

**Pb-Free (RoHS Exempt):** This component has a RoHS exemption for either 1) lead-based flip-chip solder bumps used between the die and package, or 2) lead-based die adhesive used between the die and leadframe. The component is otherwise considered Pb-Free (RoHS compatible) as defined above.

**Green (RoHS & no Sb/Br):** TI defines "Green" to mean Pb-Free (RoHS compatible), and free of Bromine (Br) and Antimony (Sb) based flame retardants (Br or Sb do not exceed 0.1% by weight in homogeneous material)

<sup>(3)</sup> MSL, Peak Temp. -- The Moisture Sensitivity Level rating according to the JEDEC industry standard classifications, and peak solder temperature.

**Important Information and Disclaimer:** The information provided on this page represents TI's knowledge and belief as of the date that it is provided. TI bases its knowledge and belief on information provided by third parties, and makes no representation or warranty as to the accuracy of such information. Efforts are underway to better integrate information from third parties. TI has taken and continues to take reasonable steps to provide representative and accurate information but may not have conducted destructive testing or chemical analysis on incoming materials and chemicals. TI and TI suppliers consider certain information to be proprietary, and thus CAS numbers and other limited information may not be available for release.

In no event shall TI's liability arising out of such information exceed the total purchase price of the TI part(s) at issue in this document sold by TI to Customer on an annual basis.

## IMPORTANT NOTICE

Texas Instruments Incorporated and its subsidiaries (TI) reserve the right to make corrections, modifications, enhancements, improvements, and other changes to its products and services at any time and to discontinue any product or service without notice. Customers should obtain the latest relevant information before placing orders and should verify that such information is current and complete. All products are sold subject to TI's terms and conditions of sale supplied at the time of order acknowledgment.

TI warrants performance of its hardware products to the specifications applicable at the time of sale in accordance with TI's standard warranty. Testing and other quality control techniques are used to the extent TI deems necessary to support this warranty. Except where mandated by government requirements, testing of all parameters of each product is not necessarily performed.

TI assumes no liability for applications assistance or customer product design. Customers are responsible for their products and applications using TI components. To minimize the risks associated with customer products and applications, customers should provide adequate design and operating safeguards.

TI does not warrant or represent that any license, either express or implied, is granted under any TI patent right, copyright, mask work right, or other TI intellectual property right relating to any combination, machine, or process in which TI products or services are used. Information published by TI regarding third-party products or services does not constitute a license from TI to use such products or services or a warranty or endorsement thereof. Use of such information may require a license from a third party under the patents or other intellectual property of the third party, or a license from TI under the patents or other intellectual property of TI.

Reproduction of information in TI data books or data sheets is permissible only if reproduction is without alteration and is accompanied by all associated warranties, conditions, limitations, and notices. Reproduction of this information with alteration is an unfair and deceptive business practice. TI is not responsible or liable for such altered documentation.

Resale of TI products or services with statements different from or beyond the parameters stated by TI for that product or service voids all express and any implied warranties for the associated TI product or service and is an unfair and deceptive business practice. TI is not responsible or liable for any such statements.

Following are URLs where you can obtain information on other Texas Instruments products and application solutions:

### Products

Amplifiers	<a href="http://amplifier.ti.com">amplifier.ti.com</a>
Data Converters	<a href="http://dataconverter.ti.com">dataconverter.ti.com</a>
DSP	<a href="http://dsp.ti.com">dsp.ti.com</a>
Interface	<a href="http://interface.ti.com">interface.ti.com</a>
Logic	<a href="http://logic.ti.com">logic.ti.com</a>
Power Mgmt	<a href="http://power.ti.com">power.ti.com</a>
Microcontrollers	<a href="http://microcontroller.ti.com">microcontroller.ti.com</a>
Low Power Wireless	<a href="http://www.ti.com/lpw">www.ti.com/lpw</a>

### Applications

Audio	<a href="http://www.ti.com/audio">www.ti.com/audio</a>
Automotive	<a href="http://www.ti.com/automotive">www.ti.com/automotive</a>
Broadband	<a href="http://www.ti.com/broadband">www.ti.com/broadband</a>
Digital Control	<a href="http://www.ti.com/digitalcontrol">www.ti.com/digitalcontrol</a>
Military	<a href="http://www.ti.com/military">www.ti.com/military</a>
Optical Networking	<a href="http://www.ti.com/opticalnetwork">www.ti.com/opticalnetwork</a>
Security	<a href="http://www.ti.com/security">www.ti.com/security</a>
Telephony	<a href="http://www.ti.com/telephony">www.ti.com/telephony</a>
Video & Imaging	<a href="http://www.ti.com/video">www.ti.com/video</a>
Wireless	<a href="http://www.ti.com/wireless">www.ti.com/wireless</a>

Mailing Address: Texas Instruments  
Post Office Box 655303 Dallas, Texas 75265