

INA118

Precision, Low Power INSTRUMENTATION AMPLIFIER

FEATURES

- **LOW OFFSET VOLTAGE:** 50 μ V max
- **LOW DRIFT:** 0.5 μ V/ $^{\circ}$ C max
- **LOW INPUT BIAS CURRENT:** 5nA max
- **HIGH CMR:** 110dB min
- **INPUTS PROTECTED TO \pm 40V**
- **WIDE SUPPLY RANGE:** \pm 1.35 to \pm 18V
- **LOW QUIESCENT CURRENT:** 350 μ A
- **8-PIN PLASTIC DIP, SO-8**

APPLICATIONS

- **BRIDGE AMPLIFIER**
- **THERMOCOUPLE AMPLIFIER**
- **RTD SENSOR AMPLIFIER**
- **MEDICAL INSTRUMENTATION**
- **DATA ACQUISITION**

DESCRIPTION

The INA118 is a low power, general purpose instrumentation amplifier offering excellent accuracy. Its versatile 3-op amp design and small size make it ideal for a wide range of applications. Current-feedback input circuitry provides wide bandwidth even at high gain (70kHz at $G = 100$).

A single external resistor sets any gain from 1 to 10,000. Internal input protection can withstand up to \pm 40V without damage.

The INA118 is laser trimmed for very low offset voltage (50 μ V), drift (0.5 μ V/ $^{\circ}$ C) and high common-mode rejection (110dB at $G = 1000$). It operates with power supplies as low as \pm 1.35V, and quiescent current is only 350 μ A—ideal for battery operated systems.

The INA118 is available in 8-pin plastic DIP, and SO-8 surface-mount packages, specified for the -40° C to $+85^{\circ}$ C temperature range.

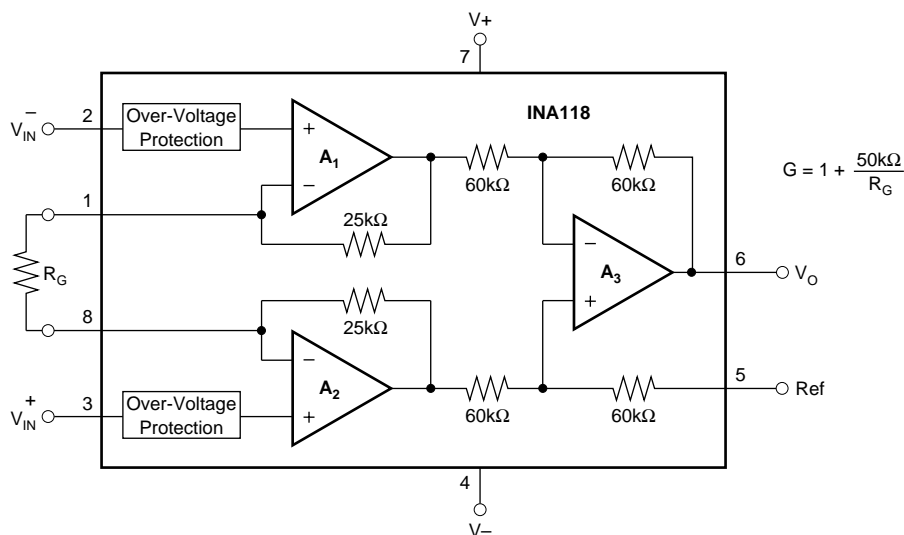

PIN CONFIGURATION

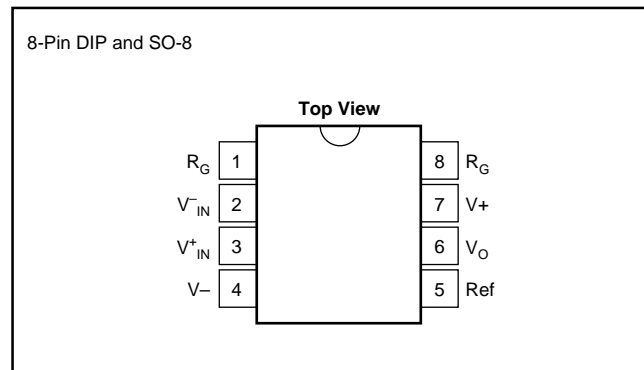

ABSOLUTE MAXIMUM RATINGS

Supply Voltage	$\pm 18V$
Analog Input Voltage Range	$\pm 40V$
Output Short-Circuit (to ground)	Continuous
Operating Temperature	$-40^\circ C$ to $+125^\circ C$
Storage Temperature	$-40^\circ C$ to $+125^\circ C$
Junction Temperature	$+150^\circ C$
Lead Temperature (soldering, 10s)	$+300^\circ C$



ELECTROSTATIC DISCHARGE SENSITIVITY

This integrated circuit can be damaged by ESD. Burr-Brown recommends that all integrated circuits be handled with appropriate precautions. Failure to observe proper handling and installation procedures can cause damage.

ESD damage can range from subtle performance degradation to complete device failure. Precision integrated circuits may be more susceptible to damage because very small parametric changes could cause the device not to meet its published specifications.

ORDERING INFORMATION

PRODUCT	PACKAGE	PACKAGE DRAWING NUMBER ⁽¹⁾	TEMPERATURE RANGE
INA118P	8-Pin Plastic DIP	006	$-40^\circ C$ to $+85^\circ C$
INA118PB	8-Pin Plastic DIP	006	$-40^\circ C$ to $+85^\circ C$
INA118U	SO-8 Surface-Mount	182	$-40^\circ C$ to $+85^\circ C$
INA118UB	SO-8 Surface-Mount	182	$-40^\circ C$ to $+85^\circ C$

NOTE: (1) For detailed drawing and dimension table, please see end of data sheet, or Appendix C of Burr-Brown IC Data Book.

The information provided herein is believed to be reliable; however, BURR-BROWN assumes no responsibility for inaccuracies or omissions. BURR-BROWN assumes no responsibility for the use of this information, and all use of such information shall be entirely at the user's own risk. Prices and specifications are subject to change without notice. No patent rights or licenses to any of the circuits described herein are implied or granted to any third party. BURR-BROWN does not authorize or warrant any BURR-BROWN product for use in life support devices and/or systems.

TYPICAL PERFORMANCE CURVES

At $T_A = +25^\circ\text{C}$, $V_S = \pm 15\text{V}$, unless otherwise noted.

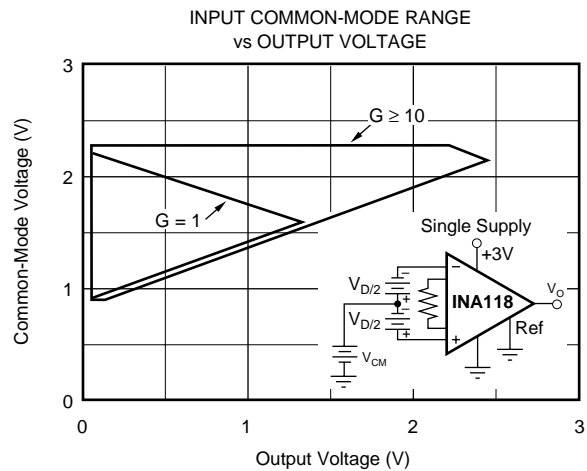
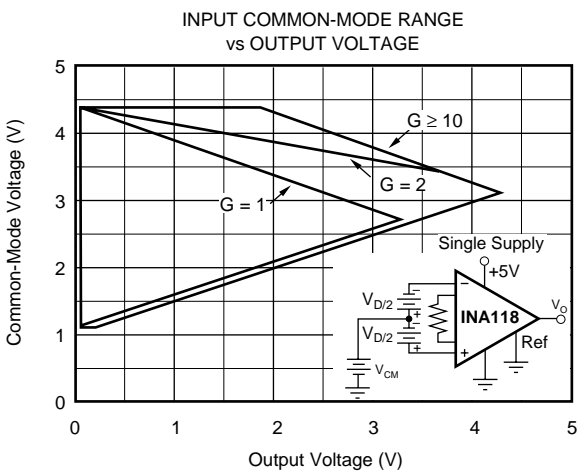
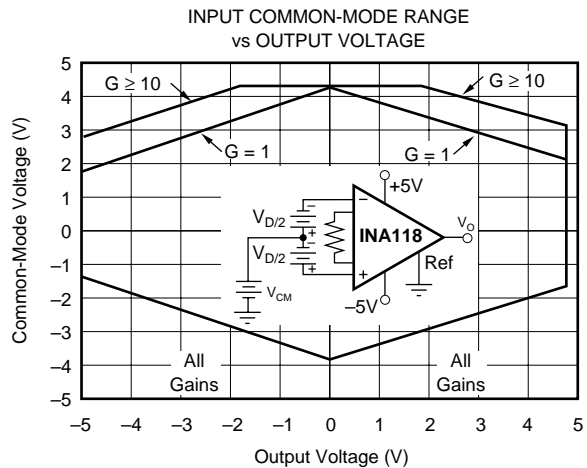
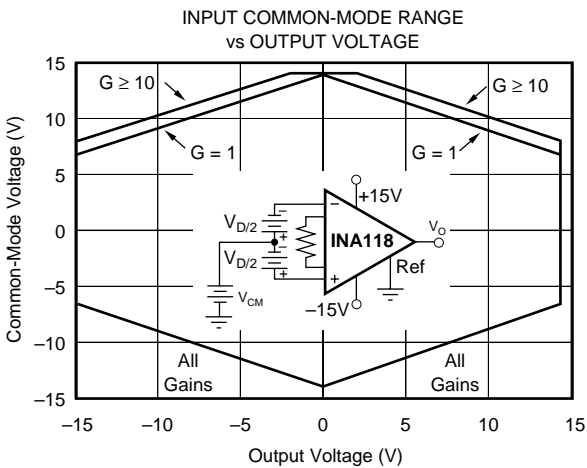
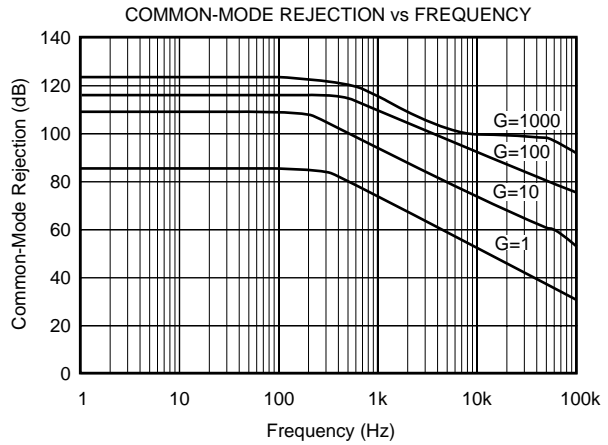
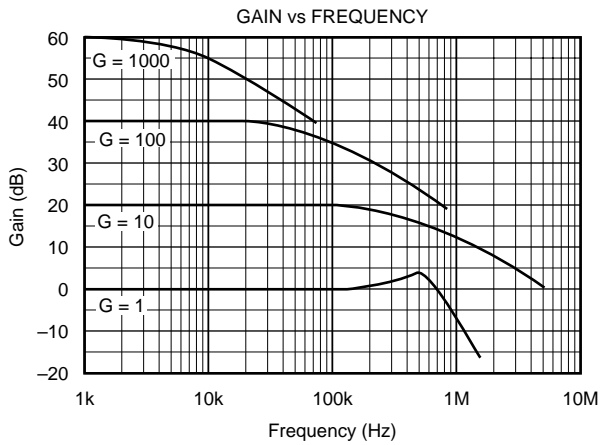

TYPICAL PERFORMANCE CURVES (CONT)

At $T_A = +25^\circ\text{C}$, $V_S = \pm 15\text{V}$, unless otherwise noted.

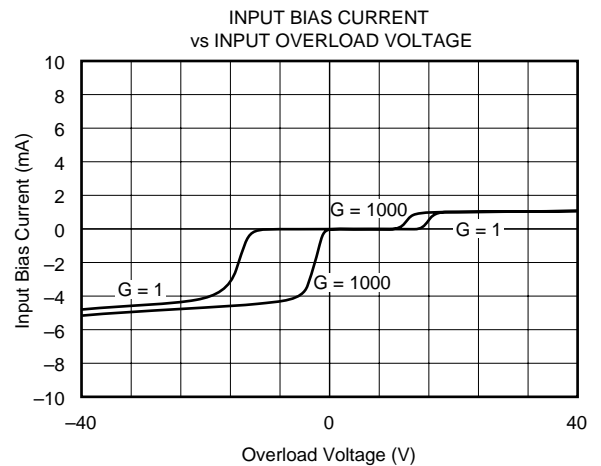
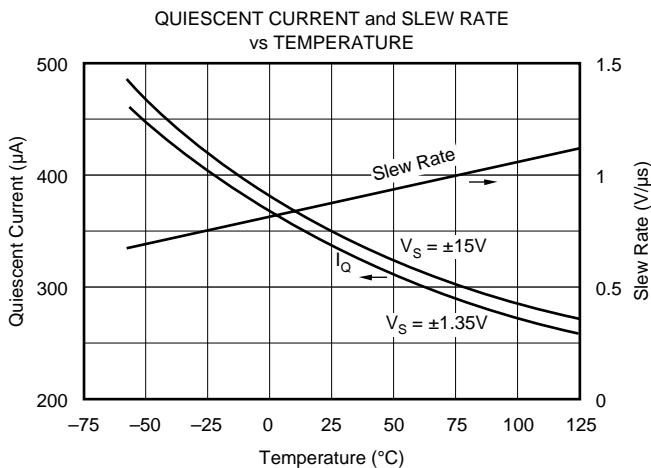
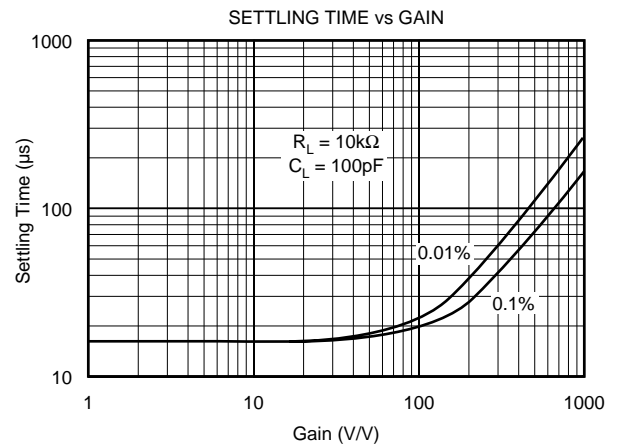
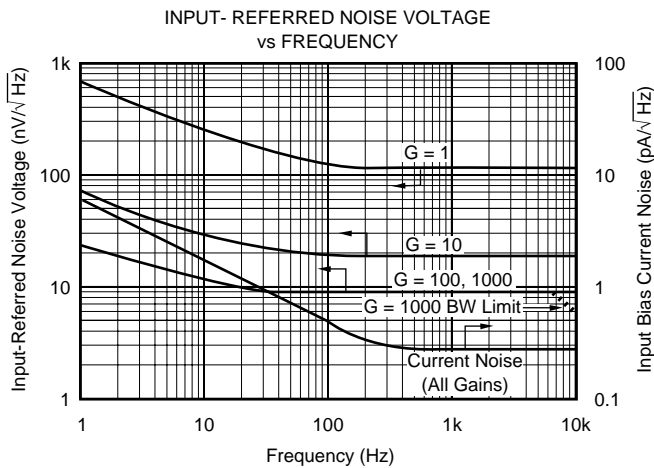
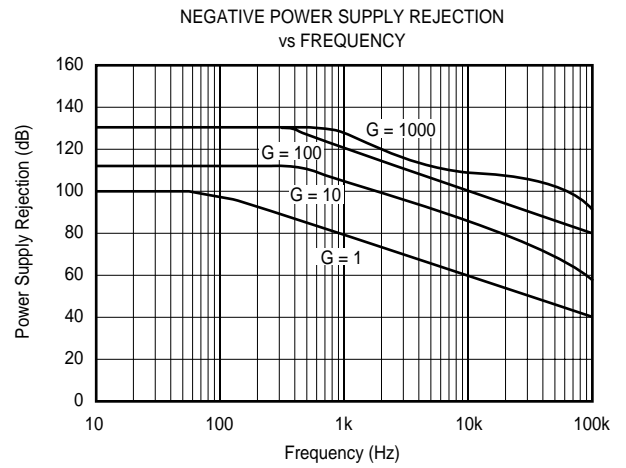
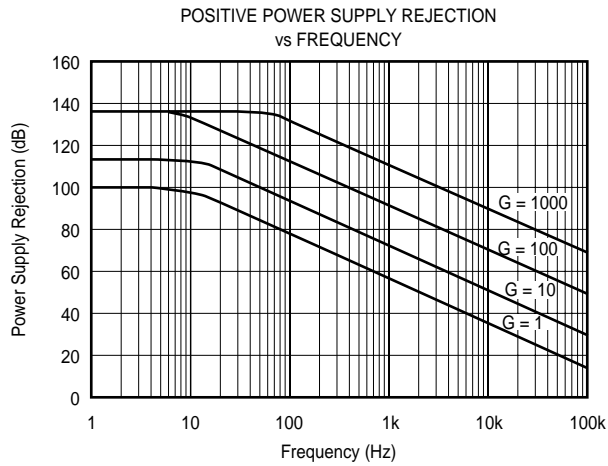

TYPICAL PERFORMANCE CURVES (CONT)

At $T_A = +25^\circ\text{C}$, $V_S = \pm 15\text{V}$, unless otherwise noted.

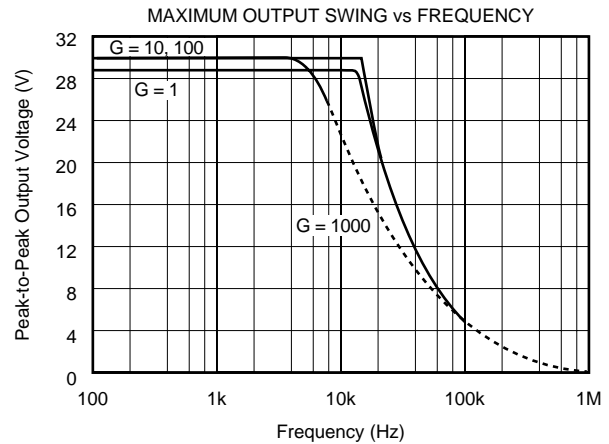
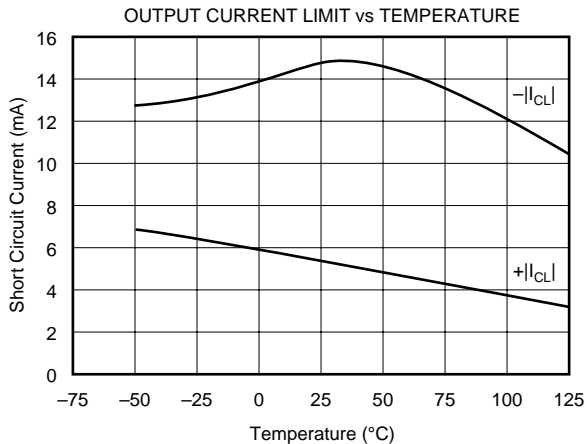
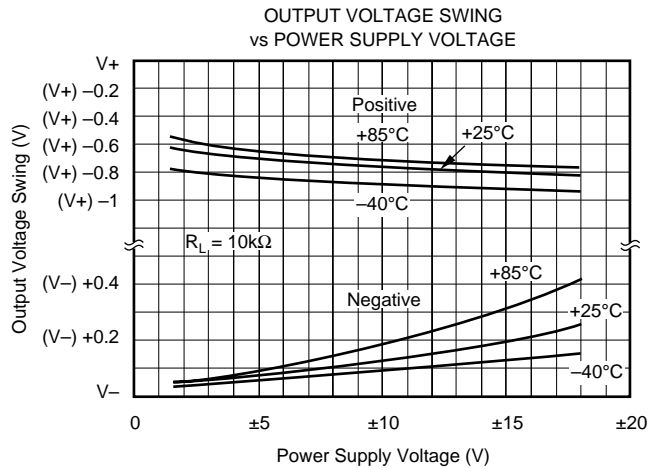
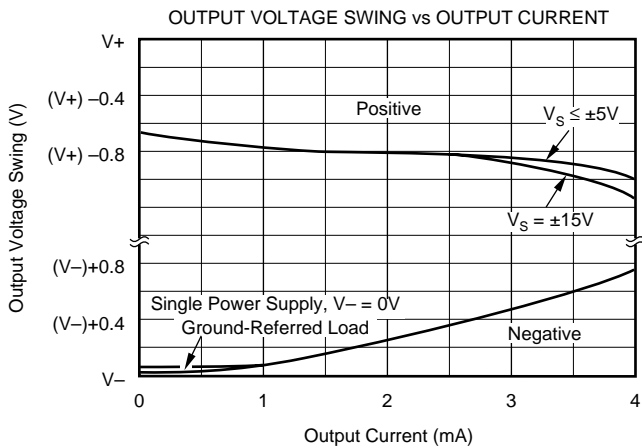
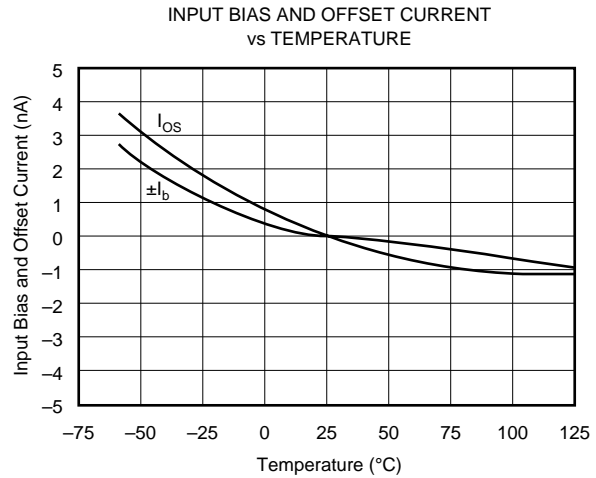
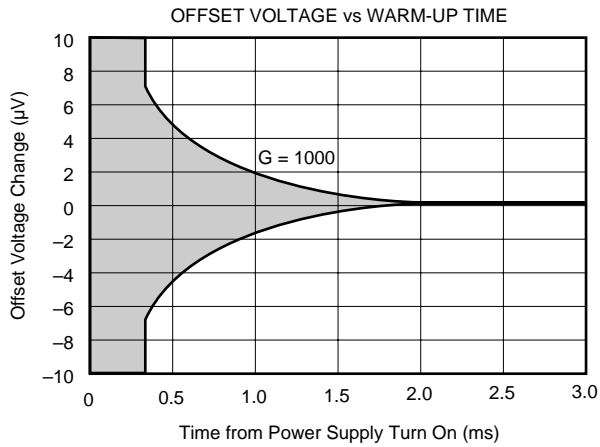

TYPICAL PERFORMANCE CURVES (CONT)

At $T_A = +25^\circ\text{C}$, $V_S = \pm 15\text{V}$, unless otherwise noted.

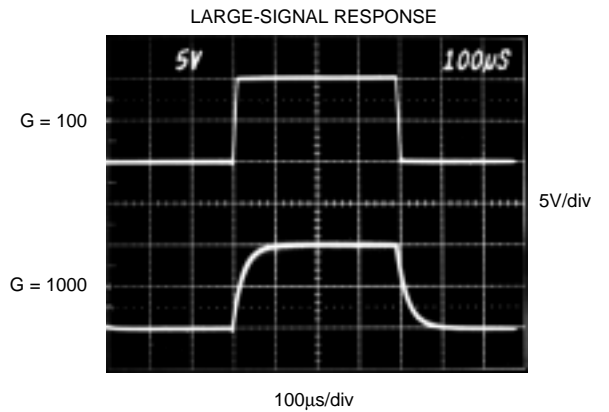
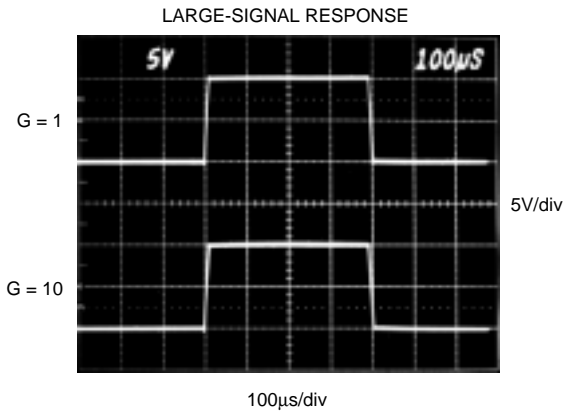
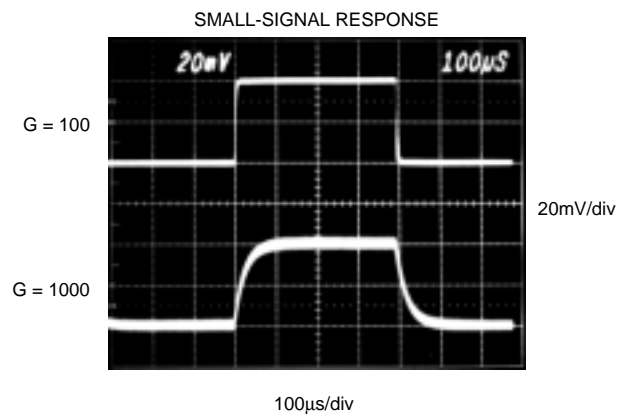
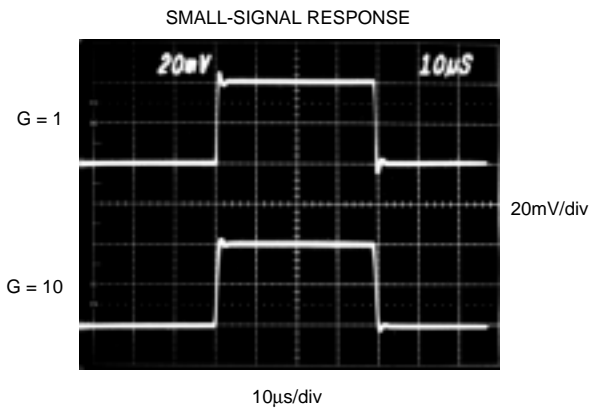
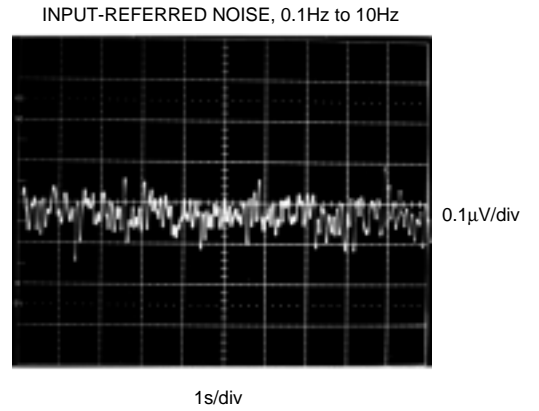
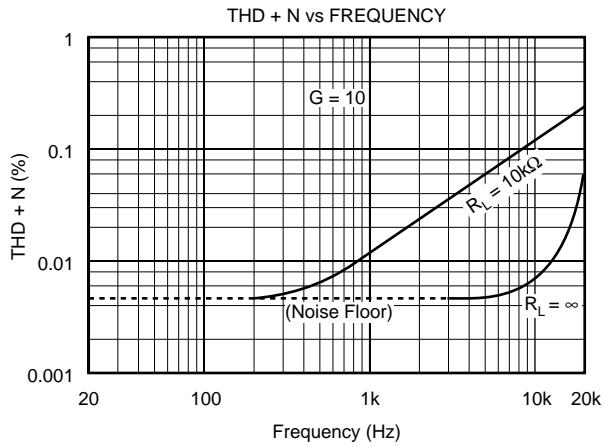

APPLICATION INFORMATION

Figure 1 shows the basic connections required for operation of the INA118. Applications with noisy or high impedance power supplies may require decoupling capacitors close to the device pins as shown.

The output is referred to the output reference (Ref) terminal which is normally grounded. This must be a low-impedance connection to assure good common-mode rejection. A resistance of 12Ω in series with the Ref pin will cause a typical device to degrade to approximately 80dB CMR ($G = 1$).

SETTING THE GAIN

Gain of the INA118 is set by connecting a single external resistor, R_G , connected between pins 1 and 8:

$$G = 1 + \frac{50k\Omega}{R_G} \quad (1)$$

Commonly used gains and resistor values are shown in Figure 1.

The 50kΩ term in Equation 1 comes from the sum of the two internal feedback resistors of A_1 and A_2 . These on-chip metal film resistors are laser trimmed to accurate absolute values. The accuracy and temperature coefficient of these resistors are included in the gain accuracy and drift specifications of the INA118.

The stability and temperature drift of the external gain setting resistor, R_G , also affects gain. R_G 's contribution to gain accuracy and drift can be directly inferred from the gain equation (1). Low resistor values required for high gain can make wiring resistance important. Sockets add to the wiring resistance which will contribute additional gain error (possibly an unstable gain error) in gains of approximately 100 or greater.

DYNAMIC PERFORMANCE

The typical performance curve "Gain vs Frequency" shows that, despite its low quiescent current, the INA118 achieves wide bandwidth, even at high gain. This is due to the current-feedback topology of the INA118. Settling time also remains excellent at high gain.

The INA118 exhibits approximately 3dB peaking at 500kHz in unity gain. This is a result of its current-feedback topology and is not an indication of instability. Unlike an op amp with poor phase margin, the rise in response is a predictable +6dB/octave due to a response zero. A simple pole at 300kHz or lower will produce a flat passband unity gain response.

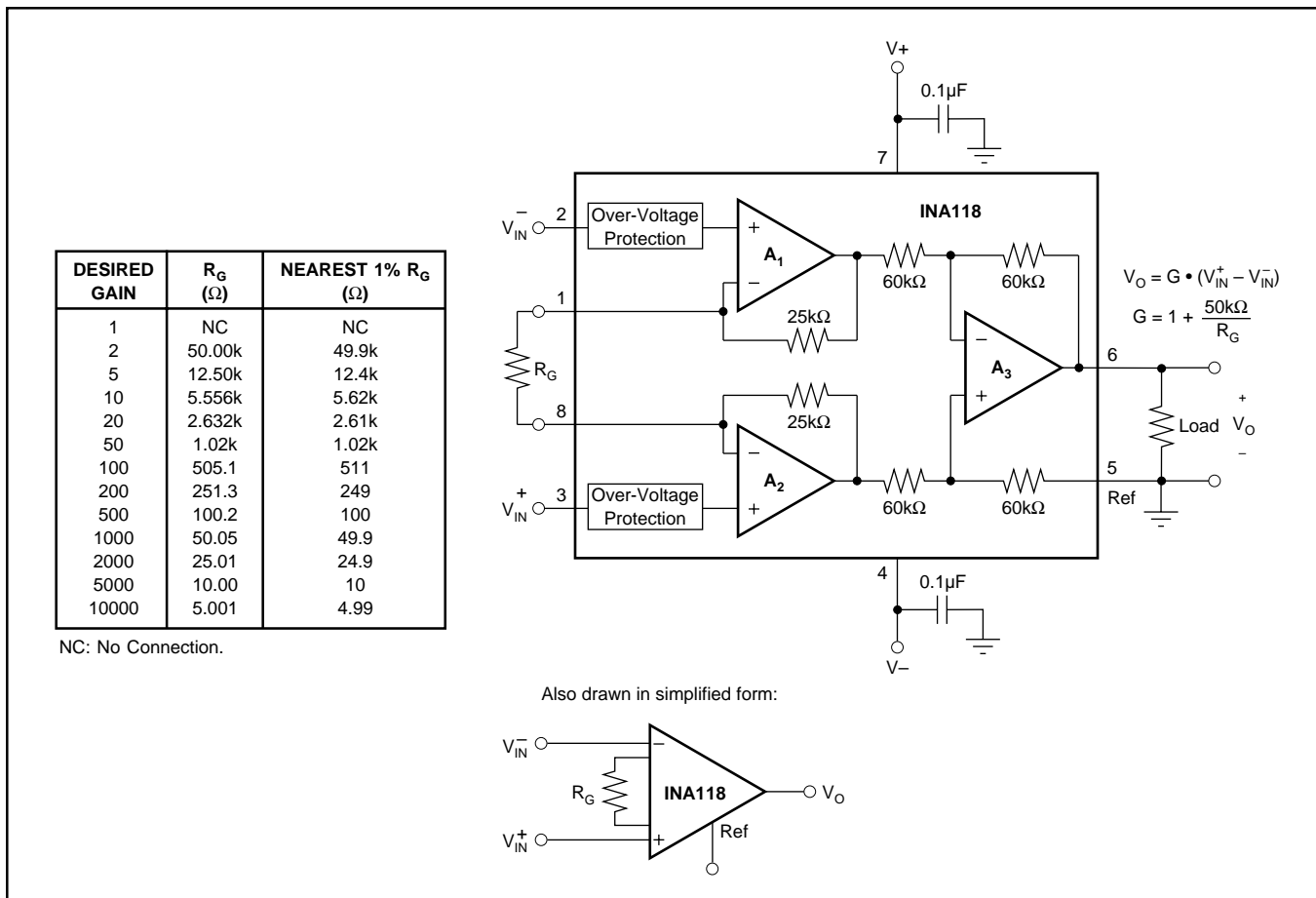

FIGURE 1. Basic Connections.

NOISE PERFORMANCE

The INA118 provides very low noise in most applications. For differential source impedances less than $1\text{k}\Omega$, the INA103 may provide lower noise. For source impedances greater than $50\text{k}\Omega$, the INA111 FET-Input Instrumentation Amplifier may provide lower noise.

Low frequency noise of the INA118 is approximately $0.28\mu\text{V}_p\text{-p}$ measured from 0.1 to 10Hz ($G \geq 100$). This provides dramatically improved noise when compared to state-of-the-art chopper-stabilized amplifiers.

OFFSET TRIMMING

The INA118 is laser trimmed for low offset voltage and drift. Most applications require no external offset adjustment. Figure 2 shows an optional circuit for trimming the output offset voltage. The voltage applied to Ref terminal is summed at the output. The op amp buffer provides low impedance at the Ref terminal to preserve good common-mode rejection.

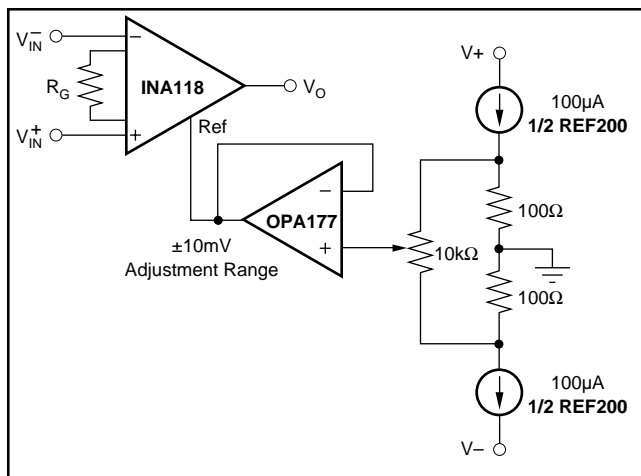

FIGURE 2. Optional Trimming of Output Offset Voltage.

INPUT BIAS CURRENT RETURN PATH

The input impedance of the INA118 is extremely high—approximately $10^{10}\Omega$. However, a path must be provided for the input bias current of both inputs. This input bias current is approximately $\pm 5\text{nA}$. High input impedance means that this input bias current changes very little with varying input voltage.

Input circuitry must provide a path for this input bias current for proper operation. Figure 3 shows various provisions for an input bias current path. Without a bias current path, the inputs will float to a potential which exceeds the common-mode range of the INA118 and the input amplifiers will saturate.

If the differential source resistance is low, the bias current return path can be connected to one input (see the thermocouple example in Figure 3). With higher source impedance, using two equal resistors provides a balanced input with possible advantages of lower input offset voltage due to bias current and better high-frequency common-mode rejection.

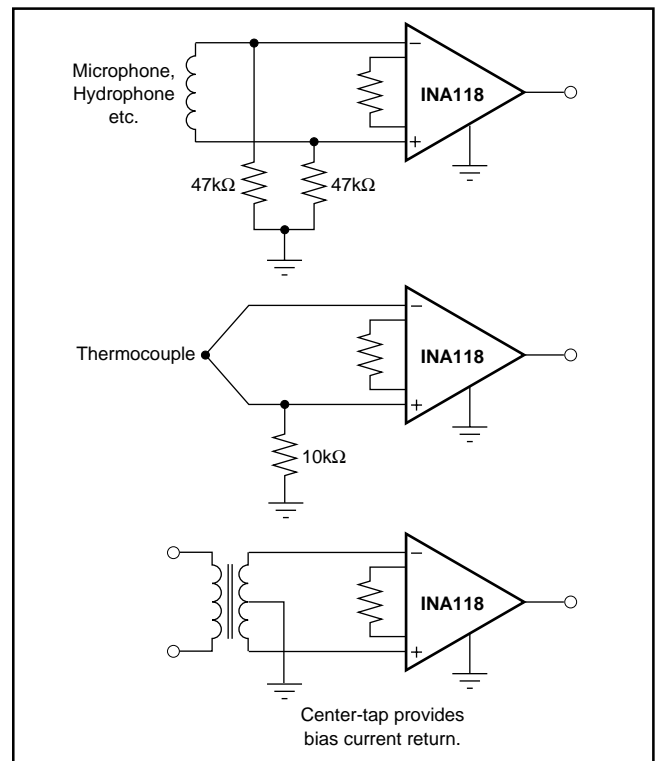

FIGURE 3. Providing an Input Common-Mode Current Path.

INPUT COMMON-MODE RANGE

The linear input voltage range of the input circuitry of the INA118 is from approximately 0.6V below the positive supply voltage to 1V above the negative supply. As a differential input voltage causes the output voltage to increase, however, the linear input range will be limited by the output voltage swing of amplifiers A_1 and A_2 . Thus, the linear common-mode input range is related to the output voltage of the complete amplifier. This behavior also depends on supply voltage—see performance curves “Input Common-Mode Range vs Output Voltage”.

Input-overload can produce an output voltage that appears normal. For example, if an input overload condition drives both input amplifiers to their positive output swing limit, the difference voltage measured by the output amplifier will be near zero. The output of the INA118 will be near 0V even though both inputs are overloaded.

LOW VOLTAGE OPERATION

The INA118 can be operated on power supplies as low as $\pm 1.35\text{V}$. Performance of the INA118 remains excellent with power supplies ranging from $\pm 1.35\text{V}$ to $\pm 18\text{V}$. Most parameters vary only slightly throughout this supply voltage range—see typical performance curves. Operation at very low supply voltage requires careful attention to assure that the input voltages remain within their linear range. Voltage swing requirements of internal nodes limit the input common-mode range with low power supply voltage. Typical performance curves, “Input Common-Mode Range vs Output Voltage” show the range of linear operation for a various supply voltages and gains.

SINGLE SUPPLY OPERATION

The INA118 can be used on single power supplies of +2.7V to +36V. Figure 5 shows a basic single supply circuit. The output Ref terminal is connected to ground. Zero differential input voltage will demand an output voltage of 0V (ground). Actual output voltage swing is limited to approximately 35mV above ground, when the load is referred to ground as shown. The typical performance curve “Output Voltage vs Output Current” shows how the output voltage swing varies with output current.

With single supply operation, V_{IN}^+ and V_{IN}^- must both be 0.98V above ground for linear operation. You cannot, for instance, connect the inverting input to ground and measure a voltage connected to the non-inverting input.

To illustrate the issues affecting low voltage operation, consider the circuit in Figure 5. It shows the INA118, operating from a single 3V supply. A resistor in series with the low side of the bridge assures that the bridge output

voltage is within the common-mode range of the amplifier’s inputs. Refer to the typical performance curve “Input Common-Mode Range vs Output Voltage” for 3V single supply operation.

INPUT PROTECTION

The inputs of the INA118 are individually protected for voltages up to $\pm 40V$. For example, a condition of $-40V$ on one input and $+40V$ on the other input will not cause damage. Internal circuitry on each input provides low series impedance under normal signal conditions. To provide equivalent protection, series input resistors would contribute excessive noise. If the input is overloaded, the protection circuitry limits the input current to a safe value of approximately 1.5 to 5mA. The typical performance curve “Input Bias Current vs Input Overload Voltage” shows this input current limit behavior. The inputs are protected even if the power supplies are disconnected or turned off.

INSIDE THE INA118

Figure 1 shows a simplified representation of the INA118. The more detailed diagram shown here provides additional insight into its operation.

Each input is protected by two FET transistors that provide a low series resistance under normal signal conditions, preserving excellent noise performance. When excessive voltage is applied, these transistors limit input current to approximately 1.5 to 5mA.

The differential input voltage is buffered by Q_1 and Q_2 and impressed across R_G , causing a signal current to flow through R_G , R_1 and R_2 . The output difference amp, A_3 , removes the common-mode component of the input signal and refers the output signal to the Ref terminal.

Equations in the figure describe the output voltages of A_1 and A_2 . The V_{BE} and IR drop across R_1 and R_2 produce output voltages on A_1 and A_2 that are approximately 1V lower than the input voltages.

$$A_1 \text{ Out} = V_{CM} - V_{BE} - (10\mu A \cdot 25k\Omega) - V_O/2$$

$$A_2 \text{ Out} = V_{CM} - V_{BE} - (10\mu A \cdot 25k\Omega) + V_O/2$$

$$\text{Output Swing Range } A_1, A_2: (V+) - 0.65V \text{ to } (V-) + 0.06V$$

$$\text{Amplifier Linear Input Range: } (V+) - 0.65V \text{ to } (V-) + 0.98V$$

$$V_O = G \cdot (V_{IN}^+ - V_{IN}^-)$$

$$\text{Output Swing Range: } (V+) - 0.8V \text{ to } (V-) + 0.35V$$

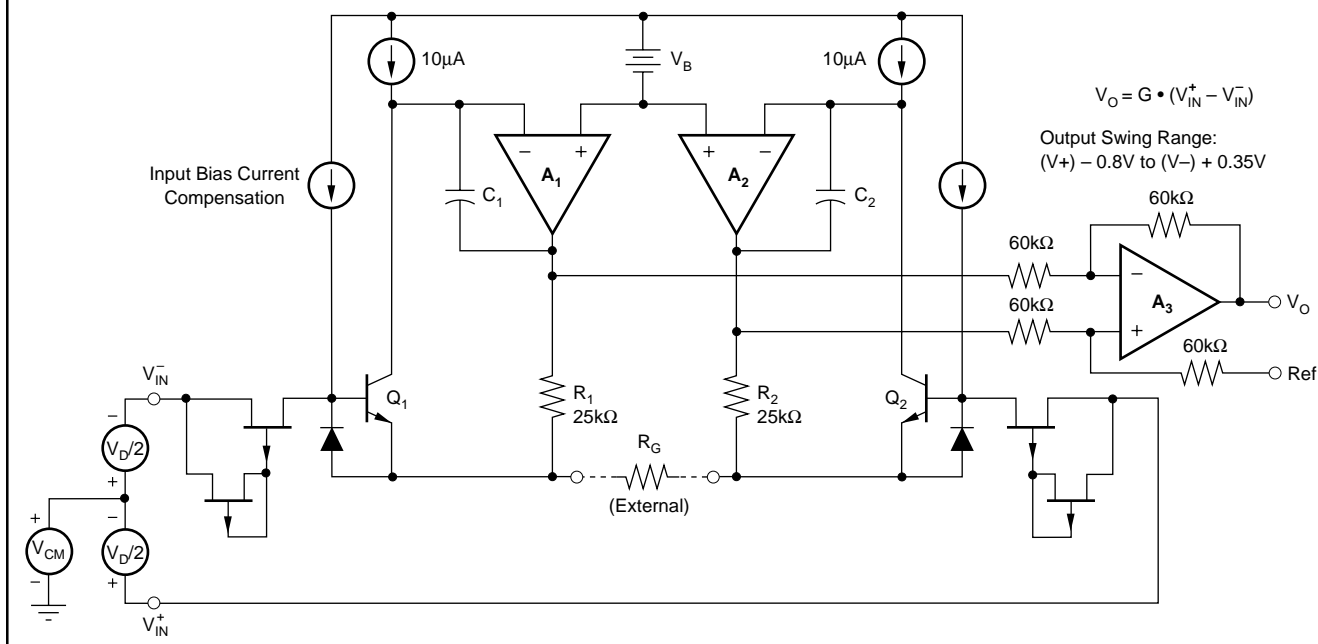

FIGURE 4. INA118 Simplified Circuit Diagram.

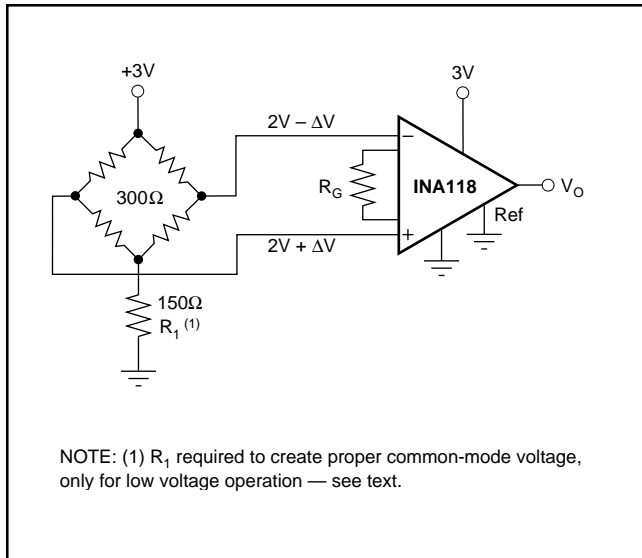

FIGURE 5. Single-Supply Bridge Amplifier.

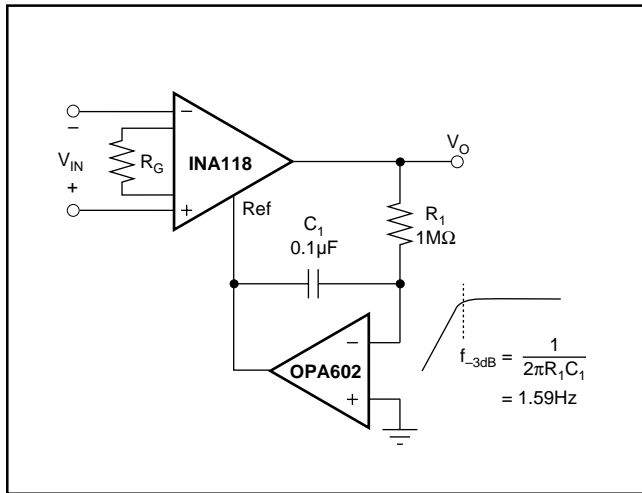

FIGURE 6. AC-Coupled Instrumentation Amplifier.

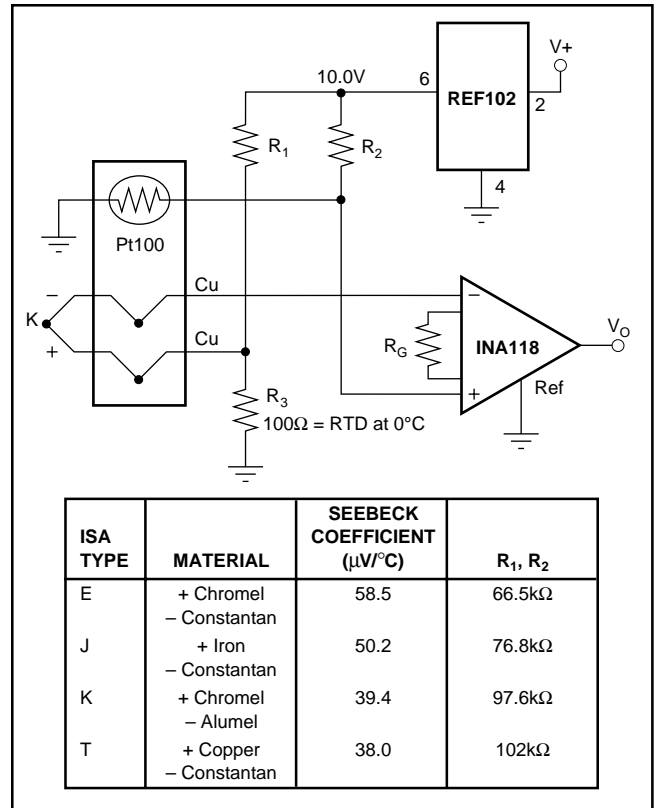

FIGURE 7. Thermocouple Amplifier With Cold Junction Compensation.

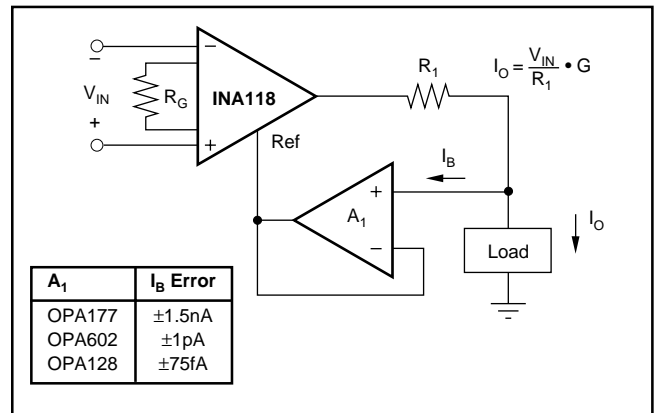

FIGURE 8. Differential Voltage to Current Converter.

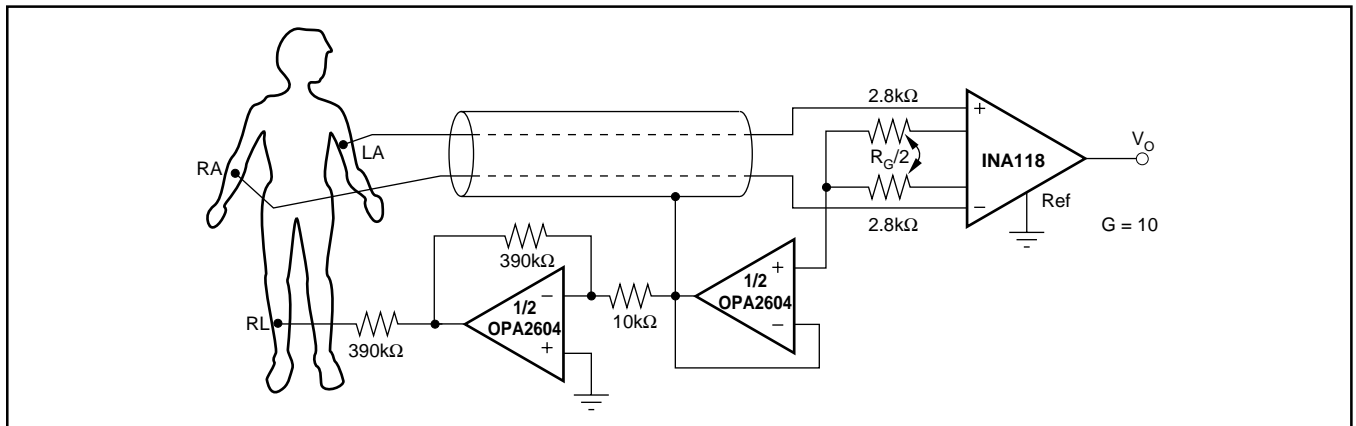

FIGURE 9. ECG Amplifier With Right-Leg Drive.

PACKAGING INFORMATION

Orderable Device	Status ⁽¹⁾	Package Type	Package Drawing	Pins	Package Qty	Eco Plan ⁽²⁾	Lead/Ball Finish	MSL Peak Temp ⁽³⁾
INA118P	ACTIVE	PDIP	P	8	50	Green (RoHS & no Sb/Br)	CU NIPDAU	N / A for Pkg Type
INA118PB	ACTIVE	PDIP	P	8	50	Green (RoHS & no Sb/Br)	CU NIPDAU	N / A for Pkg Type
INA118PBG4	ACTIVE	PDIP	P	8	50	Green (RoHS & no Sb/Br)	CU NIPDAU	N / A for Pkg Type
INA118PG4	ACTIVE	PDIP	P	8	50	Green (RoHS & no Sb/Br)	CU NIPDAU	N / A for Pkg Type
INA118U	ACTIVE	SOIC	D	8	75	Green (RoHS & no Sb/Br)	CU NIPDAU	Level-3-260C-168 HR
INA118U/2K5	ACTIVE	SOIC	D	8	2500	Green (RoHS & no Sb/Br)	CU NIPDAU	Level-3-260C-168 HR
INA118U/2K5G4	ACTIVE	SOIC	D	8	2500	Green (RoHS & no Sb/Br)	CU NIPDAU	Level-3-260C-168 HR
INA118UB	ACTIVE	SOIC	D	8	75	Green (RoHS & no Sb/Br)	CU NIPDAU	Level-3-260C-168 HR
INA118UB/2K5	ACTIVE	SOIC	D	8	2500	Green (RoHS & no Sb/Br)	CU NIPDAU	Level-3-260C-168 HR
INA118UB/2K5G4	ACTIVE	SOIC	D	8	2500	Green (RoHS & no Sb/Br)	CU NIPDAU	Level-3-260C-168 HR
INA118UBG4	ACTIVE	SOIC	D	8	75	Green (RoHS & no Sb/Br)	CU NIPDAU	Level-3-260C-168 HR
INA118UG4	ACTIVE	SOIC	D	8	75	Green (RoHS & no Sb/Br)	CU NIPDAU	Level-3-260C-168 HR

⁽¹⁾ The marketing status values are defined as follows:

ACTIVE: Product device recommended for new designs.

LIFEBUY: TI has announced that the device will be discontinued, and a lifetime-buy period is in effect.

NRND: Not recommended for new designs. Device is in production to support existing customers, but TI does not recommend using this part in a new design.

PREVIEW: Device has been announced but is not in production. Samples may or may not be available.

OBSOLETE: TI has discontinued the production of the device.

⁽²⁾ Eco Plan - The planned eco-friendly classification: Pb-Free (RoHS), Pb-Free (RoHS Exempt), or Green (RoHS & no Sb/Br) - please check <http://www.ti.com/productcontent> for the latest availability information and additional product content details.

TBD: The Pb-Free/Green conversion plan has not been defined.

Pb-Free (RoHS): TI's terms "Lead-Free" or "Pb-Free" mean semiconductor products that are compatible with the current RoHS requirements for all 6 substances, including the requirement that lead not exceed 0.1% by weight in homogeneous materials. Where designed to be soldered at high temperatures, TI Pb-Free products are suitable for use in specified lead-free processes.

Pb-Free (RoHS Exempt): This component has a RoHS exemption for either 1) lead-based flip-chip solder bumps used between the die and package, or 2) lead-based die adhesive used between the die and leadframe. The component is otherwise considered Pb-Free (RoHS compatible) as defined above.

Green (RoHS & no Sb/Br): TI defines "Green" to mean Pb-Free (RoHS compatible), and free of Bromine (Br) and Antimony (Sb) based flame retardants (Br or Sb do not exceed 0.1% by weight in homogeneous material)

⁽³⁾ MSL, Peak Temp. -- The Moisture Sensitivity Level rating according to the JEDEC industry standard classifications, and peak solder temperature.

Important Information and Disclaimer: The information provided on this page represents TI's knowledge and belief as of the date that it is provided. TI bases its knowledge and belief on information provided by third parties, and makes no representation or warranty as to the accuracy of such information. Efforts are underway to better integrate information from third parties. TI has taken and continues to take reasonable steps to provide representative and accurate information but may not have conducted destructive testing or chemical analysis on incoming materials and chemicals. TI and TI suppliers consider certain information to be proprietary, and thus CAS numbers and other limited information may not be available for release.

In no event shall TI's liability arising out of such information exceed the total purchase price of the TI part(s) at issue in this document sold by TI to Customer on an annual basis.

TAPE AND REEL INFORMATION

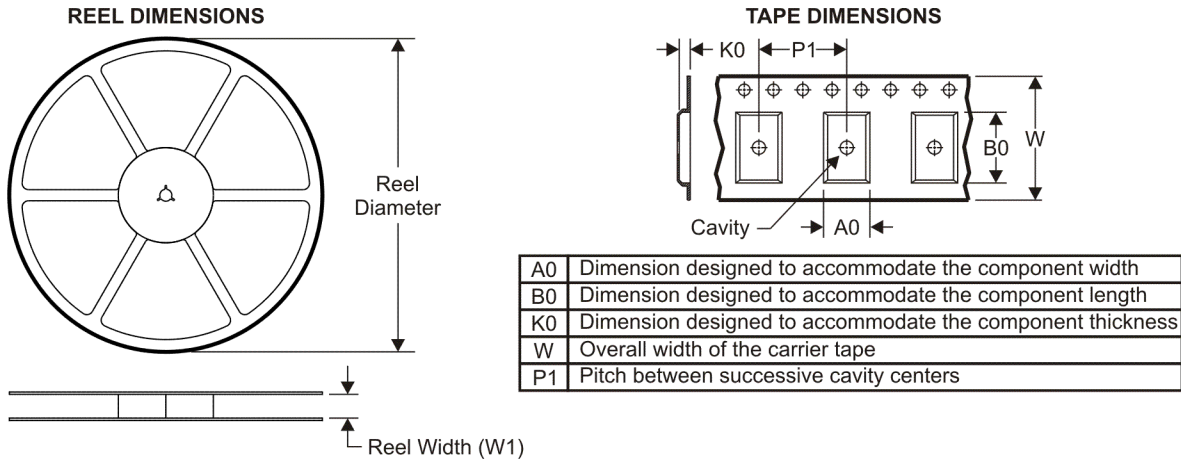

QUADRANT ASSIGNMENTS FOR PIN 1 ORIENTATION IN TAPE



*All dimensions are nominal

Device	Package Type	Package Drawing	Pins	SPQ	Reel Diameter (mm)	Reel Width W1 (mm)	A0 (mm)	B0 (mm)	K0 (mm)	P1 (mm)	W (mm)	Pin1 Quadrant
INA118U/2K5	SOIC	D	8	2500	330.0	12.4	6.4	5.2	2.1	8.0	12.0	Q1
INA118UB/2K5	SOIC	D	8	2500	330.0	12.4	6.4	5.2	2.1	8.0	12.0	Q1

TAPE AND REEL BOX DIMENSIONS



*All dimensions are nominal

Device	Package Type	Package Drawing	Pins	SPQ	Length (mm)	Width (mm)	Height (mm)
INA118U/2K5	SOIC	D	8	2500	346.0	346.0	29.0
INA118UB/2K5	SOIC	D	8	2500	346.0	346.0	29.0

IMPORTANT NOTICE

Texas Instruments Incorporated and its subsidiaries (TI) reserve the right to make corrections, modifications, enhancements, improvements, and other changes to its products and services at any time and to discontinue any product or service without notice. Customers should obtain the latest relevant information before placing orders and should verify that such information is current and complete. All products are sold subject to TI's terms and conditions of sale supplied at the time of order acknowledgment.

TI warrants performance of its hardware products to the specifications applicable at the time of sale in accordance with TI's standard warranty. Testing and other quality control techniques are used to the extent TI deems necessary to support this warranty. Except where mandated by government requirements, testing of all parameters of each product is not necessarily performed.

TI assumes no liability for applications assistance or customer product design. Customers are responsible for their products and applications using TI components. To minimize the risks associated with customer products and applications, customers should provide adequate design and operating safeguards.

TI does not warrant or represent that any license, either express or implied, is granted under any TI patent right, copyright, mask work right, or other TI intellectual property right relating to any combination, machine, or process in which TI products or services are used. Information published by TI regarding third-party products or services does not constitute a license from TI to use such products or services or a warranty or endorsement thereof. Use of such information may require a license from a third party under the patents or other intellectual property of the third party, or a license from TI under the patents or other intellectual property of TI.

Reproduction of TI information in TI data books or data sheets is permissible only if reproduction is without alteration and is accompanied by all associated warranties, conditions, limitations, and notices. Reproduction of this information with alteration is an unfair and deceptive business practice. TI is not responsible or liable for such altered documentation. Information of third parties may be subject to additional restrictions.

Resale of TI products or services with statements different from or beyond the parameters stated by TI for that product or service voids all express and any implied warranties for the associated TI product or service and is an unfair and deceptive business practice. TI is not responsible or liable for any such statements.

TI products are not authorized for use in safety-critical applications (such as life support) where a failure of the TI product would reasonably be expected to cause severe personal injury or death, unless officers of the parties have executed an agreement specifically governing such use. Buyers represent that they have all necessary expertise in the safety and regulatory ramifications of their applications, and acknowledge and agree that they are solely responsible for all legal, regulatory and safety-related requirements concerning their products and any use of TI products in such safety-critical applications, notwithstanding any applications-related information or support that may be provided by TI. Further, Buyers must fully indemnify TI and its representatives against any damages arising out of the use of TI products in such safety-critical applications.

TI products are neither designed nor intended for use in military/aerospace applications or environments unless the TI products are specifically designated by TI as military-grade or "enhanced plastic." Only products designated by TI as military-grade meet military specifications. Buyers acknowledge and agree that any such use of TI products which TI has not designated as military-grade is solely at the Buyer's risk, and that they are solely responsible for compliance with all legal and regulatory requirements in connection with such use.

TI products are neither designed nor intended for use in automotive applications or environments unless the specific TI products are designated by TI as compliant with ISO/TS 16949 requirements. Buyers acknowledge and agree that, if they use any non-designated products in automotive applications, TI will not be responsible for any failure to meet such requirements.

Following are URLs where you can obtain information on other Texas Instruments products and application solutions:

Products

Amplifiers	amplifier.ti.com
Data Converters	dataconverter.ti.com
DLP® Products	www.dlp.com
DSP	dsp.ti.com
Clocks and Timers	www.ti.com/clocks
Interface	interface.ti.com
Logic	logic.ti.com
Power Mgmt	power.ti.com
Microcontrollers	microcontroller.ti.com
RFID	www.ti-rfid.com
RF/IF and ZigBee® Solutions	www.ti.com/lprf

Applications

Audio	www.ti.com/audio
Automotive	www.ti.com/automotive
Broadband	www.ti.com/broadband
Digital Control	www.ti.com/digitalcontrol
Medical	www.ti.com/medical
Military	www.ti.com/military
Optical Networking	www.ti.com/opticalnetwork
Security	www.ti.com/security
Telephony	www.ti.com/telephony
Video & Imaging	www.ti.com/video
Wireless	www.ti.com/wireless

Mailing Address: Texas Instruments, Post Office Box 655303, Dallas, Texas 75265
Copyright © 2009, Texas Instruments Incorporated