

www.ti.com

High Common-Mode Voltage DIFFERENCE AMPLIFIER

FEATURES

- COMMON-MODE INPUT RANGE:
 $\pm 200\text{V}$ ($V_S = \pm 15\text{V}$)
- PROTECTED INPUTS:
 $\pm 500\text{V}$ Common-Mode
 $\pm 500\text{V}$ Differential
- UNITY GAIN: 0.02% Gain Error max
- NONLINEARITY: 0.001% max
- CMRR: 86dB min

APPLICATIONS

- CURRENT MONITOR
- BATTERY CELL-VOLTAGE MONITOR
- GROUND BREAKER
- INPUT PROTECTION
- SIGNAL ACQUISITION IN NOISY ENVIRONMENTS
- FACTORY AUTOMATION

DESCRIPTION

The INA117 is a precision unity-gain difference amplifier with very high common-mode input voltage range. It is a single monolithic IC consisting of a precision op amp and integrated thin-film resistor network. It can accurately measure small differential voltages in the presence of common-mode signals up to $\pm 200\text{V}$. The INA117 inputs are protected from momentary common-mode or differential overloads up to $\pm 500\text{V}$.

In many applications, where galvanic isolation is not essential, the INA117 can replace isolation amplifiers. This can eliminate costly isolated input-side power supplies and their associated ripple, noise and quiescent current. The INA117's 0.001% nonlinearity and 200kHz bandwidth are superior to those of conventional isolation amplifiers.

The INA117 is available in 8-pin plastic mini-DIP and SO-8 surface-mount packages, specified for the -40°C to $+85^\circ\text{C}$ temperature range. The metal TO-99 models are available specified for the -40°C to $+85^\circ\text{C}$ and -55°C to $+125^\circ\text{C}$ temperature range.

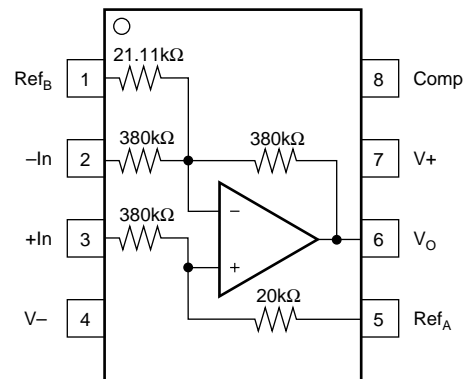

SPECIFICATIONS

At $T_A = +25^\circ\text{C}$, $V_S = \pm 15\text{V}$, unless otherwise noted.

PARAMETER	CONDITIONS	INA117AM, SM			INA117BM			INA117P, KU			UNITS
		MIN	TYP	MAX	MIN	TYP	MAX	MIN	TYP	MAX	
GAIN Initial ⁽¹⁾ Error vs Temperature Nonlinearity ⁽²⁾			1 0.01 2 0.0002			*			*	*	V/V % ppm/°C %
OUTPUT Rated Voltage Rated Current Impedance Current Limit Capacitive Load	$I_O = +20\text{mA}, -5\text{mA}$ $V_O = 10\text{V}$ To Common Stable Operation	10 +20, -5	12 0.01 +49, -13 1000		*	*		*	*		V mA Ω mA pF
INPUT Impedance Voltage Range Common-Mode Rejection ⁽³⁾ DC AC, 60Hz vs Temperature, DC AM, BM, P, KU SM	Differential Common-Mode Differential Common-Mode, Continuous $V_{CM} = 400\text{Vp-p}$ $T_A = T_{MIN}$ to T_{MAX}	 ± 10 ± 200 70 66 66 60	800 400 80 80 75 75			*	*	*	*	*	k Ω k Ω V V dB dB dB dB
OFFSET VOLTAGE Initial KU Grade (SO-8 Package) vs Temperature vs Supply vs Time	RTO ⁽⁴⁾ $T_A = T_{MIN}$ to T_{MAX} $V_S = \pm 5\text{V}$ to $\pm 18\text{V}$		120 8.5 90 200	1000 40		*	1000 40 *		*	* 600 *	μV μV $\mu\text{V}/^\circ\text{C}$ dB $\mu\text{V}/\text{mo}$
OUTPUT NOISE VOLTAGE $f_B = 0.01\text{Hz}$ to 10Hz $f_B = 10\text{kHz}$	RTO ⁽⁵⁾		25 550			*	*		*	*	$\mu\text{Vp-p}$ nV/ $\sqrt{\text{Hz}}$
DYNAMIC RESPONSE Gain Bandwidth, -3dB Full Power Bandwidth Slew Rate Settling Time: 0.1% 0.01% 0.01%	$V_O = 20\text{Vp-p}$ $V_O = 10\text{V}$ Step $V_O = 10\text{V}$ Step $V_{CM} = 10\text{V}$ Step, $V_{DIFF} = 0\text{V}$	30 2	200 2.6 6.5 10 4.5		*	*	*	*	*	*	kHz kHz V/ μs μs μs μs
POWER SUPPLY Rated Voltage Range Quiescent Current	Derated Performance $V_O = 0\text{V}$	± 5	± 15 1.5	± 18 2	*	*	*	*	*	*	V V mA
TEMPERATURE RANGE Specification: AM, BM, P, KU SM Operation Storage		-25 -55 -55 -65		+85 +125 +125 +150	*	*	*	-40 -40 -55		+85 +85 +125	°C °C °C °C

*Specification same as for INA117AM.

NOTES: (1) Connected as difference amplifier (see Figure 1). (2) Nonlinearity is the maximum peak deviation from the best-fit straight line as a percent of full-scale peak-to-peak output. (3) With zero source impedance (see discussion of common-mode rejection in Application Information section). (4) Includes effects of amplifier's input bias and offset currents. (5) Includes effects of amplifier's input current noise and thermal noise contribution of resistor network.

PIN CONFIGURATION

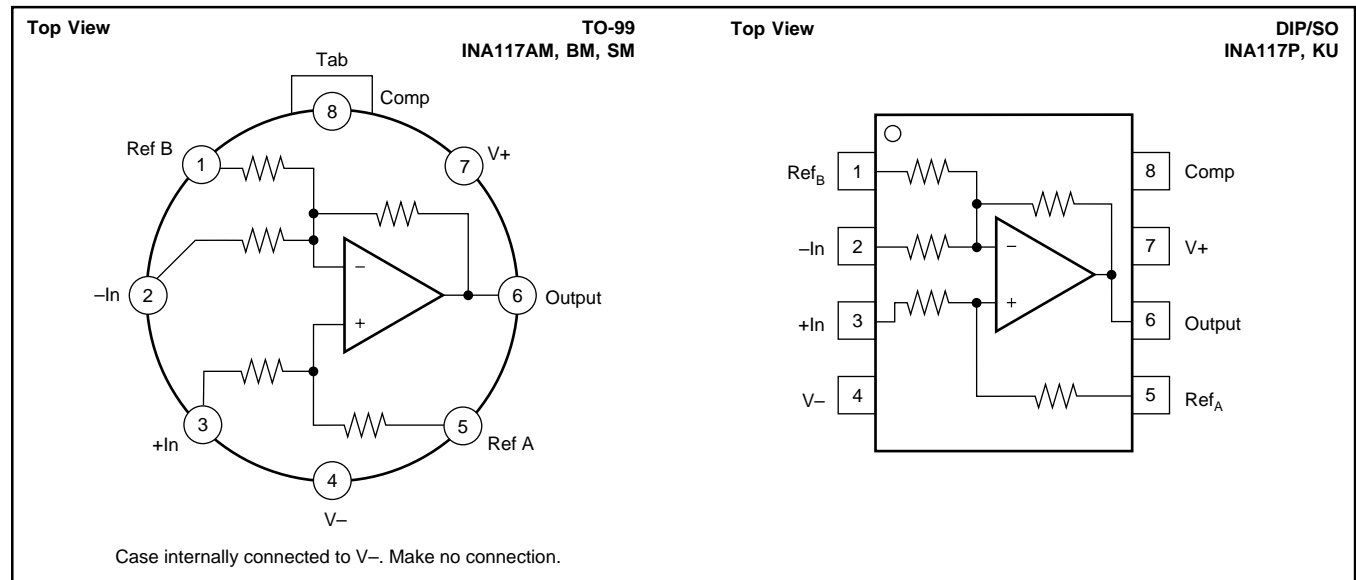

ABSOLUTE MAXIMUM RATINGS

Supply Voltage	±22V
Input Voltage Range, Continuous	±200V
Common-Mode and Differential, 10s	±500V
Operating Temperature	
M Metal TO-99	-55 to +125°C
P Plastic DIP and U SO-8	-40 to +85°C
Storage Temperature	
M Package	-65 to +150°C
P Plastic DIP and U SO-8	-55 to +125°C
Lead Temperature (soldering, 10s)	+300°C
Output Short Circuit to Common	Continuous



ELECTROSTATIC DISCHARGE SENSITIVITY

This integrated circuit can be damaged by ESD. Texas Instruments recommends that all integrated circuits be handled with appropriate precautions. Failure to observe proper handling and installation procedures can cause damage.

ESD damage can range from subtle performance degradation to complete device failure. Precision integrated circuits may be more susceptible to damage because very small parametric changes could cause the device not to meet its published specifications.

PACKAGE/ORDERING INFORMATION

PRODUCT	PACKAGE	PACKAGE DRAWING NUMBER	SPECIFIED TEMPERATURE RANGE	PACKAGE MARKING	ORDERING NUMBER ⁽¹⁾	TRANSPORT MEDIA
INA117P	DIP-8	006	-40°C to +85°C	INA117P	INA117P	Rails
INA117KU	SO-8 Surface-Mount	182	"	INA117KU	INA117KU	Rails
"	"	"	"	"	INA117KU/2K5	Tape and Reel
INA117AM	TO-99 Metal	001	-25°C to +85°C	INA117AM	INA117AM	Rails
INA117BM	"	"	"	INA117BM	INA117BM	Rails
INA117SM	"	"	-55°C to +125°C	INA117SM	INA117SM	Rails

NOTE: (1) Models with a slash (/) are available only in Tape and Reel in the quantities indicated (e.g., /2K5 indicates 2500 devices per reel). Ordering 2500 pieces of "INA117KU/2K5" will get a single 2500-piece Tape and Reel.

TYPICAL PERFORMANCE CURVES

At $T_A = +25^\circ\text{C}$, $V_S = \pm 15\text{V}$, unless otherwise noted.

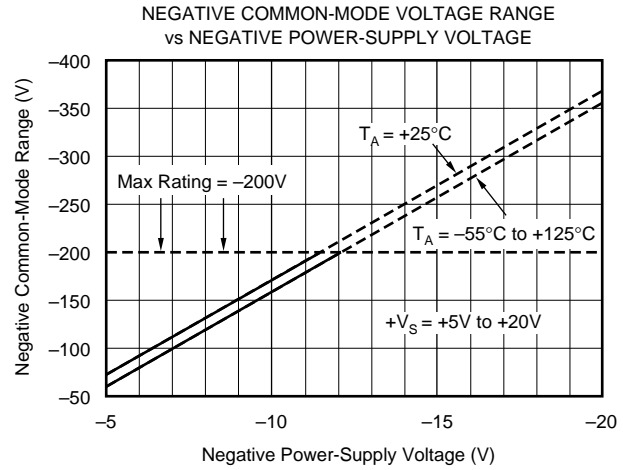
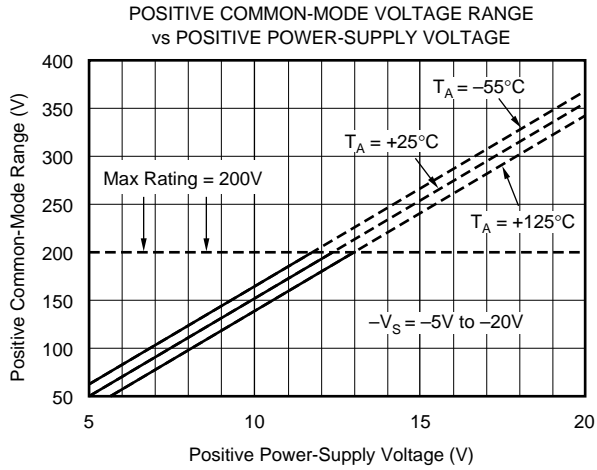
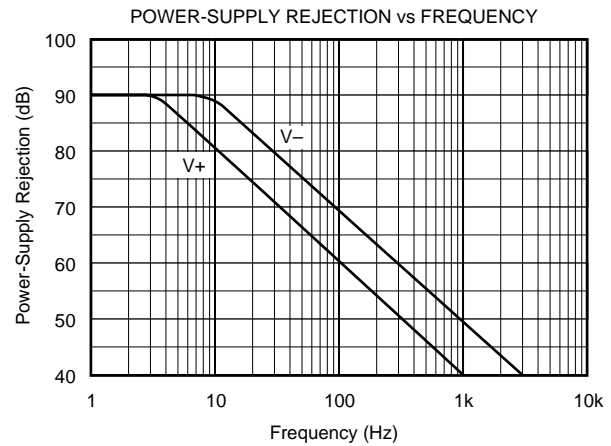
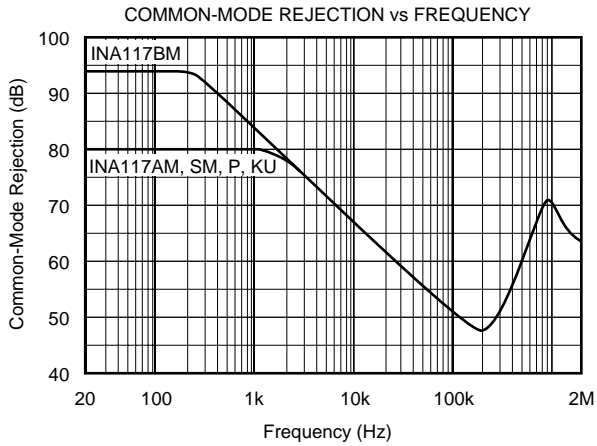

TYPICAL PERFORMANCE CURVES (Cont.)

At $T_A = +25^\circ\text{C}$, $V_S = \pm 15\text{V}$, unless otherwise noted.

SMALL SIGNAL STEP RESPONSE
 $C_L = 0$

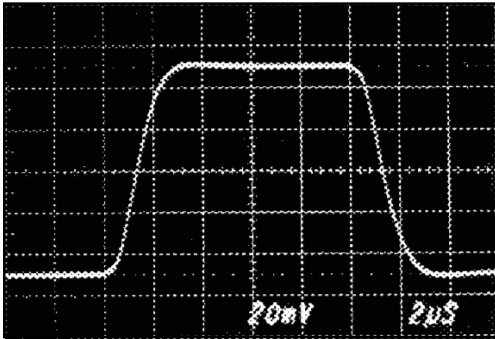

SMALL SIGNAL STEP RESPONSE
 $C_L = 1000\text{pF}$

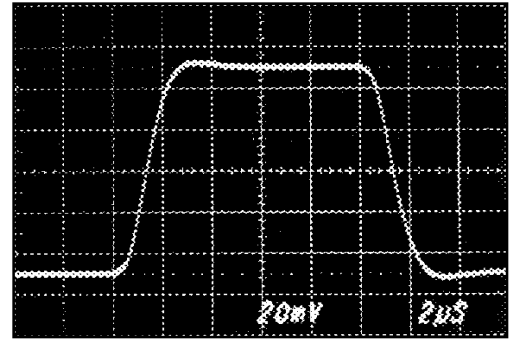

LARGE SIGNAL STEP RESPONSE

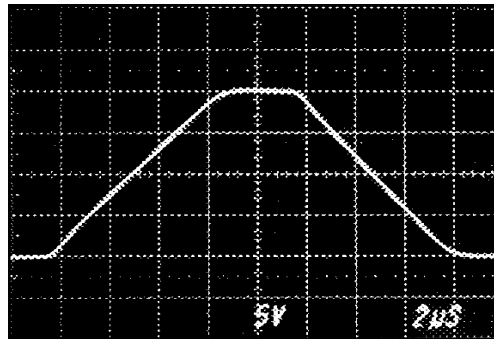

APPLICATION INFORMATION

Figure 1 shows the basic connections required for operation.

Applications with noisy or high-impedance power-supply lines may require decoupling capacitors close to the device pins.

The output voltage is equal to the differential input voltage between pins 2 and 3. The common mode input voltage is rejected.

Internal circuitry connected to the compensation pin 8 cancels the parasitic distributed capacitance between the feedback resistor, R_2 , and the IC substrate. For specified dynamic performance, pin 8 should be grounded or connected through a $0.1\mu\text{F}$ capacitor to an AC ground such as V_+ .

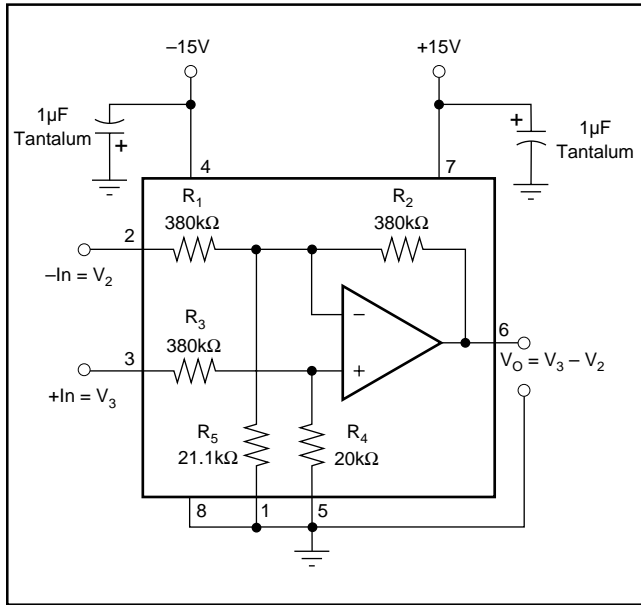

FIGURE 1. Basic Power and Signal Connections.

COMMON-MODE REJECTION

Common-mode rejection (CMR) of the INA117 is dependent on the input resistor network, which is laser-trimmed for accurate ratio matching. To maintain high CMR, it is important to have low source impedances driving the two inputs. A 75Ω resistance in series with pin 2 or 3 will decrease CMR from 86dB to 72dB.

Resistance in series with the reference pins will also degrade CMR. A 4Ω resistance in series with pin 1 or 5 will decrease CMRR from 86dB to 72dB.

Most applications do not require trimming. Figures 2 and 3 show optional circuits that may be used for trimming offset voltage and common-mode rejection.

TRANSFER FUNCTION

Most applications use the INA117 as a simple unity-gain difference amplifier. The transfer function is:

$$V_O = V_3 - V_2$$

V_3 and V_2 are the voltages at pins 3 and 2.

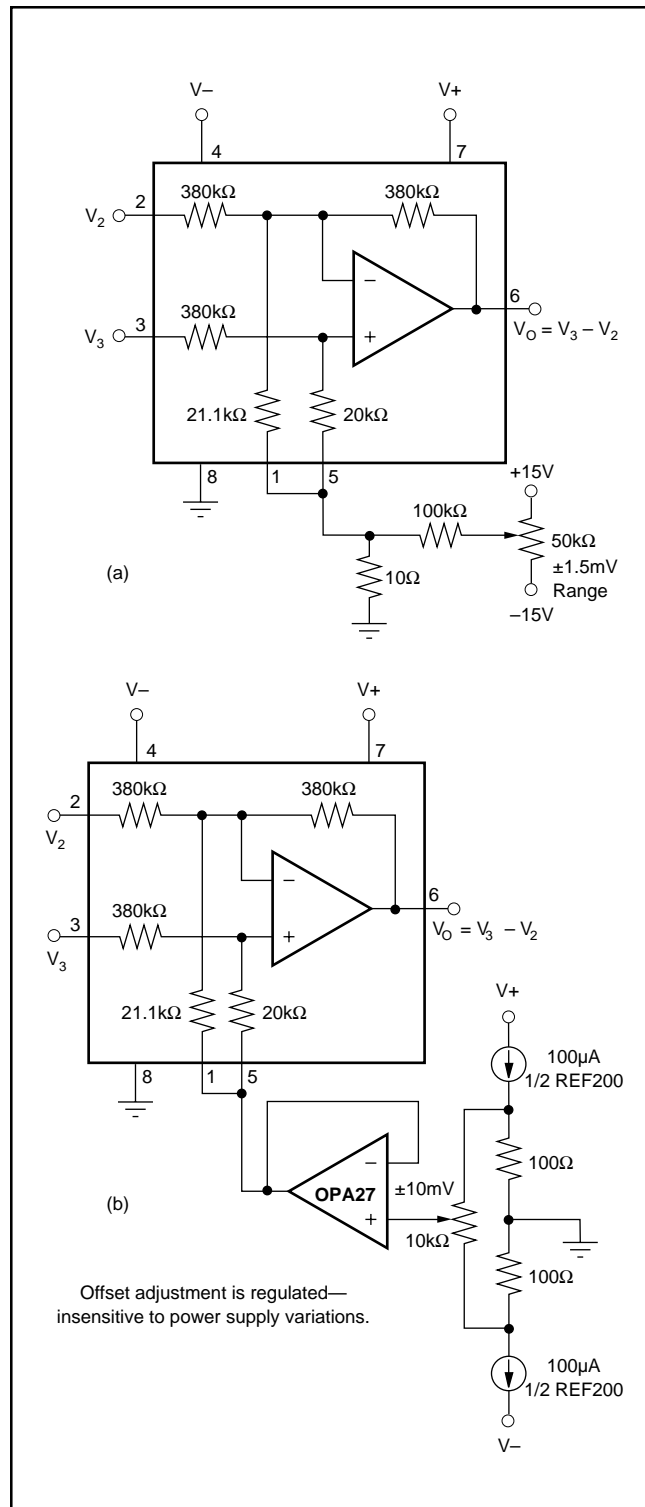

FIGURE 2. Offset Voltage Trim Circuits.

Some applications, however, apply voltages to the reference terminals (pins 1 and 5). A more complete transfer function is:

$$V_O = V_3 - V_2 + 19 \cdot V_5 - 18 \cdot V_1$$

V_5 and V_1 are the voltages at pins 5 and 1.

MEASURING CURRENT

The INA117 can be used to measure a current by sensing the voltage drop across a series resistor, R_S . Figure 4 shows the INA117 used to measure the supply currents of a device under test. The circuit in Figure 5 measures the output current of a power supply. If the power supply has a sense connection, it can be connected to the output side of R_S to eliminate the voltage-drop error. Another common application is current-to-voltage conversion, as shown in Figure 6.

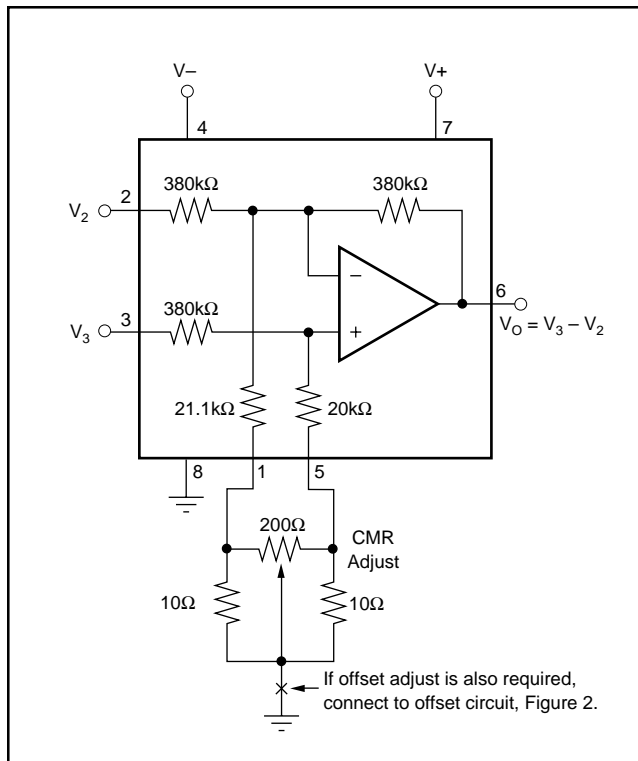

FIGURE 3. CMR Trim Circuit.

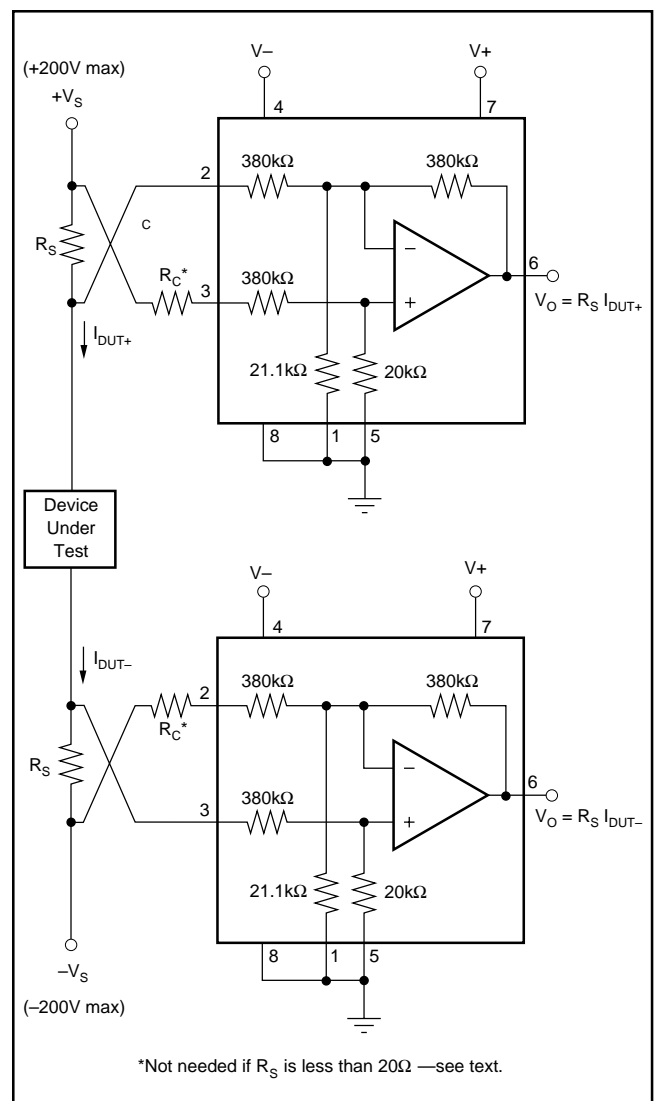

FIGURE 4. Measuring Supply Currents of Device Under Test.

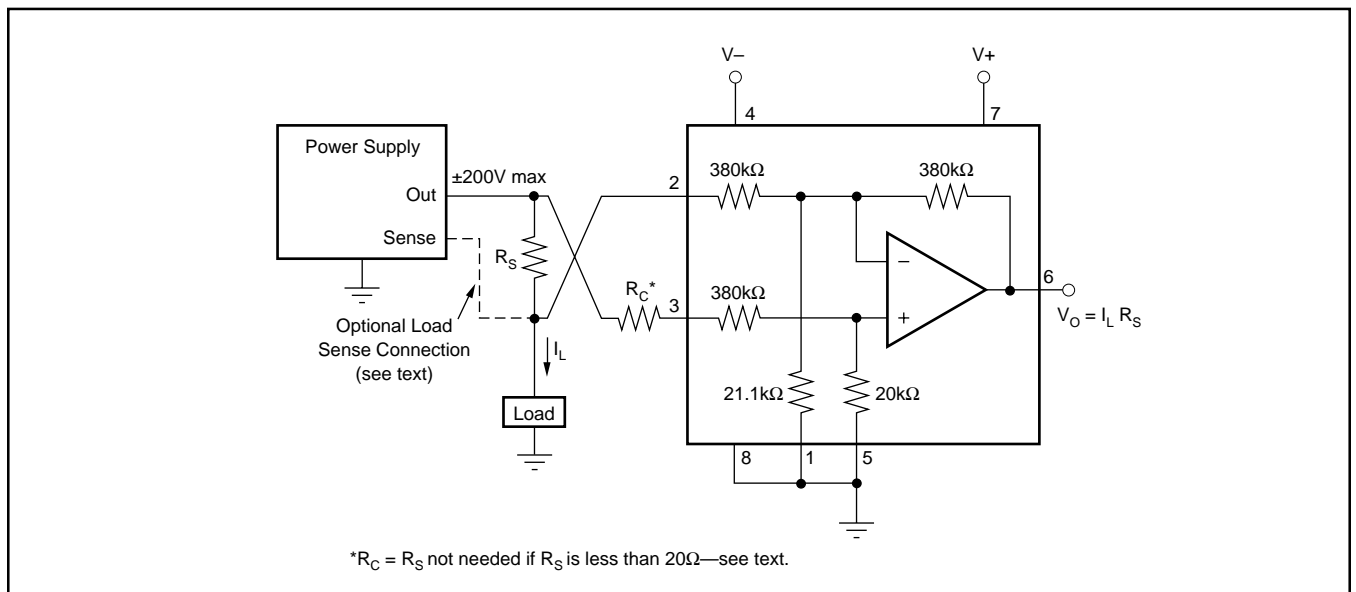

FIGURE 5. Measuring Power Supply Output Current.

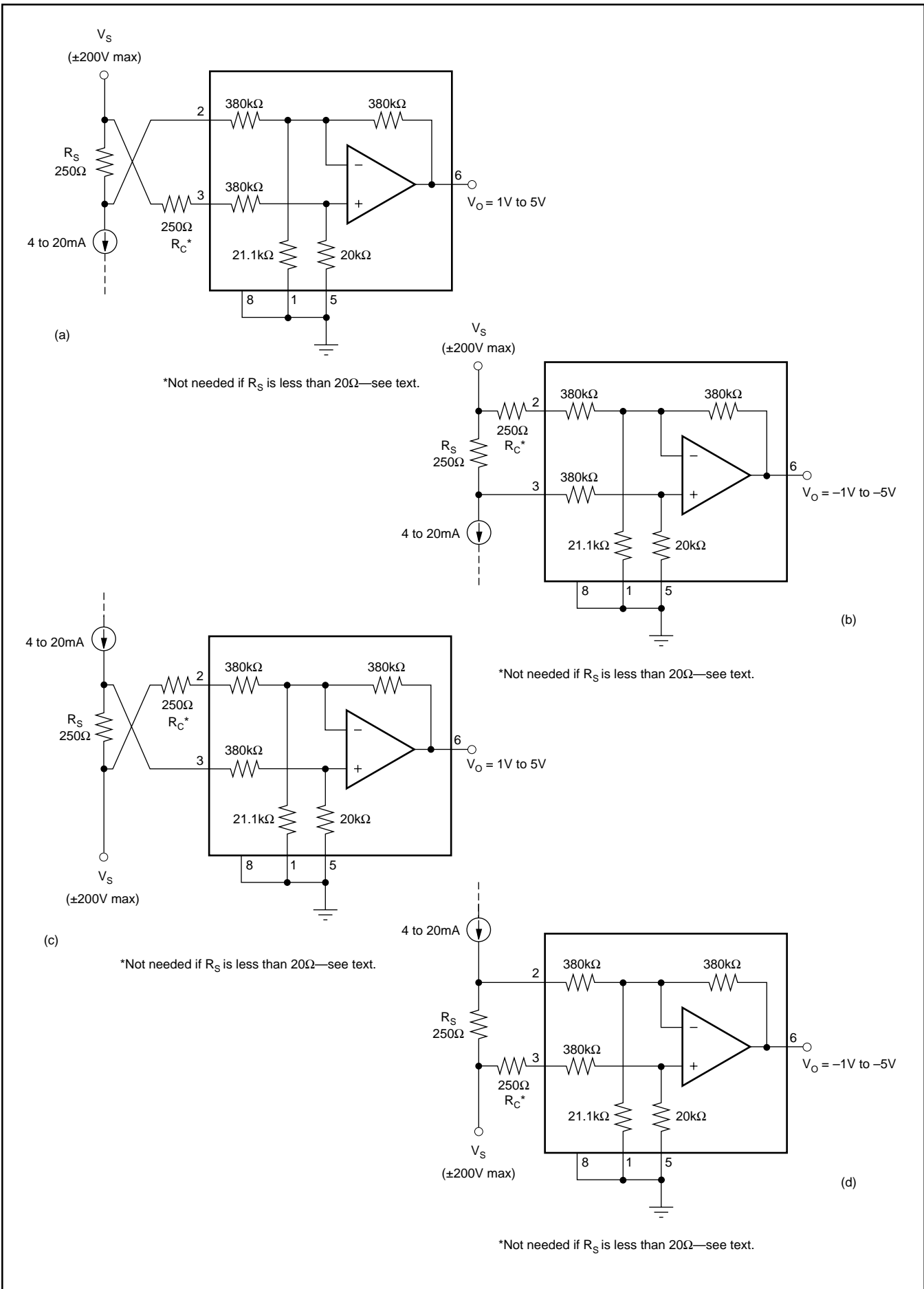

FIGURE 6. Current to Voltage Converter.

In all cases, the sense resistor imbalances the input resistor matching of the INA117, degrading its CMR. Also, the input impedance of the INA117 loads R_S , causing gain error in the voltage-to-current conversion. Both of these errors can be easily corrected.

The CMR error can be corrected with the addition of a compensation resistor, R_C , equal in value to R_S as shown in Figures 4, 5, and 6. If R_S is less than 20Ω , the degradation in CMR is negligible and R_C can be omitted. If R_S is larger than approximately $2k\Omega$, trimming R_C may be required to achieve greater than 86dB CMR. This is because the actual INA117 input impedances have 1% typical mismatch.

If R_S is more than approximately 100Ω , the gain error will be greater than the 0.02% specification of the INA117. This gain error can be corrected by slightly increasing the value of R_S . The corrected value, R_S' , can be calculated by:

$$R_S' = \frac{R_S \cdot 380k\Omega}{380k\Omega - R_S}$$

Example: For a 1V/mA transfer function, the nominal, uncorrected value for R_S would be $1k\Omega$. A slightly larger value, $R_S' = 1002.6\Omega$, compensates for the gain error due to loading.

The $380k\Omega$ term in the equation for R_S' has a tolerance of $\pm 25\%$, so sense resistors above approximately 400Ω may require trimming to achieve gain accuracy better than 0.02%.

Of course, if a buffer amplifier is added as shown in Figure 7, both inputs see a low source impedance, and the sense resistor is not loaded. As a result, there is no gain error or CMR degradation. The buffer amplifier can operate as a unity gain buffer or as an amplifier with non-inverting gain. Gain added ahead of the INA117 improves both CMR and signal-to-noise. Added gain also allows a lower voltage drop across the sense resistor. The OPA1013 is a good choice for the buffer amplifier since both its input and output can swing close to its negative power supply.

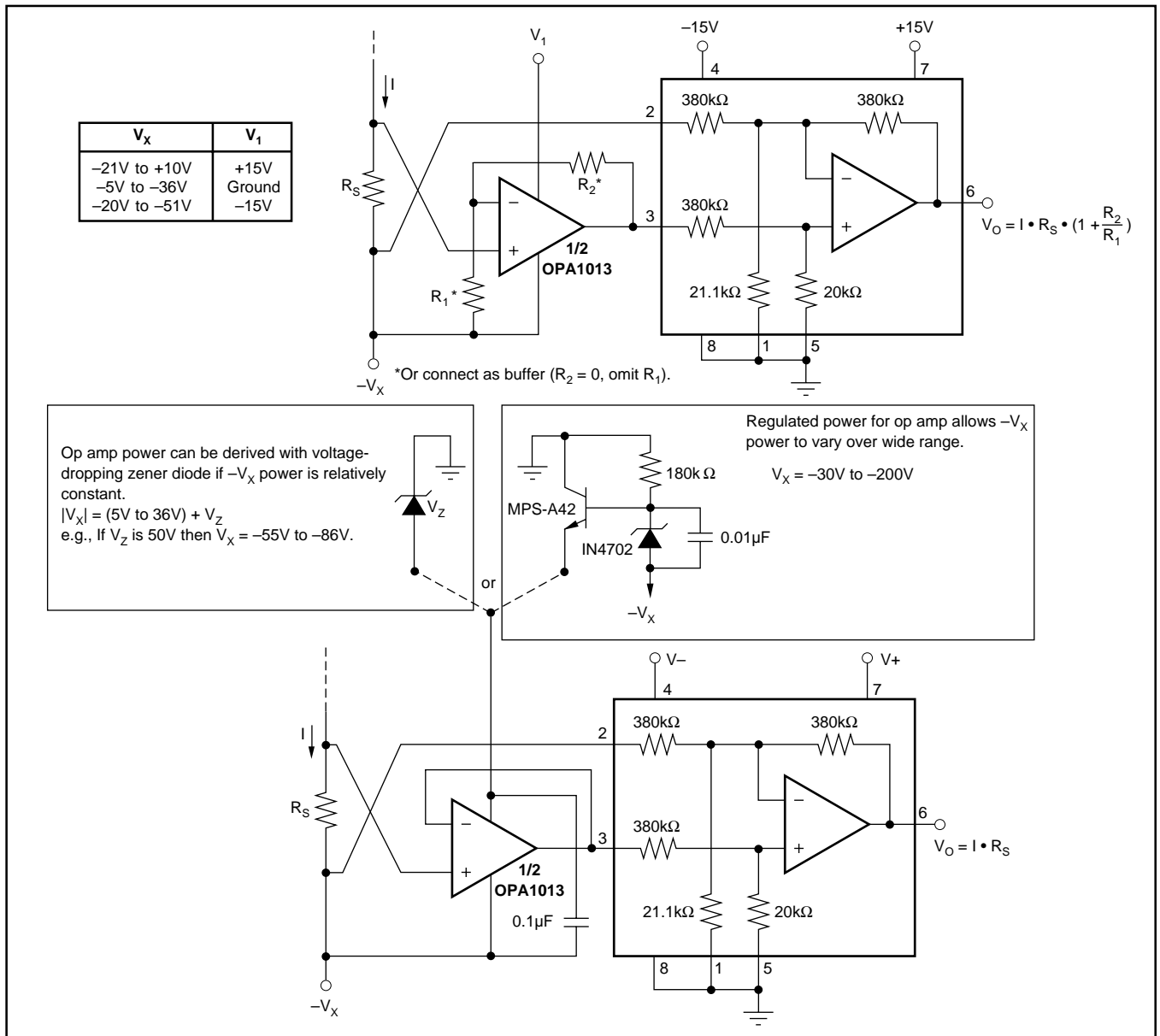

FIGURE 7. Current Sensing with Input Buffer.

Figure 8 shows very high input impedance buffer used to measure low leakage currents. Here, the buffer op amp is powered with an isolated, split-voltage power supply. Using an isolated power supply allows full $\pm 200\text{V}$ common-mode input range.

NOISE PERFORMANCE

The noise performance of the INA117 is dominated by the internal resistor network. The thermal or Johnson noise of

these resistors produces approximately $550\text{nV}/\sqrt{\text{Hz}}$ noise. The internal op amp contributes virtually no excess noise at frequencies above 100Hz.

Many applications may be satisfied with less than the full 200kHz bandwidth of the INA117. In these cases, the noise can be reduced with a low-pass filter on the output. The two-pole filter shown in Figure 9 limits bandwidth to 1kHz and reduces noise by more than 15:1. Since the INA117 has a $1/f$ noise corner frequency of approximately 100Hz, a cutoff frequency below 100Hz will not further reduce noise.

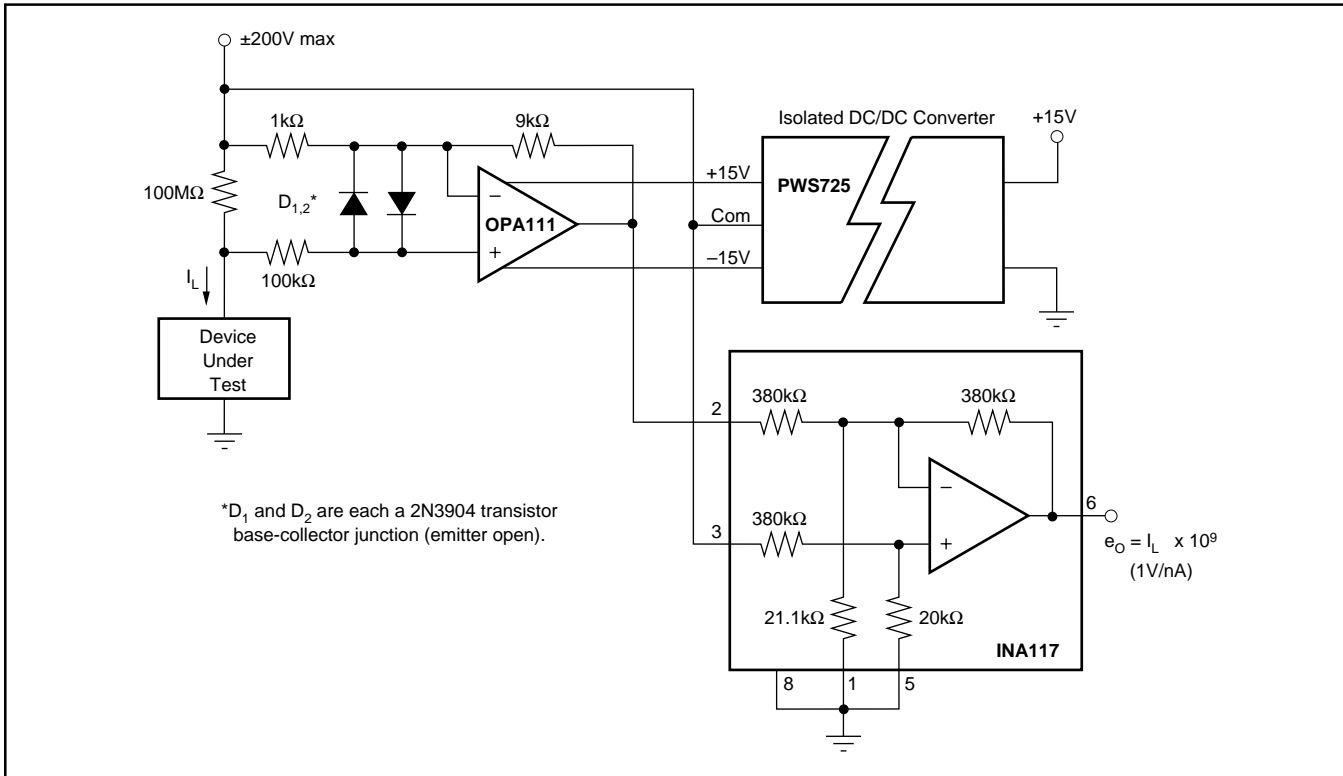

FIGURE 8. Leakage Current Measurement Circuit.

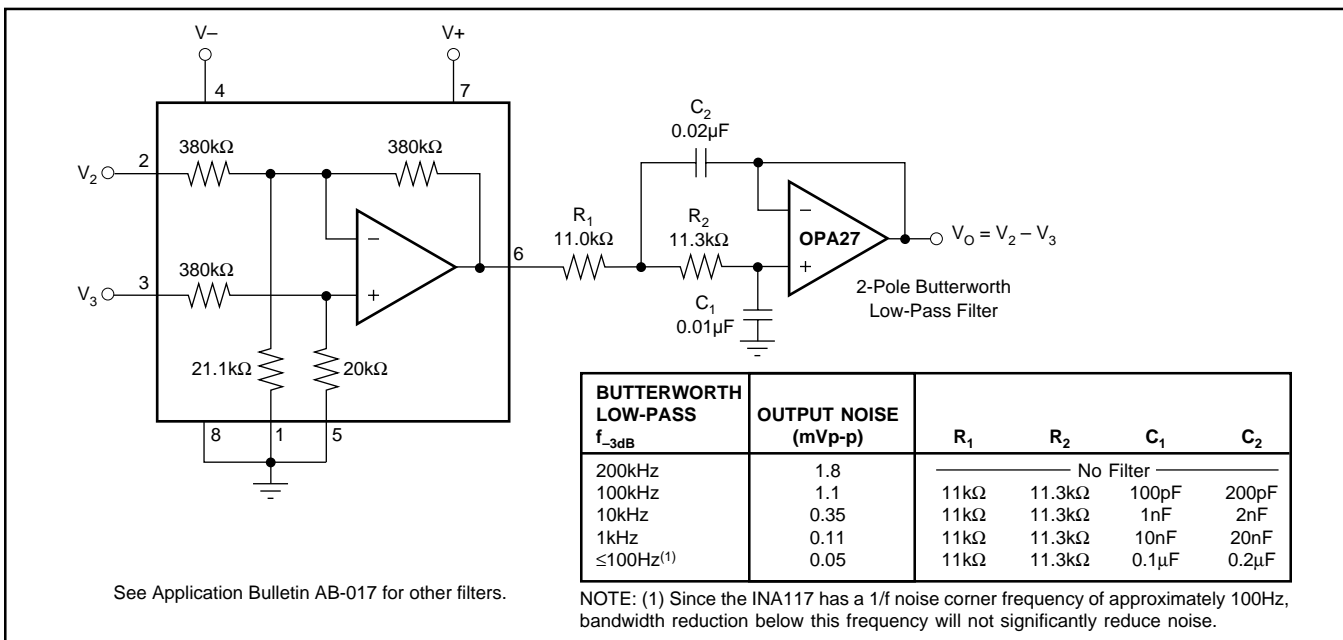

FIGURE 9. Output Filter for Noise Reduction.

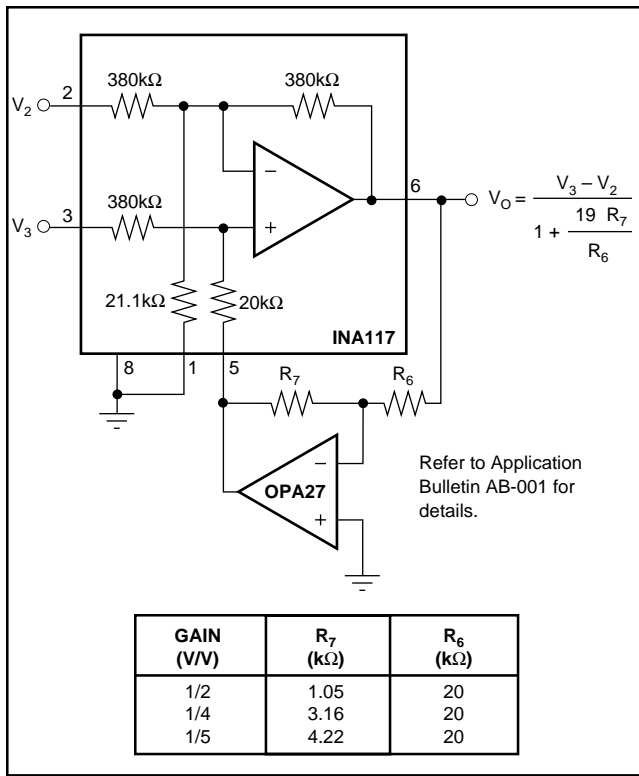

FIGURE 10. Reducing Differential Gain.

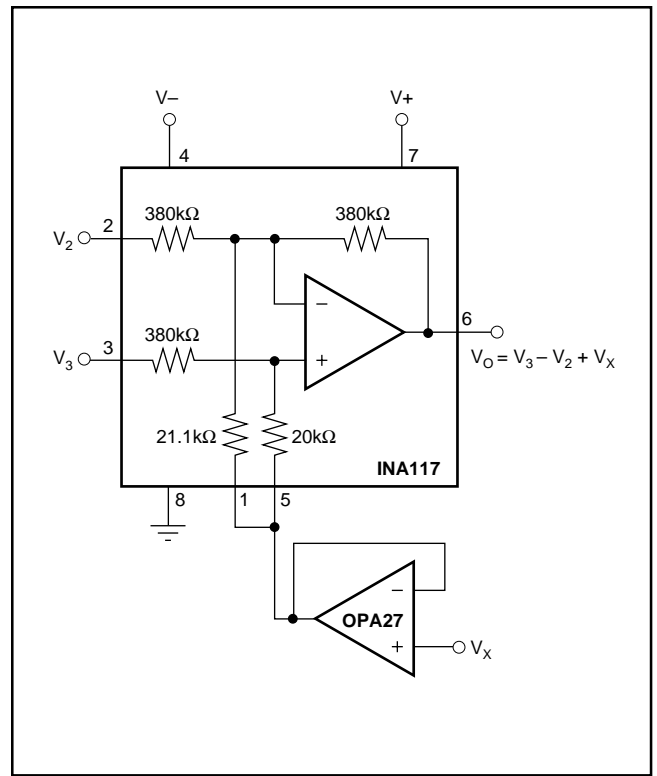

FIGURE 11. Summing V_X in Output.

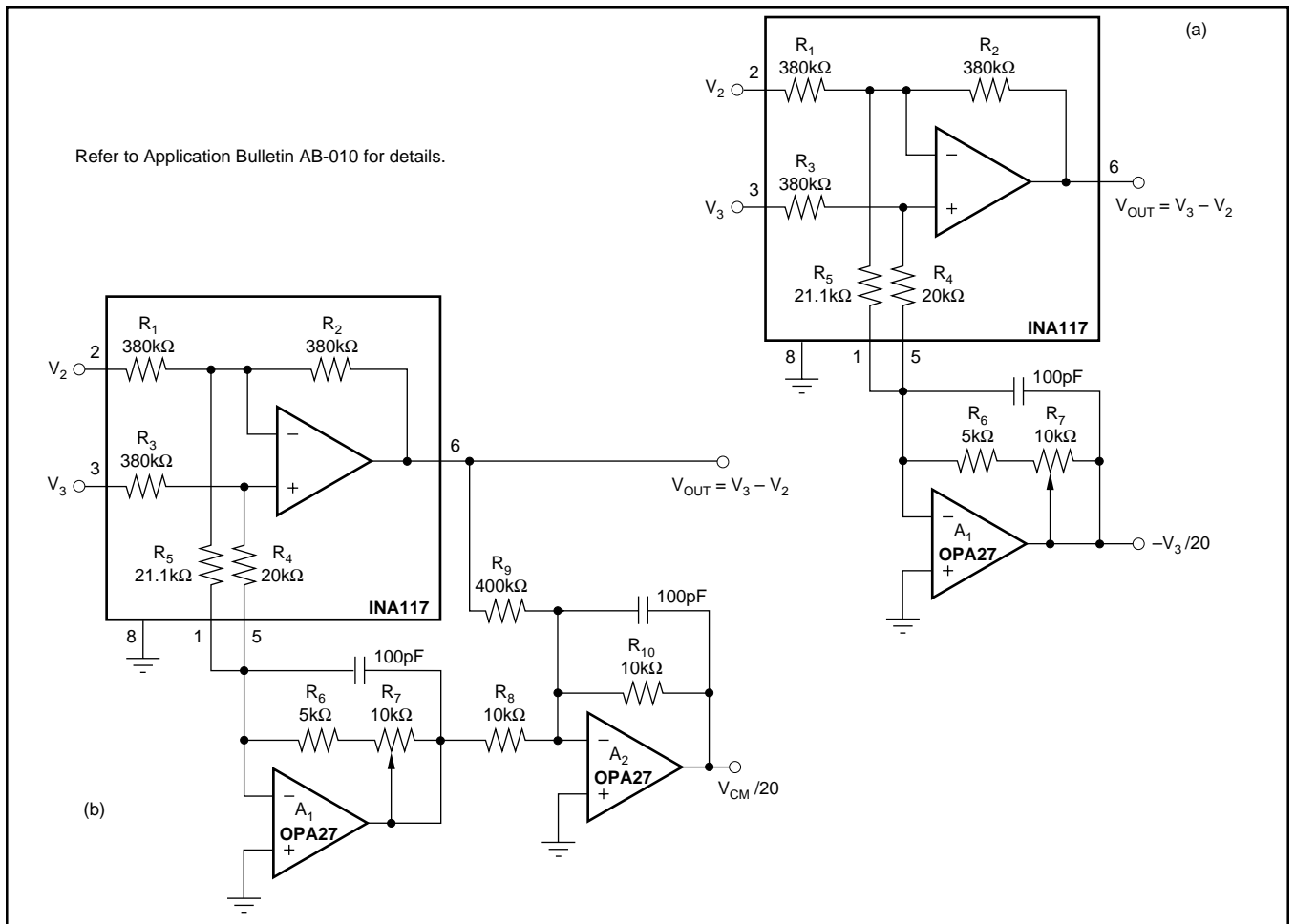

FIGURE 12. Common-Mode Voltage Monitoring.

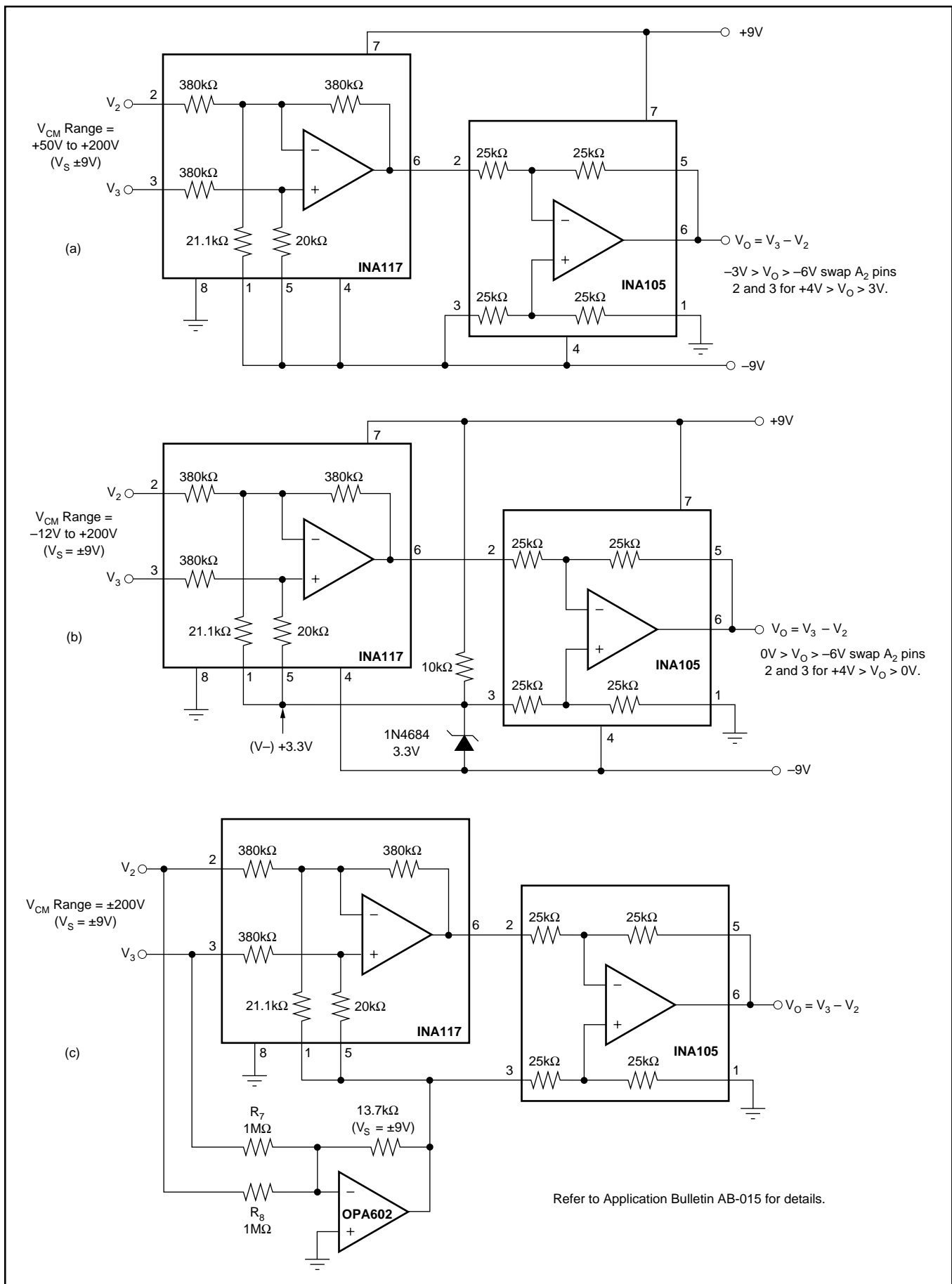

FIGURE 13. Offsetting or Boosting Common-Mode Voltage Range for Reduced Power-Supply Voltage Operation.

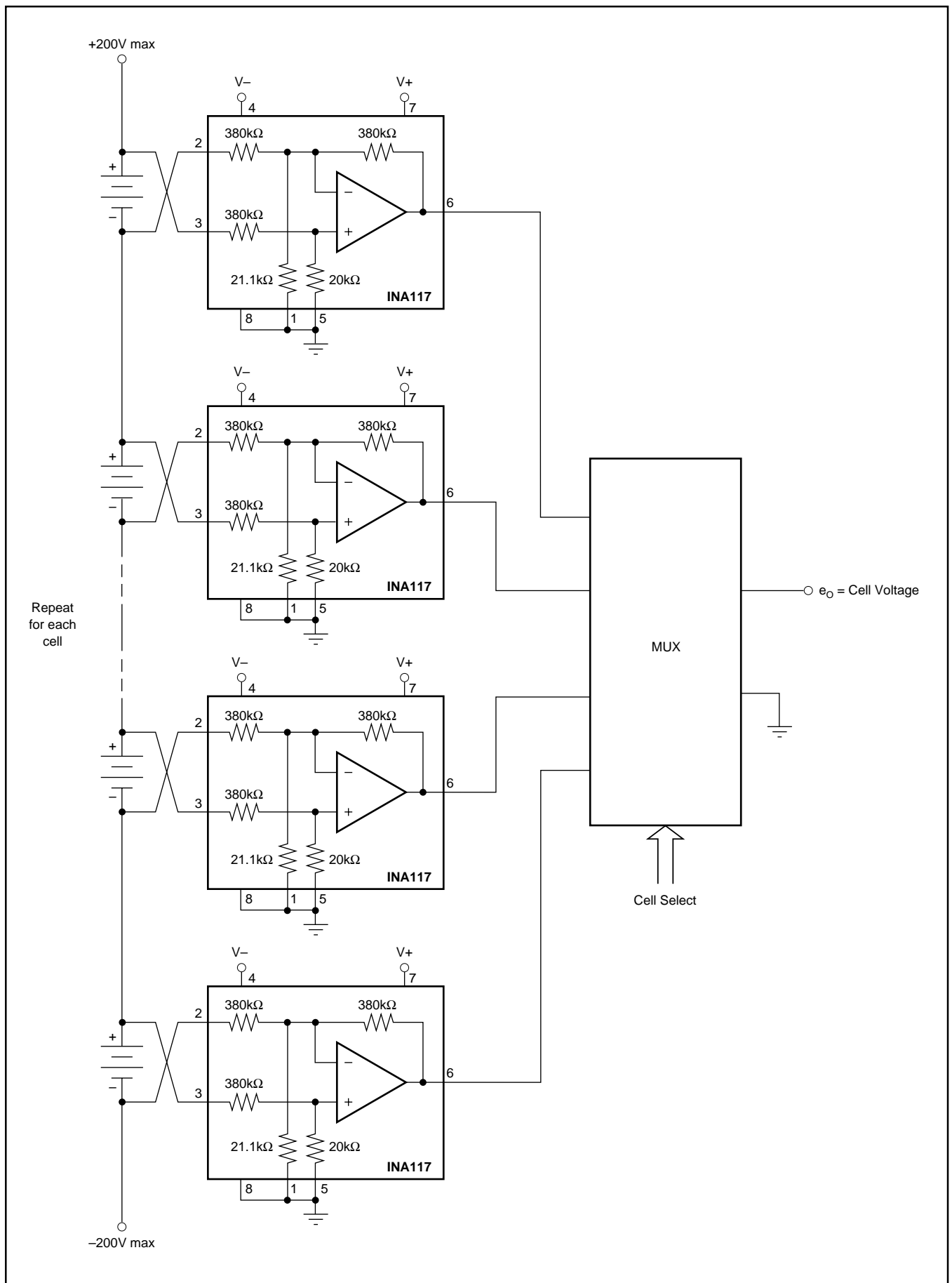

FIGURE 14. Battery Cell Voltage Monitor.

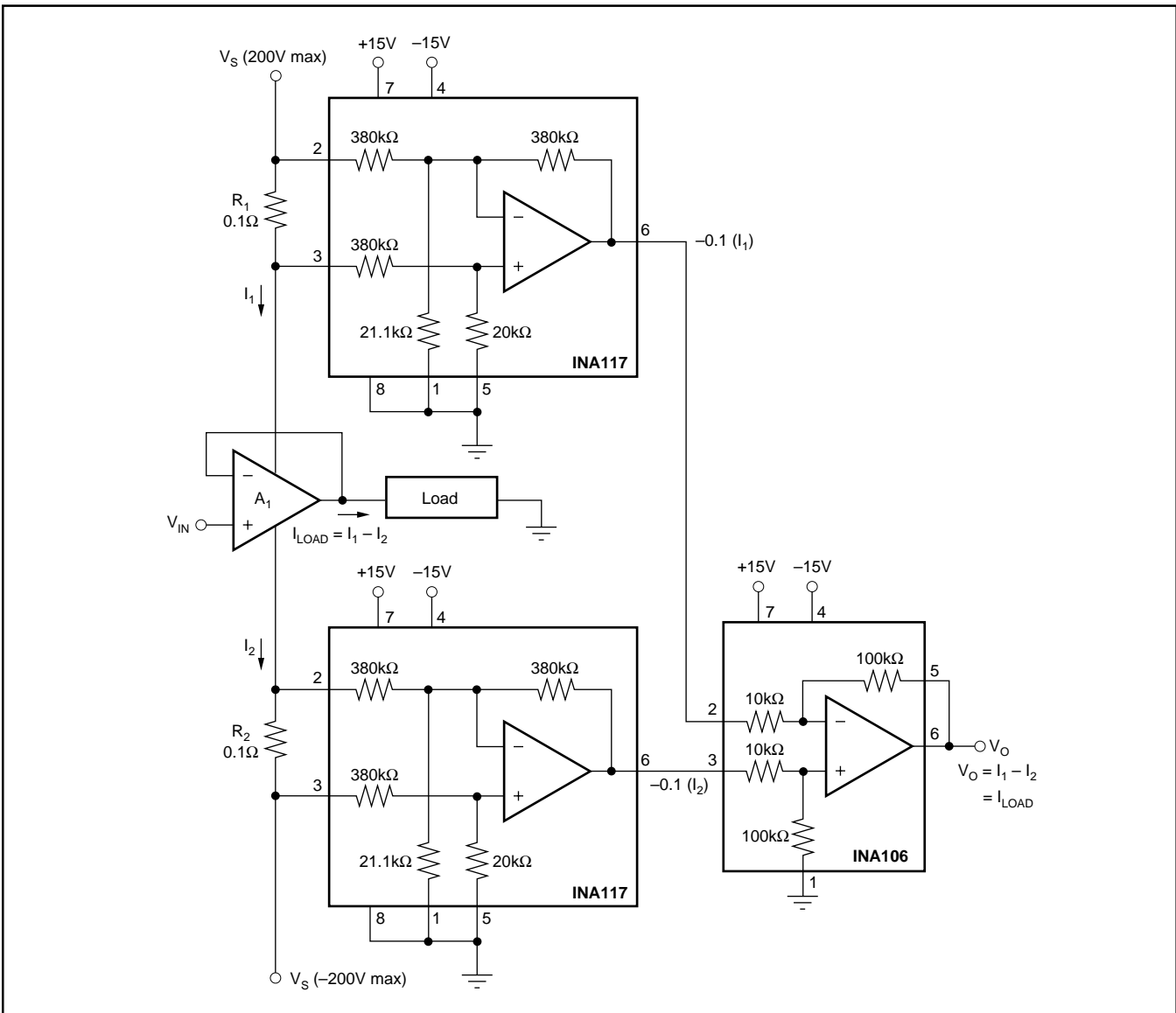

FIGURE 15. Measuring Amplifier Load Current.

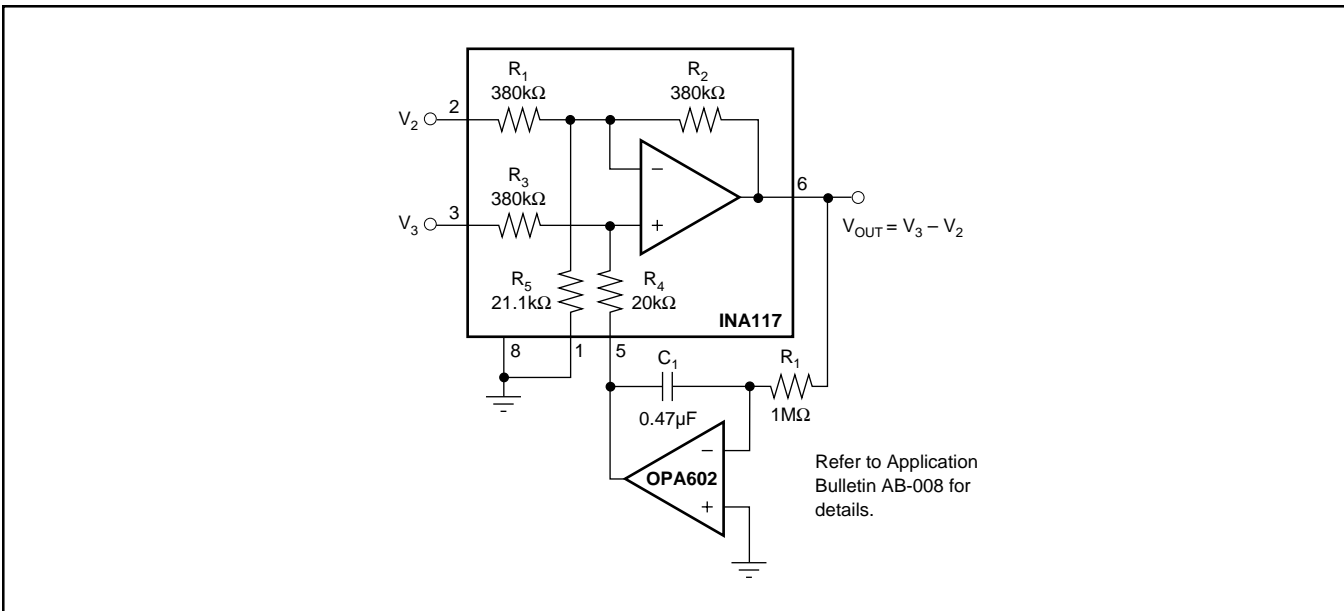

FIGURE 16. AC-Coupled INA117.

PACKAGING INFORMATION

Orderable Device	Status ⁽¹⁾	Package Type	Package Drawing	Pins	Package Qty	Eco Plan ⁽²⁾	Lead/ Ball Finish	MSL Peak Temp ⁽³⁾	Samples (Requires Login)
INA117AM	NRND	TO-99	LMC	8	20	Green (RoHS & no Sb/Br)	AU	N / A for Pkg Type	
INA117AM4	OBSOLETE	TO-100	LME	10		TBD	Call TI	Call TI	
INA117BM	NRND	TO-99	LMC	8	20	Green (RoHS & no Sb/Br)	AU	N / A for Pkg Type	
INA117BM-22	OBSOLETE	TO-100	LME	10		TBD	Call TI	Call TI	
INA117BM-3	OBSOLETE	ZZ (BB)	ZZ001	8		TBD	Call TI	Call TI	
INA117BM-33	OBSOLETE	TO-100	LME	10		TBD	Call TI	Call TI	
INA117BM1	OBSOLETE	TO-100	LME	10		TBD	Call TI	Call TI	
INA117KU	ACTIVE	SOIC	D	8	75	Green (RoHS & no Sb/Br)	CU NIPDAU	Level-3-260C-168 HR	
INA117KU/2K5	ACTIVE	SOIC	D	8	2500	Green (RoHS & no Sb/Br)	CU NIPDAU	Level-3-260C-168 HR	
INA117KU/2K5G4	ACTIVE	SOIC	D	8	2500	Green (RoHS & no Sb/Br)	CU NIPDAU	Level-3-260C-168 HR	
INA117KUG4	ACTIVE	SOIC	D	8	75	Green (RoHS & no Sb/Br)	CU NIPDAU	Level-3-260C-168 HR	
INA117P	ACTIVE	PDIP	P	8	50	Green (RoHS & no Sb/Br)	CU NIPDAU	N / A for Pkg Type	
INA117P-BI	OBSOLETE	PDIP	P	8		TBD	Call TI	Call TI	
INA117PG4	ACTIVE	PDIP	P	8	50	Green (RoHS & no Sb/Br)	CU NIPDAU	N / A for Pkg Type	
INA117SM	NRND	TO-99	LMC	8	20	Green (RoHS & no Sb/Br)	AU	N / A for Pkg Type	
INA117SMQ	NRND	TO-99	LMC	8	20	Green (RoHS & no Sb/Br)	AU	N / A for Pkg Type	

⁽¹⁾ The marketing status values are defined as follows:

ACTIVE: Product device recommended for new designs.

LIFEBUY: TI has announced that the device will be discontinued, and a lifetime-buy period is in effect.

NRND: Not recommended for new designs. Device is in production to support existing customers, but TI does not recommend using this part in a new design.

PREVIEW: Device has been announced but is not in production. Samples may or may not be available.

OBSOLETE: TI has discontinued the production of the device.

⁽²⁾ Eco Plan - The planned eco-friendly classification: Pb-Free (RoHS), Pb-Free (RoHS Exempt), or Green (RoHS & no Sb/Br) - please check <http://www.ti.com/productcontent> for the latest availability information and additional product content details.

TBD: The Pb-Free/Green conversion plan has not been defined.

Pb-Free (RoHS): TI's terms "Lead-Free" or "Pb-Free" mean semiconductor products that are compatible with the current RoHS requirements for all 6 substances, including the requirement that lead not exceed 0.1% by weight in homogeneous materials. Where designed to be soldered at high temperatures, TI Pb-Free products are suitable for use in specified lead-free processes.

Pb-Free (RoHS Exempt): This component has a RoHS exemption for either 1) lead-based flip-chip solder bumps used between the die and package, or 2) lead-based die adhesive used between the die and leadframe. The component is otherwise considered Pb-Free (RoHS compatible) as defined above.

Green (RoHS & no Sb/Br): TI defines "Green" to mean Pb-Free (RoHS compatible), and free of Bromine (Br) and Antimony (Sb) based flame retardants (Br or Sb do not exceed 0.1% by weight in homogeneous material)

⁽³⁾ MSL, Peak Temp. -- The Moisture Sensitivity Level rating according to the JEDEC industry standard classifications, and peak solder temperature.

Important Information and Disclaimer: The information provided on this page represents TI's knowledge and belief as of the date that it is provided. TI bases its knowledge and belief on information provided by third parties, and makes no representation or warranty as to the accuracy of such information. Efforts are underway to better integrate information from third parties. TI has taken and continues to take reasonable steps to provide representative and accurate information but may not have conducted destructive testing or chemical analysis on incoming materials and chemicals. TI and TI suppliers consider certain information to be proprietary, and thus CAS numbers and other limited information may not be available for release.

In no event shall TI's liability arising out of such information exceed the total purchase price of the TI part(s) at issue in this document sold by TI to Customer on an annual basis.

TAPE AND REEL INFORMATION

REEL DIMENSIONS

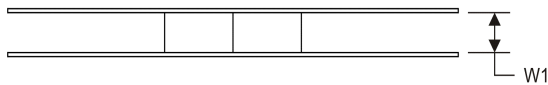
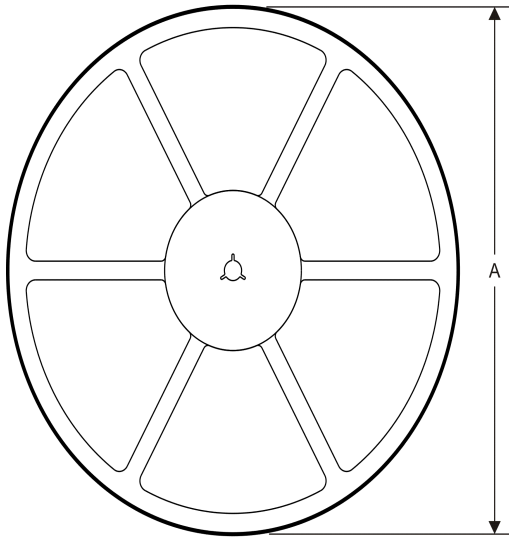

TAPE DIMENSIONS

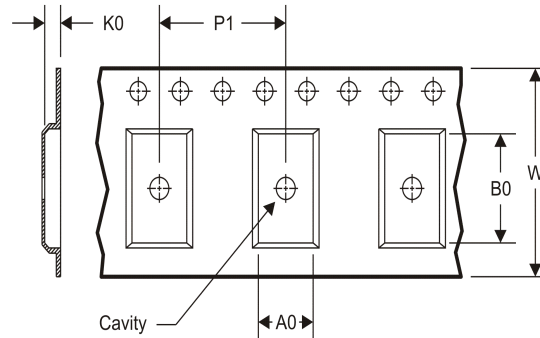

A0	Dimension designed to accommodate the component width
B0	Dimension designed to accommodate the component length
K0	Dimension designed to accommodate the component thickness
W	Overall width of the carrier tape
P1	Pitch between successive cavity centers

TAPE AND REEL INFORMATION

*All dimensions are nominal

Device	Package Type	Package Drawing	Pins	SPQ	Reel Diameter (mm)	Reel Width W1 (mm)	A0 (mm)	B0 (mm)	K0 (mm)	P1 (mm)	W (mm)	Pin1 Quadrant
INA117KU/2K5	SOIC	D	8	2500	330.0	12.4	6.4	5.2	2.1	8.0	12.0	Q1

TAPE AND REEL BOX DIMENSIONS



*All dimensions are nominal

Device	Package Type	Package Drawing	Pins	SPQ	Length (mm)	Width (mm)	Height (mm)
INA117KU/2K5	SOIC	D	8	2500	367.0	367.0	35.0

IMPORTANT NOTICE

Texas Instruments Incorporated and its subsidiaries (TI) reserve the right to make corrections, enhancements, improvements and other changes to its semiconductor products and services per JESD46C and to discontinue any product or service per JESD48B. Buyers should obtain the latest relevant information before placing orders and should verify that such information is current and complete. All semiconductor products (also referred to herein as "components") are sold subject to TI's terms and conditions of sale supplied at the time of order acknowledgment.

TI warrants performance of its components to the specifications applicable at the time of sale, in accordance with the warranty in TI's terms and conditions of sale of semiconductor products. Testing and other quality control techniques are used to the extent TI deems necessary to support this warranty. Except where mandated by applicable law, testing of all parameters of each component is not necessarily performed.

TI assumes no liability for applications assistance or the design of Buyers' products. Buyers are responsible for their products and applications using TI components. To minimize the risks associated with Buyers' products and applications, Buyers should provide adequate design and operating safeguards.

TI does not warrant or represent that any license, either express or implied, is granted under any patent right, copyright, mask work right, or other intellectual property right relating to any combination, machine, or process in which TI components or services are used. Information published by TI regarding third-party products or services does not constitute a license to use such products or services or a warranty or endorsement thereof. Use of such information may require a license from a third party under the patents or other intellectual property of the third party, or a license from TI under the patents or other intellectual property of TI.

Reproduction of significant portions of TI information in TI data books or data sheets is permissible only if reproduction is without alteration and is accompanied by all associated warranties, conditions, limitations, and notices. TI is not responsible or liable for such altered documentation. Information of third parties may be subject to additional restrictions.

Resale of TI components or services with statements different from or beyond the parameters stated by TI for that component or service voids all express and any implied warranties for the associated TI component or service and is an unfair and deceptive business practice. TI is not responsible or liable for any such statements.

Buyer acknowledges and agrees that it is solely responsible for compliance with all legal, regulatory and safety-related requirements concerning its products, and any use of TI components in its applications, notwithstanding any applications-related information or support that may be provided by TI. Buyer represents and agrees that it has all the necessary expertise to create and implement safeguards which anticipate dangerous consequences of failures, monitor failures and their consequences, lessen the likelihood of failures that might cause harm and take appropriate remedial actions. Buyer will fully indemnify TI and its representatives against any damages arising out of the use of any TI components in safety-critical applications.

In some cases, TI components may be promoted specifically to facilitate safety-related applications. With such components, TI's goal is to help enable customers to design and create their own end-product solutions that meet applicable functional safety standards and requirements. Nonetheless, such components are subject to these terms.

No TI components are authorized for use in FDA Class III (or similar life-critical medical equipment) unless authorized officers of the parties have executed a special agreement specifically governing such use.

Only those TI components which TI has specifically designated as military grade or "enhanced plastic" are designed and intended for use in military/aerospace applications or environments. Buyer acknowledges and agrees that any military or aerospace use of TI components which have **not** been so designated is solely at the Buyer's risk, and that Buyer is solely responsible for compliance with all legal and regulatory requirements in connection with such use.

TI has specifically designated certain components which meet ISO/TS16949 requirements, mainly for automotive use. Components which have not been so designated are neither designed nor intended for automotive use; and TI will not be responsible for any failure of such components to meet such requirements.

Products

Audio	www.ti.com/audio
Amplifiers	amplifier.ti.com
Data Converters	dataconverter.ti.com
DLP® Products	www.dlp.com
DSP	dsp.ti.com
Clocks and Timers	www.ti.com/clocks
Interface	interface.ti.com
Logic	logic.ti.com
Power Mgmt	power.ti.com
Microcontrollers	microcontroller.ti.com
RFID	www.ti-rfid.com
OMAP Mobile Processors	www.ti.com/omap
Wireless Connectivity	www.ti.com/wirelessconnectivity

Applications

Automotive and Transportation	www.ti.com/automotive
Communications and Telecom	www.ti.com/communications
Computers and Peripherals	www.ti.com/computers
Consumer Electronics	www.ti.com/consumer-apps
Energy and Lighting	www.ti.com/energy
Industrial	www.ti.com/industrial
Medical	www.ti.com/medical
Security	www.ti.com/security
Space, Avionics and Defense	www.ti.com/space-avionics-defense
Video and Imaging	www.ti.com/video

TI E2E Community e2e.ti.com