

## INCREASING INA117 DIFFERENTIAL INPUT RANGE

By R. Mark Stitt (520) 746-7445

The INA117 is a monolithic difference amplifier with the unique ability to accept up to  $\pm 200V$  common-mode input signals while operating on standard  $\pm 15V$  power supplies. Because the gain of the INA117 is set at  $1V/V$ , and because the output would saturate into the rails at about  $\pm 12V$ , the maximum specified differential input range is  $\pm 10V$ .

Since the common-mode input range is  $\pm 200V$ , it makes sense that some designers would also like to use the part for differential inputs greater than  $\pm 10V$ . Figure 1 shows the recommended circuit. Adding resistors to the input may seem simpler, but there are some problems with that approach.

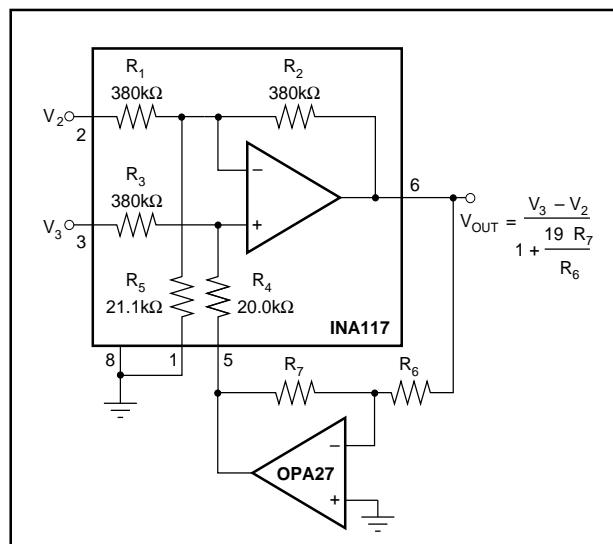

FIGURE 1. INA117 with Increased Differential Input Range.

The performance of the INA117 depends on extremely precise resistor matching (0.005% for 86dB CMR). Resistors added to the input must be adjusted to at least this accuracy to maintain high performance. Both gain error and CMR must be adjusted. Maintaining 86dB CMR over temperature requires  $1\text{ppm}/^\circ\text{C}$  resistor TCR tracking. Significant resistance added external to the INA117 would require the same performance.

By using the circuit shown in Figure 1, internal resistor matching is preserved, and the INA117 CMR and CMR drift with temperature are maintained. Gain can be set independ-

ently of CMR by adjusting the inverter resistors,  $R_6$ ,  $R_7$ . Gain drift is preserved so long as  $R_6$  and  $R_7$  track with temperature. Furthermore, noise at the output is improved by the gain reduction factor whereas it is unchanged with the other approach.

To understand how the circuit works, consider the INA117 to be a four-input summing amplifier as shown in Figure 2.

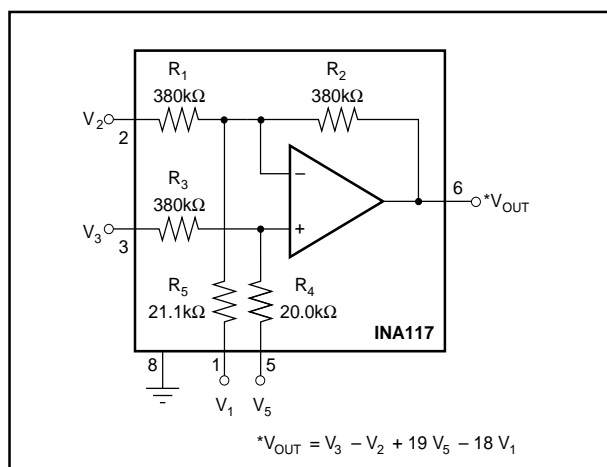

FIGURE 2. INA117 Shown as a Four-Input Summing Amplifier.

CMR is preserved and the gain is reduced if a small portion of the output signal is inverted and fed back to pin 5 with  $V_1$  set to zero ( $V_1$  grounded).

$$\text{Where: } V_{\text{OUT}} = V_3 - V_2 + 19 \cdot V_5 - 18 \cdot V_1$$

If,  $V_5 = -V_{\text{OUT}} \cdot R_7/R_6$ , then

$$V_{\text{OUT}} = \frac{V_3 - V_2}{1 + \frac{19 \cdot R_7}{R_6}}$$

### SELECTED-GAIN EXAMPLES

GAIN <sup>(1)</sup> (V/V)	$R_7$ (kΩ)	$R_6$ (kΩ)
1/2	1.05	20.0
1/4	3.16	20.0
1/5	4.22	20.0

NOTE: (1) INA117 is not stable in Gain < 1/5.

If CMR adjustment is desired, add a  $10\Omega$  fixed resistor and a  $20\Omega$  pot as shown in Figure 3. Adjust CMR by shorting together pins 2 and 3 of the INA117 and driving them with a 500Hz square wave while observing the output on a scope. Using a square wave rather than a sine wave allows the AC signal to settle out so that the DC CMR can be seen. The

CMR trim will change the gain slightly, so trim CMR first, then trim gain with  $R_6$ ,  $R_7$  if desired.

**The INA117 is now available in three standard 8-pin packages: hermetic TO-99, plastic DIP, and the small surface-mount SOIC package.**

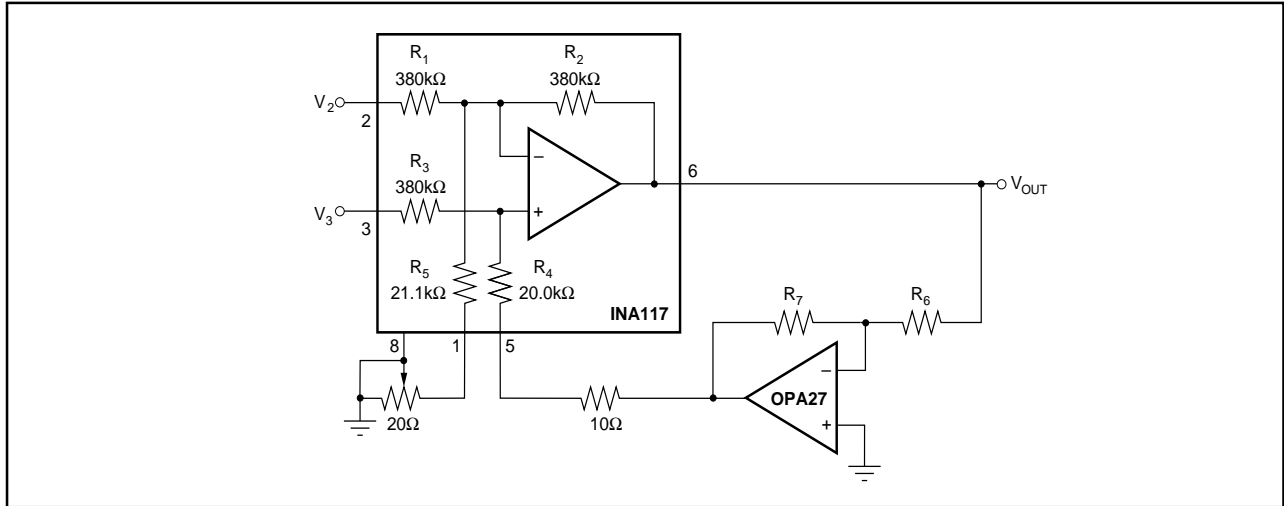

FIGURE 3. INA117 with Increased Differential Input Range with CMR Trim.

The information provided herein is believed to be reliable; however, BURR-BROWN assumes no responsibility for inaccuracies or omissions. BURR-BROWN assumes no responsibility for the use of this information, and all use of such information shall be entirely at the user's own risk. Prices and specifications are subject to change without notice. No patent rights or licenses to any of the circuits described herein are implied or granted to any third party. BURR-BROWN does not authorize or warrant any BURR-BROWN product for use in life support devices and/or systems.

## **IMPORTANT NOTICE**

Texas Instruments and its subsidiaries (TI) reserve the right to make changes to their products or to discontinue any product or service without notice, and advise customers to obtain the latest version of relevant information to verify, before placing orders, that information being relied on is current and complete. All products are sold subject to the terms and conditions of sale supplied at the time of order acknowledgment, including those pertaining to warranty, patent infringement, and limitation of liability.

TI warrants performance of its semiconductor products to the specifications applicable at the time of sale in accordance with TI's standard warranty. Testing and other quality control techniques are utilized to the extent TI deems necessary to support this warranty. Specific testing of all parameters of each device is not necessarily performed, except those mandated by government requirements.

Customers are responsible for their applications using TI components.

In order to minimize risks associated with the customer's applications, adequate design and operating safeguards must be provided by the customer to minimize inherent or procedural hazards.

TI assumes no liability for applications assistance or customer product design. TI does not warrant or represent that any license, either express or implied, is granted under any patent right, copyright, mask work right, or other intellectual property right of TI covering or relating to any combination, machine, or process in which such semiconductor products or services might be or are used. TI's publication of information regarding any third party's products or services does not constitute TI's approval, warranty or endorsement thereof.