

INA101

High Accuracy INSTRUMENTATION AMPLIFIER

FEATURES

- **LOW DRIFT:** 0.25 μ V/ $^{\circ}$ C max
- **LOW OFFSET VOLTAGE:** 25 μ V max
- **LOW NONLINEARITY:** 0.002%
- **LOW NOISE:** 13nV/ $\sqrt{\text{Hz}}$
- **HIGH CMR:** 106dB AT 60Hz
- **HIGH INPUT IMPEDANCE:** 10¹⁰ Ω
- **14-PIN PLASTIC, CERAMIC DIP, SOL-16, AND TO-100 PACKAGES**

APPLICATIONS

- **STRAIN GAGES**
- **THERMOCOUPLES**
- **RTDs**
- **REMOTE TRANSDUCERS**
- **LOW-LEVEL SIGNALS**
- **MEDICAL INSTRUMENTATION**

DESCRIPTION

The INA101 is a high accuracy instrumentation amplifier designed for low-level signal amplification and general purpose data acquisition. Three precision op amps and laser-trimmed metal film resistors are integrated on a single monolithic integrated circuit.

The INA101 is packaged in TO-100 metal, 14-pin plastic and ceramic DIP, and SOL-16 surface-mount packages. Commercial, industrial and military temperature range models are available.

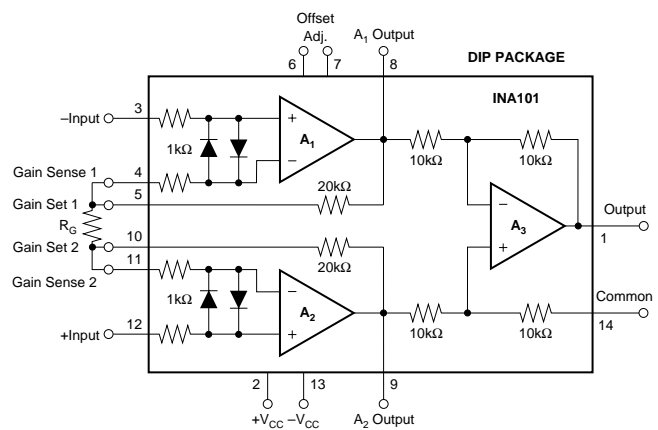
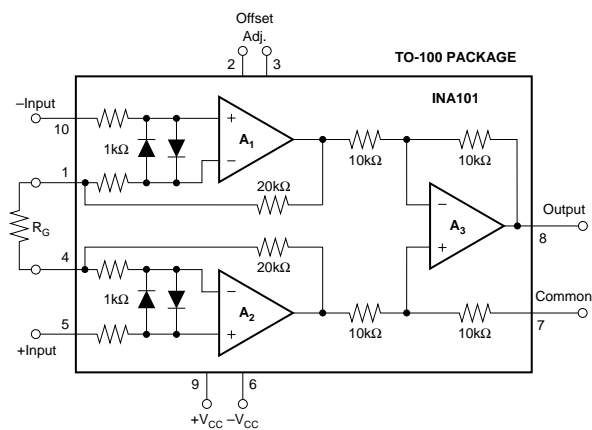

SPECIFICATIONS

ELECTRICAL

At +25°C with ±15VDC power supply and in circuit of Figure 1, unless otherwise noted.

PARAMETER	INA101AM, AG			INA101SM, SG			INA101CM, CG			INA101HP, KU			UNITS
	MIN	TYP	MAX	MIN	TYP	MAX	MIN	TYP	MAX	MIN	TYP	MAX	
GAIN	1			*			*			*			V/V
Range of Gain			1000	*	*	*	*	*	*	*	*	*	V/V
Gain Equation		$G = 1 + (40k/R_G)$			*	*	*	*	*	*	*	*	%
Error from Equation, DC ⁽¹⁾		$\pm(0.04 + 0.00016G - 0.02/G)$	$\pm(0.1 + 0.0003G - 0.05/G)$		*	*	*	*	*	$\pm(0.1 + 0.00015G - 0.05/G)$	$\pm(0.3 + 0.0002G - 0.10/G)$	*	
Gain Temp. Coefficient ⁽³⁾					*	*	*	*	*	*	*	*	ppm/°C
G = 1		2	5		*	*	*	*	*	*	*	*	ppm/°C
G = 10		20	100		*	*	*	*	*	*	*	*	ppm/°C
G = 100		22	110		*	*	*	*	*	*	*	*	ppm/°C
G = 1000		22	110		*	*	*	*	*	*	*	*	ppm/°C
Nonlinearity, DC ⁽²⁾		$\pm(0.002 + 10^{-5} G)$	$\pm(0.005 + 2 \times 10^{-5} G)$		$\pm(0.001 + 10^{-5} G)$	$\pm(0.002 + 10^{-5} G)$		$\pm(0.001 + 10^{-5} G)$	$\pm(0.002 + 10^{-5} G)$		*	*	% of p-p FS
RATED OUTPUT													V
Voltage	±10	±12.5		*	*	*	*	*	*	*	*	*	V
Current	±5	±10		*	*	*	*	*	*	*	*	*	mA
Output Impedance		0.2			*	*		*	*		*	*	Ω
Capacitive Load		1000			*	*		*	*		*	*	pF
INPUT OFFSET VOLTAGE													μV
Initial Offset at +25°C		±(25 + 200/G)	±(50 + 400/G)		±10 + 100/G	±(25 + 200/G)		±(10 + 100/G)	±(25 + 200/G)		±(125 + 450/G)	±(250 + 900/G)	μV
vs Temperature			±(2 + 20/G)			±(0.75 + 10/G)			±(0.25 + 10/G)		±(2 + 20/G)		μV/°C
vs Supply		±(1 + 20/G)			*	*		*	*		*	*	μV/V
vs Time		±(1 + 20/G)			*	*		*	*		*	*	μV/mo
INPUT BIAS CURRENT													nA
Initial Bias Current (each input)		±15	±30		±10	*		±5	±20		*	*	nA
vs Temperature		±0.2			*	*		*	*		*	*	nA/°C
vs Supply		±0.1			*	*		*	*		*	*	nA/V
Initial Offset Current		±15	±30		±10	*		±5	±20		*	*	nA
vs Temperature		±0.5			*	*		*	*		*	*	nA/°C
INPUT IMPEDANCE													Ω pF
Differential		10 ¹⁰ 3			*	*		*	*		*	*	Ω pF
Common-mode		10 ¹⁰ 3			*	*		*	*		*	*	Ω pF
INPUT VOLTAGE RANGE													V
Range, Linear Response	±10	±12		*	*	*	*	*	*	*	*	*	V
CMR with 1kΩ Source Imbalance					*	*		*	*		*	*	dB
DC to 60Hz, G = 1	80	90			*	*		*	*	65	85		dB
DC to 60Hz, G = 10	96	106			*	*		*	*	90	95		dB
DC to 60Hz, G = 100 to 1000	106	110			*	*		*	*	100	105		dB
INPUT NOISE													μV, p-p
Input Voltage Noise					*	*		*	*		*	*	μV, p-p
f _B = 0.01Hz to 10Hz		0.8			*	*		*	*		*	*	μV, p-p
Density, G = 1000					*	*		*	*		*	*	nV/√Hz
f ₀ = 10Hz		18			*	*		*	*		*	*	nV/√Hz
f ₀ = 100Hz		15			*	*		*	*		*	*	nV/√Hz
f ₀ = 1kHz		13			*	*		*	*		*	*	nV/√Hz
Input Current Noise					*	*		*	*		*	*	pA, p-p
f _B = 0.01Hz to 10Hz		50			*	*		*	*		*	*	pA, p-p
Density					*	*		*	*		*	*	pA/√Hz
f ₀ = 10Hz		0.8			*	*		*	*		*	*	pA/√Hz
f ₀ = 100Hz		0.46			*	*		*	*		*	*	pA/√Hz
f ₀ = 1kHz		0.35			*	*		*	*		*	*	pA/√Hz
DYNAMIC RESPONSE													kHz
Small Signal, ±3dB Flatness					*	*		*	*		*	*	kHz
G = 1		300			*	*		*	*		*	*	kHz
G = 10		140			*	*		*	*		*	*	kHz
G = 100		25			*	*		*	*		*	*	kHz
G = 1000		2.5			*	*		*	*		*	*	kHz
Small Signal, ±1% Flatness					*	*		*	*		*	*	kHz
G = 1		20			*	*		*	*		*	*	kHz
G = 10		10			*	*		*	*		*	*	kHz
G = 100		1			*	*		*	*		*	*	Hz
G = 1000		200			*	*		*	*		*	*	Hz
Full Power, G = 1 to 100		6.4			*	*		*	*		*	*	kHz
Slew Rate, G = 1 to 100	0.2	0.4		*	*	*	*	*	*	*	*	*	V/μs
Settling Time (0.1%)					*	*		*	*		*	*	μs
G = 1		30	40		*	*		*	*		*	*	μs
G = 100		40	55		*	*		*	*		*	*	μs
G = 1000		350	470		*	*		*	*		*	*	μs
Settling Time (0.01%)					*	*		*	*		*	*	μs
G = 1		30	45		*	*		*	*		*	*	μs
G = 100		50	70		*	*		*	*		*	*	μs
G = 1000		500	650		*	*		*	*		*	*	μs
POWER SUPPLY													V
Rated Voltage		±15		*	*	*	*	*	*	*	*	*	V
Voltage Range	±5		±20	*	*	*	*	*	*	*	*	*	V
Current, Quiescent ⁽²⁾		±6.7	±8.5		*	*		*	*		*	*	mA
TEMPERATURE RANGE⁽⁶⁾													°C
Specification	-25		+85	-55		+125	*	*	*	0		+70	°C
Operation	-55		+125	*		*	*	*	*	-25		+85	°C
Storage	-65		+150	*		*	*	*	*	-40		+85	°C

* Specifications same as for INA101AM, AG.

NOTES: (1) Typically the tolerance of R_G will be the major source of gain error. (2) Nonlinearity is the maximum peak deviation from the best straight-line as a percentage of peak-to-peak full scale output. (3) Not including the TCR of R_G. (4) Adjustable to zero at any one gain. (5) θ_{IC} output stage = 113°C/W, θ_{IC} quiescent circuitry = 19°C/W, θ_{CA} = 83°C/W.



INA101

PIN CONFIGURATIONS

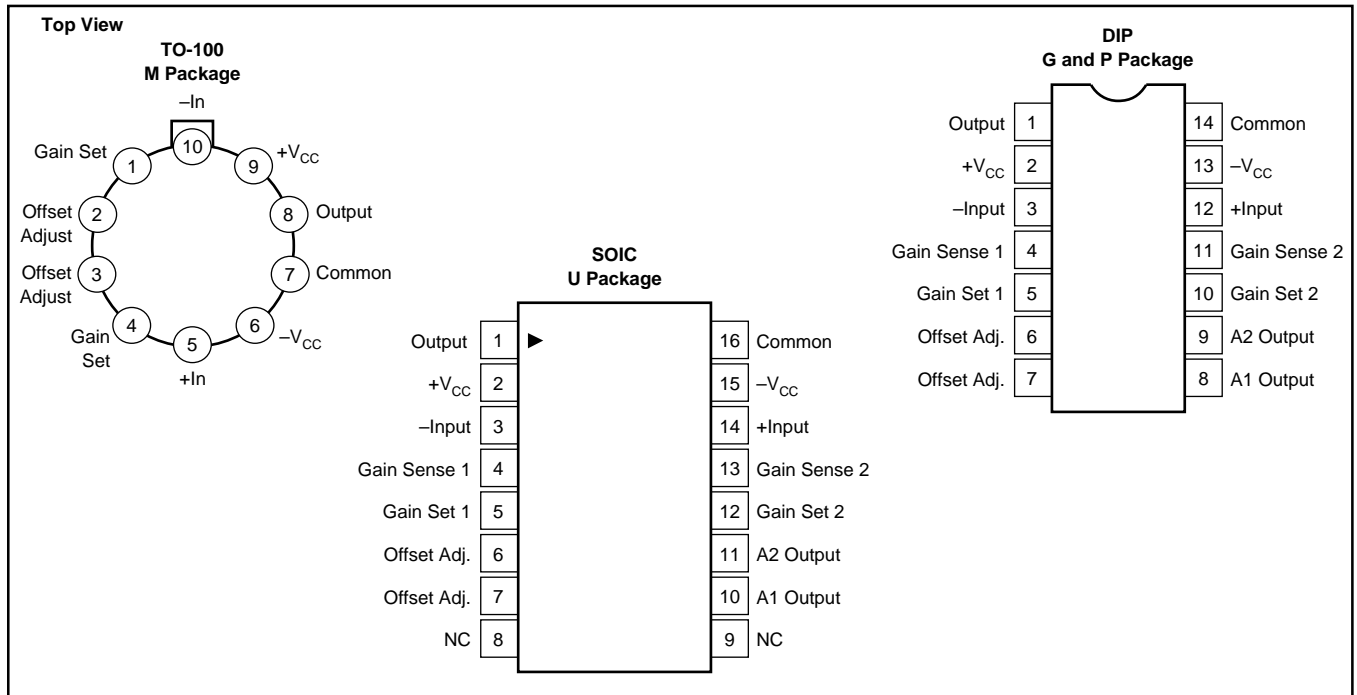

ORDERING INFORMATION

PRODUCT	PACKAGE	TEMPERATURE RANGE
INA101AM	10-Pin Metal TO-100	-25°C to +85°C
INA101CM	10-Pin Metal TO-100	-25°C to +85°C
INA101AG	14-Pin Ceramic DIP	-25°C to +85°C
INA101CG	14-Pin Ceramic DIP	-25°C to +85°C
INA101HP	14-Pin Plastic DIP	0°C to +70°C
INA101KU	SOL-16 Surface-Mount	0°C to +70°C
INA101SG	14-Pin Ceramic DIP	-55°C to +125°C
INA101SM	10-Pin Metal TO-100	-55°C to +125°C

ABSOLUTE MAXIMUM RATINGS

Supply Voltage	±20V
Power Dissipation	600mW
Input Voltage Range	±V _{CC}
Output Short Circuit (to ground)	Continuous
Operating Temperature M, G Package	-55°C to +125°C
P, U Package	-25°C to +85°C
Storage Temperature M, G Package	-65°C to +150°C
P, U Package	-40°C to +85°C
Lead Temperature (soldering, 10s) M, G, P Package	+300°C
Lead Temperature (wave soldering, 3s) U Package	+260°C

PACKAGE INFORMATION

PRODUCT	PACKAGE	PACKAGE DRAWING NUMBER ⁽¹⁾
INA101AM	10-Pin Metal TO-100	007
INA101CM	10-Pin Metal TO-100	007
INA101AG	14-Pin Ceramic DIP	169
INA101CG	14-Pin Ceramic DIP	169
INA101HP	14-Pin Plastic DIP	010
INA101KU	SOL-16 Surface-Mount	211
INA101SG	14-Pin Ceramic DIP	169
INA101SM	10-Pin Metal TO-100	007

NOTE: (1) For detailed drawing and dimension table, please see end of data sheet, or Appendix D of Burr-Brown IC Data Book.



ELECTROSTATIC DISCHARGE SENSITIVITY

This integrated circuit can be damaged by ESD. Burr-Brown recommends that all integrated circuits be handled with appropriate precautions. Failure to observe proper handling and installation procedures can cause damage.

ESD damage can range from subtle performance degradation to complete device failure. Precision integrated circuits may be more susceptible to damage because very small parametric changes could cause the device not to meet its published specifications.

The information provided herein is believed to be reliable; however, BURR-BROWN assumes no responsibility for inaccuracies or omissions. BURR-BROWN assumes no responsibility for the use of this information, and all use of such information shall be entirely at the user's own risk. Prices and specifications are subject to change without notice. No patent rights or licenses to any of the circuits described herein are implied or granted to any third party. BURR-BROWN does not authorize or warrant any BURR-BROWN product for use in life support devices and/or systems.

TYPICAL PERFORMANCE CURVES

At +25°C, $V_{CC} = \pm 15V$ unless otherwise noted.

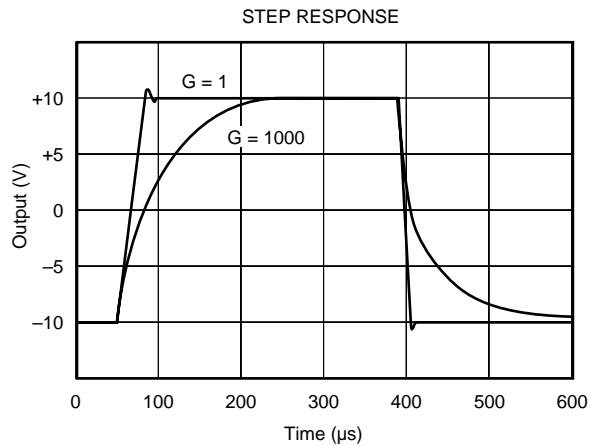
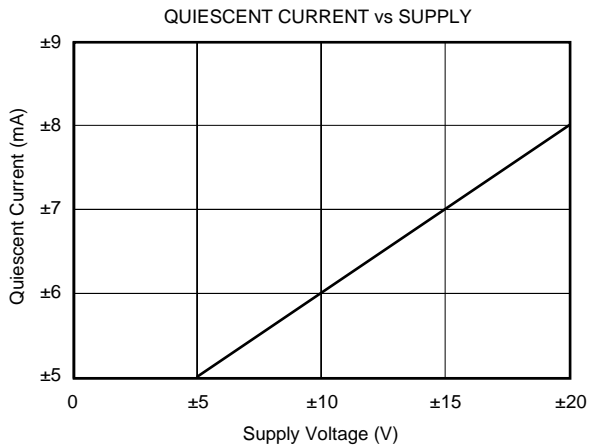
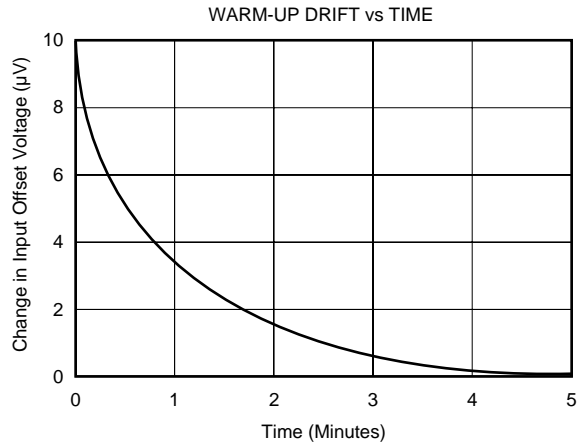
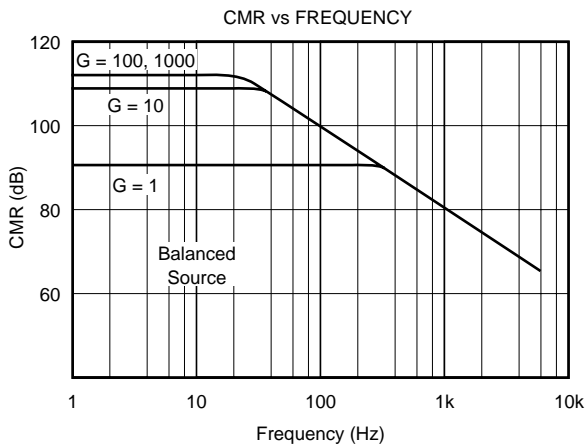
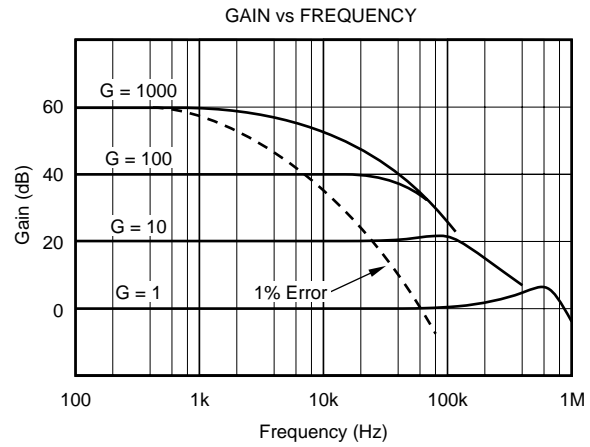
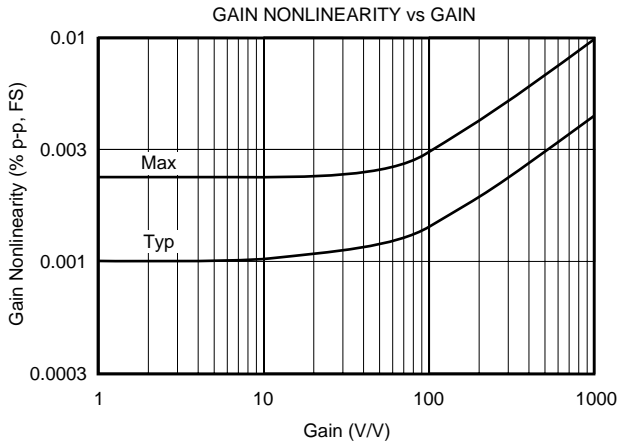

TYPICAL PERFORMANCE CURVES (CONT)

At +25°C, $V_{CC} = \pm 15V$ unless otherwise noted.

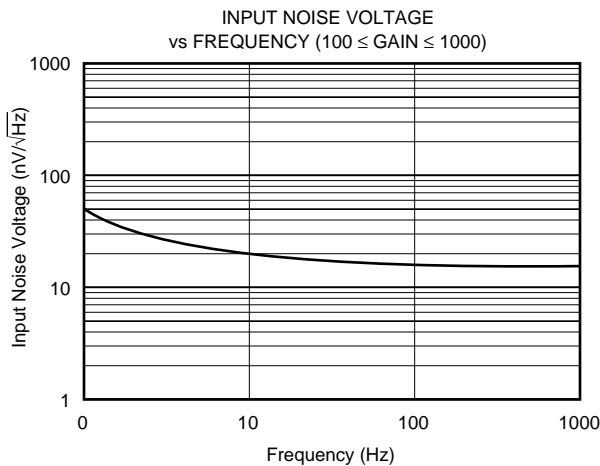
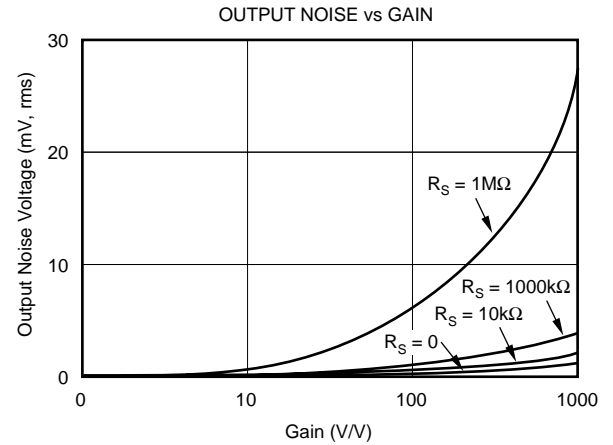
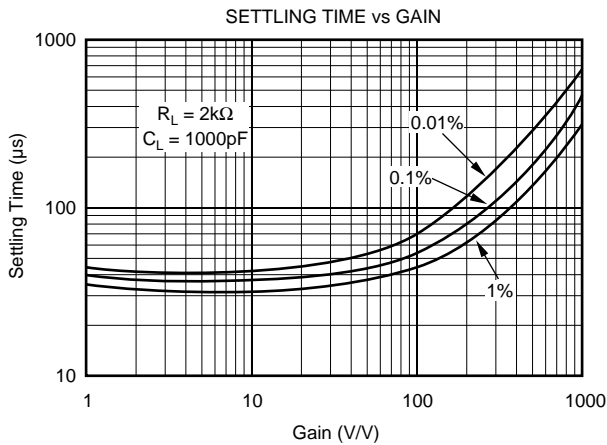

APPLICATION INFORMATION

Figure 1 shows the basic connections required for operation of the INA101. (Pin numbers shown are for the TO-100 metal package.) Applications with noisy or high impedance power supplies may require decoupling capacitors close to the device pins as shown.

The output is referred to the output Common terminal which is normally grounded. This must be a low-impedance connection to assure good common-mode rejection. A resistance greater than 0.1Ω in series with the Common pin will cause common-mode rejection to fall below 106dB.

SETTING THE GAIN

Gain of the INA101 is set by connecting a single external resistor, R_G :

$$G = 1 + \frac{40k\Omega}{R_G} \quad (1)$$

The $40k\Omega$ term in equation (1) comes from the sum of the two internal feedback resistors. These are on-chip metal film resistors which are laser trimmed to accurate absolute values. The accuracy and temperature coefficient of these resistors are included in the gain accuracy and drift specifications of the INA101.

The stability and temperature drift of the external gain setting resistor, R_G , also affects gain. R_G 's contribution to gain accuracy and drift can be directly inferred from the gain equation (1). Low resistor values required for high gain can make wiring resistance important. Sockets add to the wiring resistance which will contribute additional gain error (possibly an unstable gain error) in gains of approximately 100 or greater. The gain sense connections on the DIP and SOL-16 packages (see Figure 2) reduce the gain error produced by wiring or socket resistance.

OFFSET TRIMMING

The INA101 is laser trimmed for low offset voltage and drift. Most applications require no external offset adjustment. Figure 2 shows connection of an optional potentiometer connected to the Offset Adjust pins for trimming the input offset voltage. (Pin numbers shown are for the DIP package.) Use this adjustment to null the offset voltage in high gain ($G \geq 100$) with both inputs connected to ground. Do not use this adjustment to null offset produced by the source or other system offset since this will increase the offset voltage drift by $0.3\mu\text{V}/^\circ\text{C}$ per $100\mu\text{V}$ of adjusted offset.

Offset of the output amplifier usually dominates when the INA101 is used in unity gain ($G = 1$). The output offset

voltage can be adjusted with the optional trim circuit connected to the Common pin as shown in Figure 2. The voltage applied to Common terminal is summed with the output. Low impedance must be maintained at this node to assure good common-mode rejection. The op amp connected as a buffer provides low impedance.

THERMAL EFFECTS ON OFFSET VOLTAGE

To achieve lowest offset voltage and drift, prevent air currents from circulating near the INA101. Rapid changes in temperature will produce a thermocouple effect on the package leads that will degrade offset voltage and drift. A shield or cover that prevents air currents from flowing near the INA101 will assure best performance.

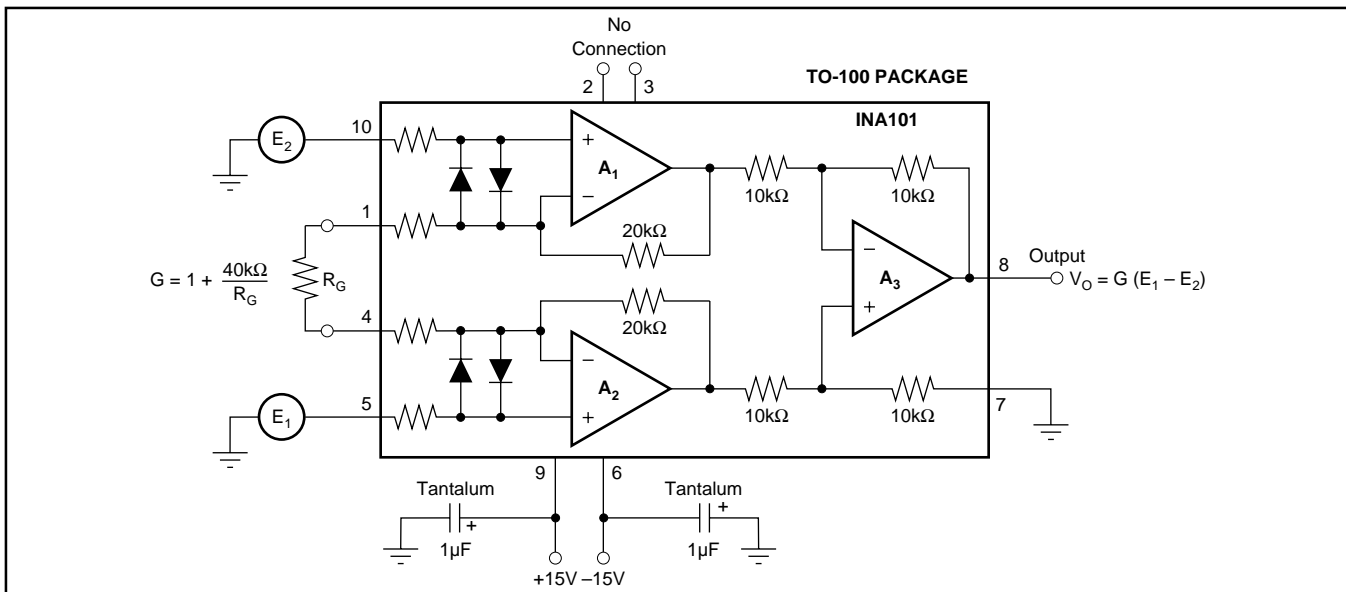

FIGURE 1. Basic Connections.

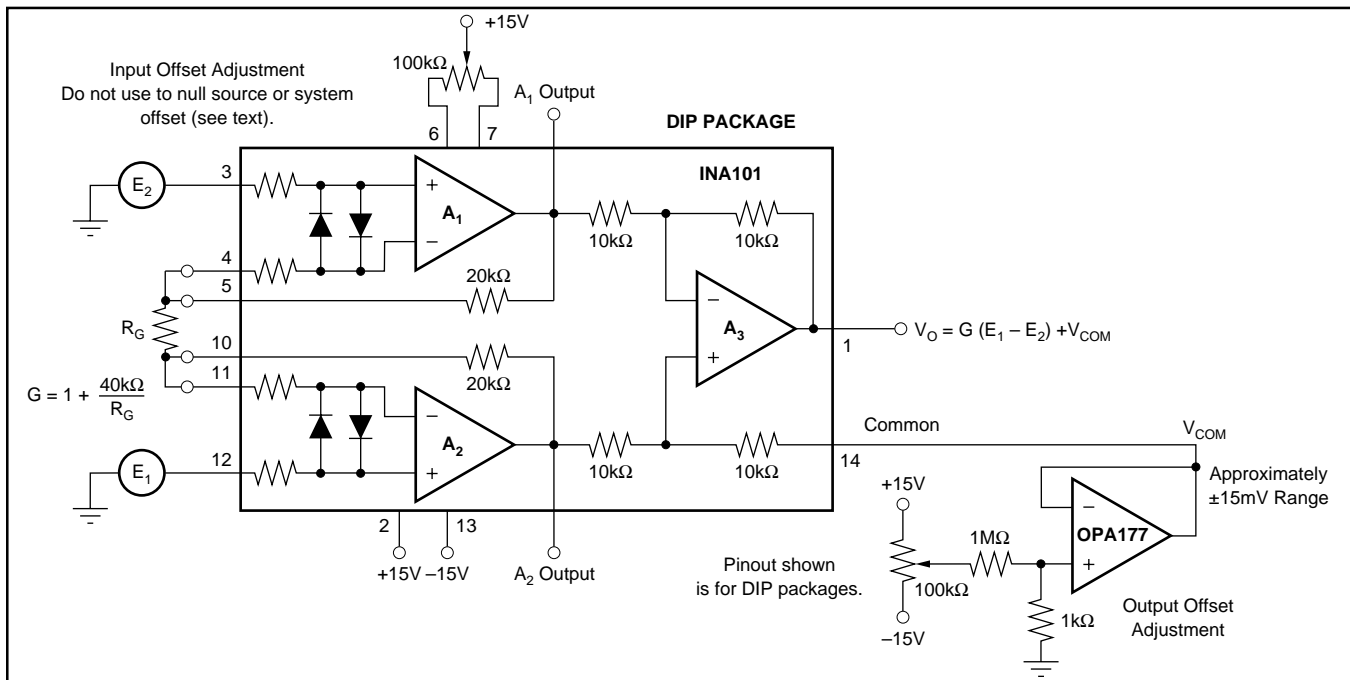

FIGURE 2. Optional Trimming of Input and Output Offset Voltage.

PACKAGING INFORMATION

Orderable Device	Status ⁽¹⁾	Package Type	Package Drawing	Pins	Package Qty	Eco Plan ⁽²⁾	Lead/Ball Finish	MSL Peak Temp ⁽³⁾
INA101AG	NRND	CDIP SB	JD	14	1	Green (RoHS & no Sb/Br)	AU	N / A for Pkg Type
INA101AM	NRND	TO-100	LME	10	20	Green (RoHS & no Sb/Br)	AU	N / A for Pkg Type
INA101AM2	OBSOLETE	TO-100	LME	10		TBD	Call TI	Call TI
INA101CM	NRND	TO-100	LME	10	100	Green (RoHS & no Sb/Br)	AU	N / A for Pkg Type
INA101CM1	OBSOLETE	TO-100	LME	10		TBD	Call TI	Call TI
INA101HP	ACTIVE	PDIP	N	14	25	Green (RoHS & no Sb/Br)	CU NIPDAU	N / A for Pkg Type
INA101HPG4	ACTIVE	PDIP	N	14	25	Green (RoHS & no Sb/Br)	CU NIPDAU	N / A for Pkg Type
INA101KU	ACTIVE	SOIC	DW	16	40	Green (RoHS & no Sb/Br)	CU NIPDAU	Level-3-260C-168 HR
INA101KU/1K	ACTIVE	SOIC	DW	16	1000	Green (RoHS & no Sb/Br)	CU NIPDAU	Level-3-260C-168 HR
INA101KU/1KE4	ACTIVE	SOIC	DW	16	1000	Green (RoHS & no Sb/Br)	CU NIPDAU	Level-3-260C-168 HR
INA101KUE4	ACTIVE	SOIC	DW	16	40	Green (RoHS & no Sb/Br)	CU NIPDAU	Level-3-260C-168 HR
INA101SG1	OBSOLETE	TO-100	LME	10		TBD	Call TI	Call TI
INA101SM	NRND	TO-100	LME	10	20	Green (RoHS & no Sb/Br)	AU	N / A for Pkg Type

⁽¹⁾ The marketing status values are defined as follows:

ACTIVE: Product device recommended for new designs.

LIFEBUY: TI has announced that the device will be discontinued, and a lifetime-buy period is in effect.

NRND: Not recommended for new designs. Device is in production to support existing customers, but TI does not recommend using this part in a new design.

PREVIEW: Device has been announced but is not in production. Samples may or may not be available.

OBSOLETE: TI has discontinued the production of the device.

⁽²⁾ Eco Plan - The planned eco-friendly classification: Pb-Free (RoHS), Pb-Free (RoHS Exempt), or Green (RoHS & no Sb/Br) - please check <http://www.ti.com/productcontent> for the latest availability information and additional product content details.

TBD: The Pb-Free/Green conversion plan has not been defined.

Pb-Free (RoHS): TI's terms "Lead-Free" or "Pb-Free" mean semiconductor products that are compatible with the current RoHS requirements for all 6 substances, including the requirement that lead not exceed 0.1% by weight in homogeneous materials. Where designed to be soldered at high temperatures, TI Pb-Free products are suitable for use in specified lead-free processes.

Pb-Free (RoHS Exempt): This component has a RoHS exemption for either 1) lead-based flip-chip solder bumps used between the die and package, or 2) lead-based die adhesive used between the die and leadframe. The component is otherwise considered Pb-Free (RoHS compatible) as defined above.

Green (RoHS & no Sb/Br): TI defines "Green" to mean Pb-Free (RoHS compatible), and free of Bromine (Br) and Antimony (Sb) based flame retardants (Br or Sb do not exceed 0.1% by weight in homogeneous material)

⁽³⁾ MSL, Peak Temp. -- The Moisture Sensitivity Level rating according to the JEDEC industry standard classifications, and peak solder temperature.

Important Information and Disclaimer:The information provided on this page represents TI's knowledge and belief as of the date that it is provided. TI bases its knowledge and belief on information provided by third parties, and makes no representation or warranty as to the accuracy of such information. Efforts are underway to better integrate information from third parties. TI has taken and continues to take reasonable steps to provide representative and accurate information but may not have conducted destructive testing or chemical analysis on incoming materials and chemicals. TI and TI suppliers consider certain information to be proprietary, and thus CAS numbers and other limited information may not be available for release.

In no event shall TI's liability arising out of such information exceed the total purchase price of the TI part(s) at issue in this document sold by TI to Customer on an annual basis.

TAPE AND REEL INFORMATION



QUADRANT ASSIGNMENTS FOR PIN 1 ORIENTATION IN TAPE



*All dimensions are nominal

Device	Package Type	Package Drawing	Pins	SPQ	Reel Diameter (mm)	Reel Width W1 (mm)	A0 (mm)	B0 (mm)	K0 (mm)	P1 (mm)	W (mm)	Pin1 Quadrant
INA101KU/1K	SOIC	DW	16	1000	330.0	16.4	10.85	10.8	2.7	12.0	16.0	Q1

TAPE AND REEL BOX DIMENSIONS



*All dimensions are nominal

Device	Package Type	Package Drawing	Pins	SPQ	Length (mm)	Width (mm)	Height (mm)
INA101KU/1K	SOIC	DW	16	1000	346.0	346.0	33.0

IMPORTANT NOTICE

Texas Instruments Incorporated and its subsidiaries (TI) reserve the right to make corrections, modifications, enhancements, improvements, and other changes to its products and services at any time and to discontinue any product or service without notice. Customers should obtain the latest relevant information before placing orders and should verify that such information is current and complete. All products are sold subject to TI's terms and conditions of sale supplied at the time of order acknowledgment.

TI warrants performance of its hardware products to the specifications applicable at the time of sale in accordance with TI's standard warranty. Testing and other quality control techniques are used to the extent TI deems necessary to support this warranty. Except where mandated by government requirements, testing of all parameters of each product is not necessarily performed.

TI assumes no liability for applications assistance or customer product design. Customers are responsible for their products and applications using TI components. To minimize the risks associated with customer products and applications, customers should provide adequate design and operating safeguards.

TI does not warrant or represent that any license, either express or implied, is granted under any TI patent right, copyright, mask work right, or other TI intellectual property right relating to any combination, machine, or process in which TI products or services are used. Information published by TI regarding third-party products or services does not constitute a license from TI to use such products or services or a warranty or endorsement thereof. Use of such information may require a license from a third party under the patents or other intellectual property of the third party, or a license from TI under the patents or other intellectual property of TI.

Reproduction of TI information in TI data books or data sheets is permissible only if reproduction is without alteration and is accompanied by all associated warranties, conditions, limitations, and notices. Reproduction of this information with alteration is an unfair and deceptive business practice. TI is not responsible or liable for such altered documentation. Information of third parties may be subject to additional restrictions.

Resale of TI products or services with statements different from or beyond the parameters stated by TI for that product or service voids all express and any implied warranties for the associated TI product or service and is an unfair and deceptive business practice. TI is not responsible or liable for any such statements.

TI products are not authorized for use in safety-critical applications (such as life support) where a failure of the TI product would reasonably be expected to cause severe personal injury or death, unless officers of the parties have executed an agreement specifically governing such use. Buyers represent that they have all necessary expertise in the safety and regulatory ramifications of their applications, and acknowledge and agree that they are solely responsible for all legal, regulatory and safety-related requirements concerning their products and any use of TI products in such safety-critical applications, notwithstanding any applications-related information or support that may be provided by TI. Further, Buyers must fully indemnify TI and its representatives against any damages arising out of the use of TI products in such safety-critical applications.

TI products are neither designed nor intended for use in military/aerospace applications or environments unless the TI products are specifically designated by TI as military-grade or "enhanced plastic." Only products designated by TI as military-grade meet military specifications. Buyers acknowledge and agree that any such use of TI products which TI has not designated as military-grade is solely at the Buyer's risk, and that they are solely responsible for compliance with all legal and regulatory requirements in connection with such use.

TI products are neither designed nor intended for use in automotive applications or environments unless the specific TI products are designated by TI as compliant with ISO/TS 16949 requirements. Buyers acknowledge and agree that, if they use any non-designated products in automotive applications, TI will not be responsible for any failure to meet such requirements.

Following are URLs where you can obtain information on other Texas Instruments products and application solutions:

Products

Amplifiers	amplifier.ti.com
Data Converters	dataconverter.ti.com
DLP® Products	www.dlp.com
DSP	dsp.ti.com
Clocks and Timers	www.ti.com/clocks
Interface	interface.ti.com
Logic	logic.ti.com
Power Mgmt	power.ti.com
Microcontrollers	microcontroller.ti.com
RFID	www.ti-rfid.com
RF/IF and ZigBee® Solutions	www.ti.com/lprf

Applications

Audio	www.ti.com/audio
Automotive	www.ti.com/automotive
Broadband	www.ti.com/broadband
Digital Control	www.ti.com/digitalcontrol
Medical	www.ti.com/medical
Military	www.ti.com/military
Optical Networking	www.ti.com/opticalnetwork
Security	www.ti.com/security
Telephony	www.ti.com/telephony
Video & Imaging	www.ti.com/video
Wireless	www.ti.com/wireless

Mailing Address: Texas Instruments, Post Office Box 655303, Dallas, Texas 75265
Copyright © 2009, Texas Instruments Incorporated