



Description

The ICS553 is a low skew, single input to four output, clock buffer. Part of ICS' ClockBlocks™ family, this is our lowest skew, small clock buffer.

See the ICS552-02 for a 1 to 8 low skew buffer. For more than 8 outputs see the MK74CBxxx Buffalo™ series of clock drivers.

ICS makes many non-PLL and PLL based low skew output devices as well as Zero Delay Buffers to synchronize clocks. Contact us for all of your clocking needs.

Features

- Extremely low skew outputs (50 ps maximum)
- Packaged in 8-pin SOIC
- Available in Pb (lead) free package
- Low power CMOS technology
- Operating Voltages of 2.5 to 5V
- Output Enable pin tri-states outputs
- 5V tolerant input clock
- Industrial temperature

Block Diagram

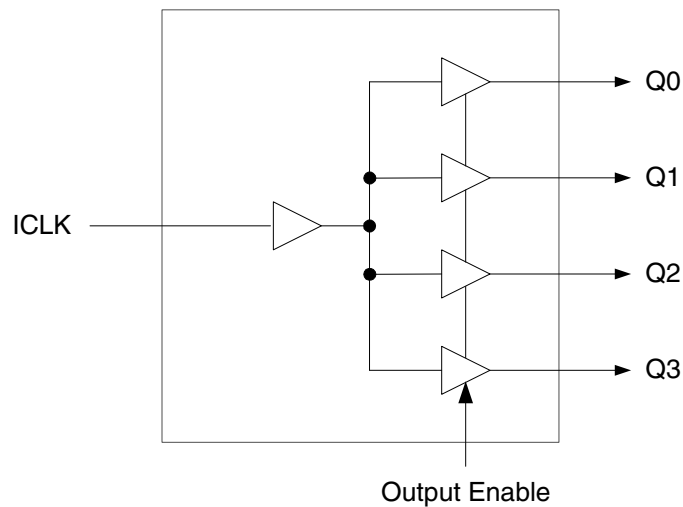



Pin Assignment

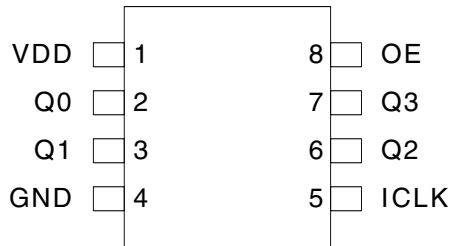

8 Pin (150 mil) SOIC

Pin Descriptions

Pin Number	Pin Name	Pin Type	Pin Description
1	VDD	Power	Connect to +2.5V, +3.3V or +5.0V.
2	Q0	Output	Clock Output 0.
3	Q1	Output	Clock Output 1.
4	GND	Power	Connect to ground.
5	ICLK	Input	Clock Input. 5V tolerant input.
6	Q2	Output	Clock Output 2.
7	Q3	Output	Clock Output 3.
8	OE	Input	Output Enable. Tri-states outputs when low. Connect to VDD for normal operation.

External Components

A minimum number of external components are required for proper operation. A decoupling capacitor of 0.01 μ F should be connected between VDD on pin 1 and GND on pin 4, as close to the device as possible. A 33 Ω series terminating resistor may be used on each clock output if the trace is longer than 1 inch.

To achieve the low output skew that the ICS553 is capable of, careful attention must be paid to board layout. Essentially, all 4 outputs must have identical terminations, identical loads and identical trace geometries. If they do not, the output skew will be degraded. For example, using a 30 Ω series termination on one output (with 33 Ω on the others) will cause at least 15ps of skew.



Absolute Maximum Ratings

Stresses above the ratings listed below can cause permanent damage to the ICS553. These ratings, which are standard values for ICS commercially rated parts, are stress ratings only. Functional operation of the device at these or any other conditions above those indicated in the operational sections of the specifications is not implied. Exposure to absolute maximum rating conditions for extended periods can affect product reliability. Electrical parameters are guaranteed only over the recommended operating temperature range.

Item	Rating
Supply Voltage, VDD	7V
Output Enable and All Outputs	-0.5V to VDD+0.5V
ICLK	-0.5V to 5.5V
Ambient Operating Temperature	-40 to +85 °C
Storage Temperature	-65 to +150°C
Junction Temperature	175°C
Soldering Temperature	260°C

Recommended Operation Conditions

Parameter	Min.	Typ.	Max.	Units
Ambient Operating Temperature	-40		+85	°C
Power Supply Voltage (measured in respect to GND)	+2.375		+5.25	V

DC Electrical Characteristics

VDD=2.5V ±5%, Ambient temperature -40 to +85 °C, unless stated otherwise

Parameter	Symbol	Conditions	Min.	Typ.	Max.	Units
Operating Voltage	VDD		2.375		2.625	V
Input High Voltage, ICLK	V _{IH}	Note 1	VDD/2+0.5		5.5	V
Input Low Voltage, ICLK	V _{IL}	Note 1			VDD/2-0.5	V
Input High Voltage, OE	V _{IH}		1.8		VDD	V
Input Low Voltage, OE	V _{IL}				0.7	V
Output High Voltage	V _{OH}	I _{OH} = -16 mA	2			V
Output Low Voltage	V _{OL}	I _{OL} = 16 mA			0.4	V
Operating Supply Current	IDD	No load, 135 MHz		25		mA
Nominal Output Impedance	Z _O			20		Ω
Input Capacitance	C _{IN}	ICLK, OE pin		5		pF
Short Circuit Current	I _{OS}			±28		mA

**DC Electrical Characteristics (continued)****VDD=3.3V ±5%** , Ambient temperature -40 to +85 °C, unless stated otherwise

Parameter	Symbol	Conditions	Min.	Typ.	Max.	Units
Operating Voltage	VDD		3.15		3.45	V
Input High Voltage, ICLK	V _{IH}	Note 1	VDD/2+0.7		5.5	V
Input Low Voltage, ICLK	V _{IL}	Note 1			VDD/2-0.7	V
Input High Voltage, OE	V _{IH}		2		VDD	V
Input Low Voltage, OE	V _{IL}				0.8	V
Output High Voltage	V _{OH}	I _{OH} = -25 mA	2.4			V
Output Low Voltage	V _{OL}	I _{OL} = 25 mA			0.4	V
Output High Voltage (CMOS Level)	V _{OH}	I _{OH} = -12 mA	VDD-0.4			V
Operating Supply Current	IDD	No load, 135 MHz		35		mA
Nominal Output Impedance	Z _O			20		Ω
Input Capacitance	C _{IN}	ICLK, OE pin		5		pF
Short Circuit Current	I _{OS}			±50		mA

VDD=5V ±5% , Ambient temperature -40 to +85 °C, unless stated otherwise

Parameter	Symbol	Conditions	Min.	Typ.	Max.	Units
Operating Voltage	VDD		4.75		5.25	V
Input High Voltage, ICLK	V _{IH}	Note 1	VDD/2+1		5.5	V
Input Low Voltage, ICLK	V _{IL}	Note 1			VDD/2-1	V
Input High Voltage, OE	V _{IH}		2		VDD	V
Input Low Voltage, OE	V _{IL}				0.8	V
Output High Voltage	V _{OH}	I _{OH} = -35 mA	2.4			V
Output Low Voltage	V _{OL}	I _{OL} = 35 mA			0.4	V
Output High Voltage (CMOS Level)	V _{OH}	I _{OH} = -12 mA	VDD-0.4			V
Operating Supply Current	IDD	No load, 135 MHz		45		mA
Nominal Output Impedance	Z _O			20		Ω
Input Capacitance	C _{IN}	ICLK, OE pin		5		pF
Short Circuit Current	I _{OS}			±80		mA

Notes: 1. Nominal switching threshold is VDD/2



AC Electrical Characteristics

VDD = 2.5V ±5%, Ambient Temperature -40 to +85 °C, unless stated otherwise

Parameter	Symbol	Conditions	Min.	Typ.	Max.	Units
Input Frequency			0		200	MHz
Output Rise Time	t _{OR}	0.8 to 2.0V, C _L =15pF		1.0	1.5	ns
Output Fall Time	t _{OF}	2.0 to 0.8V, C _L =15pF		1.0	1.5	ns
Propagation Delay	Note 1		2.2	3	5	ns
Output to output skew	Note 2	Rising edges at VDD/2		0	50	ps
Device to device skew		Rising edges at VDD/2			500	ps

VDD = 3.3V ±5%, Ambient Temperature -40 to +85 °C, unless stated otherwise

Parameter	Symbol	Conditions	Min.	Typ.	Max.	Units
Input Frequency			0		200	MHz
Output Rise Time	t _{OR}	0.8 to 2.0V, C _L =15pF		0.6	1.0	ns
Output Fall Time	t _{OF}	2.0 to 0.8V, C _L =15pF		0.6	1.0	ns
Propagation Delay	Note 1		2.0	2.4	4	ns
Output to output skew	Note 2	Rising edges at VDD/2		0	50	ps
Device to device skew		Rising edges at VDD/2			500	ps

VDD = 5V ±5%, Ambient Temperature -40 to +85 °C, unless stated otherwise

Parameter	Symbol	Conditions	Min.	Typ.	Max.	Units
Input Frequency			0		200	MHz
Output Rise Time	t _{OR}	0.8 to 2.0V, C _L =15pF		0.3	0.7	ns
Output Fall Time	t _{OF}	2.0 to 0.8V, C _L =15pF		0.3	0.7	ns
Propagation Delay	Note 1		1.8	2.5	4	ns
Output to output skew	Note 2	Rising edges at VDD/2		0	50	ps
Device to device skew		Rising edges at VDD/2			500	ps

Notes: 1. With rail to rail input clock

2. Between any 2 outputs with equal loading.

3. Duty cycle on outputs will match incoming clock duty cycle. Consult ICS for tight duty cycle clock generators.

Thermal Characteristics

Parameter	Symbol	Conditions	Min.	Typ.	Max.	Units
Thermal Resistance Junction to Ambient	θ _{JA}	Still air		150		°C/W
	θ _{JA}	1 m/s air flow		140		°C/W
	θ _{JA}	3 m/s air flow		120		°C/W
Thermal Resistance Junction to Case	θ _{JC}			40		°C/W



Package Outline and Package Dimensions (8 pin SOIC, 150 Mil. Narrow Body)

Package dimensions are kept current with JEDEC Publication No. 95

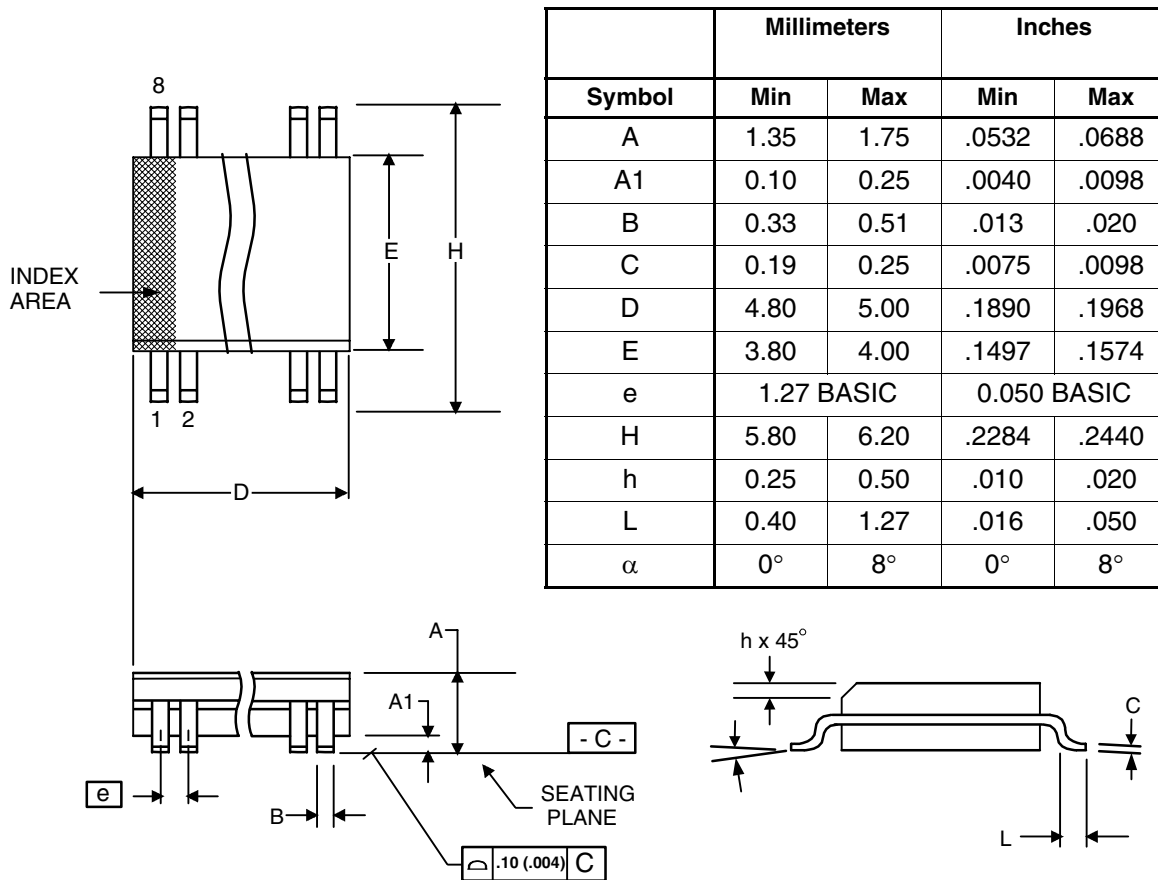

Ordering Information

Part / Order Number	Marking	Shipping Packaging	Package	Temperature
ICS553MI	553MI	Tubes	8-pin SOIC	-40 to +85 °C
ICS553MIT	553MI	Tape and Reel	8-pin SOIC	-40 to +85 °C
ICS553MILF	553MILF	Tubes	8-pin SOIC	-40 to +85 °C
ICS553MILFT	553MILF	Tape and Reel	8-pin SOIC	-40 to +85 °C

“LF” denotes Pb (lead) free package.

While the information presented herein has been checked for both accuracy and reliability, Integrated Circuit Systems (ICS) result from its use. No other circuits, patents, or licenses are implied. This product is intended for use in normal commercial applications. Any other applications such as those requiring extended temperature range, high reliability, or other extraordinary environmental requirements are not recommended without additional processing by ICS. ICS reserves the right to change any circuitry or specifications without notice. ICS does not authorize or warrant any ICS product for use in life support devices or critical medical instruments.