

# High Performance 6-Axis MEMS MotionTracking™ Device

## GENERAL DESCRIPTION

The ICM-20689 is a 6-axis MotionTracking device that combines a 3-axis gyroscope, 3-axis accelerometer, and a Digital Motion Processor™ (DMP) in a small 4x4x0.9mm (24-pin QFN) package.

- Large 4K-byte FIFO to reduce traffic on the serial bus interface, and reduce power consumption by allowing the system processor to burst read sensor data and then go into a low-power mode
- Gyroscope programmable FSR of  $\pm 250\text{dps}$ ,  $\pm 500\text{dps}$ ,  $\pm 1000\text{dps}$  and  $\pm 2000\text{dps}$
- Accelerometer with Programmable FSR of  $\pm 2g$ ,  $\pm 4g$ ,  $\pm 8g$  and  $\pm 16g$
- EIS FSYNC support

ICM-20689 includes on-chip 16-bit ADCs, programmable digital filters, an embedded temperature sensor, and programmable interrupts. The device features an operating voltage range down to 1.71 V. Communication ports include I<sup>2</sup>C and high speed SPI at 8 MHz.

## APPLICATIONS

- Mobile phones and tablets
- Drones
- Motion-based game controllers
- 3D remote controls for Internet connected DTVs and set top boxes, 3D mice
- Wearable sensors for health, fitness and sports

## FEATURES

- User-programmable interrupts
- Wake-on-motion interrupt for low power operation of applications processor
- 4K-byte FIFO buffer enables the applications processor to read the data in bursts
- On-Chip 16-bit ADCs and Programmable Filters
- Host interface: 8 MHz SPI or 400 kHz Fast Mode I<sup>2</sup>C
- Digital-output temperature sensor
- VDD operating range of 1.71 V to 3.45 V
- MEMS structure hermetically sealed and bonded at wafer level
- RoHS and Green compliant

## ORDERING INFORMATION

PART	TEMP RANGE	PACKAGE
ICM-20689†	-40°C to +85°C	24-Pin QFN

†Denotes RoHS and Green-Compliant Package

## BLOCK DIAGRAM

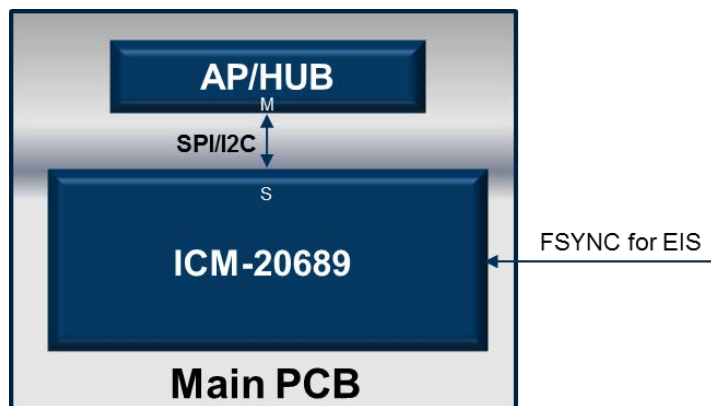

## TYPICAL OPERATING CIRCUIT

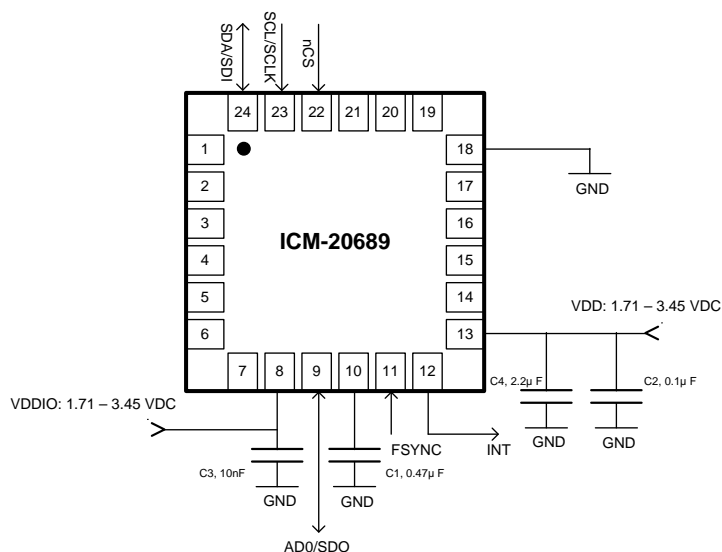

**TABLE OF CONTENTS**

	General Description .....	1
	Ordering Information.....	1
	Block Diagram .....	1
	Applications .....	1
	Features .....	1
	Typical Operating Circuit.....	1
1	INTRODUCTION.....	7
	1.1 Purpose and Scope.....	7
	1.2 Product Overview.....	7
	1.3 Applications.....	7
2	Features .....	8
	2.1 Gyroscope Features .....	8
	2.2 Accelerometer Features.....	8
	2.3 Additional Features .....	8
	2.4 Motion Processing .....	8
3	Electrical Characteristics .....	9
	3.1 Gyroscope Specifications .....	9
	3.2 Accelerometer Specifications.....	10
	3.3 Electrical Specifications.....	11
	3.4 I <sup>2</sup> C Timing Characterization.....	15
	3.5 SPI Timing Characterization .....	16
	3.6 Absolute Maximum Ratings .....	17
4	Applications Information .....	18
	4.1 Pin Out Diagram and Signal Description .....	18
	4.2 Typical Operating Circuit.....	19
	4.3 Bill of Materials for External Components .....	19
	4.4 Block Diagram .....	20
	4.5 Overview .....	20
	4.6 Three-Axis MEMS Gyroscope with 16-bit ADCs and Signal Conditioning .....	21
	4.7 Three-Axis MEMS Accelerometer with 16-bit ADCs and Signal Conditioning.....	21
	4.8 Digital Motion Processor.....	21
	4.9 I <sup>2</sup> C and SPI Serial Communications Interfaces .....	21
	4.10 Self-Test .....	23
	4.11 Clocking.....	23
	4.12 Sensor Data Registers .....	23
	4.13 FIFO.....	24
	4.14 Interrupts.....	24
	4.15 Digital-Output Temperature Sensor .....	24

4.16	Bias and LDOs .....	24
4.17	Charge Pump .....	24
4.18	Standard Power Modes .....	24
5	Programmable Interrupts .....	25
5.1	Wake-on-Motion Interrupt .....	26
6	Digital Interface .....	27
6.1	I <sup>2</sup> C and SPI Serial Interfaces .....	27
6.2	I <sup>2</sup> C Interface.....	27
6.3	I <sup>2</sup> C Communications Protocol .....	27
6.4	I <sup>2</sup> C Terms .....	30
6.5	SPI Interface .....	31
7	Serial Interface Considerations.....	32
7.1	ICM-20689 Supported Interfaces.....	32
8	Assembly.....	33
8.1	Orientation of Axes .....	33
8.2	Package Dimensions.....	34
9	Part Number Package Marking.....	35
10	Register Map.....	36
11	Register Descriptions .....	38
11.1	Registers 0 to 2 – Gyroscope Self-Test Registers.....	38
11.2	Registers 13 to 15 – Accelerometer Self-Test Registers .....	38
11.3	REGISTER 19 – Gyro Offset Adjustment Register.....	39
11.4	Register 20 – Gyro Offset Adjustment Register .....	39
11.5	Register 21 – Gyro Offset Adjustment Register .....	39
11.6	Register 22 – Gyro Offset Adjustment Register .....	40
11.7	Register 23 – Gyro Offset Adjustment Register .....	40
11.8	Register 24 – Gyro Offset Adjustment Register .....	40
11.9	Register 25 – Sample Rate Divider.....	40
11.10	Register 26 – Configuration .....	41
11.11	Register 27 – Gyroscope Configuration .....	42
11.12	Register 28 – Accelerometer Configuration .....	42
11.13	Register 29 – Accelerometer Configuration 2 .....	42
11.14	Register 30 – Low Power Mode Configuration .....	44
11.15	Register 31 – Wake-on Motion Threshold (Accelerometer).....	44
11.16	Register 35 – FIFO Enable .....	45
11.17	Register 54 – FSYNC Interrupt Status .....	45
11.18	Register 55 – INT/DRDY Pin / Bypass Enable Configuration .....	46
11.19	Register 56 – Interrupt Enable.....	46
11.20	Register 57 – DMP Interrupt Status.....	46

---

11.21	Register 58 – Interrupt Status.....	47
11.22	Registers 59 to 64 – Accelerometer Measurements .....	48
11.23	Registers 65 and 66 – Temperature Measurement.....	49
11.24	Registers 67 to 72 – Gyroscope Measurements.....	50
11.25	Register 104 – Signal Path Reset.....	51
11.26	Register 105 – Accelerometer Intelligence Control.....	51
11.27	Register 106 – User Control.....	51
11.28	Register 107 – Power Management 1 .....	52
11.29	Register 108 – Power Management 2 .....	53
11.30	Register 114 and 115 – FIFO Count Registers.....	54
11.31	Register 116 – FIFO Read Write.....	54
11.32	Register 117 – Who Am I .....	55
11.33	Registers 119, 120, 122, 123, 125, 126 Accelerometer Offset Registers.....	55
12	Reference.....	57
13	Revision History .....	58

## LIST OF FIGURES

Figure 1. I <sup>2</sup> C Bus Timing Diagram .....	15
Figure 2. SPI Bus Timing Diagram.....	16
Figure 3. Pin Out Diagram for ICM-20689.....	18
Figure 4. ICM-20689 Application Schematic .....	19
Figure 5. ICM-20689 Block Diagram.....	20
Figure 6. ICM-20689 Solution Using I <sup>2</sup> C Interface.....	22
Figure 7. ICM-20689 Solution Using SPI Interface .....	23
Figure 8. START and STOP Conditions.....	27
Figure 9. Acknowledge on the I <sup>2</sup> C Bus .....	28
Figure 10. Complete I <sup>2</sup> C Data Transfer.....	29
Figure 11. Typical SPI Master/Slave Configuration .....	31
Figure 12. I/O Levels and Connections.....	32
Figure 13. Orientation of Axes of Sensitivity and Polarity of Rotation .....	33

**LIST OF TABLES**

Table 1. Gyroscope Specifications ..... 9  
Table 2. Accelerometer Specifications ..... 10  
Table 3. D.C. Electrical Characteristics ..... 11  
Table 4. A.C. Electrical Characteristics ..... 13  
Table 5. Other Electrical Specifications ..... 14  
Table 6. I<sup>2</sup>C Timing Characteristics ..... 15  
Table 7. SPI Timing Characteristics (8MHz Operation) ..... 16  
Table 8. Absolute Maximum Ratings ..... 17  
Table 9. Signal Descriptions ..... 18  
Table 10. Bill of Materials ..... 19  
Table 11. Standard Power Modes for ICM-20689 ..... 24  
Table 12. Table of Interrupt Sources ..... 25  
Table 13. Serial Interface ..... 27  
Table 14. I<sup>2</sup>C Terms ..... 30

## 1 INTRODUCTION

### 1.1 PURPOSE AND SCOPE

This document is a product specification, providing a description, specifications, and design related information on the ICM-20689 MotionTracking® device. The device is housed in a small 4x4x0.9 mm 24-pin QFN package.

### 1.2 PRODUCT OVERVIEW

The ICM-20689 is a 6-axis MotionTracking device that combines a 3-axis gyroscope, a 3-axis accelerometer, and a Digital Motion Processor™ (DMP) in a small 4x4x0.9 mm (24-pin QFN) package. It also features a 4 Kbyte FIFO that can lower the traffic on the serial bus interface, and reduce power consumption by allowing the system processor to burst read sensor data and then go into a low-power mode. ICM-20689, with its 6-axis integration, on-chip DMP, and run-time calibration firmware, enables manufacturers to eliminate the costly and complex selection, qualification, and system level integration of discrete devices, guaranteeing optimal motion performance.

The gyroscope has a programmable full-scale range of  $\pm 250$ ,  $\pm 500$ ,  $\pm 1000$ , and  $\pm 2000$  degrees/sec. The accelerometer has a user-programmable accelerometer full-scale range of  $\pm 2g$ ,  $\pm 4g$ ,  $\pm 8g$ , and  $\pm 16g$ . Factory-calibrated initial sensitivity of both sensors reduces production-line calibration requirements.

Other industry-leading features include on-chip 16-bit ADCs, programmable digital filters, an embedded temperature sensor, and programmable interrupts. The device features I<sup>2</sup>C and SPI serial interfaces, a VDD operating range of 1.71 V to 3.45 V, and a separate digital IO supply, VDDIO from 1.71 V to 3.45 V. Communication with all registers of the device is performed using either I<sup>2</sup>C at 400 kHz or SPI at 8 MHz.

By leveraging its patented and volume-proven CMOS-MEMS fabrication platform, which integrates MEMS wafers with companion CMOS electronics through wafer-level bonding, InvenSense has driven the package size down to a footprint and thickness of 4x4x0.9 mm (24-pin QFN), to provide a very small yet high-performance, low-cost package. The device provides high robustness by supporting 10,000g shock reliability.

### 1.3 APPLICATIONS

- Mobile phones and tablets
- Drones
- Handset and portable gaming
- Motion-based game controllers
- 3D remote controls for Internet connected DTVs and set top boxes, 3D mice
- Wearable sensors for health, fitness and sports

## 2 FEATURES

### 2.1 GYROSCOPE FEATURES

- Digital-output X-, Y-, and Z-axis angular rate sensors (gyroscopes) with a user-programmable full-scale range of  $\pm 250$ ,  $\pm 500$ ,  $\pm 1000$ , and  $\pm 2000^\circ/\text{sec}$  and integrated 16-bit ADCs
- Digitally-programmable low-pass filter
- Low-power gyroscope operation
- Factory calibrated sensitivity scale factor
- Self-test

### 2.2 ACCELEROMETER FEATURES

- Digital-output X-, Y-, and Z-axis accelerometer with a programmable full scale range of  $\pm 2g$ ,  $\pm 4g$ ,  $\pm 8g$  and  $\pm 16g$  and integrated 16-bit ADCs
- User-programmable interrupts
- Wake-on-motion interrupt for low power operation of applications processor
- Self-test

### 2.3 ADDITIONAL FEATURES

- Smallest and thinnest LGA package for portable devices: 4x4x0.9 mm (24-pin QFN)
- Minimal cross-axis sensitivity between the accelerometer and gyroscope axes
- 4 Kbyte FIFO buffer enables the applications processor to read the data in bursts
- Digital-output temperature sensor
- User-programmable digital filters for gyroscope, accelerometer, and temp sensor
- 10,000 g shock tolerant
- 400 kHz Fast Mode I<sup>2</sup>C for communicating with all registers
- 8 MHz SPI serial interface for communicating with all registers
- MEMS structure hermetically sealed and bonded at wafer level
- RoHS and Green compliant

### 2.4 MOTION PROCESSING

- Internal Digital Motion Processing™ (DMP™) engine supports advanced MotionProcessing and low power functions such as gesture recognition using programmable interrupts.
- DMP operation is possible in low-power gyroscope and low-power accelerometer modes.
- Low-power pedometer functionality allows the host processor to sleep while the DMP maintains the step count.

### 3 ELECTRICAL CHARACTERISTICS

#### 3.1 GYROSCOPE SPECIFICATIONS

Typical Operating Circuit of section 4.2, VDD = 1.8 V, VDDIO = 1.8 V, T<sub>A</sub>=25°C, unless otherwise noted.

PARAMETER	CONDITIONS	MIN	TYP	MAX	UNITS	NOTES
<b>GYROSCOPE SENSITIVITY</b>						
Full-Scale Range	FS_SEL=0		±250		°/s	3
	FS_SEL=1		±500		°/s	3
	FS_SEL=2		±1000		°/s	3
	FS_SEL=3		±2000		°/s	3
Gyroscope ADC Word Length			16		bits	3
Sensitivity Scale Factor	FS_SEL=0		131		LSB/(°/s)	3
	FS_SEL=1		65.5		LSB/(°/s)	3
	FS_SEL=2		32.8		LSB/(°/s)	3
	FS_SEL=3		16.4		LSB/(°/s)	3
Sensitivity Scale Factor Tolerance	Component-Level, 25°C		±2		%	2
Sensitivity Scale Factor Variation Over Temperature	-40°C to +85°C		±1.5		%	1
Nonlinearity	Best fit straight line; 25°C		±0.1		%	1
Cross-Axis Sensitivity			±2		%	1
<b>ZERO-RATE OUTPUT (ZRO)</b>						
Initial ZRO Tolerance	Component-Level, 25°C		±5		°/s	2
ZRO Variation Over Temperature	-40°C to +85°C		±0.04		°/s/°C	1
<b>GYROSCOPE NOISE PERFORMANCE (FS_SEL=0)</b>						
Noise Spectral Density			0.006		°/s/√Hz	1
Gyroscope Mechanical Frequencies		25	27	29	kHz	2
Low Pass Filter Response	Programmable Range	5		250	Hz	3
Gyroscope Start-Up Time	From Sleep mode		35		ms	1
Output Data Rate	Standard (duty-cycled) mode	3.91		500	Hz	1
	Low-Noise (active) mode	4		8000	Hz	1

**Table 1. Gyroscope Specifications**

**Notes:**

1. Derived from validation or characterization of parts, not guaranteed in production.
2. Tested in production.
3. Guaranteed by design.

### 3.2 ACCELEROMETER SPECIFICATIONS

Typical Operating Circuit of section 4.2, VDD = 1.8 V, VDDIO = 1.8 V, T<sub>A</sub> = 25°C, unless otherwise noted.

PARAMETER	CONDITIONS		MIN	TYP	MAX	UNITS	NOTES
<b>ACCELEROMETER SENSITIVITY</b>							
Full-Scale Range	AFS_SEL=0			±2		g	3
	AFS_SEL=1			±4		g	3
	AFS_SEL=2			±8		g	3
	AFS_SEL=3			±16		g	3
ADC Word Length	Output in two's complement format			16		bits	3
Sensitivity Scale Factor	AFS_SEL=0			16,384		LSB/g	3
	AFS_SEL=1			8,192		LSB/g	3
	AFS_SEL=2			4,096		LSB/g	3
	AFS_SEL=3			2,048		LSB/g	3
Initial Tolerance	Component-Level, 25°C			±2		%	2
Sensitivity Change vs. Temperature	-40°C to +85°C AFS_SEL = 0			±1		%	1
Nonlinearity	Best Fit Straight Line			±0.5		%	1
Cross-Axis Sensitivity				±2		%	1
<b>ZERO-G OUTPUT</b>							
Initial Tolerance	Component-Level, 25°C			±20		mg	1
Zero-G Level Change vs. Temperature	-40°C to +85°C	X and Y axes		±0.5		mg/°C	1
		Z axis		±0.75		mg/°C	1
<b>NOISE PERFORMANCE</b>							
Noise Spectral Density				150		µg/√Hz	1
Low Pass Filter Response	Programmable Range		5		218	Hz	3
Intelligence Function Increment				4		mg/LSB	3
Accelerometer Startup Time	From Sleep mode			20		ms	1
	From Cold Start, 1 ms V <sub>DD</sub> ramp			30		ms	1
Output Data Rate	Standard (duty-cycled) mode		0.24		500	Hz	1
	Low-Noise (active) mode		4		4000	Hz	

**Table 2. Accelerometer Specifications**

**Notes:**

1. Derived from validation or characterization of parts, not guaranteed in production.
2. Tested in production.
3. Guaranteed by design.

### 3.3 ELECTRICAL SPECIFICATIONS

#### 3.3.1 D.C. Electrical Characteristics

Typical Operating Circuit of section 4.2, VDD = 1.8 V, VDDIO = 1.8 V, T<sub>A</sub> = 25°C, unless otherwise noted.

PARAMETER	CONDITIONS	MIN	TYP	MAX	UNITS	NOTES
<b>SUPPLY VOLTAGES</b>						
VDD		1.71	1.8	3.45	V	1
VDDIO		1.71	1.8	3.45	V	1
<b>SUPPLY CURRENTS &amp; BOOT TIME</b>						
Normal Mode	6-axis Gyroscope + Accelerometer		3		mA	1
	3-axis Gyroscope		2.6		mA	1
	3-axis Accelerometer, 4 kHz ODR		390		μA	1
Accelerometer Low -Power Mode	100 Hz ODR, 1x averaging		57		μA	2
Gyroscope Low-Power Mode	100 Hz ODR, 1x averaging		1.6		mA	2
6-Axis Low-Power Mode (Gyroscope Low-Power Mode; Accelerometer Low-Noise Mode)	100 Hz ODR, 1x averaging		1.9		mA	2
Full-Chip Sleep Mode			6		μA	1
<b>TEMPERATURE RANGE</b>						
Specified Temperature Range	Performance parameters are not applicable beyond Specified Temperature Range	-40		+85	°C	1

**Table 3. D.C. Electrical Characteristics**

**Notes:**

1. Derived from validation or characterization of parts, not guaranteed in production.
2. Based on simulation.

### 3.3.2 A.C. Electrical Characteristics

Typical Operating Circuit of section 4.2, VDD = 1.8 V, VDDIO = 1.8 V, T<sub>A</sub> = 25°C, unless otherwise noted.

PARAMETER	CONDITIONS	MIN	TYP	MAX	UNITS	NOTES
<b>SUPPLIES</b>						
Supply Ramp Time (T <sub>RAMP</sub> )	Monotonic ramp. Ramp rate is 10% to 90% of the final value	0.01		100	ms	1
<b>TEMPERATURE SENSOR</b>						
Operating Range	Ambient	-40		85	°C	1
Room Temperature Offset	25°C		0		°C	1
Sensitivity	Untrimmed		326.8		LSB/°C	1
<b>POWER-ON RESET</b>						
Supply Ramp Time (T <sub>RAMP</sub> )	Valid power-on RESET	0.01		100	ms	1
Start-up time for register read/write	From power-up		11	100	ms	1
	From sleep			5	ms	1
<b>I<sup>2</sup>C ADDRESS</b>	SA0 = 0		1101000			
	SA0 = 1		1101001			
<b>DIGITAL INPUTS (FSYNC, SA0, SPC, SDI, CS)</b>						
V <sub>IH</sub> , High-Level Input Voltage		0.7*VDDIO			V	1
V <sub>IL</sub> , Low-Level Input Voltage				0.3*VDDIO	V	
C <sub>i</sub> , Input Capacitance			< 10		pF	
<b>DIGITAL OUTPUT (SDO, INT)</b>						
V <sub>OH</sub> , High- Level Output Voltage	R <sub>LOAD</sub> = 1 MΩ;	0.9*VDDIO			V	1
V <sub>OL1</sub> , Low-Level Output Voltage	R <sub>LOAD</sub> = 1 MΩ;			0.1*VDDIO	V	
V <sub>OLINT</sub> , INT Low-Level Output Voltage	OPEN = 1, 0.3 mA sink Current			0.1	V	
Output Leakage Current	OPEN = 1		100		nA	
t <sub>INT</sub> , INT Pulse Width	LATCH_INT_EN = 0		50		μs	
<b>I2C I/O (SCL, SDA)</b>						
V <sub>IL</sub> , Low-Level Input Voltage		-0.5V		0.3*VDDIO	V	1
V <sub>IH</sub> , High-Level Input Voltage		0.7*VDDIO		VDDIO + 0.5V	V	
V <sub>hys</sub> , Hysteresis			0.1*VDDIO		V	
V <sub>OL</sub> , Low-Level Output Voltage	3 mA sink current	0		0.4	V	
I <sub>OL</sub> , Low-Level Output Current	V <sub>OL</sub> = 0.4 V		3		mA	
	V <sub>OL</sub> = 0.6 V		6		mA	
Output Leakage Current			100		nA	
t <sub>of</sub> , Output Fall Time from V <sub>IHmax</sub> to V <sub>ILmax</sub>	C <sub>b</sub> bus capacitance in pf	20+0.1C <sub>b</sub>		300	ns	

INTERNAL CLOCK SOURCE						
Sample Rate	FCHOICE_B = 1,2,3 SMPLRT_DIV = 0		32		kHz	2
	FCHOICE_B = 0; DLPFCFG = 0 or 7 SMPLRT_DIV = 0		8		kHz	2
	FCHOICE_B = 0; DLPFCFG = 1,2,3,4,5,6; SMPLRT_DIV = 0		1		kHz	2
Clock Frequency Initial Tolerance	CLK_SEL = 0, 6 or gyro inactive; 25°C	-5		+5	%	1
	CLK_SEL = 1,2,3,4,5 and gyro active; 25°C	-1		+1	%	1
Frequency Variation over Temperature	CLK_SEL = 0,6 or gyro inactive	-10		+10	%	1
	CLK_SEL = 1,2,3,4,5 and gyro active	-1		+1	%	1

**Table 4. A.C. Electrical Characteristics**

**Notes:**

1. Derived from validation or characterization of parts, not guaranteed in production.
2. Guaranteed by design.

### 3.3.3 Other Electrical Specifications

Typical Operating Circuit of section 4.2, VDD = 1.8 V, VDDIO = 1.8 V, T<sub>A</sub> = 25°C, unless otherwise noted.

PARAMETER	CONDITIONS	MIN	TYP	MAX	UNITS	NOTES
<b>SERIAL INTERFACE</b>						
SPI Operating Frequency, All Registers Read/Write	Low Speed Characterization		100 ±10%		kHz	1
	High Speed Characterization		1	8	MHz	1, 2
SPI Modes			Modes 0 and 3			
I <sup>2</sup> C Operating Frequency	All registers, Fast-mode			400	kHz	1
	All registers, Standard-mode			100	kHz	1

**Table 5. Other Electrical Specifications**

**Notes:**

1. Derived from validation or characterization of parts, not guaranteed in production.
2. SPI clock duty cycle between 45% and 55% should be used for 8-MHz operation.

### 3.4 I<sup>2</sup>C TIMING CHARACTERIZATION

Typical Operating Circuit of section 4.2, VDD = 1.8 V, VDDIO = 1.8 V, T<sub>A</sub> = 25°C, unless otherwise noted.

PARAMETERS	CONDITIONS	MIN	TYP	MAX	UNITS	NOTES
<b>I<sup>2</sup>C TIMING</b>		<b>I<sup>2</sup>C FAST-MODE</b>				
f <sub>SCL</sub> , SCL Clock Frequency				400	kHz	1
t <sub>HD,STA</sub> , (Repeated) START Condition Hold Time		0.6			μs	1
t <sub>LOW</sub> , SCL Low Period		1.3			μs	1
t <sub>HIGH</sub> , SCL High Period		0.6			μs	1
t <sub>SU,STA</sub> , Repeated START Condition Setup Time		0.6			μs	1
t <sub>HD,DAT</sub> , SDA Data Hold Time		0			μs	1
t <sub>SU,DAT</sub> , SDA Data Setup Time		100			ns	1
t <sub>r</sub> , SDA and SCL Rise Time	C <sub>b</sub> bus cap. from 10 to 400 pF	20+0.1C <sub>b</sub>		300	ns	1
t <sub>f</sub> , SDA and SCL Fall Time	C <sub>b</sub> bus cap. from 10 to 400 pF	20+0.1C <sub>b</sub>		300	ns	1
t <sub>SU,STO</sub> , STOP Condition Setup Time		0.6			μs	1
t <sub>BUF</sub> , Bus Free Time Between STOP and START Condition		1.3			μs	1
C <sub>b</sub> , Capacitive Load for each Bus Line			< 400		pF	1
t <sub>VD,DAT</sub> , Data Valid Time				0.9	μs	1
t <sub>VD,ACK</sub> , Data Valid Acknowledge Time				0.9	μs	1

Table 6. I<sup>2</sup>C Timing Characteristics

**Notes:**

- Based on characterization of 5 parts over temperature and voltage as mounted on evaluation board or in sockets

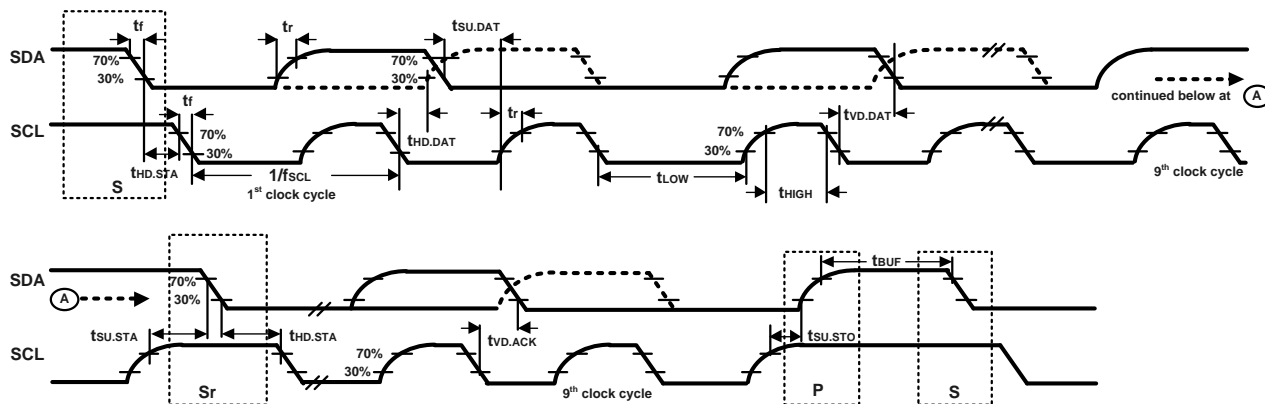

Figure 1. I<sup>2</sup>C Bus Timing Diagram

### 3.5 SPI TIMING CHARACTERIZATION

Typical Operating Circuit of section 4.2, VDD = 1.8 V, VDDIO = 1.8 V, T<sub>A</sub> = 25°C, unless otherwise noted.

PARAMETERS	CONDITIONS	MIN	TYP	MAX	UNITS	NOTES
<b>SPI TIMING</b>						
f <sub>SPC</sub> , SPC Clock Frequency				8	MHz	1
t <sub>LOW</sub> , SPC Low Period		56			ns	1
t <sub>HIGH</sub> , SPC High Period		56			ns	1
t <sub>SU,CS</sub> , CS Setup Time		2			ns	1
t <sub>HD,CS</sub> , CS Hold Time		63			ns	1
t <sub>SU,SDI</sub> , SDI Setup Time		3			ns	1
t <sub>HD,SDI</sub> , SDI Hold Time		7			ns	1
t <sub>VD,SDO</sub> , SDO Valid Time	C <sub>load</sub> = 20 pF			40	ns	1
t <sub>HD,SDO</sub> , SDO Hold Time	C <sub>load</sub> = 20 pF	6			ns	1
t <sub>DIS,SDO</sub> , SDO Output Disable Time				20	ns	1
t <sub>Fall</sub> , SPC Fall Time				6.5	ns	2
t <sub>Rise</sub> , SPC Rise Time				6.5	ns	2

**Table 7. SPI Timing Characteristics (8MHz Operation)**

**Notes:**

1. Based on characterization of 5 parts over temperature and voltage as mounted on evaluation board or in sockets
2. Based on other parameter values

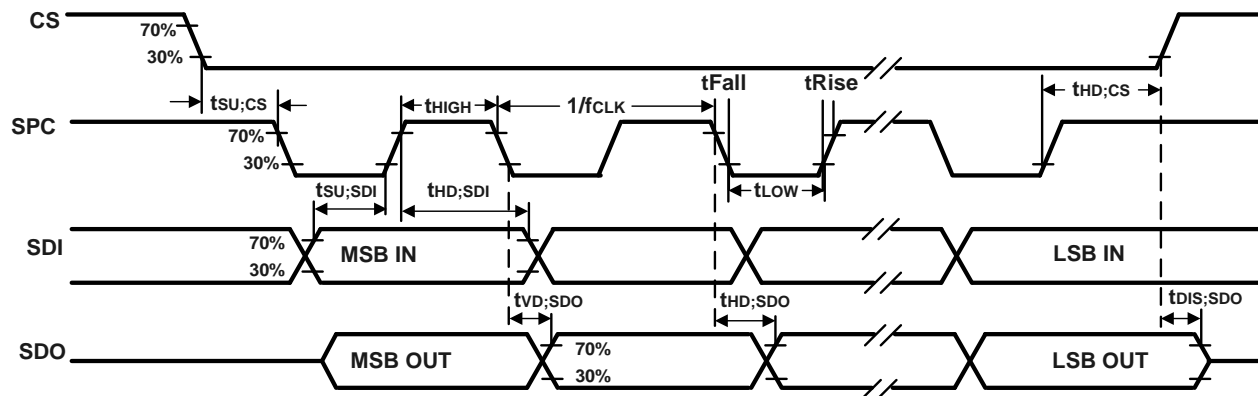

**Figure 2. SPI Bus Timing Diagram**

### 3.6 ABSOLUTE MAXIMUM RATINGS

Stress above those listed as “Absolute Maximum Ratings” may cause permanent damage to the device. These are stress ratings only and functional operation of the device at these conditions is not implied. Exposure to the absolute maximum ratings conditions for extended periods may affect device reliability.

PARAMETER	RATING
Supply Voltage, VDD	-0.5 V to +4 V
Supply Voltage, VDDIO	-0.5 V to +4 V
REGOUT	-0.5V to 2V
Input Voltage Level (SA0, FSYNC, SCL, SDA)	-0.5 V to VDD + 0.5 V
Acceleration (Any Axis, unpowered)	10,000g for 0.2 ms
Operating Temperature Range	-40°C to +85°C
Storage Temperature Range	-40°C to +125°C
Electrostatic Discharge (ESD) Protection	2 kV (HBM); 250 V (MM)
Latch-up	JEDEC Class II (2), 125°C ±100 mA

**Table 8. Absolute Maximum Ratings**

## 4 APPLICATIONS INFORMATION

### 4.1 PIN OUT DIAGRAM AND SIGNAL DESCRIPTION

PIN NUMBER	PIN NAME	PIN DESCRIPTION
8	VDDIO	Digital I/O supply voltage
9	AD0/SDO	I <sup>2</sup> C slave address LSB (AD0); SPI serial data output (SDO)
10	REGOUT	Regulator filter capacitor connection
11	FSYNC	Frame synchronization digital input. Connect to GND if unused.
12	INT	Interrupt digital output (totem pole or open-drain)
13	VDD	Power supply voltage
18	GND	Power supply ground
22	nCS	SPI chip select
23	SCL/SCLK	I <sup>2</sup> C serial clock (SCL); SPI serial clock (SCLK)
24	SDA/SDI	I <sup>2</sup> C serial data (SDA); SPI serial data input (SDI)
1, 2, 3, 4, 5, 6, 7, 14, 15, 16, 17, 19, 20, 21	NC	No Connect

**Table 9. Signal Descriptions**

Note: Power up with SCL/SCLK and nCS pins held low is not a supported use case. In case this power up approach is used, software reset is required using the PWR\_MGMT\_1 register, prior to initialization.

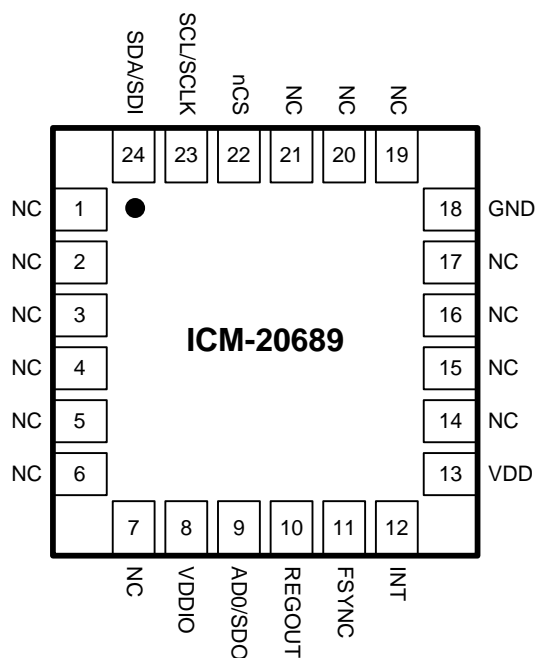

**Top View – QFN Package**  
24-pin, 4mm x 4mm x 0.9mm

**Figure 3. Pin Out Diagram for ICM-20689**

**4.2 TYPICAL OPERATING CIRCUIT**

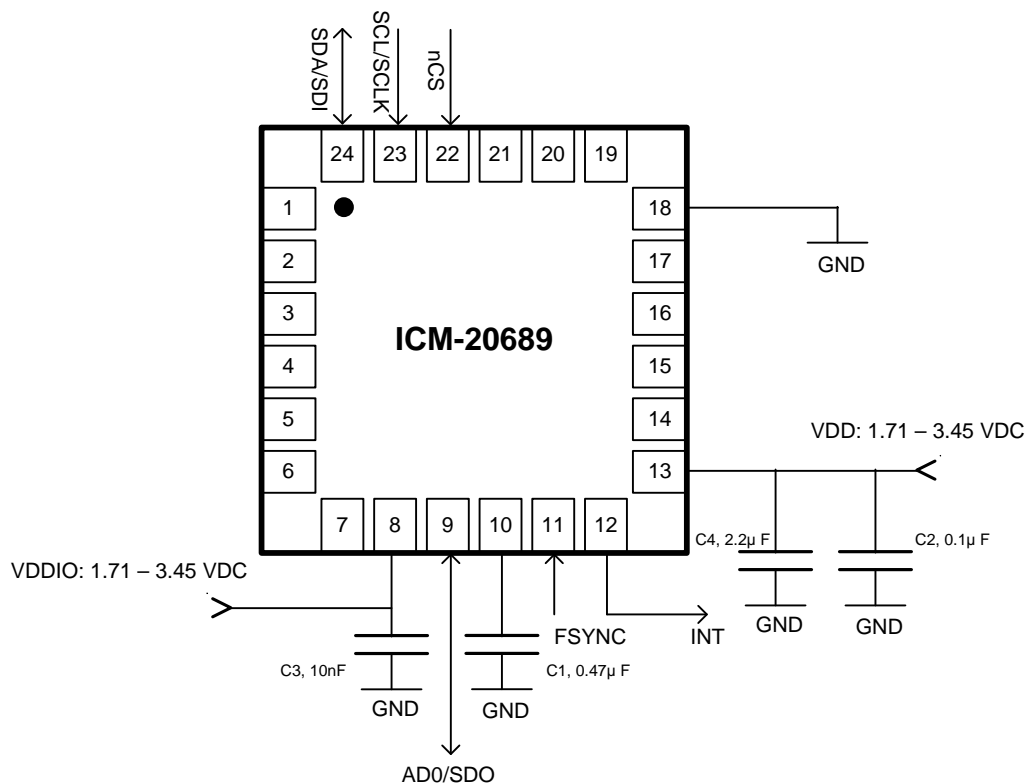

**Figure 4. ICM-20689 Application Schematic**

Note: I<sup>2</sup>C lines are open drain and pull-up resistors (e.g. 10 kΩ) are required.

**4.3 BILL OF MATERIALS FOR EXTERNAL COMPONENTS**

COMPONENT	LABEL	SPECIFICATION	QUANTITY
REGOUT Capacitor	C1	X7R, 0.47 µF ±10%	1
VDD Bypass Capacitors	C2	X7R, 0.1 µF ±10%	1
	C4	X7R, 2.2 µF ±10%	1
VDDIO Bypass Capacitor	C3	X7R, 10 nF ±10%	1

**Table 10. Bill of Materials**

#### 4.4 BLOCK DIAGRAM

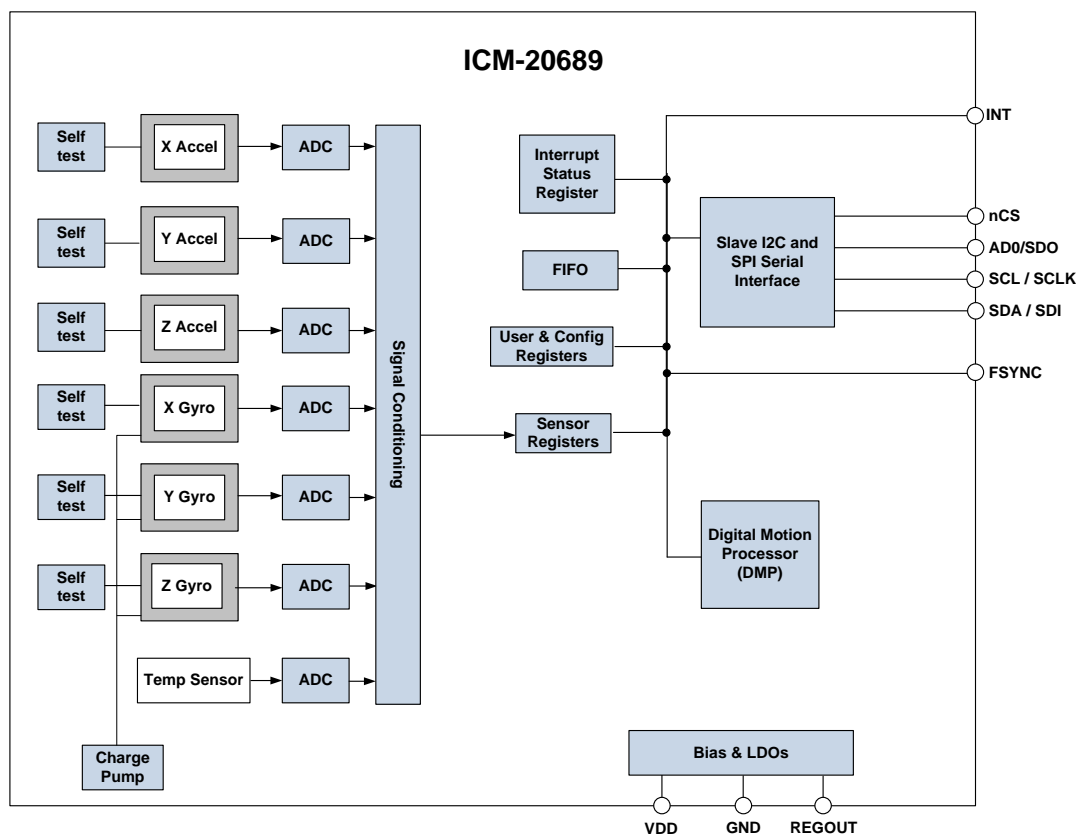

Figure 5. ICM-20689 Block Diagram

#### 4.5 OVERVIEW

The ICM-20689 is comprised of the following key blocks and functions:

- Three-axis MEMS rate gyroscope sensor with 16-bit ADCs and signal conditioning
- Three-axis MEMS accelerometer sensor with 16-bit ADCs and signal conditioning
- Digital Motion Processor (DMP) engine
- Primary I<sup>2</sup>C and SPI serial communications interfaces
- Self-Test
- Clocking
- Sensor Data Registers
- FIFO
- Interrupts
- Digital-Output Temperature Sensor
- Bias and LDOs
- Charge Pump
- Standard Power Modes

#### 4.6 THREE-AXIS MEMS GYROSCOPE WITH 16-BIT ADCS AND SIGNAL CONDITIONING

The ICM-20689 consists of three independent vibratory MEMS rate gyroscopes, which detect rotation about the X-, Y-, and Z- Axes. When the gyros are rotated about any of the sense axes, the Coriolis Effect causes a vibration that is detected by a capacitive pickoff. The resulting signal is amplified, demodulated, and filtered to produce a voltage that is proportional to the angular rate. This voltage is digitized using individual on-chip 16-bit Analog-to-Digital Converters (ADCs) to sample each axis. The full-scale range of the gyro sensors may be digitally programmed to  $\pm 250$ ,  $\pm 500$ ,  $\pm 1000$ , or  $\pm 2000$  degrees per second (dps). The ADC sample rate is programmable from 8,000 samples per second, down to 3.9 samples per second, and user-selectable low-pass filters enable a wide range of cut-off frequencies.

#### 4.7 THREE-AXIS MEMS ACCELEROMETER WITH 16-BIT ADCS AND SIGNAL CONDITIONING

The ICM-20689's 3-Axis accelerometer uses separate proof masses for each axis. Acceleration along a particular axis induces displacement on the corresponding proof mass, and capacitive sensors detect the displacement differentially. The ICM-20689's architecture reduces the accelerometers' susceptibility to fabrication variations as well as to thermal drift. When the device is placed on a flat surface, it will measure  $0g$  on the X- and Y-axes and  $+1g$  on the Z-axis. The accelerometers' scale factor is calibrated at the factory and is nominally independent of supply voltage. Each sensor has a dedicated sigma-delta ADC for providing digital outputs. The full scale range of the digital output can be adjusted to  $\pm 2g$ ,  $\pm 4g$ ,  $\pm 8g$ , or  $\pm 16g$ .

#### 4.8 DIGITAL MOTION PROCESSOR

The embedded Digital Motion Processor (DMP) offloads computation of motion processing algorithms from the host processor. The DMP acquires data from the accelerometer and gyroscope, and processes the data. The resulting data can be read from the FIFO. The DMP has access to one of the external pins, which can be used for generating interrupts.

The purpose of the DMP is to offload both timing requirements and processing power from the host processor. Typically, motion processing algorithms should be run at a high rate, often around 200Hz, in order to provide accurate results with low latency. This is required even if the application updates at a much lower rate; for example, a low power user interface may update as slowly as 5Hz, but the motion processing should still run at 200Hz. The DMP can be used to minimize power, simplify timing, simplify the software architecture, and save valuable MIPS on the host processor for use in applications.

DMP operation is possible in low-power gyroscope and low-power accelerometer modes.

#### 4.9 I<sup>2</sup>C AND SPI SERIAL COMMUNICATIONS INTERFACES

The ICM-20689 communicates to a system processor using either a SPI or an I<sup>2</sup>C serial interface. The ICM-20689 always acts as a slave when communicating to the system processor. The LSB of the I<sup>2</sup>C slave address is set by pin 4 (SA0).

##### 4.9.1 ICM-20689 Solution Using I<sup>2</sup>C Interface

In the figure below, the system processor is an I<sup>2</sup>C master to the ICM-20689.

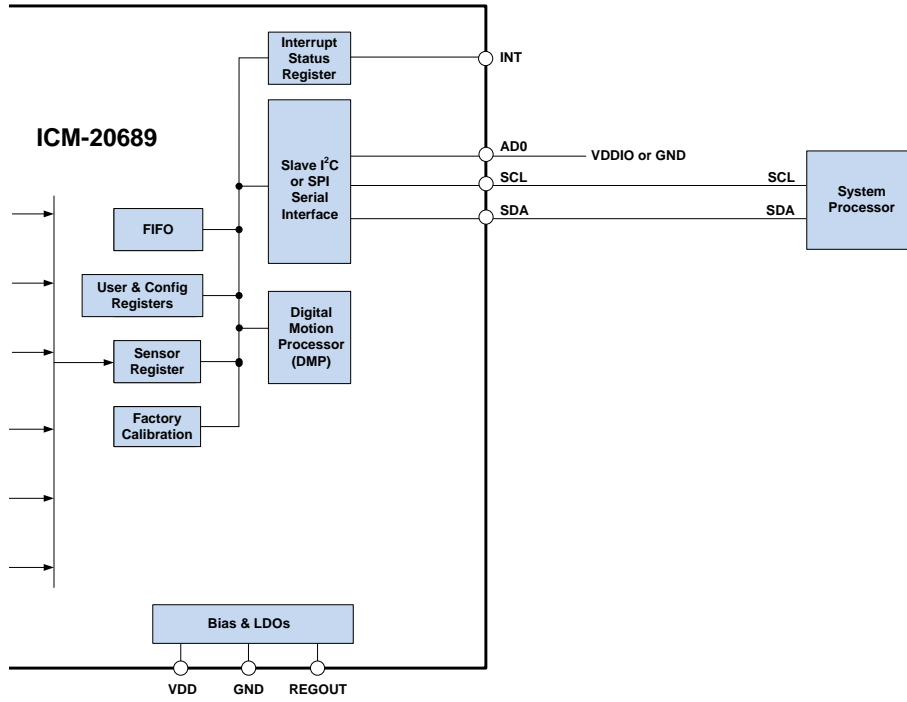

Figure 6. ICM-20689 Solution Using I<sup>2</sup>C Interface

#### 4.9.2 ICM-20689 Solution Using SPI Interface

In the figure below, the system processor is an SPI master to the ICM-20689. Pins 9, 22, 23, 24 are used to support the SDO, nCS, SCLK, and SDI signals for SPI communications.

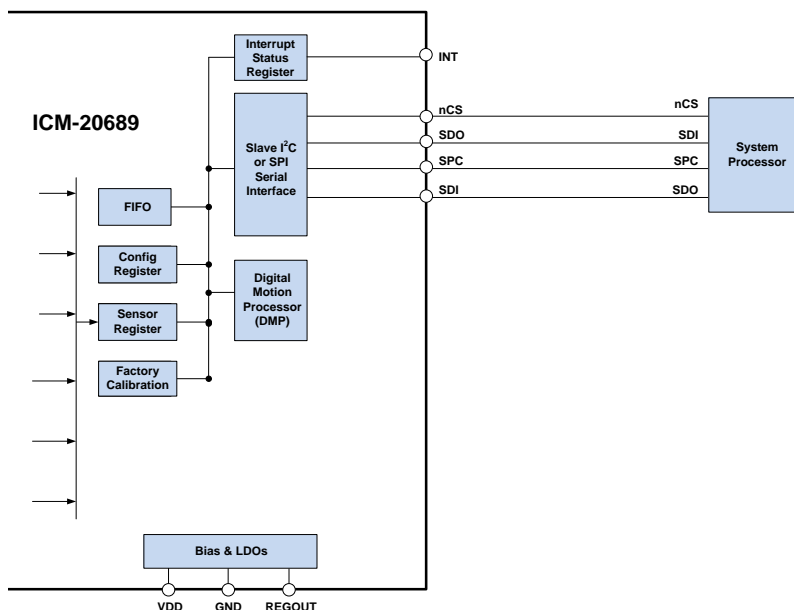

Figure 7. ICM-20689 Solution Using SPI Interface

#### 4.10 SELF-TEST

Self-test allows for the testing of the mechanical and electrical portions of the sensors. The self-test for each measurement axis can be activated by means of the gyroscope and accelerometer self-test registers (registers 27 and 28).

When the self-test is activated, the electronics cause the sensors to be actuated and produce an output signal. The output signal is used to observe the self-test response.

The self-test response is defined as follows:

$$\text{Self-test response} = \text{Sensor output with self-test enabled} - \text{Sensor output with self-test disabled}$$

When the value of the self-test response is within the specified min/max limits of the product specification, the part has passed self-test. When the self-test response exceeds the min/max values, the part is deemed to have failed self-test. It is recommended to use InvenSense MotionApps software for executing self-test.

#### 4.11 CLOCKING

The ICM-20689 has a flexible clocking scheme, allowing a variety of internal clock sources to be used for the internal synchronous circuitry. This synchronous circuitry includes the signal conditioning and ADCs, the DMP, and various control circuits and registers. An on-chip PLL provides flexibility in the allowable inputs for generating this clock.

Allowable internal sources for generating the internal clock are:

- a) An internal relaxation oscillator
- b) Auto-select between internal relaxation oscillator and gyroscope MEMS oscillator to use the best available source

The only setting supporting specified performance in all modes is option b). It is recommended that option b) be used.

#### 4.12 SENSOR DATA REGISTERS

The sensor data registers contain the latest gyroscope, accelerometer, and temperature measurement data. They are read-only registers, and are accessed via the serial interface. Data from these registers may be read anytime.

#### 4.13 FIFO

The ICM-20689 contains a 4 Kbyte FIFO register that is accessible via the Serial Interface. The FIFO configuration register determines which data is written into the FIFO. Possible choices include gyro data, accelerometer data, temperature readings, and FSYNC input. A FIFO counter keeps track of how many bytes of valid data are contained in the FIFO. The FIFO register supports burst reads. The interrupt function may be used to determine when new data is available. The ICM-20689 allows FIFO read in low-power accelerometer mode.

#### 4.14 INTERRUPTS

Interrupt functionality is configured via the Interrupt Configuration register. Items that are configurable include the INT pin configuration, the interrupt latching and clearing method, and triggers for the interrupt. Items that can trigger an interrupt are (1) Clock generator locked to new reference oscillator (used when switching clock sources); (2) new data is available to be read (from the FIFO and Data registers); (3) accelerometer event interrupts; (4) DMP; (5) FIFO overflow. The interrupt status can be read from the Interrupt Status register.

#### 4.15 DIGITAL-OUTPUT TEMPERATURE SENSOR

An on-chip temperature sensor and ADC are used to measure the ICM-20689 die temperature. The readings from the ADC can be read from the FIFO or the Sensor Data registers.

#### 4.16 BIAS AND LDOS

The bias and LDO section generates the internal supply and the reference voltages and currents required by the ICM-20689. Its two inputs are an unregulated VDD and a VDDIO logic reference supply voltage. The LDO output is bypassed by a capacitor at REGOUT. For further details on the capacitor, please refer to the Bill of Materials for External Components.

#### 4.17 CHARGE PUMP

An on-chip charge pump generates the high voltage required for the MEMS oscillator.

#### 4.18 STANDARD POWER MODES

The following table lists the user-accessible power modes for ICM-20689.

MODE	NAME	GYRO	ACCEL	DMP
1	Sleep Mode	Off	Off	Off
2	Standby Mode	Drive On	Off	Off
3	Accelerometer Low-Power Mode	Off	Duty-Cycled	On or Off
4	Accelerometer Low-Noise Mode	Off	On	On or Off
5	Gyroscope Low-Power Mode	Duty-Cycled	Off	On or Off
6	Gyroscope Low-Noise Mode	On	Off	On or Off
7	6-Axis Low-Noise Mode	On	On	On or Off
8	6-Axis Low-Power Mode	Duty-Cycled	On	On or Off

**Table 11. Standard Power Modes for ICM-20689**

**Notes:**

1. Power consumption for individual modes can be found in section 3.3.1.

## 5 PROGRAMMABLE INTERRUPTS

The ICM-20689 has a programmable interrupt system which can generate an interrupt signal on the INT pin. Status flags indicate the source of an interrupt. Interrupt sources may be enabled and disabled individually.

INTERRUPT NAME	MODULE
Motion Detection	Motion
FIFO Overflow	FIFO
Data Ready	Sensor Registers
DMP	DMP

**Table 12. Table of Interrupt Sources**

## 5.1 WAKE-ON-MOTION INTERRUPT

The ICM-20689 provides motion detection capability. A qualifying motion sample is one where the high passed sample from any axis has an absolute value exceeding a user-programmable threshold. The following steps explain how to configure the Wake-on-Motion Interrupt.

### **Step 1: Ensure that Accelerometer is running**

- In PWR\_MGMT\_1 register (0x6B) set CYCLE = 0, SLEEP = 0, and GYRO\_STANDBY = 0
- In PWR\_MGMT\_2 register (0x6C) set STBY\_XA = STBY\_YA = STBY\_ZA = 0, and STBY\_XG = STBY\_YG = STBY\_ZG = 1

### **Step 2: Accelerometer Configuration**

- In ACCEL\_CONFIG2 register (0x1D) set ACCEL\_FCHOICE\_B = 0 and A\_DLPF\_CFG[2:0] = 1 (b001)

### **Step 3: Enable Motion Interrupt**

- In INT\_ENABLE register (0x38) set WOM\_INT\_EN = 111 to enable motion interrupt

### **Step 4: Set Motion Threshold**

- Set the motion threshold in ACCEL\_WOM\_THR register (0x1F)

### **Step 5: Enable Accelerometer Hardware Intelligence**

- In ACCEL\_INTEL\_CTRL register (0x69) set ACCEL\_INTEL\_EN = ACCEL\_INTEL\_MODE = 1; Ensure that bit 0 is set to 0.

### **Step 6: Set Frequency of Wake-Up**

- In SMPLRT\_DIV register (0x19) set SMPLRT\_DIV[7:0] = 3.9 Hz – 500 Hz

### **Step 7: Enable Cycle Mode (Accelerometer Low-Power Mode)**

- In PWR\_MGMT\_1 register (0x6B) set CYCLE = 1

## 6 DIGITAL INTERFACE

### 6.1 I<sup>2</sup>C AND SPI SERIAL INTERFACES

The internal registers and memory of the ICM-20689 can be accessed using either I<sup>2</sup>C at 400 kHz or SPI at 8 MHz. SPI operates in four-wire mode.

PIN NUMBER	PIN NAME	PIN DESCRIPTION
8	VDDIO	Digital I/O supply voltage.
9	AD0 / SDO	I <sup>2</sup> C Slave Address LSB (AD0); SPI serial data output (SDO)
23	SCL / SCLK	I <sup>2</sup> C serial clock (SCL); SPI serial clock (SCLK)
24	SDA / SDI	I <sup>2</sup> C serial data (SDA); SPI serial data input (SDI)

**Table 13. Serial Interface**

**Note:**

To prevent switching into I<sup>2</sup>C mode when using SPI, the I<sup>2</sup>C interface should be disabled by setting the *I2C\_IF\_DIS* configuration bit. Setting this bit should be performed immediately after waiting for the time specified by the “Start-Up Time for Register Read/Write” in Section 6.3. For further information regarding the *I2C\_IF\_DIS* bit, please refer to sections 11 and 12 of this document.

### 6.2 I<sup>2</sup>C INTERFACE

I<sup>2</sup>C is a two-wire interface comprised of the signals serial data (SDA) and serial clock (SCL). In general, the lines are open-drain and bi-directional. In a generalized I<sup>2</sup>C interface implementation, attached devices can be a master or a slave. The master device puts the slave address on the bus, and the slave device with the matching address acknowledges the master.

The ICM-20689 always operates as a slave device when communicating to the system processor, which thus acts as the master. SDA and SCL lines typically need pull-up resistors to VDD. The maximum bus speed is 400 kHz.

The slave address of the ICM-20689 is b110100X which is 7 bits long. The LSB bit of the 7-bit address is determined by the logic level on pin SA0. This allows two ICM-20689s to be connected to the same I<sup>2</sup>C bus. When used in this configuration, the address of one of the devices should be b1101000 (pin SA0 is logic low) and the address of the other should be b1101001 (pin SA0 is logic high).

### 6.3 I<sup>2</sup>C COMMUNICATIONS PROTOCOL

*START (S) and STOP (P) Conditions*

Communication on the I<sup>2</sup>C bus starts when the master puts the START condition (S) on the bus, which is defined as a HIGH-to-LOW transition of the SDA line while SCL line is HIGH (see figure below). The bus is considered to be busy until the master puts a STOP condition (P) on the bus, which is defined as a LOW to HIGH transition on the SDA line while SCL is HIGH (see figure below).

Additionally, the bus remains busy if a repeated START (Sr) is generated instead of a STOP condition.

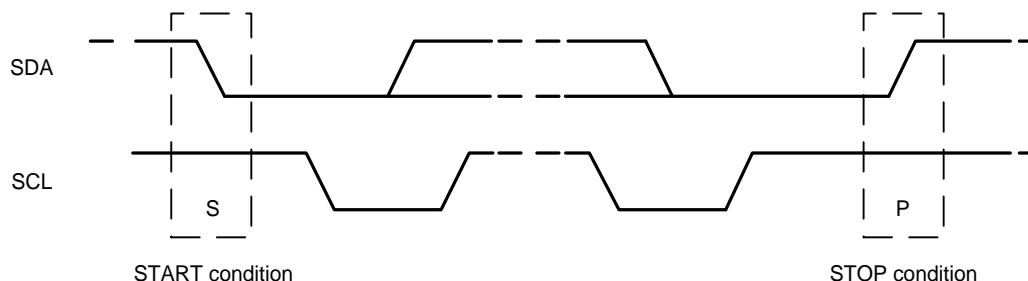
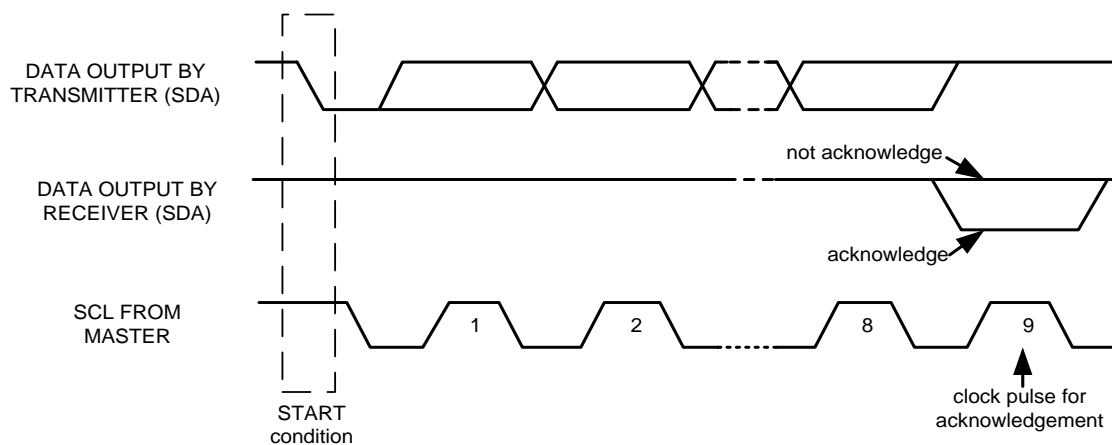

**Figure 8. START and STOP Conditions**

*Data Format / Acknowledge*

I<sup>2</sup>C data bytes are defined to be 8 bits long. There is no restriction to the number of bytes transmitted per data transfer. Each byte transferred must be followed by an acknowledge (ACK) signal. The clock for the acknowledge signal is generated by the master, while the receiver generates the actual acknowledge signal by pulling down SDA and holding it low during the HIGH portion of the acknowledge clock pulse.

If a slave is busy and cannot transmit or receive another byte of data until some other task has been performed, it can hold SCL LOW, thus forcing the master into a wait state. Normal data transfer resumes when the slave is ready, and releases the clock line (refer to the following figure).



**Figure 9. Acknowledge on the I<sup>2</sup>C Bus**

**Communications**

After beginning communications with the START condition (S), the master sends a 7-bit slave address followed by an 8<sup>th</sup> bit, the read/write bit. The read/write bit indicates whether the master is receiving data from or is writing to the slave device. Then, the master releases the SDA line and waits for the acknowledge signal (ACK) from the slave device. Each byte transferred must be followed by an acknowledge bit. To acknowledge, the slave device pulls the SDA line LOW and keeps it LOW for the high period of the SCL line. Data transmission is always terminated by the master with a STOP condition (P), thus freeing the communications line. However, the master can generate a repeated START condition (Sr), and address another slave without first generating a STOP condition (P). A LOW to HIGH transition on the SDA line while SCL is HIGH defines the stop condition. All SDA changes should take place when SCL is low, with the exception of start and stop conditions.

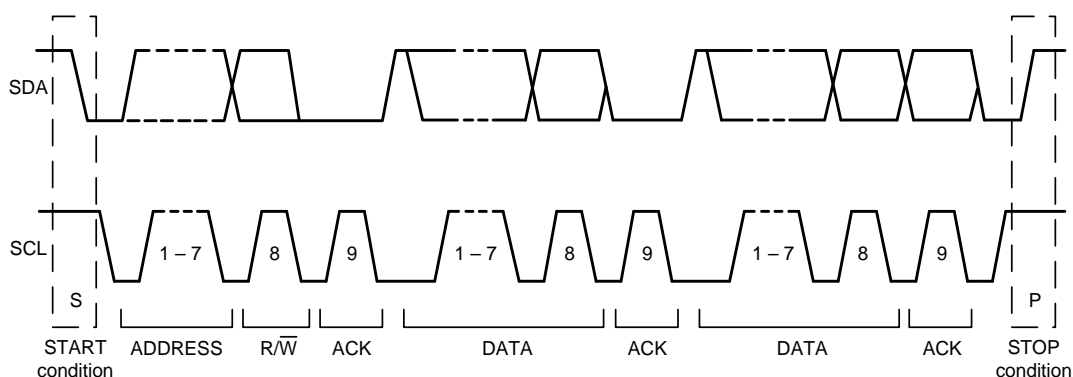

**Figure 10. Complete I<sup>2</sup>C Data Transfer**

To write the internal ICM-20689 registers, the master transmits the start condition (S), followed by the I<sup>2</sup>C address and the write bit (0). At the 9<sup>th</sup> clock cycle (when the clock is high), the ICM-20689 acknowledges the transfer. Then the master puts the register address (RA) on the bus. After the ICM-20689 acknowledges the reception of the register address, the master puts the register data onto the bus. This is followed by the ACK signal, and data transfer may be concluded by the stop condition (P). To write multiple bytes after the last ACK signal, the master can continue outputting data rather than transmitting a stop signal. In this case, the ICM-20689 automatically increments the register address and loads the data to the appropriate register. The following figures show single and two-byte write sequences.

**Single-Byte Write Sequence**

Master	S	AD+W		RA		DATA		P
Slave			ACK		ACK		ACK	

**Burst Write Sequence**

Master	S	AD+W		RA		DATA		DATA		P
Slave			ACK		ACK		ACK		ACK	

To read the internal ICM-20689 registers, the master sends a start condition, followed by the I<sup>2</sup>C address and a write bit, and then the register address that is going to be read. Upon receiving the ACK signal from the ICM-20689, the master transmits a start signal followed by the slave address and read bit. As a result, the ICM-20689 sends an ACK signal and the data. The communication ends with a not acknowledge (NACK) signal and a stop bit from master. The NACK condition is defined such that the SDA line remains high at the 9<sup>th</sup> clock cycle. The following figures show single and two-byte read sequences.

**Single-Byte Read Sequence**

Master	S	AD+W		RA		S	AD+R			NACK	P
Slave			ACK		ACK			ACK	DATA		

*Burst Read Sequence*

Master	S	AD+W		RA		S	AD+R			ACK		NACK	P
Slave			ACK		ACK			ACK	DATA		DATA		

**6.4 I<sup>2</sup>C TERMS**

SIGNAL	DESCRIPTION
S	Start Condition: SDA goes from high to low while SCL is high
AD	Slave I <sup>2</sup> C address
W	Write bit (0)
R	Read bit (1)
ACK	Acknowledge: SDA line is low while the SCL line is high at the 9 <sup>th</sup> clock cycle
NACK	Not-Acknowledge: SDA line stays high at the 9 <sup>th</sup> clock cycle
RA	ICM-20689 internal register address
DATA	Transmit or received data
P	Stop condition: SDA going from low to high while SCL is high

**Table 14. I<sup>2</sup>C Terms**

### 6.5 SPI INTERFACE

SPI is a 4-wire synchronous serial interface that uses two control lines and two data lines. The ICM-20689 always operates as a Slave device during standard Master-Slave SPI operation.

With respect to the Master, the Serial Clock output (SPC), the Serial Data Output (SDO) and the Serial Data Input (SDI) are shared among the Slave devices. Each SPI slave device requires its own Chip Select (CS) line from the master.

CS goes low (active) at the start of transmission and goes back high (inactive) at the end. Only one CS line is active at a time, ensuring that only one slave is selected at any given time. The CS lines of the non-selected slave devices are held high, causing their SDO lines to remain in a high-impedance (high-z) state so that they do not interfere with any active devices.

#### SPI Operational Features

1. Data is delivered MSB first and LSB last
2. Data is latched on the rising edge of SPC
3. Data should be transitioned on the falling edge of SPC
4. The maximum frequency of SPC is 8 MHz
5. SPI read and write operations are completed in 16 or more clock cycles (two or more bytes). The first byte contains the SPI Address, and the following byte(s) contain(s) the SPI data. The first bit of the first byte contains the Read/Write bit and indicates the Read (1) or Write (0) operation. The following 7 bits contain the Register Address. In cases of multiple-byte Read/Writes, data is two or more bytes:

#### SPI Address format

<b>MSB</b>							<b>LSB</b>
R/W	A6	A5	A4	A3	A2	A1	A0

#### SPI Data format

<b>MSB</b>							<b>LSB</b>
D7	D6	D5	D4	D3	D2	D1	D0

6. Supports Single or Burst Read/Writes.

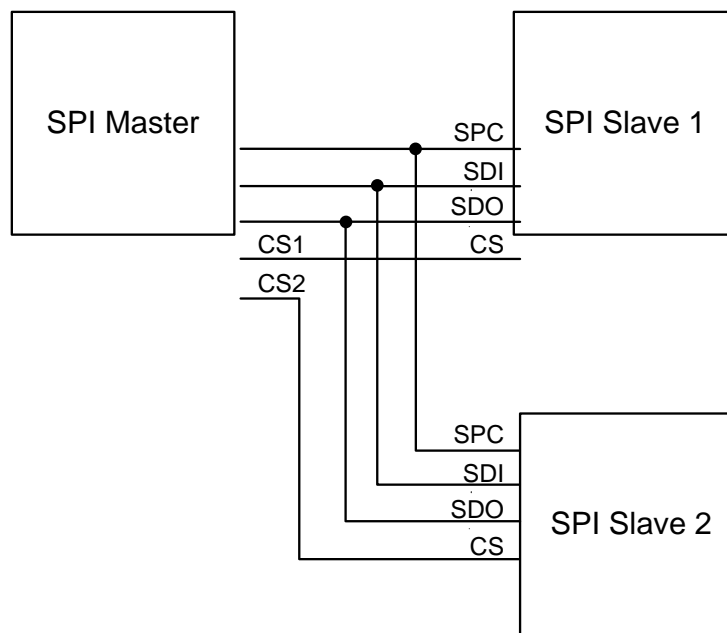

**Figure 11. Typical SPI Master/Slave Configuration**

## 7 SERIAL INTERFACE CONSIDERATIONS

### 7.1 ICM-20689 SUPPORTED INTERFACES

The ICM-20689 supports I<sup>2</sup>C communications on its serial interface.

The ICM-20689's I/O logic levels are set to be VDDIO.

The figure below depicts a sample circuit of ICM-20689. It shows the relevant logic levels and voltage connections.

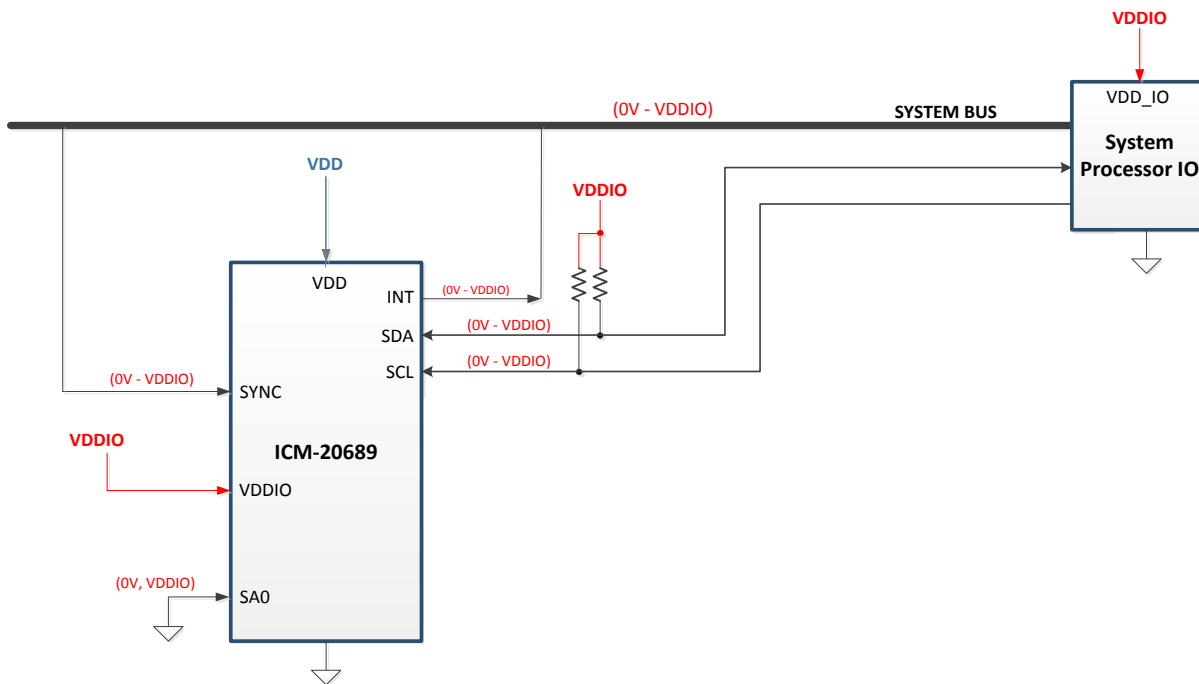

Figure 12. I/O Levels and Connections

## 8 ASSEMBLY

This section provides general guidelines for assembling InvenSense Micro Electro-Mechanical Systems (MEMS) gyros packaged in LGA package.

### 8.1 ORIENTATION OF AXES

The diagram below shows the orientation of the axes of sensitivity and the polarity of rotation. Note the pin 1 identifier (•) in the figure.

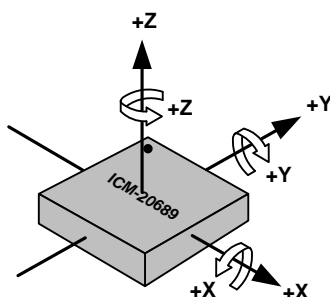

**Figure 13. Orientation of Axes of Sensitivity and Polarity of Rotation**



## 9 PART NUMBER PACKAGE MARKING

The part number package marking for ICM-20689 devices is summarized below:

PART NUMBER	PART NUMBER PACKAGE MARKING
ICM-20689	IC2689

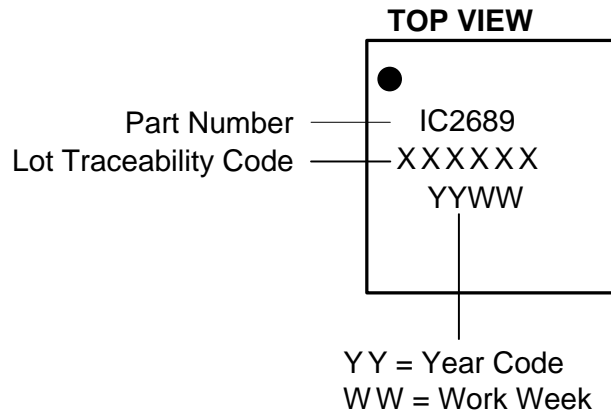

**10 REGISTER MAP**

The following table lists the register map for the ICM-20689.

Addr (Hex)	Addr (Dec.)	Register Name	Serial I/F	Accessible (writable) in Sleep Mode	Bit7	Bit6	Bit5	Bit4	Bit3	Bit2	Bit1	Bit0
00	00	SELF_TEST_X_GYRO	R/W	N	XG_ST_DATA[7:0]							
01	01	SELF_TEST_Y_GYRO	R/W	N	YG_ST_DATA[7:0]							
02	02	SELF_TEST_Z_GYRO	R/W	N	ZG_ST_DATA[7:0]							
0D	13	SELF_TEST_X_ACCEL	R/W	N	XA_ST_DATA[7:0]							
0E	14	SELF_TEST_Y_ACCEL	R/W	N	YA_ST_DATA[7:0]							
0F	15	SELF_TEST_Z_ACCEL	R/W	N	ZA_ST_DATA[7:0]							
13	19	XG_OFFS_USRH	R/W	N	X_OFFS_USR [15:8]							
14	20	XG_OFFS_USRL	R/W	N	X_OFFS_USR [7:0]							
15	21	YG_OFFS_USRH	R/W	N	Y_OFFS_USR [15:8]							
16	22	YG_OFFS_USRL	R/W	N	Y_OFFS_USR [7:0]							
17	23	ZG_OFFS_USRH	R/W	N	Z_OFFS_USR [15:8]							
18	24	ZG_OFFS_USRL	R/W	N	Z_OFFS_USR [7:0]							
19	25	SMPLRT_DIV	R/W	N	SMPLRT_DIV[7:0]							
1A	26	CONFIG	R/W	N	-	FIFO_MODE	EXT_SYNC_SET[2:0]			DLPF_CFG[2:0]		
1B	27	GYRO_CONFIG	R/W	N	XG_ST	YG_ST	ZG_ST	FS_SEL [1:0]		-	FCHOICE_B[1:0]	
1C	28	ACCEL_CONFIG	R/W	N	XA_ST	YA_ST	ZA_ST	ACCEL_FS_SEL[1:0]		-		
1D	29	ACCEL_CONFIG 2	R/W	N	-		DEC2_CFG		ACCEL_FCHOICE_B	A_DLPF_CFG		
1E	30	LP_MODE_CFG	R/W	N	GYRO_CYCLE	G_AVGCFG[2:0]			-			
1F	31	ACCEL_WOM_THR	R/W	N	WOM_THR[7:0]							
23	35	FIFO_EN	R/W	N	TEMP_FIFO_EN	XG_FIFO_EN	YG_FIFO_EN	ZG_FIFO_EN	ACCEL_FIFO_EN	-	-	-
36	54	FSYNC_INT	R/C	N	FSYNC_INT	-	-	-	-	-	-	-
37	55	INT_PIN_CFG	R/W	Y	INT_LEVEL	INT_OPEN	LATCH_INT_EN	INT_RD_CLEAR	FSYNC_INT_LEVEL	FSYNC_INT_MODE_EN	-	-
38	56	INT_ENABLE	R/W	Y	WOM_INT_EN[7:5]			FIFO_OVERFLOW_EN	-	GDRIVE_INT_EN	DMP_INT_EN	DATA_RDY_INT_EN
39	57	DMP_INT_STATUS	R/C	N	-	DMP_INT[5:0]						
3A	58	INT_STATUS	R/C	N	WOM_INT[7:5]			FIFO_OVERFLOW_INT	-	GDRIVE_INT	DMP_INT	DATA_RDY_INT
3B	59	ACCEL_XOUT_H	R	N	ACCEL_XOUT_H[15:8]							
3C	60	ACCEL_XOUT_L	R	N	ACCEL_XOUT_L[7:0]							
3D	61	ACCEL_YOUT_H	R	N	ACCEL_YOUT_H[15:8]							
3E	62	ACCEL_YOUT_L	R	N	ACCEL_YOUT_L[7:0]							
3F	63	ACCEL_ZOUT_H	R	N	ACCEL_ZOUT_H[15:8]							
40	64	ACCEL_ZOUT_L	R	N	ACCEL_ZOUT_L[7:0]							
41	65	TEMP_OUT_H	R	N	TEMP_OUT[15:8]							
42	66	TEMP_OUT_L	R	N	TEMP_OUT[7:0]							
43	67	GYRO_XOUT_H	R	N	GYRO_XOUT[15:8]							
44	68	GYRO_XOUT_L	R	N	GYRO_XOUT[7:0]							
45	69	GYRO_YOUT_H	R	N	GYRO_YOUT[15:8]							
46	70	GYRO_YOUT_L	R	N	GYRO_YOUT[7:0]							
47	71	GYRO_ZOUT_H	R	N	GYRO_ZOUT[15:8]							
48	72	GYRO_ZOUT_L	R	N	GYRO_ZOUT[7:0]							
68	104	SIGNAL_PATH_RESET	R/W	N	-	-	-	-	-	-	ACCEL_RST	TEMP_RST
69	105	ACCEL_INTEL_CTRL	R/W	N	ACCEL_INTEL_EN	ACCEL_INTEL_MODE	-					

Addr (Hex)	Addr (Dec.)	Register Name	Serial I/F	Accessible (writable) in Sleep Mode	Bit7	Bit6	Bit5	Bit4	Bit3	Bit2	Bit1	Bit0	
6A	106	USER_CTRL	R/W	N	DMP_EN	FIFO_EN	-	I2C_IF_DIS	DMP_RST	FIFO_RST	-	SIG_COND_RST	
6B	107	PWR_MGMT_1	R/W	Y	DEVICE_RESET	SLEEP	ACCEL_CYCLE	GYRO_STANDBY	TEMP_DIS	CLKSEL[2:0]			
6C	108	PWR_MGMT_2	R/W	Y	FIFO_LP_EN	DMP_LP_DIS	STBY_XA	STBY_YA	STBY_ZA	STBY_XG	STBY_YG	STBY_ZG	
72	114	FIFO_COUNTH	R	N	-			FIFO_COUNT[12:8]					
73	115	FIFO_COUNTL	R	N	FIFO_COUNT[7:0]								
74	116	FIFO_R_W	R/W	N	FIFO_DATA[7:0]								
75	117	WHO_AM_I	R	N	WHOAMI[7:0]								
77	119	XA_OFFSET_H	R/W	N	XA_OFFS [14:7]								
78	120	XA_OFFSET_L	R/W	N	XA_OFFS [6:0]							-	
7A	122	YA_OFFSET_H	R/W	N	YA_OFFS [14:7]								
7B	123	YA_OFFSET_L	R/W	N	YA_OFFS [6:0]							-	
7D	125	ZA_OFFSET_H	R/W	N	ZA_OFFS [14:7]								
7E	126	ZA_OFFSET_L	R/W	N	ZA_OFFS [6:0]							-	

**Note:** Register Names ending in *\_H* and *\_L* contain the high and low bytes, respectively, of an internal register value.

In the detailed register tables that follow, register names are in capital letters, while register values are in capital letters and italicized. For example, the *ACCEL\_XOUT\_H* register (Register 59) contains the 8 most significant bits, *ACCEL\_XOUT[15:8]*, of the 16-bit X-Axis accelerometer measurement, *ACCEL\_XOUT*.

The reset value is 0x00 for all registers other than the registers below, also the self-test registers contain pre-programmed values and will not be 0x00 after reset.

- Register 107 (0x40) Power Management 1
- Register 117 (0x98) WHO\_AM\_I

## 11 REGISTER DESCRIPTIONS

This section describes the function and contents of each register within the ICM-20689.

Note: The device will come up in sleep mode upon power-up.

### 11.1 REGISTERS 0 TO 2 – GYROSCOPE SELF-TEST REGISTERS

**Register Name:** SELF\_TEST\_X\_GYRO, SELF\_TEST\_Y\_GYRO, SELF\_TEST\_Z\_GYRO

**Type:** READ/WRITE

**Register Address:** 00, 01, 02 (Decimal); 00, 01, 02 (Hex)

REGISTER	BIT	NAME	FUNCTION
SELF_TEST_X_GYRO	[7:0]	XG_ST_DATA[7:0]	The value in this register indicates the self-test output generated during manufacturing tests. This value is to be used to check against subsequent self-test outputs performed by the end user.
SELF_TEST_Y_GYRO	[7:0]	YG_ST_DATA[7:0]	The value in this register indicates the self-test output generated during manufacturing tests. This value is to be used to check against subsequent self-test outputs performed by the end user.
SELF_TEST_Z_GYRO	[7:0]	ZG_ST_DATA[7:0]	The value in this register indicates the self-test output generated during manufacturing tests. This value is to be used to check against subsequent self-test outputs performed by the end user.

The equation to convert self-test codes in OTP to factory self-test measurement is:

$$ST\_OTP = (2620/2^{FS}) * 1.01^{(ST\_code-1)} \text{ (lsb)}$$

where ST\_OTP is the value that is stored in OTP of the device, FS is the Full Scale value, and ST\_code is based on the Self-Test value (ST\_FAC) determined in InvenSense’s factory final test and calculated based on the following equation:

$$ST\_code = round\left(\frac{\log(ST\_FAC / (2620/2^{FS}))}{\log(1.01)}\right) + 1$$

### 11.2 REGISTERS 13 TO 15 – ACCELEROMETER SELF-TEST REGISTERS

**Register Name:** SELF\_TEST\_X\_ACCEL, SELF\_TEST\_Y\_ACCEL, SELF\_TEST\_Z\_ACCEL

**Type:** READ/WRITE

**Register Address:** 13, 14, 15 (Decimal); 0D, 0E, 0F (Hex)

REGISTER	BITS	NAME	FUNCTION
SELF_TEST_X_ACCEL	[7:0]	XA_ST_DATA[7:0]	The value in this register indicates the self-test output generated during manufacturing tests. This value is to be used to check against subsequent self-test outputs performed by the end user.
SELF_TEST_Y_ACCEL	[7:0]	YA_ST_DATA[7:0]	The value in this register indicates the self-test output generated during manufacturing tests. This value is to be used to check against subsequent self-test outputs performed by the end user.
SELF_TEST_Z_ACCEL	[7:0]	ZA_ST_DATA[7:0]	The value in this register indicates the self-test output generated during manufacturing tests. This value is to be used to check against subsequent self-test outputs performed by the end user.

The equation to convert self-test codes in OTP to factory self-test measurement is:

$$ST\_OTP = (2620 / 2^{FS}) * 1.01^{(ST\_code-1)} \text{ (1sb)}$$

where ST\_OTP is the value that is stored in OTP of the device, FS is the Full Scale value, and ST\_code is based on the Self-Test value (ST\_FAC) determined in InvenSense’s factory final test and calculated based on the following equation:

$$ST\_code = round\left(\frac{\log(ST\_FAC / (2620 / 2^{FS}))}{\log(1.01)}\right) + 1$$

### 11.3 REGISTER 19 – GYRO OFFSET ADJUSTMENT REGISTER

**Register Name:** XG\_OFFS\_USRH  
**Register Type:** READ/WRITE  
**Register Address:** 19 (Decimal); 13 (Hex)

BIT	NAME	FUNCTION
[7:0]	X_OFFS_USR[15:8]	Bits 15 to 8 of the 16-bit offset of X gyroscope (2’s complement). This register is used to remove DC bias from the sensor output. The value in this register is added to the gyroscope sensor value before going into the sensor register.

### 11.4 REGISTER 20 – GYRO OFFSET ADJUSTMENT REGISTER

**Register Name:** XG\_OFFS\_USRL  
**Register Type:** READ/WRITE  
**Register Address:** 20 (Decimal); 14 (Hex)

BIT	NAME	FUNCTION
[7:0]	X_OFFS_USR[7:0]	Bits 7 to 0 of the 16-bit offset of X gyroscope (2’s complement). This register is used to remove DC bias from the sensor output. The value in this register is added to the gyroscope sensor value before going into the sensor register.

### 11.5 REGISTER 21 – GYRO OFFSET ADJUSTMENT REGISTER

**Register Name:** YG\_OFFS\_USRH  
**Register Type:** READ/WRITE  
**Register Address:** 21 (Decimal); 15 (Hex)

BIT	NAME	FUNCTION
[7:0]	Y_OFFS_USR[15:8]	Bits 15 to 8 of the 16-bit offset of Y gyroscope (2’s complement). This register is used to remove DC bias from the sensor output. The value in this register is added to the gyroscope sensor value before going into the sensor register.

### 11.6 REGISTER 22 – GYRO OFFSET ADJUSTMENT REGISTER

**Register Name:** YG\_OFFS\_USRL  
**Register Type:** READ/WRITE  
**Register Address:** 22 (Decimal); 16 (Hex)

BIT	NAME	FUNCTION
[7:0]	Y_OFFS_USR[7:0]	Bits 7 to 0 of the 16-bit offset of Y gyroscope (2's complement). This register is used to remove DC bias from the sensor output. The value in this register is added to the gyroscope sensor value before going into the sensor register.

### 11.7 REGISTER 23 – GYRO OFFSET ADJUSTMENT REGISTER

**Register Name:** ZG\_OFFS\_USRH  
**Register Type:** READ/WRITE  
**Register Address:** 23 (Decimal); 17 (Hex)

BIT	NAME	FUNCTION
[7:0]	Z_OFFS_USR[15:8]	Bits 15 to 8 of the 16-bit offset of Z gyroscope (2's complement). This register is used to remove DC bias from the sensor output. The value in this register is added to the gyroscope sensor value before going into the sensor register.

### 11.8 REGISTER 24 – GYRO OFFSET ADJUSTMENT REGISTER

**Register Name:** ZG\_OFFS\_USRL  
**Register Type:** READ/WRITE  
**Register Address:** 24 (Decimal); 18 (Hex)

BIT	NAME	FUNCTION
[7:0]	Z_OFFS_USR[7:0]	Bits 7 to 0 of the 16-bit offset of Z gyroscope (2's complement). This register is used to remove DC bias from the sensor output. The value in this register is added to the gyroscope sensor value before going into the sensor register.

### 11.9 REGISTER 25 – SAMPLE RATE DIVIDER

**Register Name:** SMPLRT\_DIV  
**Register Type:** READ/WRITE  
**Register Address:** 25 (Decimal); 19 (Hex)

BIT	NAME	FUNCTION
[7:0]	SMPLRT_DIV[7:0]	Divides the internal sample rate (see register CONFIG) to generate the sample rate that controls sensor data output rate, FIFO sample rate. NOTE: This register is only effective when FCHOICE_B register bits are 2'b00, and (0 < DLPF_CFG < 7). This is the update rate of the sensor register: $\text{SAMPLE\_RATE} = \text{INTERNAL\_SAMPLE\_RATE} / (1 + \text{SMPLRT\_DIV})$ Where INTERNAL_SAMPLE_RATE = 1kHz

**11.10 REGISTER 26 – CONFIGURATION**

**Register Name:** CONFIG  
**Register Type:** READ/WRITE  
**Register Address:** 26 (Decimal); 1A (Hex)

BIT	NAME	FUNCTION																		
[7]	-	Always set to 0																		
[6]	FIFO_MODE	When set to '1', when the FIFO is full, additional writes will not be written to FIFO. When set to '0', when the FIFO is full, additional writes will be written to the FIFO, replacing the oldest data.																		
[5:3]	EXT_SYNC_SET[2:0]	Enables the FSYNC pin data to be sampled.  <table border="1" style="margin-left: auto; margin-right: auto;"> <thead> <tr> <th>EXT_SYNC_SET</th> <th>FSYNC bit location</th> </tr> </thead> <tbody> <tr><td>0</td><td>function disabled</td></tr> <tr><td>1</td><td>TEMP_OUT_L[0]</td></tr> <tr><td>2</td><td>GYRO_XOUT_L[0]</td></tr> <tr><td>3</td><td>GYRO_YOUT_L[0]</td></tr> <tr><td>4</td><td>GYRO_ZOUT_L[0]</td></tr> <tr><td>5</td><td>ACCEL_XOUT_L[0]</td></tr> <tr><td>6</td><td>ACCEL_YOUT_L[0]</td></tr> <tr><td>7</td><td>ACCEL_ZOUT_L[0]</td></tr> </tbody> </table> <p>FSYNC will be latched to capture short strobes. This will be done such that if FSYNC toggles, the latched value toggles, but won't toggle again until the new latched value is captured by the sample rate strobe.</p>	EXT_SYNC_SET	FSYNC bit location	0	function disabled	1	TEMP_OUT_L[0]	2	GYRO_XOUT_L[0]	3	GYRO_YOUT_L[0]	4	GYRO_ZOUT_L[0]	5	ACCEL_XOUT_L[0]	6	ACCEL_YOUT_L[0]	7	ACCEL_ZOUT_L[0]
EXT_SYNC_SET	FSYNC bit location																			
0	function disabled																			
1	TEMP_OUT_L[0]																			
2	GYRO_XOUT_L[0]																			
3	GYRO_YOUT_L[0]																			
4	GYRO_ZOUT_L[0]																			
5	ACCEL_XOUT_L[0]																			
6	ACCEL_YOUT_L[0]																			
7	ACCEL_ZOUT_L[0]																			
[2:0]	DLPF_CFG[2:0]	For the DLPF to be used, FCHOICE_B[1:0] is 2'b00. See the table below.																		

The DLPF is configured by *DLPF\_CFG*, when *FCHOICE\_B* [1:0] = 2b'00. The gyroscope and temperature sensor are filtered according to the value of *DLPF\_CFG* and *FCHOICE\_B* as shown in the table below.

FCHOICE_B		DLPF_CFG	Gyroscope			Temperature Sensor
<1>	<0>		3-dB BW (Hz)	Noise BW (Hz)	Rate (kHz)	3-dB BW (Hz)
X	1	X	8173	8595.1	32	4000
1	0	X	3281	3451.0	32	4000
0	0	0	250	306.6	8	4000
0	0	1	176	177.0	1	188
0	0	2	92	108.6	1	98
0	0	3	41	59.0	1	42
0	0	4	20	30.5	1	20
0	0	5	10	15.6	1	10
0	0	6	5	8.0	1	5
0	0	7	3281	3451.0	8	4000

### 11.11 REGISTER 27 – GYROSCOPE CONFIGURATION

**Register Name:** GYRO\_CONFIG  
**Register Type:** READ/WRITE  
**Register Address:** 27 (Decimal); 1B (Hex)

BIT	NAME	FUNCTION
[7]	XG_ST	X Gyro self-test
[6]	YG_ST	Y Gyro self-test
[5]	ZG_ST	Z Gyro self-test
[4:3]	FS_SEL[1:0]	Gyro Full Scale Select: 00 = ±250dps 01 = ±500dps 10 = ±1000dps 11 = ±2000dps
[2]	-	Reserved
[1:0]	FCHOICE_B[1:0]	Used to bypass DLPF as shown in the table above.

### 11.12 REGISTER 28 – ACCELEROMETER CONFIGURATION

**Register Name:** ACCEL\_CONFIG  
**Register Type:** READ/WRITE  
**Register Address:** 28 (Decimal); 1C (Hex)

BIT	NAME	FUNCTION
[7]	XA_ST	X Accel self-test
[6]	YA_ST	Y Accel self-test
[5]	ZA_ST	Z Accel self-test
[4:3]	ACCEL_FS_SEL[1:0]	Accel Full Scale Select: ±2g (00), ±4g (01), ±8g (10), ±16g (11)
[2:0]	-	Reserved

### 11.13 REGISTER 29 – ACCELEROMETER CONFIGURATION 2

**Register Name:** ACCEL\_CONFIG2  
**Register Type:** READ/WRITE  
**Register Address:** 29 (Decimal); 1D (Hex)

BIT	NAME	FUNCTION
[7:6]	-	Reserved
[5:4]	DEC2_CFG[1:0]	Averaging filter settings for Low Power Accelerometer mode: 0 = Average 4 samples 1 = Average 8 samples 2 = Average 16 samples 3 = Average 32 samples
[3]	ACCEL_FCHOICE_B	Used to bypass DLPF as shown in the table below.
[2:0]	A_DLPF_CFG	Accelerometer low pass filter setting as shown in the table below.

**Accelerometer Data Rates and Bandwidths (Low-Noise Mode)**

ACCEL_FCHOICE_B	A_DLPF_CFG	Accelerometer		
		3-dB BW (Hz)	Noise BW (Hz)	Rate (kHz)
1	X	1046.0	1100.0	4
0	0	218.1	235.0	1
0	1	218.1	235.0	1
0	2	99.0	121.3	1
0	3	44.8	61.5	1
0	4	21.2	31.0	1
0	5	10.2	15.5	1
0	6	5.1	7.8	1
0	7	420.0	441.6	1

The data output rate of the DLPF filter block can be further reduced by a factor of  $1/(1+SMPLRT\_DIV)$ , where SMPLRT\_DIV is an 8-bit integer. Following is a small subset of ODRs that are configurable for the accelerometer in the low-noise mode in this manner (Hz): 3.91, 7.81, 15.63, 31.25, 62.50, 125, 250, 500, 1K.

The following table lists the accelerometer filter bandwidths, noise, and current consumption available in the low-power mode of operation. In the low-power mode of operation, the accelerometer is duty-cycled.

ACCEL_FCHOICE_B	1	0	0	0	0
A_DLPF_CFG	x	7	7	7	7
DEC2_CFG	x	0	1	2	3
Averages	1x	4x	8x	16x	32x
Ton (ms)	1.084	1.84	2.84	4.84	8.84
Noise BW (Hz)	1100.0	441.6	235.4	121.3	61.5
Noise (mg) TYP based on $250\mu\text{g}/\sqrt{\text{Hz}}$	8.3	5.3	3.8	2.8	2.0
SMPLRT_DIV	ODR (Hz)	Current Consumption ( $\mu\text{A}$ ) TYP			
255	3.9	8.4	9.4	10.8	13.6
127	7.8	9.8	11.9	14.7	20.3
63	15.6	12.8	17.0	22.5	33.7
31	31.3	18.7	27.1	38.2	60.4
15	62.5	30.4	47.2	69.4	113.9
7	125.0	57.4	87.5	132.0	220.9
3	250.0	100.9	168.1	257.0	N/A
1	500.0	194.9	329.3	N/A	

**11.14 REGISTER 30 – LOW POWER MODE CONFIGURATION**

**Register Name:** LP\_MODE\_CFG  
**Register Type:** READ/WRITE  
**Register Address:** 30 (Decimal); 1E (Hex)

BIT	NAME	FUNCTION
[7]	GYRO_CYCLE	When set to '1' low-power gyroscope mode is enabled. Default setting is '0'
[6:4]	G_AVGCFG[2:0]	Averaging filter configuration for low-power gyroscope mode. Default setting is '000'
[3:0]	-	Reserved

To operate in gyroscope low-power mode or 6-axis low-power mode, GYRO\_CYCLE should be set to '1.' Gyroscope filter configuration is determined by G\_AVGCFG[2:0] that sets the averaging filter configuration. It is not dependent on DLPF\_CFG[2:0]. The following table shows some example configurations for gyroscope low power mode.

FCHOICE_B	0	0	0	0	0	0	0	0	0
G_AVGCFG	0	1	2	3	4	5	6	7	
Averages	1x	2x	4x	8x	16x	32x	64x	128x	
Ton (ms)	1.73	2.23	3.23	5.23	9.23	17.23	33.23	65.23	
Noise BW (Hz)	650.8	407.1	224.2	117.4	60.2	30.6	15.6	8.0	
Noise (dps) TYP based on 0.008°/s/√Hz	0.20	0.16	0.12	0.09	0.06	0.04	0.03	0.02	
SMPLRT_DIV	ODR (Hz)	Current Consumption (mA) TYP							
255	3.9	1.3	1.3	1.3	1.3	1.4	1.4	1.5	1.8
99	10.0	1.3	1.3	1.4	1.4	1.5	1.6	1.9	2.5
64	15.4	1.4	1.4	1.4	1.5	1.6	1.8	2.2	N/A
32	30.3	1.4	1.4	1.5	1.6	1.8	2.2	N/A	
19	50.0	1.5	1.5	1.6	1.8	2.1	2.8	N/A	
9	100.0	1.6	1.7	1.9	2.2	3.0	N/A		
7	125.0	1.7	1.8	2.0	2.5	N/A			
4	200.0	1.9	2.1	2.5	N/A				
3	250.0	2.1	2.3	2.7	N/A				
2	333.3	2.3	2.6	N/A					
1	500.0	2.9	N/A						

**11.15 REGISTER 31 – WAKE-ON MOTION THRESHOLD (ACCELEROMETER)**

**Register Name:** ACCEL\_WOM\_THR  
**Register Type:** READ/WRITE  
**Register Address:** 31 (Decimal); 1F (Hex)

BIT	NAME	FUNCTION
[7:0]	WOM_THR[7:0]	This register holds the threshold value for the Wake on Motion Interrupt for accelerometer.

**11.16 REGISTER 35 – FIFO ENABLE**

**Register Name:** FIFO\_EN  
**Register Type:** READ/WRITE  
**Register Address:** 35 (Decimal); 23 (Hex)

BIT	NAME	FUNCTION
[7]	TEMP_FIFO_EN	1 – Write TEMP_OUT_H and TEMP_OUT_L to the FIFO at the sample rate; If enabled, buffering of data occurs even if data path is in standby. 0 – Function is disabled
[6]	XG_FIFO_EN	1 – Write GYRO_XOUT_H and GYRO_XOUT_L to the FIFO at the sample rate; If enabled, buffering of data occurs even if data path is in standby. 0 – Function is disabled
[5]	YG_FIFO_EN	1 – Write GYRO_YOUT_H and GYRO_YOUT_L to the FIFO at the sample rate; If enabled, buffering of data occurs even if data path is in standby. 0 – Function is disabled NOTE: Enabling any one of the bits corresponding to the Gyros or Temp data paths, data is buffered into the FIFO even though that data path is not enabled.
[4]	ZG_FIFO_EN	1 – Write GYRO_ZOUT_H and GYRO_ZOUT_L to the FIFO at the sample rate; If enabled, buffering of data occurs even if data path is in standby. 0 – Function is disabled
[3]	ACCEL_FIFO_EN	1 – Write ACCEL_XOUT_H, ACCEL_XOUT_L, ACCEL_YOUT_H, ACCEL_YOUT_L, ACCEL_ZOUT_H, and ACCEL_ZOUT_L to the FIFO at the sample rate; 0 – Function is disabled
[2:0]	-	Reserved

**11.17 REGISTER 54 – FSYNC INTERRUPT STATUS**

**Register Name:** FSYNC\_INT  
**Register Type:** READ to CLEAR  
**Register Address:** 54 (Decimal); 36 (Hex)

BIT	NAME	FUNCTION
[7]	FSYNC_INT	This bit automatically sets to 1 when a FSYNC interrupt has been generated. The bit clears to 0 after the register has been read.

### 11.18 REGISTER 55 – INT/DRDY PIN / BYPASS ENABLE CONFIGURATION

**Register Name:** INT\_PIN\_CFG  
**Register Type:** READ/WRITE  
**Register Address:** 55 (Decimal); 37 (Hex)

BIT	NAME	FUNCTION
[7]	INT_LEVEL	1 – The logic level for INT/DRDY pin is active low. 0 – The logic level for INT/DRDY pin is active high.
[6]	INT_OPEN	1 – INT/DRDY pin is configured as open drain. 0 – INT/DRDY pin is configured as push-pull.
[5]	LATCH_INT_EN	1 – INT/DRDY pin level held until interrupt status is cleared. 0 – INT/DRDY pin indicates interrupt pulse's width is 50us.
[4]	INT_RD_CLEAR	1 – Interrupt status is cleared if any read operation is performed. 0 – Interrupt status is cleared only by reading INT_STATUS register
[3]	FSYNC_INT_LEVEL	1 – The logic level for the FSYNC pin as an interrupt is active low. 0 – The logic level for the FSYNC pin as an interrupt is active high.
[2]	FSYNC_INT_MODE_EN	1 – The FSYNC pin will trigger an interrupt when it transitions to the level specified by FSYNC_INT_LEVEL. 0 – The FSYNC pin is disabled from causing an interrupt.
[1]	-	Reserved
[0]	-	Always set to 0

### 11.19 REGISTER 56 – INTERRUPT ENABLE

**Register Name:** INT\_ENABLE  
**Register Type:** READ/WRITE  
**Register Address:** 56 (Decimal); 38 (Hex)

BIT	NAME	FUNCTION
[7:5]	WOM_INT_EN[7:5]	111 – Enable WoM interrupt on accelerometer. 000 – Disable WoM interrupt on accelerometer.
[4]	FIFO_OFLOW_EN	1 – Enables a FIFO buffer overflow to generate an interrupt. 0 – Function is disabled.
[3]	-	Reserved
[2]	GDRIVE_INT_EN	Gyroscope Drive System Ready interrupt enable
[1]	DMP_INT_EN	DMP interrupt enable
[0]	DATA_RDY_INT_EN	Data ready interrupt enable

### 11.20 REGISTER 57 – DMP INTERRUPT STATUS

**Register Name:** DMP\_INT\_STATUS  
**Register Type:** READ to CLEAR  
**Register Address:** 57 (Decimal); 39 (Hex)

BIT	NAME	FUNCTION
[7:6]	-	Reserved
[5:0]	DMP_INT	DMP interrupts

**11.21 REGISTER 58 – INTERRUPT STATUS**

**Register Name:** INT\_STATUS  
**Register Type:** READ to CLEAR  
**Register Address:** 58 (Decimal); 3A (Hex)

BIT	NAME	FUNCTION
[7:5]	WOM_INT	Accelerometer WoM interrupt status. Cleared on Read. 111 – WoM interrupt on accelerometer
[4]	FIFO_OFLOW_INT	This bit automatically sets to 1 when a FIFO buffer overflow has been generated. The bit clears to 0 after the register has been read.
[3]	-	Reserved.
[2]	GDRIVE_INT	Gyroscope Drive System Ready interrupt
[1]	DMP_INT	DMP interrupt
[0]	DATA_RDY_INT	This bit automatically sets to 1 when a Data Ready interrupt is generated. The bit clears to 0 after the register has been read.

**11.22 REGISTERS 59 TO 64 – ACCELEROMETER MEASUREMENTS**

**Register Name:** ACCEL\_XOUT\_H  
**Register Type:** READ only  
**Register Address:** 59 (Decimal); 3B (Hex)

BIT	NAME	FUNCTION
[7:0]	ACCEL_XOUT_H[15:8]	High byte of accelerometer x-axis data.

**Register Name:** ACCEL\_XOUT\_L  
**Register Type:** READ only  
**Register Address:** 60 (Decimal); 3C (Hex)

BIT	NAME	FUNCTION
[7:0]	ACCEL_XOUT_L[7:0]	Low byte of accelerometer x-axis data.

**Register Name:** ACCEL\_YOUT\_H  
**Register Type:** READ only  
**Register Address:** 61 (Decimal); 3D (Hex)

BIT	NAME	FUNCTION
[7:0]	ACCEL_YOUT_H[15:8]	High byte of accelerometer y-axis data.

**Register Name:** ACCEL\_YOUT\_L  
**Register Type:** READ only  
**Register Address:** 62 (Decimal); 3E (Hex)

BIT	NAME	FUNCTION
[7:0]	ACCEL_YOUT_L[7:0]	Low byte of accelerometer y-axis data.

**Register Name:** ACCEL\_ZOUT\_H  
**Register Type:** READ only  
**Register Address:** 63 (Decimal); 3F (Hex)

BIT	NAME	FUNCTION
[7:0]	ACCEL_ZOUT_H[15:8]	High byte of accelerometer z-axis data.

**Register Name:** ACCEL\_ZOUT\_L  
**Register Type:** READ only  
**Register Address:** 64 (Decimal); 40 (Hex)

BIT	NAME	FUNCTION
[7:0]	ACCEL_ZOUT_L[7:0]	Low byte of accelerometer z-axis data.

**11.23 REGISTERS 65 AND 66 – TEMPERATURE MEASUREMENT**

**Register Name: TEMP\_OUT\_H**

**Register Type: READ only**

**Register Address: 65 (Decimal); 41 (Hex)**

BIT	NAME	FUNCTION
[7:0]	TEMP_OUT[15:8]	High byte of the temperature sensor output

**Register Name: TEMP\_OUT\_L**

**Register Type: READ only**

**Register Address: 66 (Decimal); 42 (Hex)**

BIT	NAME	FUNCTION
[7:0]	TEMP_OUT[7:0]	Low byte of the temperature sensor output $\text{TEMP\_degC} = ((\text{TEMP\_OUT} - \text{RoomTemp\_Offset}) / \text{Temp\_Sensitivity}) + 25\text{degC}$

**11.24 REGISTERS 67 TO 72 – GYROSCOPE MEASUREMENTS**

**Register Name:** GYRO\_XOUT\_H  
**Register Type:** READ only  
**Register Address:** 67 (Decimal); 43 (Hex)

BIT	NAME	FUNCTION
[7:0]	GYRO_XOUT[15:8]	High byte of the X-Axis gyroscope output

**Register Name:** GYRO\_XOUT\_L  
**Register Type:** READ only  
**Register Address:** 68 (Decimal); 44 (Hex)

BIT	NAME	FUNCTION
[7:0]	GYRO_XOUT[7:0]	Low byte of the X-Axis gyroscope output <b>GYRO_XOUT</b> = Gyro_Sensitivity * X_angular_rate Nominal FS_SEL = 0 Conditions Gyro_Sensitivity = 131 LSB/(°/s)

**Register Name:** GYRO\_YOUT\_H  
**Register Type:** READ only  
**Register Address:** 69 (Decimal); 45 (Hex)

BIT	NAME	FUNCTION
[7:0]	GYRO_YOUT[15:8]	High byte of the Y-Axis gyroscope output

**Register Name:** GYRO\_YOUT\_L  
**Register Type:** READ only  
**Register Address:** 70 (Decimal); 46 (Hex)

BIT	NAME	FUNCTION
[7:0]	GYRO_YOUT[7:0]	Low byte of the Y-Axis gyroscope output <b>GYRO_YOUT</b> = Gyro_Sensitivity * Y_angular_rate Nominal FS_SEL = 0 Conditions Gyro_Sensitivity = 131 LSB/(°/s)

**Register Name:** GYRO\_ZOUT\_H  
**Register Type:** READ only  
**Register Address:** 71 (Decimal); 47 (Hex)

BIT	NAME	FUNCTION
[7:0]	GYRO_ZOUT[15:8]	High byte of the Z-Axis gyroscope output

**Register Name:** GYRO\_ZOUT\_L  
**Register Type:** READ only  
**Register Address:** 72 (Decimal); 48 (Hex)

BIT	NAME	FUNCTION
[7:0]	GYRO_ZOUT[7:0]	Low byte of the Z-Axis gyroscope output <b>GYRO_ZOUT</b> = Gyro_Sensitivity * Z_angular_rate Nominal FS_SEL = 0 Conditions Gyro_Sensitivity = 131 LSB/(°/s)

### 11.25 REGISTER 104 – SIGNAL PATH RESET

**Register Name:** SIGNAL\_PATH\_RESET  
**Register Type:** READ/WRITE  
**Register Address:** 104 (Decimal); 68 (Hex)

BIT	NAME	FUNCTION
[7:2]	-	Reserved
[1]	ACCEL_RST	Reset accel digital signal path. Note: Sensor registers are not cleared. Use SIG_COND_RST to clear sensor registers.
[0]	TEMP_RST	Reset temp digital signal path. Note: Sensor registers are not cleared. Use SIG_COND_RST to clear sensor registers.

### 11.26 REGISTER 105 – ACCELEROMETER INTELLIGENCE CONTROL

**Register Name:** ACCEL\_INTEL\_CTRL  
**Register Type:** READ/WRITE  
**Register Address:** 105 (Decimal); 69 (Hex)

BIT	NAME	FUNCTION
[7]	ACCEL_INTEL_EN	This bit enables the Wake-on-Motion detection logic
[6]	ACCEL_INTEL_MODE	0 – Do not use 1 – Compare the current sample with the previous sample
[5:0]	-	Reserved

### 11.27 REGISTER 106 – USER CONTROL

**Register Name:** USER\_CTRL  
**Register Type:** READ/WRITE  
**Register Address:** 106 (Decimal); 6A (Hex)

BIT	NAME	FUNCTION
[7]	DMP_EN	Enable DMP.
[6]	FIFO_EN	1 – Enable FIFO operation mode. 0 – Disable FIFO access from serial interface. To disable FIFO writes by DMA, use FIFO_EN register. To disable possible FIFO writes from DMP, disable the DMP.
[5]	-	Reserved
[4]	I2C_IF_DIS	1 – Disable I2C Slave module and put the serial interface in SPI mode only.
[3]	DMP_RST	Reset DMP.
[2]	FIFO_RST	1 – Reset FIFO module. Reset is asynchronous. This bit auto clears after one clock cycle of the internal 20MHz clock.
[1]	-	Reserved
[0]	SIG_COND_RST	1 – Reset all gyro digital signal path, accel digital signal path, and temp digital signal path. This bit also clears all the sensor registers.

**11.28 REGISTER 107 – POWER MANAGEMENT 1**

**Register Name:** PWR\_MGMT\_1  
**Register Type:** READ/WRITE  
**Register Address:** 107 (Decimal); 6B (Hex)

BIT	NAME	FUNCTION																		
[7]	DEVICE_RESET	1 – Reset the internal registers and restores the default settings. The bit automatically clears to 0 once the reset is done.																		
[6]	SLEEP	1 – The chip is set to sleep mode. Note: The default value is 1; the chip comes up in Sleep mode																		
[5]	ACCEL_CYCLE	When set to 1, and SLEEP and STANDBY are not set to 1, the chip will cycle between sleep and taking a single accelerometer sample at a rate determined by SMPLRT_DIV NOTE: When all accelerometer axes are disabled via PWR_MGMT_2 register bits and cycle is enabled, the chip will wake up at the rate determined by the respective registers above, but will not take any samples.																		
[4]	GYRO_STANDBY	When set, the gyro drive and pll circuitry are enabled, but the sense paths are disabled. This is a low power mode that allows quick enabling of the gyros.																		
[3]	TEMP_DIS	When set to 1, this bit disables the temperature sensor.																		
[2:0]	CLKSEL[2:0]	<table border="0"> <tr> <td><b>Code</b></td> <td><b>Clock Source</b></td> </tr> <tr> <td>0</td> <td>Internal 20 MHz oscillator</td> </tr> <tr> <td>1</td> <td>Auto selects the best available clock source – PLL if ready, else use the Internal oscillator</td> </tr> <tr> <td>2</td> <td>Auto selects the best available clock source – PLL if ready, else use the Internal oscillator</td> </tr> <tr> <td>3</td> <td>Auto selects the best available clock source – PLL if ready, else use the Internal oscillator</td> </tr> <tr> <td>4</td> <td>Auto selects the best available clock source – PLL if ready, else use the Internal oscillator</td> </tr> <tr> <td>5</td> <td>Auto selects the best available clock source – PLL if ready, else use the Internal oscillator</td> </tr> <tr> <td>6</td> <td>Internal 20 MHz oscillator</td> </tr> <tr> <td>7</td> <td>Stops the clock and keeps timing generator in reset</td> </tr> </table>	<b>Code</b>	<b>Clock Source</b>	0	Internal 20 MHz oscillator	1	Auto selects the best available clock source – PLL if ready, else use the Internal oscillator	2	Auto selects the best available clock source – PLL if ready, else use the Internal oscillator	3	Auto selects the best available clock source – PLL if ready, else use the Internal oscillator	4	Auto selects the best available clock source – PLL if ready, else use the Internal oscillator	5	Auto selects the best available clock source – PLL if ready, else use the Internal oscillator	6	Internal 20 MHz oscillator	7	Stops the clock and keeps timing generator in reset
<b>Code</b>	<b>Clock Source</b>																			
0	Internal 20 MHz oscillator																			
1	Auto selects the best available clock source – PLL if ready, else use the Internal oscillator																			
2	Auto selects the best available clock source – PLL if ready, else use the Internal oscillator																			
3	Auto selects the best available clock source – PLL if ready, else use the Internal oscillator																			
4	Auto selects the best available clock source – PLL if ready, else use the Internal oscillator																			
5	Auto selects the best available clock source – PLL if ready, else use the Internal oscillator																			
6	Internal 20 MHz oscillator																			
7	Stops the clock and keeps timing generator in reset																			

Note: The default value of CLKSEL[2:0] is 000. It is required that CLKSEL[2:0] be set to 001 to achieve full gyroscope performance.

**11.29 REGISTER 108 – POWER MANAGEMENT 2**

**Register Name:** PWR\_MGMT\_2  
**Register Type:** READ/WRITE  
**Register Address:** 108 (Decimal); 6C (Hex)

BIT	NAME	FUNCTION
[7]	FIFO_LP_EN	1 – Enable FIFO in low-power accelerometer mode. Default setting is 0.
[6]	DMP_LP_DIS	1 - Disable DMP execution in low-power accelerometer mode. Default setting is 0.
[5]	STBY_XA	1 – X accelerometer is disabled 0 – X accelerometer is on
[4]	STBY_YA	1 – Y accelerometer is disabled 0 – Y accelerometer is on
[3]	STBY_ZA	1 – Z accelerometer is disabled 0 – Z accelerometer is on
[2]	STBY_XG	1 – X gyro is disabled 0 – X gyro is on
[1]	STBY_YG	1 – Y gyro is disabled 0 – Y gyro is on
[0]	STBY_ZG	1 – Z gyro is disabled 0 – Z gyro is on

### 11.30 REGISTER 114 AND 115 – FIFO COUNT REGISTERS

**Register Name:** FIFO\_COUNTH  
**Register Type:** READ Only  
**Register Address:** 114 (Decimal); 72 (Hex)

BIT	NAME	FUNCTION
[7:5]	-	Reserved
[4:0]	FIFO_COUNT[12:8]	High Bits, count indicates the number of written bytes in the FIFO. Reading this byte latches the data for both FIFO_COUNTH, and FIFO_COUNTL.

**Register Name:** FIFO\_COUNTL  
**Register Type:** READ Only  
**Register Address:** 115 (Decimal); 73 (Hex)

BIT	NAME	FUNCTION
[7:0]	FIFO_COUNT[7:0]	Low Bits, count indicates the number of written bytes in the FIFO. NOTE: Must read FIFO_COUNTH to latch new data for both FIFO_COUNTH and FIFO_COUNTL.

### 11.31 REGISTER 116 – FIFO READ WRITE

**Register Name:** FIFO\_R\_W  
**Register Type:** READ/WRITE  
**Register Address:** 116 (Decimal); 74 (Hex)

BIT	NAME	FUNCTION
[7:0]	FIFO_DATA[7:0]	Read/Write command provides Read or Write operation for the FIFO.

**Description:**

This register is used to read and write data from the FIFO buffer.

Data is written to the FIFO in order of register number (from lowest to highest). If all the FIFO enable flags (see below) are enabled, the contents of registers 59 through 72 will be written in order at the Sample Rate.

The contents of the sensor data registers (Registers 59 to 72) are written into the FIFO buffer when their corresponding FIFO enable flags are set to 1 in FIFO\_EN (Register 35).

If the FIFO buffer has overflowed, the status bit *FIFO\_OVERFLOW\_INT* is automatically set to 1. This bit is located in INT\_STATUS (Register 58). When the FIFO buffer has overflowed, the oldest data will be lost and new data will be written to the FIFO unless register 26 CONFIG, bit[6] FIFO\_MODE = 1.

If the FIFO buffer is empty, reading register FIFO\_DATA will return a unique value of 0xFF until new data is available.

Normal data is precluded from ever indicating 0xFF, so 0xFF gives a trustworthy indication of FIFO empty.

### 11.32 REGISTER 117 – WHO AM I

**Register Name:** WHO\_AM\_I  
**Register Type:** READ only  
**Register Address:** 117 (Decimal); 75 (Hex)

BIT	NAME	FUNCTION
[7:0]	WHOAMI	Register to indicate to user which device is being accessed.

This register is used to verify the identity of the device. The contents of *WHOAMI* is an 8-bit device ID. The default value of the register is 0x98. This is different from the I2C address of the device as seen on the slave I2C controller by the applications processor. The I2C address of the ICM-20689 is 0x68 or 0x69 depending upon the value driven on AD0 pin.

### 11.33 REGISTERS 119, 120, 122, 123, 125, 126 ACCELEROMETER OFFSET REGISTERS

**Register Name:** XA\_OFFSET\_H  
**Register Type:** READ/WRITE  
**Register Address:** 119 (Decimal); 77 (Hex)

BIT	NAME	FUNCTION
[7:0]	XA_OFFS[14:7]	Upper bits of the X accelerometer offset cancellation. +/- 16g Offset cancellation in all Full Scale modes, 15 bit 0.98-mg steps

**Register Name:** XA\_OFFSET\_L  
**Register Type:** READ/WRITE  
**Register Address:** 120 (Decimal); 78 (Hex)

BIT	NAME	FUNCTION
[7:1]	XA_OFFS[6:0]	Lower bits of the X accelerometer offset cancellation. +/- 16g Offset cancellation in all Full Scale modes, 15 bit 0.98-mg steps
[0]	-	Reserved

**Register Name:** YA\_OFFSET\_H  
**Register Type:** READ/WRITE  
**Register Address:** 122 (Decimal); 7A (Hex)

BIT	NAME	FUNCTION
[7:0]	YA_OFFS[14:7]	Upper bits of the Y accelerometer offset cancellation. +/- 16g Offset cancellation in all Full Scale modes, 15 bit 0.98-mg steps

**Register Name:** YA\_OFFSET\_L  
**Register Type:** READ/WRITE  
**Register Address:** 123 (Decimal); 7B (Hex)

BIT	NAME	FUNCTION
[7:1]	YA_OFFS[6:0]	Lower bits of the Y accelerometer offset cancellation. +/- 16g Offset cancellation in all Full Scale modes, 15 bit 0.98-mg steps
[0]	-	Reserved

**Register Name: ZA\_OFFSET\_H**  
**Register Type: READ/WRITE**  
**Register Address: 125 (Decimal); 7D (Hex)**

BIT	NAME	FUNCTION
[7:0]	ZA_OFFS[14:7]	Upper bits of the Z accelerometer offset cancellation. +/- 16g Offset cancellation in all Full Scale modes, 15 bit 0.98-mg steps

**Register Name: ZA\_OFFSET\_L**  
**Register Type: READ/WRITE**  
**Register Address: 126 (Decimal); 7E (Hex)**

BIT	NAME	FUNCTION
[7:1]	ZA_OFFS[6:0]	Lower bits of the Z accelerometer offset cancellation. +/- 16g Offset cancellation in all Full Scale modes, 15 bit 0.98-mg steps
[0]	-	Reserved

## **12 REFERENCE**

Please refer to “InvenSense MEMS Handling Application Note (AN-IVS-0002A-00)” for the following information:

- Manufacturing Recommendations
  - Assembly Guidelines and Recommendations
  - PCB Design Guidelines and Recommendations
  - MEMS Handling Instructions
  - ESD Considerations
  - Reflow Specification
  - Storage Specifications
  - Package Marking Specification
  - Tape & Reel Specification
  - Reel & Pizza Box Label
  - Packaging
  - Representative Shipping Carton Label
- Compliance
  - Environmental Compliance
  - DRC Compliance
  - Compliance Declaration Disclaimer

### 13 REVISION HISTORY

REVISION DATE	REVISION	DESCRIPTION
06/06/2016	1.0	Initial Release

This information furnished by InvenSense is believed to be accurate and reliable. However, no responsibility is assumed by InvenSense for its use, or for any infringements of patents or other rights of third parties that may result from its use. Specifications are subject to change without notice. InvenSense reserves the right to make changes to this product, including its circuits and software, in order to improve its design and/or performance, without prior notice. InvenSense makes no warranties, neither expressed nor implied, regarding the information and specifications contained in this document. InvenSense assumes no responsibility for any claims or damages arising from information contained in this document, or from the use of products and services detailed therein. This includes, but is not limited to, claims or damages based on the infringement of patents, copyrights, mask work and/or other intellectual property rights.

Certain intellectual property owned by InvenSense and described in this document is patent protected. No license is granted by implication or otherwise under any patent or patent rights of InvenSense. This publication supersedes and replaces all information previously supplied. Trademarks that are registered trademarks are the property of their respective companies. InvenSense sensors should not be used or sold in the development, storage, production or utilization of any conventional or mass-destructive weapons or for any other weapons or life threatening applications, as well as in any other life critical applications such as medical equipment, transportation, aerospace and nuclear instruments, undersea equipment, power plant equipment, disaster prevention and crime prevention equipment.

©2016 InvenSense, Inc. All rights reserved. InvenSense, Sensing Everything, MotionTracking, MotionProcessing, MotionProcessor, MotionFusion, MotionApps, Digital Motion Processor, and the InvenSense logo are trademarks of InvenSense, Inc. Other company and product names may be trademarks of the respective companies with which they are associated.



©2016 InvenSense, Inc. All rights reserved.