

Super Voltage Converter

The ICL7660S Super Voltage Converter is a monolithic CMOS voltage conversion IC that guarantees significant performance advantages over other similar devices. It is a direct replacement for the industry standard ICL7660 offering an **extended** operating supply voltage range up to 12V, with **lower** supply current. **No external diode** is needed for the ICL7660S. In addition, a **Frequency Boost pin** has been incorporated to enable the user to achieve lower output impedance despite using smaller capacitors. All improvements are highlighted in the “Electrical Specifications” section on page 3. **Critical parameters are guaranteed over the entire commercial, industrial and military temperature ranges.**

The ICL7660S performs supply voltage conversion from positive to negative for an input range of 1.5V to 12V, resulting in complementary output voltages of -1.5V to -12V. Only 2 non-critical external capacitors are needed for the charge pump and charge reservoir functions. The ICL7660S can be connected to function as a voltage doubler and will generate up to 22.8V with a 12V input. It can also be used as a voltage multiplier or voltage divider.

The chip contains a series DC power supply regulator, RC oscillator, voltage level translator, and four output power MOS switches. The oscillator, when unloaded, oscillates at a nominal frequency of 10kHz for an input supply voltage of 5.0V. This frequency can be lowered by the addition of an external capacitor to the “OSC” terminal, or the oscillator may be over-driven by an external clock.

The “LV” terminal may be tied to GND to bypass the internal series regulator and improve low voltage (LV) operation. At medium to high voltages (3.5V to 12V), the LV pin is left floating to prevent device latchup.

Pinout

ICL7660S
(8 LD PDIP, SOIC)
TOP VIEW

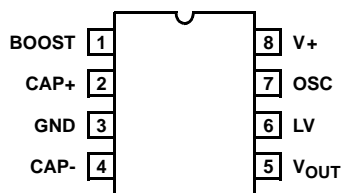

Features

- Guaranteed Lower Max Supply Current for All Temperature Ranges
- Wide Operating Voltage Range 1.5V to 12V
- 100% Tested at 3V
- No External Diode Over Full Temperature and Voltage Range
- Boost Pin (Pin 1) for Higher Switching Frequency
- Guaranteed Minimum Power Efficiency of 96%
- Improved Minimum Open Circuit Voltage Conversion Efficiency of 99%
- Improved SCR Latchup Protection
- Simple Conversion of +5V Logic Supply to ±5V Supplies
- Simple Voltage Multiplication $V_{OUT} = (-)nV_{IN}$
- Easy to Use - Requires Only 2 External Non-Critical Passive Components
- Improved Direct Replacement for Industry Standard ICL7660 and Other Second Source Devices
- Pb-Free Available (RoHS Compliant)

Applications

- Simple Conversion of +5V to ±5V Supplies
- Voltage Multiplication $V_{OUT} = \pm nV_{IN}$
- Negative Supplies for Data Acquisition Systems and Instrumentation
- RS232 Power Supplies
- Supply Splitter, $V_{OUT} = \pm V_S/2$

Ordering Information

PART NUMBER	PART MARKING	TEMP. RANGE (°C)	PACKAGE	PKG. DWG. #
ICL7660SCBA	7660 SCBA	0 to +70	8 Ld SOIC	M8.15
ICL7660SCBA-T (Note 3)	7660 SCBA	0 to +70	8 Ld SOIC Tape and Reel	M8.15
ICL7660SCBAZ (Note 1)	7660 SCBAZ	0 to +70	8 Ld SOIC (Pb-free)	M8.15
ICL7660SCBAZ-T (Notes 1, 3)	7660 SCBAZ	0 to +70	8 Ld SOIC Tape and Reel (Pb-free)	M8.15
ICL7660SCPA	7660S CPA	0 to +70	8 Ld PDIP	E8.3
ICL7660SCPAZ (Note 1)	7660S CPAZ	0 to +70	8 Ld PDIP* (Pb-free)	E8.3
ICL7660SIBA	7660 SIBA	-40 to +85	8 Ld SOIC	M8.15
ICL7660SIBAT (Note 3)	7660 SIBA	-40 to +85	8 Ld SOIC Tape and Reel	M8.15
ICL7660SIBAZ (Note 1)	7660 SIBAZ	-40 to +85	8 Ld SOIC (Pb-free)	M8.15
ICL7660SIBAZT (Notes 1, 3)	7660 SIBAZ	-40 to +85	8 Ld SOIC Tape and Reel (Pb-free)	M8.15
ICL7660SIPA	7660 SIPA	-40 to +85	8 Ld PDIP	E8.3
ICL7660SIPAZ (Note 1)	7660S IPAZ	-40 to +85	8 Ld PDIP* (Pb-free)	E8.3

*Pb-free PDIPs can be used for through hole wave solder processing only. They are not intended for use in Reflow solder processing applications.
NOTES:

1. These Intersil Pb-free plastic packaged products employ special Pb-free material sets; molding compounds/die attach materials and 100% matte tin plate PLUS ANNEAL - e3 termination finish, which is RoHS compliant and compatible with both SnPb and Pb-free soldering operations. Intersil Pb-free products are MSL classified at Pb-free peak reflow temperatures that meet or exceed the Pb-free requirements of IPC/JEDEC J STD-020.
2. Add /883B to part number if 883B processing is required.
3. Please refer to TB347 for details on reel specifications.

Absolute Maximum Ratings

Supply Voltage	+13.0V
LV and OSC Input Voltage (Note 4)	
V+ < 5.5V	-0.3V to V+ + 0.3V
V+ > 5.5V	V+ -5.5V to V+ +0.3V
Current into LV (Note 4)	
V+ > 3.5V	.20μA
Output Short Duration	
V _{SUPPLY} ≤ 5.5V	Continuous
Storage Temperature Range	-65°C to +150°C

Thermal Information

Thermal Resistance (Typical, Note 5)	θ _{JA} (°C/W)
8 Ld PDIP*	110
8 Ld Plastic SOIC	160
Pb-free reflow profile	see link below
	http://www.intersil.com/pbfree/Pb-FreeReflow.asp

*Pb-free PDIPs can be used for through hole wave solder processing only. They are not intended for use in Reflow solder processing applications.

Operating Conditions

Temperature Range	
ICL7660SI	-40°C to +85°C
ICL7660SC	0°C to +70°C

CAUTION: Do not operate at or near the maximum ratings listed for extended periods of time. Exposure to such conditions may adversely impact product reliability and result in failures not covered by warranty.

NOTES:

- Connecting any terminal to voltages greater than V+ or less than GND may cause destructive latchup. It is recommended that no inputs from sources operating from external supplies be applied prior to "power up" of ICL7660S.
- θ_{JA} is measured with the component mounted on an evaluation PC board in free air.

Electrical Specifications V+ = 5V, T_A = +25°C, OSC = Free running, Test Circuit Figure 12, Unless Otherwise Specified.

PARAMETER	SYMBOL	TEST CONDITIONS	MIN	TYP	MAX	UNITS
Supply Current (Note 8)	I+	R _L = ∞, +25°C	-	80	160	μA
		0°C < T _A < +70°C	-	-	180	μA
		-40°C < T _A < +85°C	-	-	180	μA
		-55°C < T _A < +125°C	-	-	200	μA
Supply Voltage Range - High (Note 9)	V _{+H}	R _L = 10k, LV Open, T _{MIN} < T _A < T _{MAX}	3.0	-	12	V
Supply Voltage Range - Low	V _{+L}	R _L = 10k, LV to GND, T _{MIN} < T _A < T _{MAX}	1.5	-	3.5	V
Output Source Resistance	R _{OUT}	I _{OUT} = 20mA	-	60	100	Ω
		I _{OUT} = 20mA, 0°C < T _A < +70°C	-	-	120	Ω
		I _{OUT} = 20mA, -25°C < T _A < +85°C	-	-	120	Ω
		I _{OUT} = 20mA, -55°C < T _A < +125°C	-	-	150	Ω
		I _{OUT} = 3mA, V+ = 2V, LV = GND, 0°C < T _A < +70°C	-	-	250	Ω
		I _{OUT} = 3mA, V+ = 2V, LV = GND, -40°C < T _A < +85°C	-	-	300	Ω
		I _{OUT} = 3mA, V+ = 2V, LV = GND, -55°C < T _A < +125°C	-	-	400	Ω
Oscillator Frequency (Note 7)	f _{OSC}	C _{OSC} = 0, Pin 1 Open or GND	5	10	-	kHz
		C _{OSC} = 0, Pin 1 = V+	-	35	-	kHz
Power Efficiency	P _{EFF}	R _L = 5kΩ	96	98	-	%
		T _{MIN} < T _A < T _{MAX} R _L = 5kΩ	95	97	-	-
Voltage Conversion Efficiency	V _{OUTEFF}	R _L = ∞	99	99.9	-	%

Electrical Specifications $V_+ = 5V$, $T_A = +25^\circ C$, OSC = Free running, Test Circuit Figure 12, Unless Otherwise Specified. (Continued)

PARAMETER	SYMBOL	TEST CONDITIONS	MIN	TYP	MAX	UNITS
Oscillator Impedance	Z_{OSC}	$V_+ = 2V$	-	1	-	$M\Omega$
		$V_+ = 5V$	-	100	-	$k\Omega$

NOTES:

- Derate linearly above $+50^\circ C$ by $5.5mW/^\circ C$
- In the test circuit, there is no external capacitor applied to pin 7. However, when the device is plugged into a test socket, there is usually a very small but finite stray capacitance present, of the order of $5pF$.
- The Intersil ICL7660S can operate without an external diode over the full temperature and voltage range. This device will function in existing designs which incorporate an external diode with no degradation in overall circuit performance.
- All significant improvements over the industry standard ICL7660 are highlighted.

Typical Performance Curves (Test Circuit Figure 12)

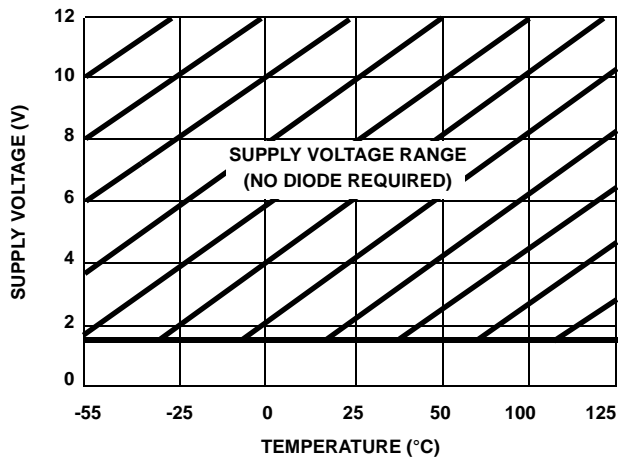

FIGURE 1. OPERATING VOLTAGE AS A FUNCTION OF TEMPERATURE

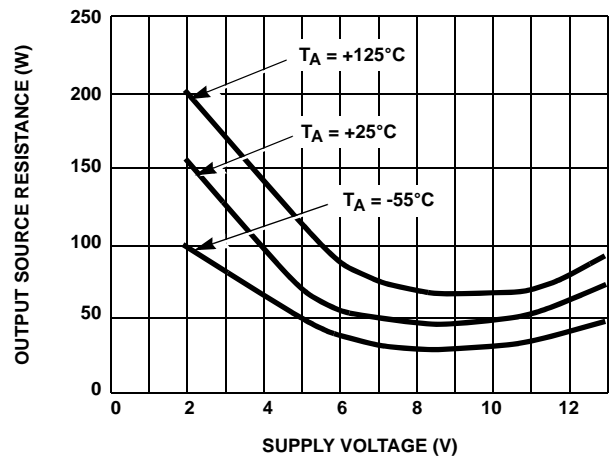

FIGURE 2. OUTPUT SOURCE RESISTANCE AS A FUNCTION OF SUPPLY VOLTAGE

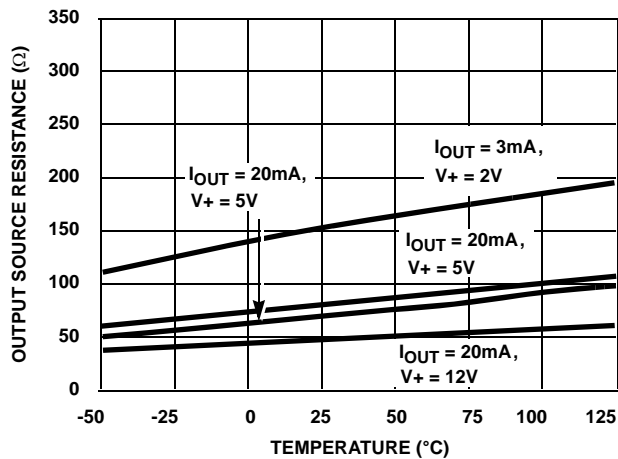

FIGURE 3. OUTPUT SOURCE RESISTANCE AS A FUNCTION OF TEMPERATURE

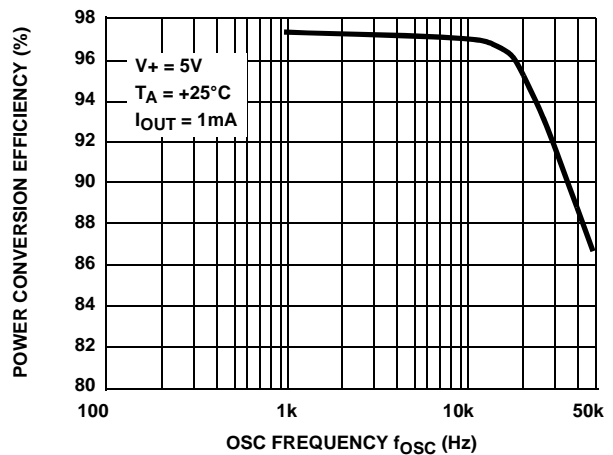

FIGURE 4. POWER CONVERSION EFFICIENCY AS A FUNCTION OF OSCILLATOR FREQUENCY

Typical Performance Curves (Test Circuit Figure 12) (Continued)

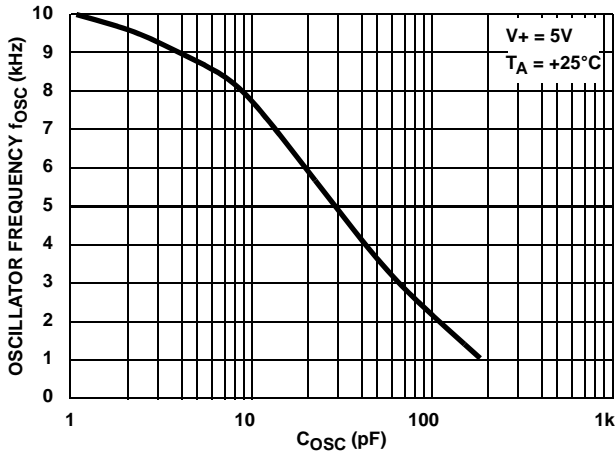

FIGURE 5. FREQUENCY OF OSCILLATION AS A FUNCTION OF EXTERNAL OSCILLATOR CAPACITANCE

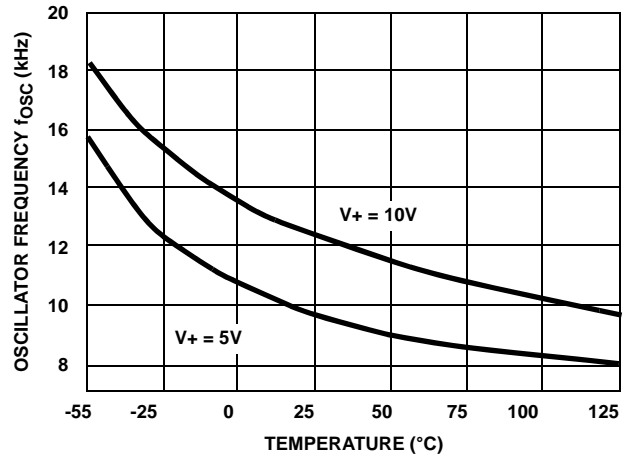

FIGURE 6. UNLOADED OSCILLATOR FREQUENCY AS A FUNCTION OF TEMPERATURE

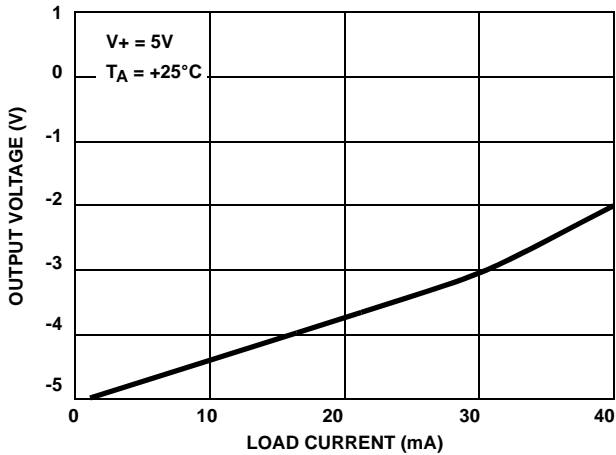

FIGURE 7. OUTPUT VOLTAGE AS A FUNCTION OF OUTPUT CURRENT

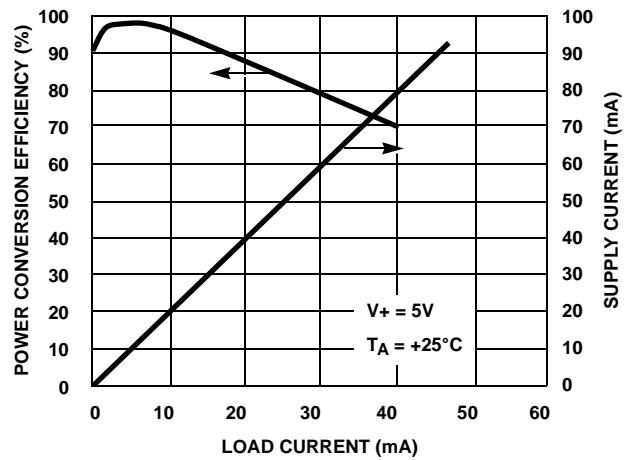

FIGURE 8. SUPPLY CURRENT AND POWER CONVERSION EFFICIENCY AS A FUNCTION OF LOAD CURRENT

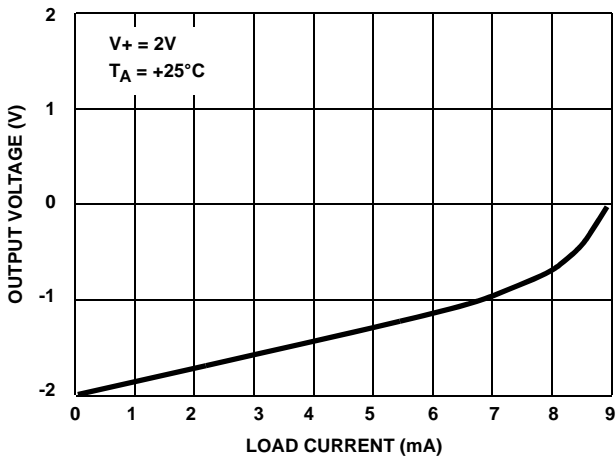

FIGURE 9. OUTPUT VOLTAGE AS A FUNCTION OF OUTPUT CURRENT

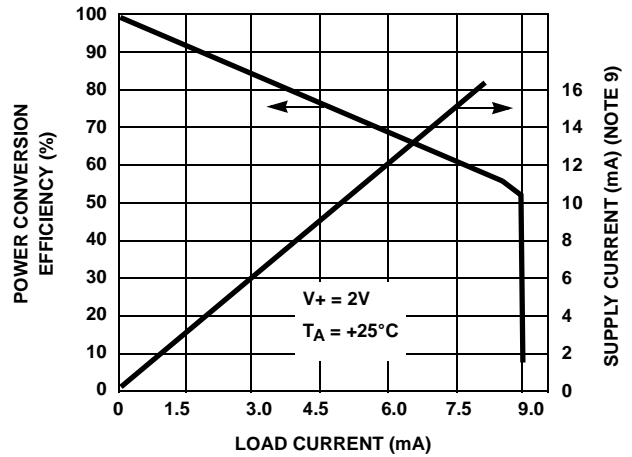

FIGURE 10. SUPPLY CURRENT AND POWER CONVERSION EFFICIENCY AS A FUNCTION OF LOAD CURRENT

Typical Performance Curves (Test Circuit Figure 12) (Continued)

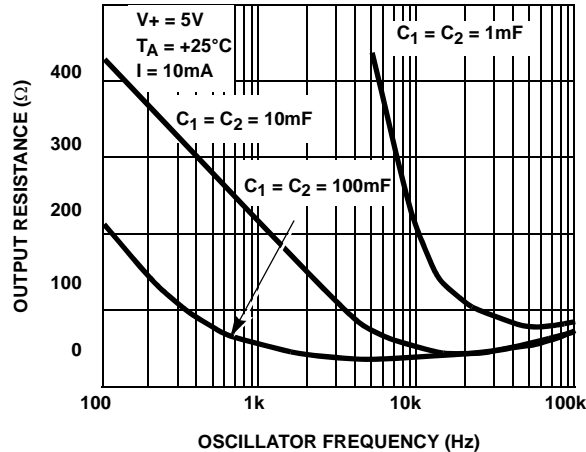

FIGURE 11. OUTPUT SOURCE RESISTANCE AS A FUNCTION OF OSCILLATOR FREQUENCY

NOTE:

- These curves include in the supply current that current fed directly into the load R_L from the V_+ (See Figure 12). Thus, approximately half the supply current goes directly to the positive side of the load, and the other half, through the ICL7660S, to the negative side of the load. Ideally, $V_{OUT} \approx 2V_{IN}$, $I_S \approx 2I_L$, so $V_{IN} \times I_S \approx V_{OUT} \times I_L$.

Detailed Description

The ICL7660S contains all the necessary circuitry to complete a negative voltage converter, with the exception of 2 external capacitors which may be inexpensive 10 μ F polarized electrolytic types. The mode of operation of the device may be best understood by considering Figure 12, which shows an idealized negative voltage converter. Capacitor C_1 is charged to a voltage, V_+ , for the half cycle when switches S_1 and S_3 are closed. (Note: Switches S_2 and S_4 are open during this half cycle). During the second half cycle of operation, switches S_2 and S_4 are closed, with S_1 and S_3 open, thereby shifting capacitor C_1 to C_2 such that the voltage on C_2 is exactly V_+ , assuming ideal switches and no load on C_2 . The ICL7660S approaches this ideal situation more closely than existing non-mechanical circuits.

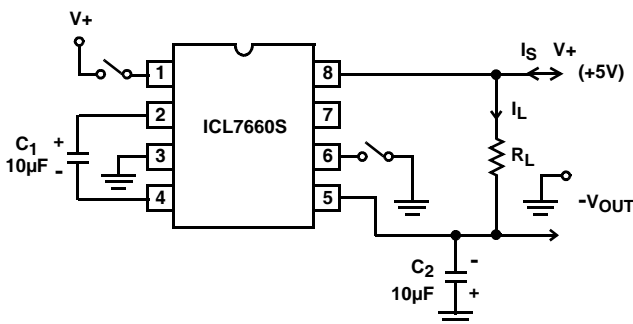

NOTE: For large values of C_{OSC} (>1000pF) the values of C_1 and C_2 should be increased to 100 μ F.

FIGURE 12. ICL7660S TEST CIRCUIT

In the ICL7660S, the 4 switches of Figure 13 are MOS power switches; S_1 is a P-Channel devices and S_2 , S_3 and S_4 are N-Channel devices. The main difficulty with this

approach is that in integrating the switches, the substrates of S_3 and S_4 must always remain reverse biased with respect to their sources, but not so much as to degrade their "ON" resistances. In addition, at circuit start-up, and under output short circuit conditions ($V_{OUT} = V_+$), the output voltage must be sensed and the substrate bias adjusted accordingly. Failure to accomplish this would result in high power losses and probable device latch-up.

This problem is eliminated in the ICL7660S by a logic network which senses the output voltage (V_{OUT}) together with the level translators, and switches the substrates of S_3 and S_4 to the correct level to maintain necessary reverse bias.

The voltage regulator portion of the ICL7660S is an integral part of the anti-latchup circuitry, however its inherent voltage drop can degrade operation at low voltages. Therefore, to improve low voltage operation "LV" pin should be connected to GND, disabling the regulator. For supply voltages greater than 3.5V the LV terminal must be left open to insure latchup proof operation, and prevent device damage.

Theoretical Power Efficiency Considerations

In theory, a voltage converter can approach 100% efficiency if certain conditions are met:

- The drive circuitry consumes minimal power.
- The output switches have extremely low ON resistance and virtually no offset.
- The impedance of the pump and reservoir capacitors are negligible at the pump frequency.

The ICL7660S approaches these conditions for negative voltage conversion if large values of C_1 and C_2 are used. **ENERGY IS LOST ONLY IN THE TRANSFER OF CHARGE BETWEEN CAPACITORS IF A CHANGE IN VOLTAGE OCCURS.** The energy lost is defined by:

$$E = \frac{1}{2}C_1(V_1^2 - V_2^2) \quad (\text{EQ. 1})$$

where V_1 and V_2 are the voltages on C_1 during the pump and transfer cycles. If the impedances of C_1 and C_2 are relatively high at the pump frequency (refer to Figure 13) compared to the value of R_L , there will be substantial difference in the voltages V_1 and V_2 . Therefore it is not only desirable to make C_2 as large as possible to eliminate output voltage ripple, but also to employ a correspondingly large value for C_1 in order to achieve maximum efficiency of operation.

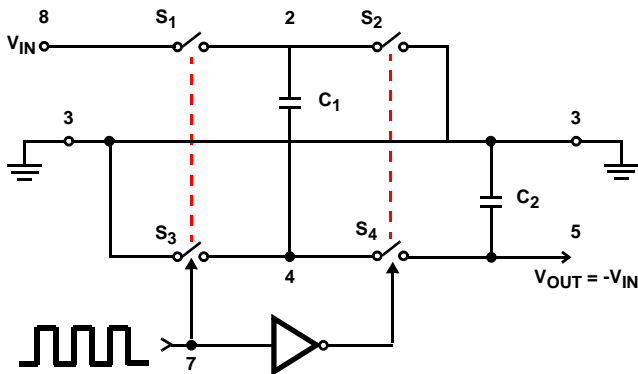

FIGURE 13. IDEALIZED NEGATIVE VOLTAGE CONVERTER

Do's and Don'ts

1. Do not exceed maximum supply voltages.
2. Do not connect LV terminal to GND for supply voltage greater than 3.5V.
3. Do not short circuit the output to V^+ supply for supply voltages above 5.5V for extended periods, however, transient conditions including start-up are okay.
4. When using polarized capacitors, the + terminal of C_1 must be connected to pin 2 of the ICL7660S and the + terminal of C_2 must be connected to GND.
5. If the voltage supply driving the ICL7660S has a large source impedance (25Ω to 30Ω), then a $2.2\mu\text{F}$ capacitor from pin 8 to ground may be required to limit rate of rise of input voltage to less than $2\text{V}/\mu\text{s}$.
6. User should insure that the output (pin 5) does not go more positive than GND (pin 3). Device latch up will occur under these conditions. A 1N914 or similar diode placed in parallel with C_2 will prevent the device from latching up under these conditions. (Anode pin 5, Cathode pin 3).

Typical Applications

Simple Negative Voltage Converter

The majority of applications will undoubtedly utilize the ICL7660S for generation of negative supply voltages. Figure 14 shows typical connections to provide a negative supply where a positive supply of +1.5V to +12V is available. Keep in mind that pin 6 (LV) is tied to the supply negative (GND) for supply voltage below 3.5V.

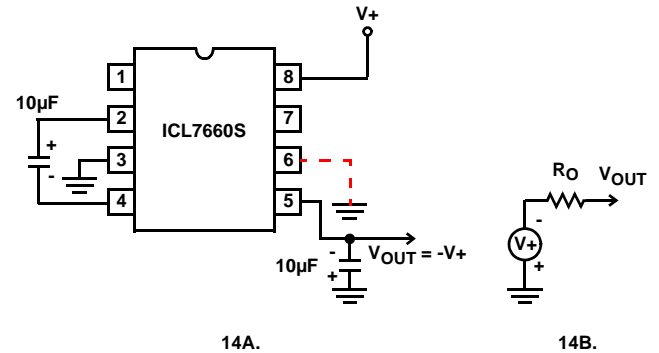

FIGURE 14. SIMPLE NEGATIVE CONVERTER AND ITS OUTPUT EQUIVALENT

The output characteristics of the circuit in Figure 14 can be approximated by an ideal voltage source in series with a resistance as shown in Figure 14B. The voltage source has a value of $-(V^+)$. The output impedance (R_0) is a function of the ON resistance of the internal MOS switches (shown in Figure 13), the switching frequency, the value of C_1 and C_2 , and the ESR (equivalent series resistance) of C_1 and C_2 . A good first order approximation for R_0 is:

$$R_0 \cong 2((R_{SW1} + R_{SW3} + ESR_{C1}) + 2(R_{SW2} + R_{SW4} + ESR_{C1}) + \frac{1}{f_{PUMP} \times C_1} + ESR_{C2})$$

$$f_{PUMP} = \frac{f_{OSC}}{2} \quad (R_{SWX} = \text{MOSFET Switch Resistance}) \quad (\text{EQ. 2})$$

Combining the four R_{SWX} terms as R_{SW} , we see that:

$$R_0 \cong 2 \times R_{SW} + \frac{1}{f_{PUMP} \times C_1} + 4 \times ESR_{C1} + ESR_{C2} \quad (\text{EQ. 3})$$

R_{SW} , the total switch resistance, is a function of supply voltage and temperature (See the Output Source Resistance graphs), typically 23Ω at $+25^\circ\text{C}$ and 5V. Careful selection of C_1 and C_2 will reduce the remaining terms, minimizing the output impedance. High value capacitors will reduce the $1/(f_{PUMP} \times C_1)$ component, and low ESR capacitors will lower the ESR term. Increasing the oscillator frequency will reduce the $1/(f_{PUMP} \times C_1)$ term, but may have the side effect of a net increase in output impedance when $C_1 > 10\mu\text{F}$ and is not long enough to fully charge the capacitors every cycle. In a typical application where $f_{OSC} = 10\text{kHz}$ and $C = C_1 = C_2 = 10\mu\text{F}$:

$$R_0 \cong 2 \times 23 + \frac{1}{5 \times 10^3 \times 10 \times 10^{-6}} + 4 \times \text{ESR}_{C_1} + \text{ESR}_{C_2} \quad (\text{EQ. 4})$$

$$R_0 \cong 46 + 20 + 5 \times \text{ESR}_C$$

Since the ESRs of the capacitors are reflected in the output impedance multiplied by a factor of 5, a high value could potentially swamp out a low $1/f_{\text{PUMP}} \times C_1$ term, rendering an increase in switching frequency or filter capacitance ineffective. Typical electrolytic capacitors may have ESRs as high as 10Ω .

Output Ripple

ESR also affects the ripple voltage seen at the output. The total ripple is determined by 2 voltages, A and B, as shown in Figure 15. Segment A is the voltage drop across the ESR of C_2 at the instant it goes from being charged by C_1 (current flowing into C_2) to being discharged through the load (current flowing out of C_2). The magnitude of this current change is $2 \times I_{\text{OUT}}$, hence the total drop is $2 \times I_{\text{OUT}} \times \text{ESR}_{C_2}V$. Segment B is the voltage change across C_2 during time t_2 , the half of the cycle when C_2 supplies current the load. The drop at B is $I_{\text{OUT}} \times t_2/C_2V$. The peak-to-peak ripple voltage is the sum of these voltage drops:

$$V_{\text{RIPPLE}} \cong \left(\frac{1}{2 \times f_{\text{PUMP}} \times C_2} + 2 \text{ESR}_{C_2} \times I_{\text{OUT}} \right) \quad (\text{EQ. 5})$$

Again, a low ESR capacitor will result in a higher performance output.

Paralleling Devices

Any number of ICL7660S voltage converters may be paralleled to reduce output resistance. The reservoir capacitor, C_2 , serves all devices while each device requires its own pump capacitor, C_1 . The resultant output resistance would be approximately:

$$R_{\text{OUT}} = \frac{R_{\text{OUT}}(\text{of ICL7660S})}{n(\text{number of devices})} \quad (\text{EQ. 6})$$

Cascading Devices

The ICL7660S may be cascaded as shown to produce larger negative multiplication of the initial supply voltage. However, due to the finite efficiency of each device, the practical limit is 10 devices for light loads. The output voltage is defined by:

$$V_{\text{OUT}} = -n(V_{\text{IN}}) \quad (\text{EQ. 7})$$

where n is an integer representing the number of devices cascaded. The resulting output resistance would be approximately the weighted sum of the individual ICL7660S R_{OUT} values.

Changing the ICL7660S Oscillator Frequency

It may be desirable in some applications, due to noise or other considerations, to alter the oscillator frequency. This can be achieved simply by one of several methods described in the following.

By connecting the Boost Pin (Pin 1) to V_+ , the oscillator charge and discharge current is increased and, hence, the oscillator frequency is increased by approximately $3^{1/2}$ times. The result is a decrease in the output impedance and ripple. This is of major importance for surface mount applications where capacitor size and cost are critical. Smaller capacitors, e.g. $0.1\mu\text{F}$, can be used in conjunction with the Boost Pin in order to achieve similar output currents compared to the device free running with $C_1 = C_2 = 10\mu\text{F}$ or $100\mu\text{F}$. (Refer to graph of Output Source Resistance as a Function of Oscillator Frequency).

Increasing the oscillator frequency can also be achieved by overdriving the oscillator from an external clock, as shown in Figure 18. In order to prevent device latchup, a $1\text{k}\Omega$ resistor must be used in series with the clock output. In a situation where the designer has generated the external clock frequency using TTL logic, the addition of a $10\text{k}\Omega$ pull-up resistor to V_+ supply is required. Note that the pump frequency with external clocking, as with internal clocking, will be $1/2$ of the clock frequency. Output transitions occur on the positive going edge of the clock.

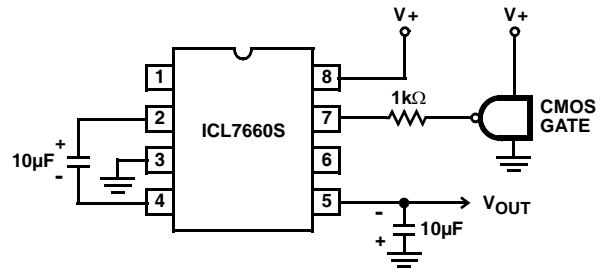

FIGURE 15. EXTERNAL CLOCKING

It is also possible to increase the conversion efficiency of the ICL7660S at low load levels by lowering the oscillator frequency. This reduces the switching losses, and is shown in Figure 19. However, lowering the oscillator frequency will cause an undesirable increase in the impedance of the pump (C_1) and reservoir (C_2) capacitors; this is overcome by increasing the values of C_1 and C_2 by the same factor that the frequency has been reduced. For example, the addition of a 100pF capacitor between pin 7 (OSC and V_+) will lower the oscillator frequency to 1kHz from its nominal frequency of 10kHz (a multiple of 10), and thereby necessitate corresponding increase in the value of C_1 and C_2 (from $10\mu\text{F}$ to $100\mu\text{F}$).

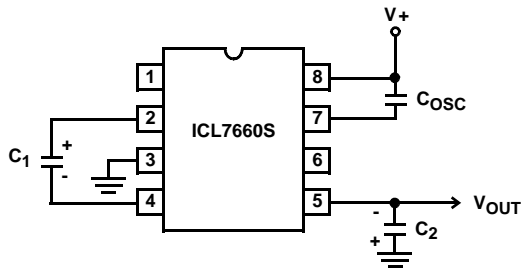
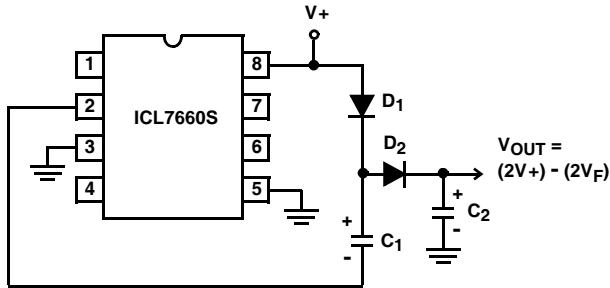

FIGURE 16. LOWERING OSCILLATOR FREQUENCY

Positive Voltage Doubling

The ICL7660S may be employed to achieve positive voltage doubling using the circuit shown in Figure 20. In this application, the pump inverter switches of the ICL7660S are used to charge C_1 to a voltage level of $V_+ - V_F$ (where V_+ is the supply voltage and V_F is the forward voltage on C_1 plus the supply voltage (V_+) is applied through diode D_2 to capacitor C_2 . The voltage thus created on C_2 becomes $(2V_+) - (2V_F)$ or twice the supply voltage minus the combined forward voltage drops of diodes D_1 and D_2 .

The source impedance of the output (V_{OUT}) will depend on the output current, but for $V_+ = 5V$ and an output current of 10mA it will be approximately 60Ω.



NOTE: D_1 and D_2 can be any suitable diode.

FIGURE 17. POSITIVE VOLTAGE DOUBLER

Combined Negative Voltage Conversion and Positive Supply Doubling

Figure 21 combines the functions shown in Figure 14 and Figure 20 to provide negative voltage conversion and positive voltage doubling simultaneously. This approach would be, for example, suitable for generating +9V and -5V from an existing +5V supply. In this instance capacitors C_1 and C_3 perform the pump and reservoir functions respectively for the generation of the negative voltage, while capacitors C_2 and C_4 are pump and reservoir respectively for the doubled positive voltage. There is a penalty in this configuration which combines both functions, however, in that the source impedances of the generated supplies will be somewhat higher due to the finite impedance of the common charge pump driver at pin 2 of the device.

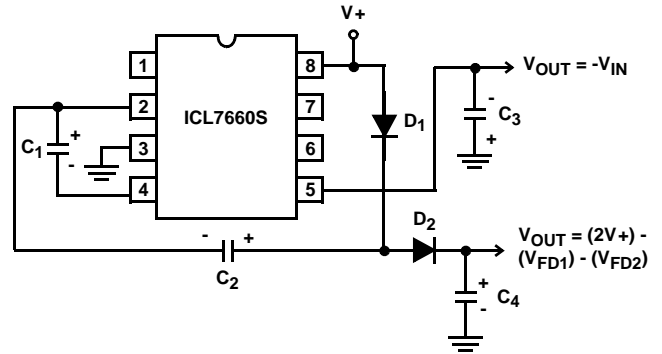

FIGURE 18. COMBINED NEGATIVE VOLTAGE CONVERTER AND POSITIVE DOUBLER

Voltage Splitting

The bidirectional characteristics can also be used to split a high supply in half, as shown in Figure 22. The combined load will be evenly shared between the two sides, and a high value resistor to the LV pin ensures start-up. Because the switches share the load in parallel, the output impedance is much lower than in the standard circuits, and higher currents can be drawn from the device. By using this circuit, and then the circuit of Figure 17, +15V can be converted (via +7.5, and -7.5 to a nominal -15V, although with rather high series output resistance (~250Ω).

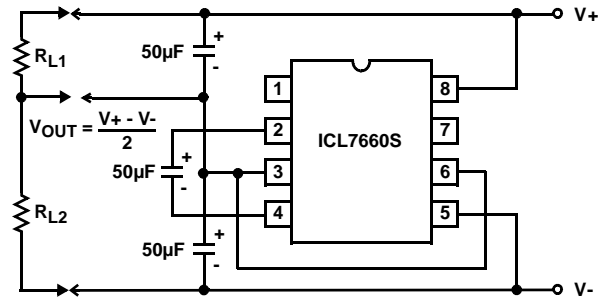
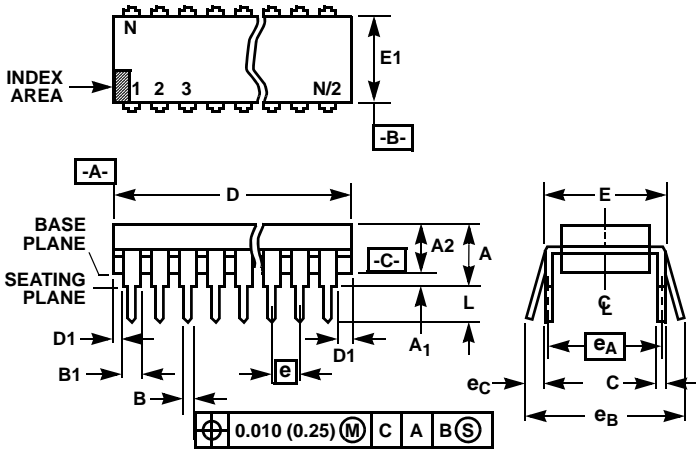

FIGURE 19. SPLITTING A SUPPLY IN HALF

Regulated Negative Voltage Supply

In some cases, the output impedance of the ICL7660S can be a problem, particularly if the load current varies substantially. The circuit of Figure 23 can be used to overcome this by controlling the input voltage, via an ICL7611 low-power CMOS op amp, in such a way as to maintain a nearly constant output voltage. Direct feedback is inadvisable, since the ICL7660S's output does not respond instantaneously to change in input, but only after the switching delay. The circuit shown supplies enough delay to accommodate the ICL7660S, while maintaining adequate feedback. An increase in pump and storage capacitors is desirable, and the values shown provides an output impedance of less than 5Ω to a load of 10mA.

Dual-In-Line Plastic Packages (PDIP)



NOTES:

- Controlling Dimensions: INCH. In case of conflict between English and Metric dimensions, the inch dimensions control.
- Dimensioning and tolerancing per ANSI Y14.5M-1982.
- Symbols are defined in the "MO Series Symbol List" in Section 2.2 of Publication No. 95.
- Dimensions A, A1 and L are measured with the package seated in JEDEC seating plane gauge GS-3.
- D, D1, and E1 dimensions do not include mold flash or protrusions. Mold flash or protrusions shall not exceed 0.010 inch (0.25mm).
- E and e_A are measured with the leads constrained to be perpendicular to datum $-C-$.
- e_B and e_C are measured at the lead tips with the leads unconstrained. e_C must be zero or greater.
- B1 maximum dimensions do not include dambar protrusions. Dambar protrusions shall not exceed 0.010 inch (0.25mm).
- N is the maximum number of terminal positions.
- Corner leads (1, N, N/2 and N/2 + 1) for E8.3, E16.3, E18.3, E28.3, E42.6 will have a B1 dimension of 0.030 - 0.045 inch (0.76 - 1.14mm).

E8.3 (JEDEC MS-001-BA ISSUE D)
8 LEAD DUAL-IN-LINE PLASTIC PACKAGE

SYMBOL	INCHES		MILLIMETERS		NOTES
	MIN	MAX	MIN	MAX	
A	-	0.210	-	5.33	4
A1	0.015	-	0.39	-	4
A2	0.115	0.195	2.93	4.95	-
B	0.014	0.022	0.356	0.558	-
B1	0.045	0.070	1.15	1.77	8, 10
C	0.008	0.014	0.204	0.355	-
D	0.355	0.400	9.01	10.16	5
D1	0.005	-	0.13	-	5
E	0.300	0.325	7.62	8.25	6
E1	0.240	0.280	6.10	7.11	5
e	0.100 BSC		2.54 BSC		-
e_A	0.300 BSC		7.62 BSC		6
e_B	-	0.430	-	10.92	7
L	0.115	0.150	2.93	3.81	4
N	8		8		9

Rev. 0 12/93

Small Outline Plastic Packages (SOIC)

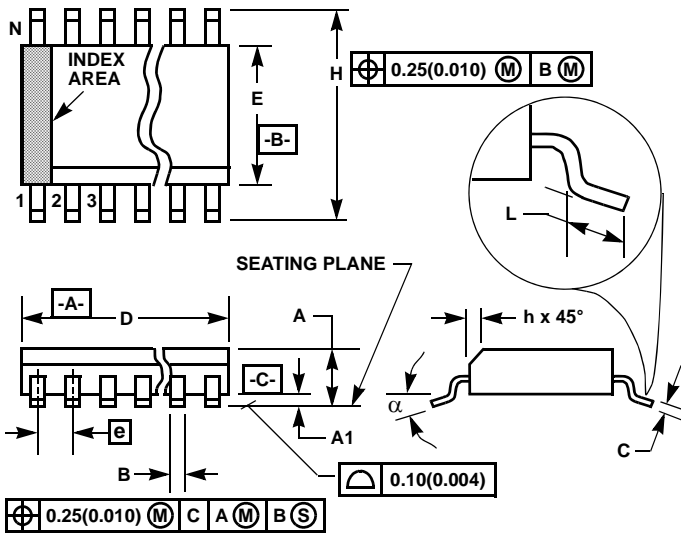

M8.15 (JEDEC MS-012-AA ISSUE C)
8 LEAD NARROW BODY SMALL OUTLINE PLASTIC PACKAGE

SYMBOL	INCHES		MILLIMETERS		NOTES
	MIN	MAX	MIN	MAX	
A	0.0532	0.0688	1.35	1.75	-
A1	0.0040	0.0098	0.10	0.25	-
B	0.013	0.020	0.33	0.51	9
C	0.0075	0.0098	0.19	0.25	-
D	0.1890	0.1968	4.80	5.00	3
E	0.1497	0.1574	3.80	4.00	4
e	0.050 BSC		1.27 BSC		-
H	0.2284	0.2440	5.80	6.20	-
h	0.0099	0.0196	0.25	0.50	5
L	0.016	0.050	0.40	1.27	6
N	8		8		7
α	0°	8°	0°	8°	-

NOTES:

1. Symbols are defined in the "MO Series Symbol List" in Section 2.2 of Publication Number 95.
2. Dimensioning and tolerancing per ANSI Y14.5M-1982.
3. Dimension "D" does not include mold flash, protrusions or gate burrs. Mold flash, protrusion and gate burrs shall not exceed 0.15mm (0.006 inch) per side.
4. Dimension "E" does not include interlead flash or protrusions. Interlead flash and protrusions shall not exceed 0.25mm (0.010 inch) per side.
5. The chamfer on the body is optional. If it is not present, a visual index feature must be located within the crosshatched area.
6. "L" is the length of terminal for soldering to a substrate.
7. "N" is the number of terminal positions.
8. Terminal numbers are shown for reference only.
9. The lead width "B", as measured 0.36mm (0.014 inch) or greater above the seating plane, shall not exceed a maximum value of 0.61mm (0.024 inch).
10. Controlling dimension: MILLIMETER. Converted inch dimensions are not necessarily exact.

Rev. 1 6/05

All Intersil U.S. products are manufactured, assembled and tested utilizing ISO9000 quality systems. Intersil Corporation's quality certifications can be viewed at www.intersil.com/design/quality

Intersil products are sold by description only. Intersil Corporation reserves the right to make changes in circuit design, software and/or specifications at any time without notice. Accordingly, the reader is cautioned to verify that data sheets are current before placing orders. Information furnished by Intersil is believed to be accurate and reliable. However, no responsibility is assumed by Intersil or its subsidiaries for its use; nor for any infringements of patents or other rights of third parties which may result from its use. No license is granted by implication or otherwise under any patent or patent rights of Intersil or its subsidiaries.

For information regarding Intersil Corporation and its products, see www.intersil.com