

- **Single Chip With Easy Interface Between UART and Serial-Port Connector of IBM™ PC/AT and Compatibles**
- **Meets or Exceeds the Requirements of ANSI Standard TIA/EIA-232-F and ITU Recommendation V.28**
- **Designed to Support Data Rates up to 120 kbit/s**
- **Pinout Compatible With SN75C185 and SN75185**
- **Package Options Include Plastic Small-Outline (DW), Shrink Small-Outline (DB), and Thin Shrink Small-Outline (PW) Packages, and DIPs (N)**

**DB, DW, N, OR PW PACKAGE
(TOP VIEW)**

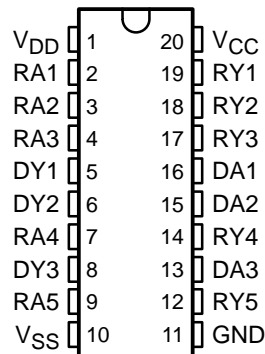

description

The GD75232 combines three drivers and five receivers from the Texas Instruments trade-standard SN75188 and SN75189 bipolar quadruple drivers and receivers, respectively. The pinout matches the flow-through design of the SN75C185 to decrease the part count, reduce the board space required, and allow easy interconnection of the UART and serial-port connector of an IBM™ PC/AT and compatibles. The bipolar circuits and processing of the GD75232 provide a rugged, low-cost solution for this function at the expense of quiescent power and external passive components relative to the SN75C185.

The GD75232 complies with the requirements of the TIA/EIA-232-F and ITU (formerly CCITT) V.28 standards. These standards are for data interchange between a host computer and a peripheral at signaling rates up to 20 kbit/s. The switching speeds of the GD75232 are fast enough to support rates up to 120 kbit/s with lower capacitive loads (shorter cables). Interoperability at the higher signaling rates cannot be expected unless the designer has design control of the cable and the interface circuits at both ends. For interoperability at signaling rates up to 120 kbit/s, use of ANSI TIA/EIA-423-B (ITU V.10) and TIA/EIA-422-B (ITU V.11) standards is recommended.

The GD75232 is characterized for operation over the temperature range of 0°C to 70°C.

AVAILABLE OPTIONS

T _A	PACKAGED DEVICES			
	PLASTIC SHRINK SMALL OUTLINE (DB)	PLASTIC SMALL OUTLINE (DW)	PLASTIC THIN SHRINK SMALL OUTLINE (PW)	PLASTIC DIP (N)
0°C to 70°C	GD75232DBR	GD75232DW	GD75232PWR	GD75232N

The DB and PW packages are only available taped and reeled. The DW package is also available taped and reeled. Add the suffix R to device type (e.g., GD75232DWR).



Please be aware that an important notice concerning availability, standard warranty, and use in critical applications of Texas Instruments semiconductor products and disclaimers thereto appears at the end of this data sheet.

IBM is a trademark of International Business Machines Corporation.

PRODUCTION DATA information is current as of publication date. Products conform to specifications per the terms of Texas Instruments standard warranty. Production processing does not necessarily include testing of all parameters.



GD75232 MULTIPLE RS-232 DRIVERS AND RECEIVERS

SLLS206E – MAY 1995 – REVISED NOVEMBER 2001

logic diagram (positive logic)

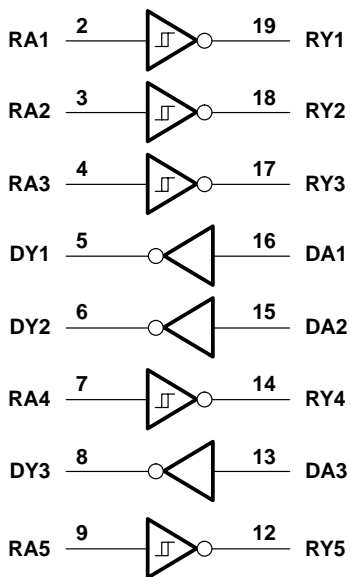

schematic (each driver)

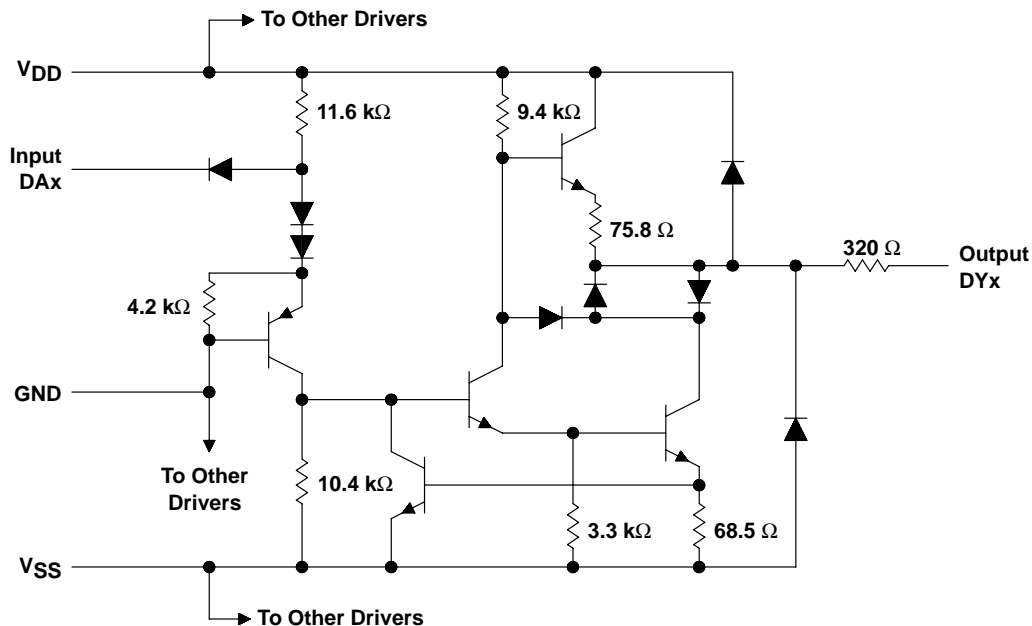

Resistor values shown are nominal.



schematic (each receiver)

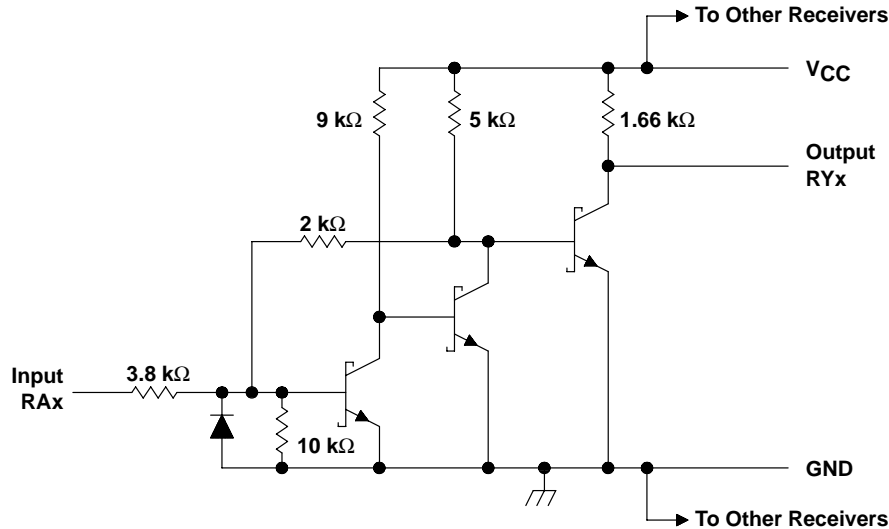

Resistor values shown are nominal.

absolute maximum ratings over operating free-air temperature range (unless otherwise noted)†

Supply voltage (see Note 1): V_{CC}	10 V
V_{DD}	15 V
V_{SS}	-15 V
Input voltage range, V_I : Driver	-15 V to 7 V
Receiver	-30 V to 30 V
Driver output voltage range, V_O	-15 V to 15 V
Receiver low-level output current, I_{OL}	20 mA
Package thermal impedance, θ_{JA} (see Note 2): DB package	70°C/W
DW package	58°C/W
N package	69°C/W
PW package	83°C/W
Lead temperature 1,6 mm (1/16 inch) from case for 10 seconds	260°C
Storage temperature range, T_{Stg}	-65°C to 150°C

† Stresses beyond those listed under "absolute maximum ratings" may cause permanent damage to the device. These are stress ratings only, and functional operation of the device at these or any other conditions beyond those indicated under "recommended operating conditions" is not implied. Exposure to absolute-maximum-rated conditions for extended periods may affect device reliability.

- NOTES: 1. All voltages are with respect to the network ground terminal.
2. The package thermal impedance is calculated in accordance with JESD 51-7.

GD75232

MULTIPLE RS-232 DRIVERS AND RECEIVERS

SLLS206E – MAY 1995 – REVISED NOVEMBER 2001

recommended operating conditions

		MIN	NOM	MAX	UNIT
V _{DD}	Supply voltage	7.5	5	5.25	V
V _{SS}	Supply voltage	-7.5	-9	-15	V
V _{CC}	Supply voltage	4.5	5	5.5	V
V _{IH}	High-level input voltage (driver only)	1.9			V
V _{IL}	Low-level input voltage (driver only)			0.8	V
I _{OH}	High-level output current	Driver		-6	mA
		Receiver		-0.5	
I _{OL}	Low-level output current	Driver		6	mA
		Receiver		16	
T _A	Operating free-air temperature	0		70	°C

supply currents over recommended operating free-air temperature range

PARAMETER	TEST CONDITIONS		MIN	MAX	UNIT
I _{DD} Supply current from V _{DD}	All inputs at 1.9 V, No load	V _{DD} = 9 V, V _{SS} = -9 V		15	mA
		V _{DD} = 12 V, V _{SS} = -12 V		19	
		V _{DD} = 15 V, V _{SS} = -15 V		25	
	All inputs at 0.8 V, No load	V _{DD} = 9 V, V _{SS} = -9 V		4.5	
		V _{DD} = 12 V, V _{SS} = -12 V		5.5	
		V _{DD} = 15 V, V _{SS} = -15 V		9	
I _{SS} Supply current from V _{SS}	All inputs at 1.9 V, No load	V _{DD} = 9 V, V _{SS} = -9 V		-15	mA
		V _{DD} = 12 V, V _{SS} = -12 V		-19	
		V _{DD} = 15 V, V _{SS} = -15 V		-25	
	All inputs at 0.8 V, No load	V _{DD} = 9 V, V _{SS} = -9 V		-3.2	
		V _{DD} = 12 V, V _{SS} = -12 V		-3.2	
		V _{DD} = 15 V, V _{SS} = -15 V		-3.2	
I _{CC} Supply current from V _{CC}	All inputs at 5 V, No load,	V _{CC} = 5 V		30	mA



DRIVER SECTION

electrical characteristics over recommended operating free-air temperature range, $V_{DD} = 9\text{ V}$, $V_{SS} = -9\text{ V}$, $V_{CC} = 5\text{ V}$ (unless otherwise noted)

PARAMETER		TEST CONDITIONS			MIN	TYP	MAX	UNIT
V_{OH}	High-level output voltage	$V_{IL} = 0.8\text{ V}$,	$R_L = 3\text{ k}\Omega$,	See Figure 1	6	7.5		V
V_{OL}	Low-level output voltage (see Note 3)	$V_{IH} = 1.9\text{ V}$,	$R_L = 3\text{ k}\Omega$,	See Figure 1		-7.5	-6	V
I_{IH}	High-level input current	$V_I = 5\text{ V}$,		See Figure 2			10	μA
I_{IL}	Low-level input current	$V_I = 0$,		See Figure 2			-1.6	mA
$I_{OS(H)}$	High-level short-circuit output current (see Note 4)	$V_{IL} = 0.8\text{ V}$,	$V_O = 0$,	See Figure 1	-4.5	-12	-19.5	mA
$I_{OS(L)}$	Low-level short-circuit output current	$V_{IH} = 2\text{ V}$,	$V_O = 0$,	See Figure 1	4.5	12	19.5	mA
r_O	Output resistance (see Note 5)	$V_{CC} = V_{DD} = V_{SS} = 0$,		$V_O = -2\text{ V to } 2\text{ V}$	300			Ω

- NOTES: 3. The algebraic convention, where the more positive (less negative) limit is designated as maximum, is used in this data sheet for logic levels only (e.g., if -10 V is maximum, the typical value is a more negative voltage).
 4. Output short-circuit conditions must maintain the total power dissipation below absolute maximum ratings.
 5. Test conditions are those specified by TIA/EIA-232-F and as listed above.

switching characteristics, $V_{CC} = 5\text{ V}$, $V_{DD} = 12\text{ V}$, $V_{SS} = -12\text{ V}$, $T_A = 25^\circ\text{C}$

PARAMETER		TEST CONDITIONS			MIN	TYP	MAX	UNIT
t_{PLH}	Propagation delay time, low- to high-level output	$R_L = 3\text{ k}\Omega$ to $7\text{ k}\Omega$,	$C_L = 15\text{ pF}$,	See Figure 3		315	500	ns
t_{PHL}	Propagation delay time, high- to low-level output	$R_L = 3\text{ k}\Omega$ to $7\text{ k}\Omega$,	$C_L = 15\text{ pF}$,	See Figure 3		75	175	ns
t_{TLH}	Transition time, low- to high-level output	$R_L = 3\text{ k}\Omega$ to $7\text{ k}\Omega$	$C_L = 15\text{ pF}$,	See Figure 3		60	100	ns
			$C_L = 2500\text{ pF}$,	See Figure 3 and Note 6		1.7	2.5	μs
t_{THL}	Transition time, high- to low-level output	$R_L = 3\text{ k}\Omega$ to $7\text{ k}\Omega$	$C_L = 15\text{ pF}$,	See Figure 3		40	75	ns
			$C_L = 2500\text{ pF}$,	See Figure 3 and Note 6		1.5	2.5	μs

NOTE 6: Measured between $\pm 3\text{-V}$ and $\pm 3\text{-V}$ points of the output waveform (TIA/EIA-232-F conditions); all unused inputs are tied either high or low.

GD75232

MULTIPLE RS-232 DRIVERS AND RECEIVERS

SLLS206E – MAY 1995 – REVISED NOVEMBER 2001

RECEIVER SECTION

electrical characteristics over recommended operating conditions (unless otherwise noted)

PARAMETER		TEST CONDITIONS	MIN	TYP†	MAX	UNIT
V _{IT+}	Positive-going input threshold voltage	T _A = 25°C, See Figure 5	1.75	1.9	2.3	V
		T _A = 0°C to 70°C, See Figure 5	1.55		2.3	
V _{IT-}	Negative-going input threshold voltage		0.75	0.97	1.25	V
V _{hys}	Input hysteresis voltage (V _{IT+} – V _{IT-})		0.5			V
V _{OH}	High-level output voltage	I _{OH} = –0.5 mA V _{IH} = 0.75 V Inputs open	2.6	4	5	V
			2.6			
V _{OL}	Low-level input voltage	I _{OL} = 10 mA, V _I = 3 V		0.2	0.45	V
I _{IH}	High-level input current	V _I = 25 V, See Figure 5	3.6		8.3	mA
		V _I = 3 V, See Figure 5	0.43			
I _{IL}	Low-level output current	V _I = –25 V, See Figure 5	–3.6		–8.3	mA
		V _I = –3 V, See Figure 5	–0.43			
I _{OS}	Short-circuit output current	See Figure 4		–3.4	–12	mA

† All typical values are at T_A = 25°C, V_{CC} = 5 V, V_{DD} = 9 V, and V_{SS} = –9 V.

switching characteristics, V_{CC} = 5 V, V_{DD} = 12 V, V_{SS} = –12 V, T_A = 25°C

PARAMETER		TEST CONDITIONS	MIN	TYP	MAX	UNIT
t _{PLH}	Propagation delay time, low- to high-level output	C _L = 50 pF, R _L = 5 kΩ, See Figure 6		107	250	ns
t _{PHL}	Propagation delay time, high- to low-level output			42	150	ns
t _{TLH}	Transition time, low- to high-level output			175	350	ns
t _{THL}	Transition time, high- to low-level output			16	60	ns
t _{PLH}	Propagation delay time, low- to high-level output	C _L = 15 pF, R _L = 1.5 kΩ, See Figure 6		100	160	ns
t _{PHL}	Propagation delay time, high- to low-level output			60	100	ns
t _{TLH}	Transition time, low- to high-level output			90	175	ns
t _{THL}	Transition time, high- to low-level output			15	50	ns



PARAMETER MEASUREMENT INFORMATION

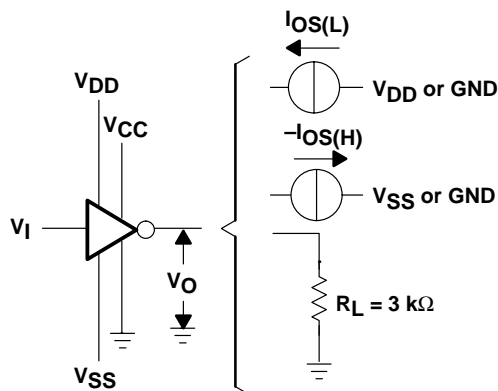

Figure 1. Driver Test Circuit for V_{OH} , V_{OL} , $I_{OS(H)}$, and $I_{OS(L)}$

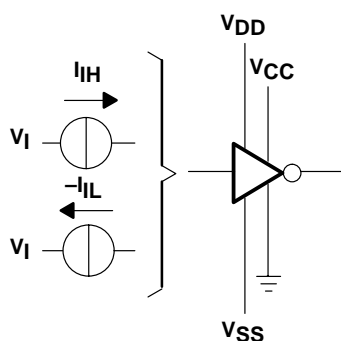
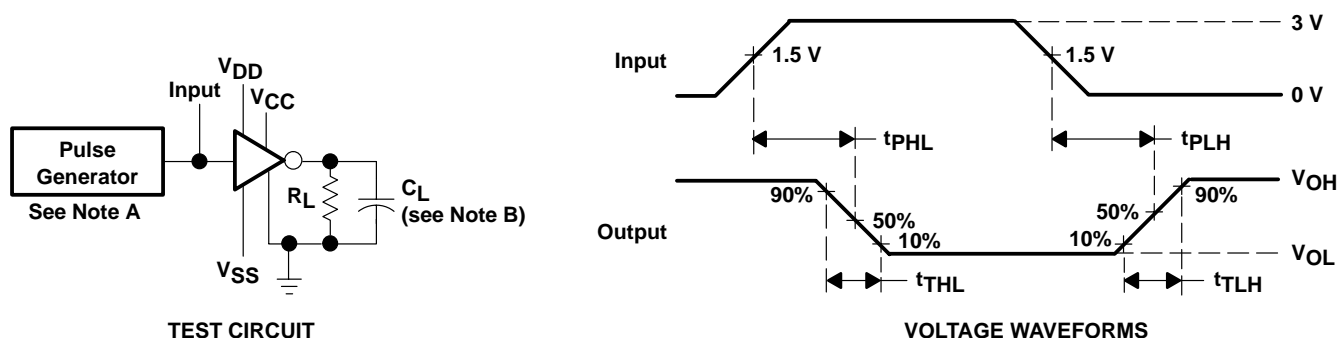

Figure 2. Driver Test Circuit for I_{IH} and I_{IL}



NOTES: A. The pulse generator has the following characteristics: $t_w = 25\ \mu\text{s}$, $\text{PRR} = 20\ \text{kHz}$, $Z_O = 50\ \Omega$, $t_r = t_f < 50\ \text{ns}$.
 B. C_L includes probe and jig capacitance.

Figure 3. Driver Test Circuit and Voltage Waveforms

PARAMETER MEASUREMENT INFORMATION

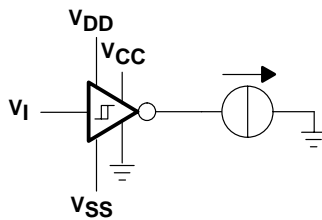

Figure 4. Receiver Test Circuit for I_{OS}

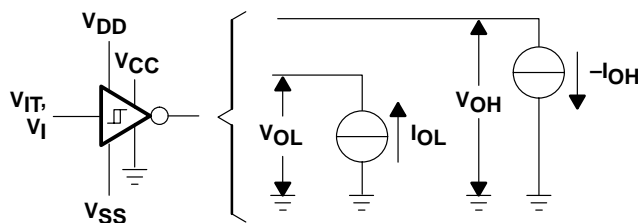
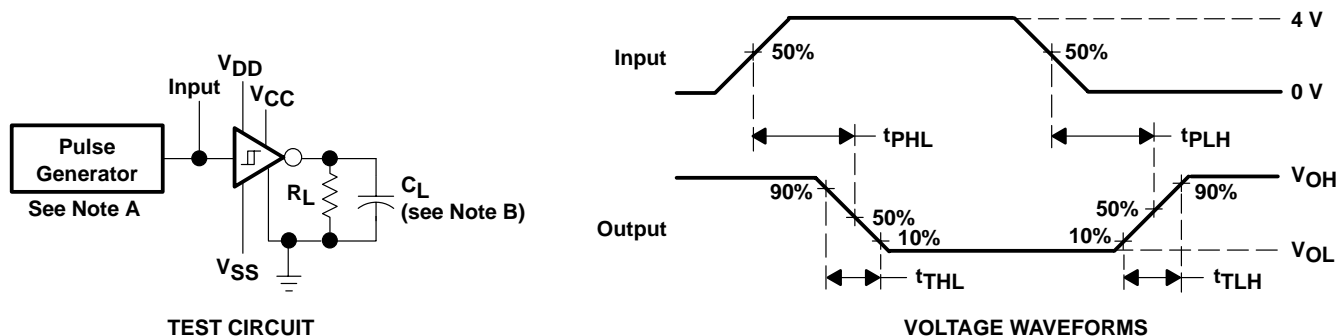

Figure 5. Receiver Test Circuit for V_{IT} , V_{OH} , and V_{OL}



NOTES: A. The pulse generator has the following characteristics: $t_w = 25 \mu s$, $PRR = 20 \text{ kHz}$, $Z_O = 50 \Omega$, $t_r = t_f < 50 \text{ ns}$.
 B. C_L includes probe and jig capacitance.

Figure 6. Receiver Propagation and Transition Times

TYPICAL CHARACTERISTICS

DRIVER SECTION

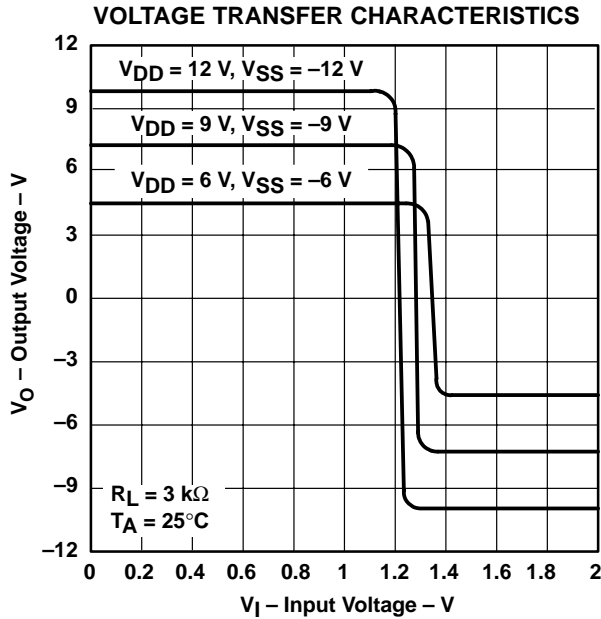

Figure 7

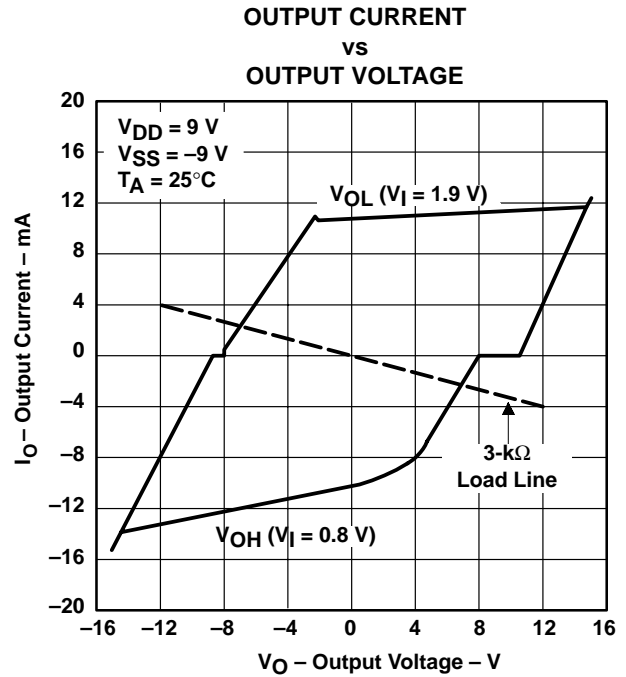

Figure 8

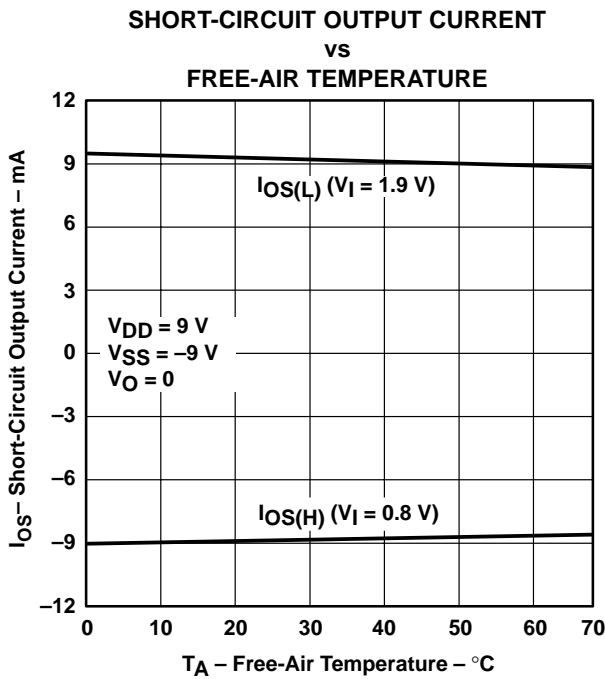

Figure 9

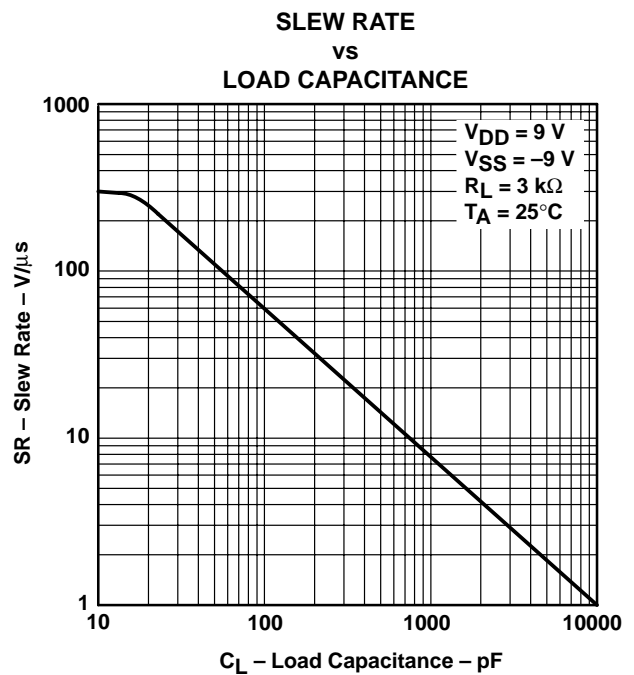

Figure 10

TYPICAL CHARACTERISTICS

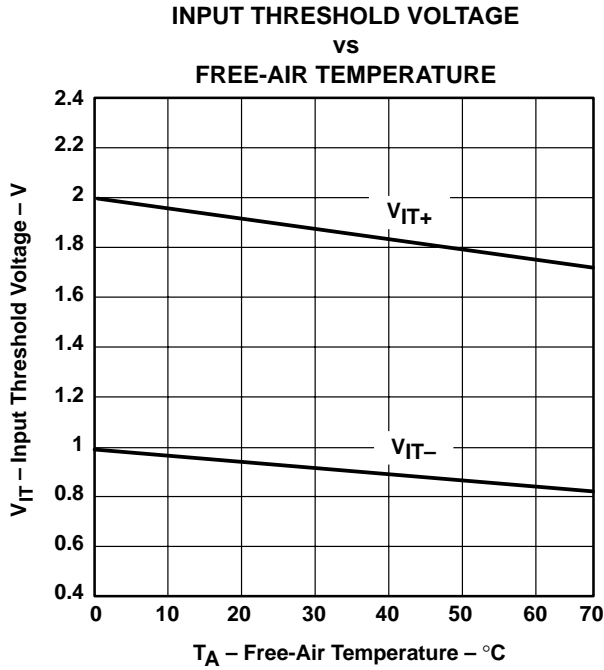

Figure 11

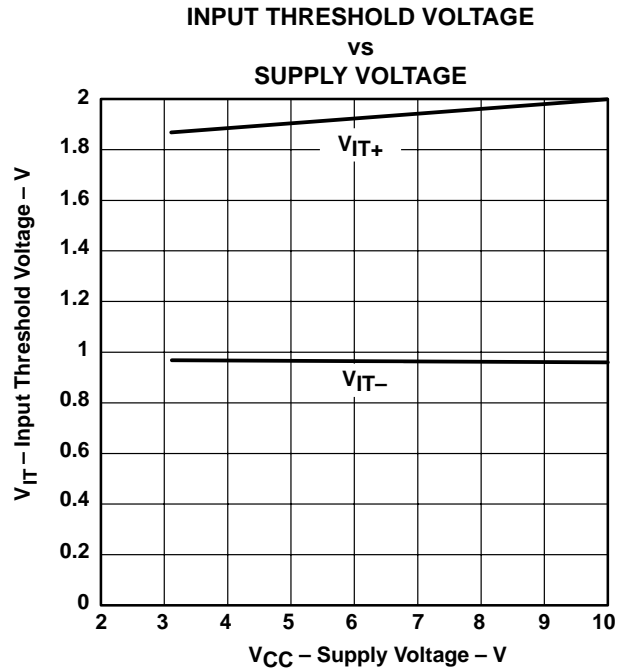
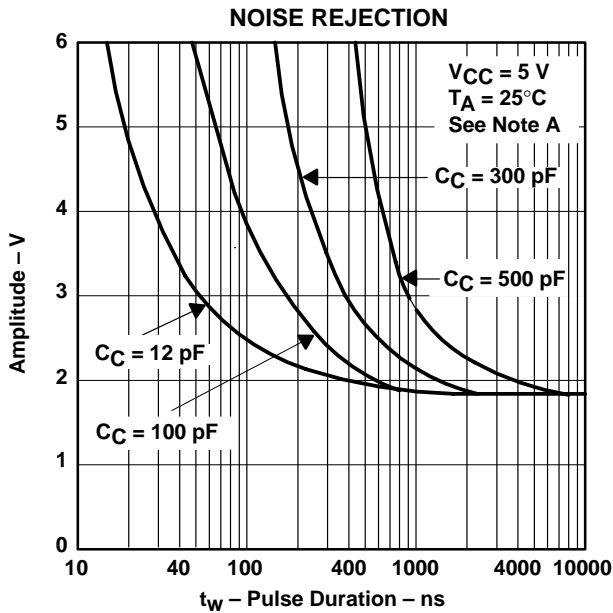

Figure 12



NOTE A: This figure shows the maximum amplitude of a positive-going pulse that, starting from 0 V, does not cause a change of the output level.

Figure 13

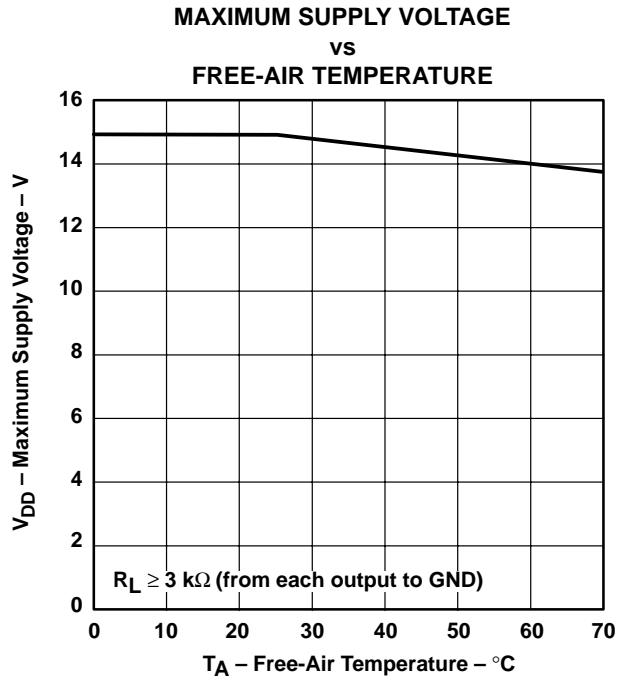

Figure 14

APPLICATION INFORMATION

Diodes placed in series with the V_{DD} and V_{SS} leads protect the GD75232 in the fault condition in which the device outputs are shorted to ± 15 V and the power supplies are at low and provide low-impedance paths to ground (see Figure 15).

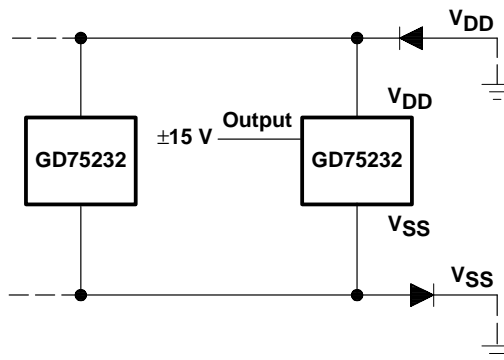

Figure 15. Power-Supply Protection to Meet Power-Off Fault Conditions of TIA/EIA-232-F

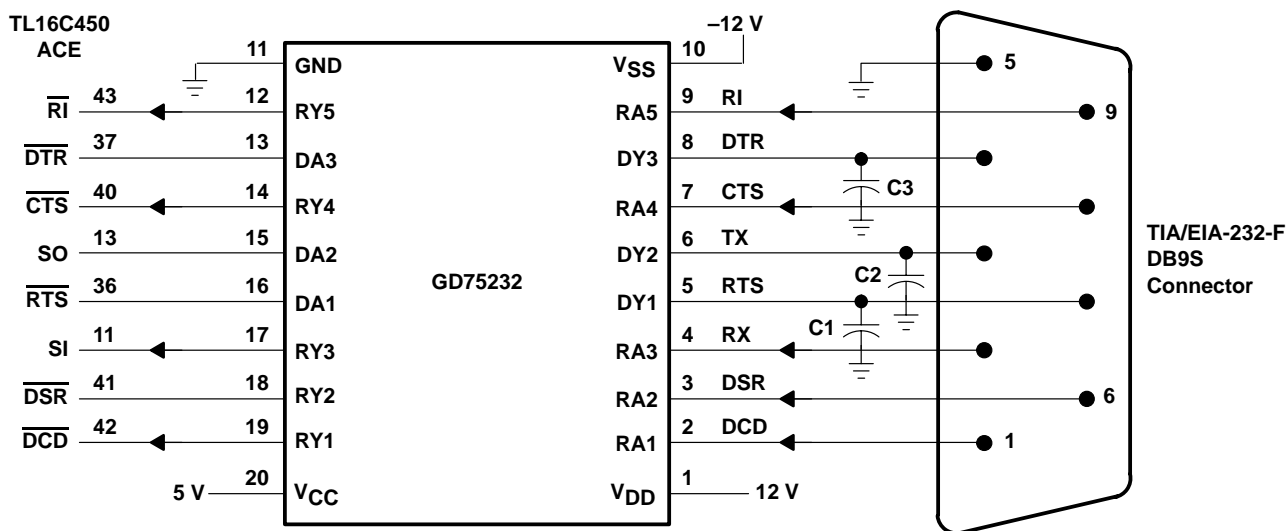

Figure 16. Typical Connection

IMPORTANT NOTICE

Texas Instruments Incorporated and its subsidiaries (TI) reserve the right to make corrections, modifications, enhancements, improvements, and other changes to its products and services at any time and to discontinue any product or service without notice. Customers should obtain the latest relevant information before placing orders and should verify that such information is current and complete. All products are sold subject to TI's terms and conditions of sale supplied at the time of order acknowledgment.

TI warrants performance of its hardware products to the specifications applicable at the time of sale in accordance with TI's standard warranty. Testing and other quality control techniques are used to the extent TI deems necessary to support this warranty. Except where mandated by government requirements, testing of all parameters of each product is not necessarily performed.

TI assumes no liability for applications assistance or customer product design. Customers are responsible for their products and applications using TI components. To minimize the risks associated with customer products and applications, customers should provide adequate design and operating safeguards.

TI does not warrant or represent that any license, either express or implied, is granted under any TI patent right, copyright, mask work right, or other TI intellectual property right relating to any combination, machine, or process in which TI products or services are used. Information published by TI regarding third-party products or services does not constitute a license from TI to use such products or services or a warranty or endorsement thereof. Use of such information may require a license from a third party under the patents or other intellectual property of the third party, or a license from TI under the patents or other intellectual property of TI.

Reproduction of information in TI data books or data sheets is permissible only if reproduction is without alteration and is accompanied by all associated warranties, conditions, limitations, and notices. Reproduction of this information with alteration is an unfair and deceptive business practice. TI is not responsible or liable for such altered documentation.

Resale of TI products or services with statements different from or beyond the parameters stated by TI for that product or service voids all express and any implied warranties for the associated TI product or service and is an unfair and deceptive business practice. TI is not responsible or liable for any such statements.

Mailing Address:

Texas Instruments
Post Office Box 655303
Dallas, Texas 75265