

THIS DRAWING IS THE PROPERTY OF FAIRCHILD SEMICONDUCTOR CORPORATION. NO USE THEREOF SHALL BE MADE OTHER THAN AS A REFERENCE FOR PROPOSALS AS SUBMITTED TO FAIRCHILD SEMICONDUCTOR CORPORATION FOR ASSETS TO BE EXECUTED IN CONFORMITY WITH SUCH PROPOSALS UNLESS THE CONSENT OF SAID FAIRCHILD SEMICONDUCTOR CORPORATION HAS PREVIOUSLY BEEN OBTAINED. NO PART OF THIS DRAWING SHALL BE COPIED OR DUPLICATED OR ITS CONTENTS DISCLOSED, THE INFORMATION CONTAINED ON THIS DRAWING IS CONFIDENTIAL AND PROPRIETARY.

REVISIONS				
LR	DESCRIPTION	ECN	DATE	BY/APPRO
A	RELEASE TO DOCUMENT CONTROL	CB22702	23JUL2002	MRG/EAC
B	CHG DWG TITLE FR "JEDEC MO229, 3mm SQUARE" TO "DUAL, NON JEDEC VERSION, 3.3mm SQUARE, CHG NOTE A) FR JEDEC MO229 TO NO JEDEC STANDARD REF."	CB23902	2AUG2002	MRG/EAC
1	CHG DWG # FROM MLP08L TO MLP08L TO ELIMINATE DUPLICATION IN DRAWING NUMBER ASSIGNMENT. REVISION LEVEL CHANGED TO NUMBER	ECN-MKT-MLP08L1	14/09/06	H.ALLEN

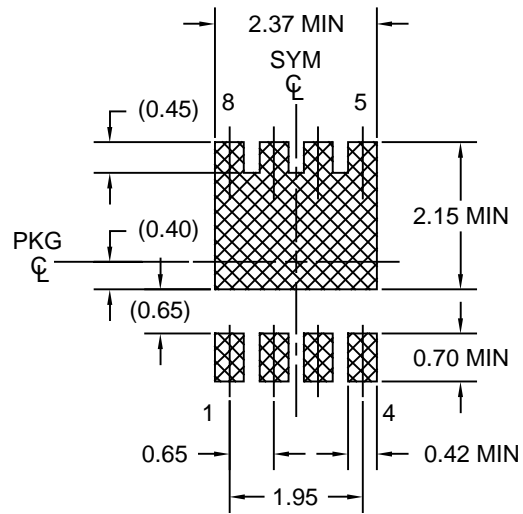

LAND PATTERN RECOMMENDATION

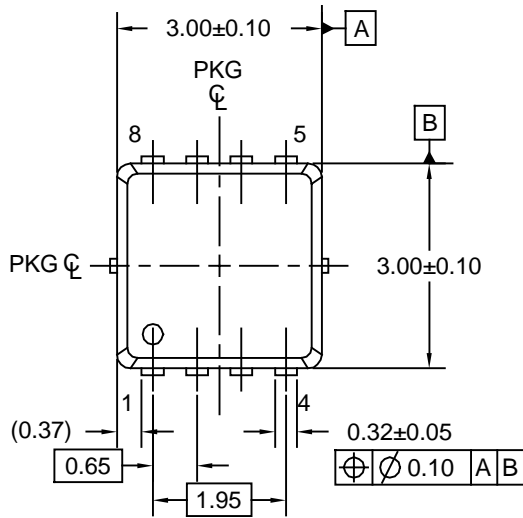
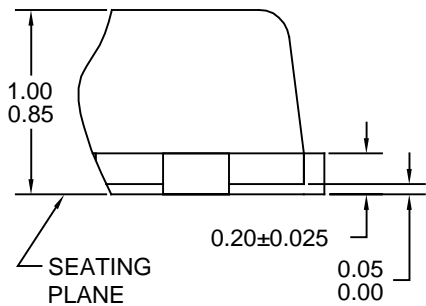
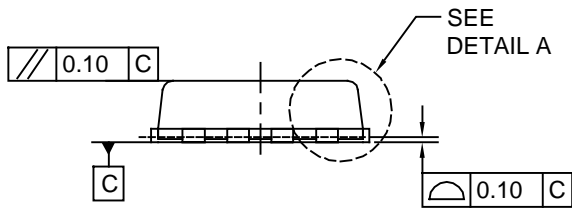

DETAIL A
SCALE: 3:1

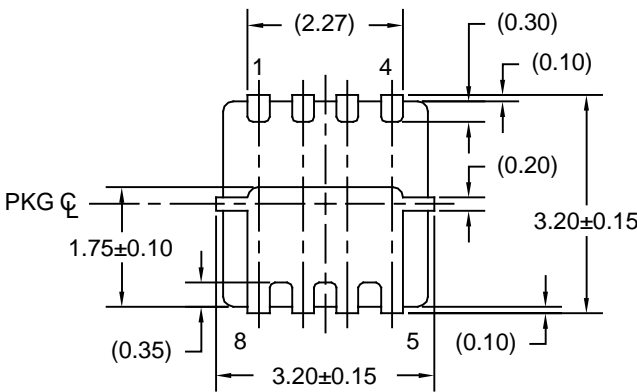

- NOTES: UNLESS OTHERWISE SPECIFIED
- A) NO JEDEC STANDARD REFERENCE AS OF JULY 2002.
 - B) ALL DIMENSIONS ARE IN MILLIMETERS.
 - C) DIMENSIONS DO NOT INCLUDE BURRS OR MOLD FLASH.
 - D) DIMENSIONING AND TOLERANCING PER ASME Y14.5M-1994.

MLP08Lrev1

APPROVALS	DATE	FAIRCHILD SEMICONDUCTOR™	
DRAWN: H.ALLEN	14/9/06	PENANG MALAYSIA	
CHECKED: J. CHAN		8LD, MLP, DUAL, NON JEDEC VERSION, MICROFET, 3.3 mm SQUARE	
APPROVED:		SCALE: 1:1	REV: 1
		FORMERLY: N/A	SHEET: 1 OF 1