

# ***eZ430-RF2500 Development Tool***

# *User's Guide*

## EVALUATION BOARD/KIT IMPORTANT NOTICE

Texas Instruments (TI) provides the enclosed product(s) under the following conditions:

This evaluation board/kit is intended for use for **ENGINEERING DEVELOPMENT, DEMONSTRATION, OR EVALUATION PURPOSES ONLY** and is not considered by TI to be a finished end-product fit for general consumer use. Persons handling the product(s) must have electronics training and observe good engineering practice standards. As such, the goods being provided are not intended to be complete in terms of required design-, marketing-, and/or manufacturing-related protective considerations, including product safety and environmental measures typically found in end products that incorporate such semiconductor components or circuit boards. This evaluation board/kit does not fall within the scope of the European Union directives regarding electromagnetic compatibility, restricted substances (RoHS), recycling (WEEE), FCC, CE or UL, and therefore may not meet the technical requirements of these directives or other related directives.

Should this evaluation board/kit not meet the specifications indicated in the User's Guide, the board/kit may be returned within 30 days from the date of delivery for a full refund. THE FOREGOING WARRANTY IS THE EXCLUSIVE WARRANTY MADE BY SELLER TO BUYER AND IS IN LIEU OF ALL OTHER WARRANTIES, EXPRESSED, IMPLIED, OR STATUTORY, INCLUDING ANY WARRANTY OF MERCHANTABILITY OR FITNESS FOR ANY PARTICULAR PURPOSE.

The user assumes all responsibility and liability for proper and safe handling of the goods. Further, the user indemnifies TI from all claims arising from the handling or use of the goods. Due to the open construction of the product, it is the user's responsibility to take any and all appropriate precautions with regard to electrostatic discharge.

EXCEPT TO THE EXTENT OF THE INDEMNITY SET FORTH ABOVE, NEITHER PARTY SHALL BE LIABLE TO THE OTHER FOR ANY INDIRECT, SPECIAL, INCIDENTAL, OR CONSEQUENTIAL DAMAGES.

TI currently deals with a variety of customers for products, and therefore our arrangement with the user **is not exclusive**.

TI assumes **no liability for applications assistance, customer product design, software performance, or infringement of patents or services described herein**.

Please read the User's Guide and, specifically, the Warnings and Restrictions notice in the User's Guide prior to handling the product. This notice contains important safety information about temperatures and voltages. For additional information on TI's environmental and/or safety programs, please contact the TI application engineer or visit [www.ti.com/esh](http://www.ti.com/esh).

No license is granted under any patent right or other intellectual property right of TI covering or relating to any machine, process, or combination in which such TI products or services might be or are used.

### FCC Warning

This evaluation board/kit is intended for use for **ENGINEERING DEVELOPMENT, DEMONSTRATION, OR EVALUATION PURPOSES ONLY** and is not considered by TI to be a finished end-product fit for general consumer use. It generates, uses, and can radiate radio frequency energy and has not been tested for compliance with the limits of computing devices pursuant to part 15 of FCC rules, which are designed to provide reasonable protection against radio frequency interference. Operation of this equipment in other environments may cause interference with radio communications, in which case the user at his own expense will be required to take whatever measures may be required to correct this interference.

### EVM WARNINGS AND RESTRICTIONS

It is important to operate this EVM within the input voltage range of 1.8 V to 3.6 V and the output voltage range of 1.8 V to 3.6 V.

Exceeding the specified input range may cause unexpected operation and/or irreversible damage to the EVM. If there are questions concerning the input range, please contact a TI field representative prior to connecting the input power.

Applying loads outside of the specified output range may result in unintended operation and/or possible permanent damage to the EVM. Please consult the EVM User's Guide prior to connecting any load to the EVM output. If there is uncertainty as to the load specification, please contact a TI field representative.

During normal operation, some circuit components may have case temperatures greater than 60 C. The EVM is designed to operate properly with certain components above 60 C as long as the input and output ranges are maintained. These components include but are not limited to linear regulators, switching transistors, pass transistors, and current sense resistors. These types of devices can be identified using the EVM schematic located in the EVM User's Guide. When placing measurement probes near these devices during operation, please be aware that these devices may be very warm to the touch.

Mailing Address: Texas Instruments, Post Office Box 655303, Dallas, Texas 75265

Copyright © 2007, Texas Instruments Incorporated

## IMPORTANT NOTICE

Texas Instruments Incorporated and its subsidiaries (TI) reserve the right to make corrections, modifications, enhancements, improvements, and other changes to its products and services at any time and to discontinue any product or service without notice. Customers should obtain the latest relevant information before placing orders and should verify that such information is current and complete. All products are sold subject to TI's terms and conditions of sale supplied at the time of order acknowledgment.

TI warrants performance of its hardware products to the specifications applicable at the time of sale in accordance with TI's standard warranty. Testing and other quality control techniques are used to the extent TI deems necessary to support this warranty. Except where mandated by government requirements, testing of all parameters of each product is not necessarily performed.

TI assumes no liability for applications assistance or customer product design. Customers are responsible for their products and applications using TI components. To minimize the risks associated with customer products and applications, customers should provide adequate design and operating safeguards.

TI does not warrant or represent that any license, either express or implied, is granted under any TI patent right, copyright, mask work right, or other TI intellectual property right relating to any combination, machine, or process in which TI products or services are used. Information published by TI regarding third-party products or services does not constitute a license from TI to use such products or services or a warranty or endorsement thereof. Use of such information may require a license from a third party under the patents or other intellectual property of the third party, or a license from TI under the patents or other intellectual property of TI.

Reproduction of TI information in TI data books or data sheets is permissible only if reproduction is without alteration and is accompanied by all associated warranties, conditions, limitations, and notices. Reproduction of this information with alteration is an unfair and deceptive business practice. TI is not responsible or liable for such altered documentation. Information of third parties may be subject to additional restrictions.

Resale of TI products or services with statements different from or beyond the parameters stated by TI for that product or service voids all express and any implied warranties for the associated TI product or service and is an unfair and deceptive business practice. TI is not responsible or liable for any such statements.

TI products are not authorized for use in safety-critical applications (such as life support) where a failure of the TI product would reasonably be expected to cause severe personal injury or death, unless officers of the parties have executed an agreement specifically governing such use. Buyers represent that they have all necessary expertise in the safety and regulatory ramifications of their applications, and acknowledge and agree that they are solely responsible for all legal, regulatory and safety-related requirements concerning their products and any use of TI products in such safety-critical applications, notwithstanding any applications-related information or support that may be provided by TI. Further, Buyers must fully indemnify TI and its representatives against any damages arising out of the use of TI products in such safety-critical applications.

TI products are neither designed nor intended for use in military/aerospace applications or environments unless the TI products are specifically designated by TI as military-grade or "enhanced plastic." Only products designated by TI as military-grade meet military specifications. Buyers acknowledge and agree that any such use of TI products which TI has not designated as military-grade is solely at the Buyer's risk, and that they are solely responsible for compliance with all legal and regulatory requirements in connection with such use.

TI products are neither designed nor intended for use in automotive applications or environments unless the specific TI products are designated by TI as compliant with ISO/TS 16949 requirements. Buyers acknowledge and agree that, if they use any non-designated products in automotive applications, TI will not be responsible for any failure to meet such requirements.

Following are URLs where you can obtain information on other Texas Instruments products and application solutions:

### Products

Amplifiers	<a href="http://amplifier.ti.com">amplifier.ti.com</a>
Data Converters	<a href="http://dataconverter.ti.com">dataconverter.ti.com</a>
DSP	<a href="http://dsp.ti.com">dsp.ti.com</a>
Interface	<a href="http://interface.ti.com">interface.ti.com</a>
Logic	<a href="http://logic.ti.com">logic.ti.com</a>
Power Mgmt	<a href="http://power.ti.com">power.ti.com</a>
Microcontrollers	<a href="http://microcontroller.ti.com">microcontroller.ti.com</a>
RFID	<a href="http://www.ti-rfid.com">www.ti-rfid.com</a>
Low Power	<a href="http://www.ti.com/lpw">www.ti.com/lpw</a>

### Applications

Audio	<a href="http://www.ti.com/audio">www.ti.com/audio</a>
Automotive	<a href="http://www.ti.com/automotive">www.ti.com/automotive</a>
Broadband	<a href="http://www.ti.com/broadband">www.ti.com/broadband</a>
Digital Control	<a href="http://www.ti.com/digitalcontrol">www.ti.com/digitalcontrol</a>
Military	<a href="http://www.ti.com/military">www.ti.com/military</a>
Optical Networking	<a href="http://www.ti.com/opticalnetwork">www.ti.com/opticalnetwork</a>
Security	<a href="http://www.ti.com/security">www.ti.com/security</a>
Telephony	<a href="http://www.ti.com/telephony">www.ti.com/telephony</a>
Video & Imaging	<a href="http://www.ti.com/video">www.ti.com/video</a>
Wireless	<a href="http://www.ti.com/wireless">www.ti.com/wireless</a>

Mailing Address: Texas Instruments, Post Office Box 655303, Dallas, Texas 75265

Copyright © 2007, Texas Instruments Incorporated

## ***If You Need Assistance***

Support for the MSP430 device and the eZ430-RF2500 is provided by the Texas Instruments [Product Information Center \(PIC\)](#). Contact information for the PIC can be found on the TI web site at [www.ti.com](http://www.ti.com). Additional device-specific information can be found on the MSP430 web site at [www.ti.com/msp430](http://www.ti.com/msp430) and [www.ti.com/ez430-rf](http://www.ti.com/ez430-rf).

### **Note: IAR Embedded Workbench Kickstart is supported by Texas Instruments**

Although IAR Embedded Workbench Kickstart is a product of IAR, Texas Instruments provides support for Kickstart. Therefore, please do not request support for Kickstart from IAR. Please consult all provided documentation with Kickstart before requesting assistance.

## ***We Would Like to Hear from You***

If you have any comments, feedbacks, or suggestions, please let us know by contacting us at [support@ti.com](mailto:support@ti.com).

# Contents

eZ430-RF2500 Development Tool .....	1
1. eZ430-RF2500 Overview. Wireless Made Easy. ....	2
2. Kit Contents, eZ430-RF2500.....	3
3. Developing with eZ430-RF2500T Target Board .....	4
4. Specifications.....	5
5. Supported Devices .....	6
6. MSP430 Application UART .....	6
7. Software Installation .....	7
8. Hardware Installation.....	7
9. SimpliciTI™ .....	8
10. Demo – MSP430 Sensor Monitor.....	8
10.1. Demo Hardware Setup.....	9
10.2. Demo Firmware Download.....	9
10.3. Demo Software GUI Setup.....	10
10.4. Demo Options.....	10
11. Suggested Reading .....	10
12. Frequently Asked Questions (FAQ) .....	11
13. eZ430-RF2500 Schematics.....	12
14. Detailed Hardware Install Guide.....	16

## 1. eZ430-RF2500 Overview. Wireless Made Easy.

The eZ430-RF2500 is a complete USB-based MSP430 wireless development tool providing all the hardware and software to evaluate the MSP430F2274 microcontroller and CC2500 2.4GHz wireless transceiver.

The eZ430-RF2500 uses the IAR Embedded Workbench Integrated Development Environment (IDE) or Code Composer Essentials (CCE) to write, download, and debug your application. The debugger is unobtrusive allowing the user to run an application at full speed with both hardware breakpoints and single stepping available while consuming no extra hardware resources.

The eZ430-RF2500T target board is an out-of-the box wireless system that may be used with the USB debugging interface, as a stand-alone system with or without external sensors, or may be incorporated into an existing design.

The new USB debugging interface enables eZ430-RF2500 to remotely send and receive data from your PC using the MSP430 Application UART.

eZ430-RF2500 features:

- USB debugging and programming interface featuring a driverless installation and application backchannel
- 21 available development pins
- Highly integrated, ultra-low-power MSP430 MCU with 16MHz performance
- Two general-purpose digital I/O pins connected to green and red LEDs for visual feedback
- Interruptible push button for user feedback
- Range up to 450ft at 10kbps

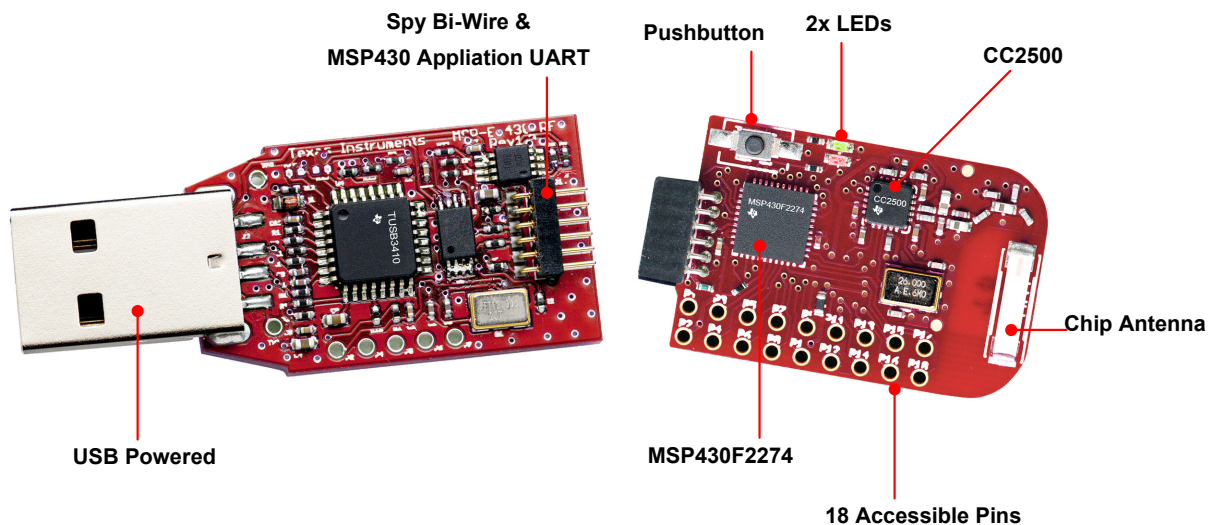

Figure 1. eZ430-RF2500

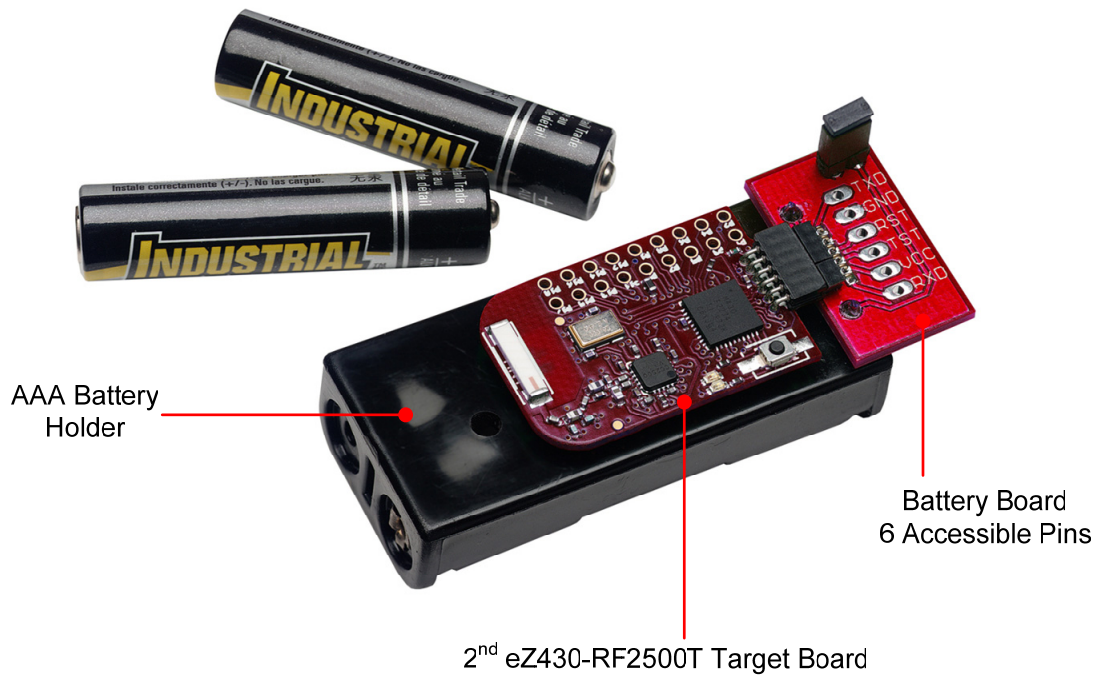

Figure 2. eZ430-RF2500 Battery Board

## 2. Kit Contents, eZ430-RF2500

- The hardware includes:
  - 2 eZ430-RF2500T target boards
  - 1 eZ430-RF USB debugging interface
  - 1 AAA battery pack with expansion board (batteries included)
- One MSP430 Development Tool CD-ROM containing documentation and new development software for eZ430-RF2500.
  - MSP430F2xx Family User's Guide, SLAU144
  - MSP-FET430 FLASH Emulation Tool User's Guide, SLAU138
  - eZ430-RF2500 User's Guide, SLAU227
  - Code Composer Essentials (CCE), SLAC063
  - IAR Embedded Workbench (Kickstart Version), SLAC050
  - eZ430-RF2500 Sensor Monitor (Code and Visualizer), SLAC139

**NOTE:** Please visit Texas Instrument's website for latest versions  
[www.ti.com/msp430](http://www.ti.com/msp430)

### 3. Developing with eZ430-RF2500T Target Board

The eZ430-RF2500 can be used as a stand-alone development tool. Additionally, the eZ430-RF2500T target board may also be detached from the debugging interface and integrated into another design by removing the plastic enclosure. The target board features a MSP430F2274 and most of its pins are easily accessible. The following pins are:

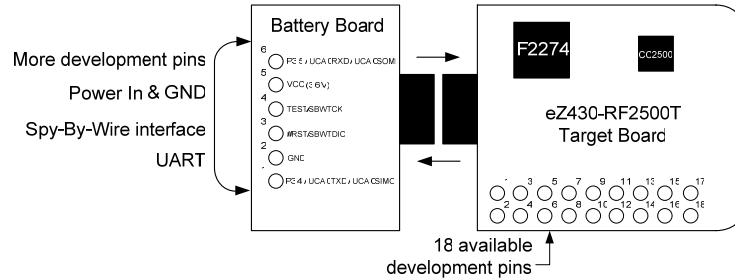

Figure 3. eZ430-RF2500 Development Tool

eZ430-RF2500T target board pin-outs:

Pin	Function	Description
1	GND	Ground Reference
2	VCC	Supply Voltage
3	P2.0 / ACLK / A0 / OA00	General-purpose digital I/O pin / ACLK output / ADC10, analog input A0
4	P2.1 / TAINCLK / SMCLK / A1 / OA00	General-purpose digital I/O pin / ADC10, analog input A1 Timer_A, clock signal at INCLK, SMCLK signal output
5	P2.2 / TA 0 / A2 / OA01	General-purpose digital I/O pin / ADC10, analog input A2 Timer_A, capture: CCI0B input/BSL receive, compare: OUT0 output
6	P2.3 / TA 1 / A3 / VREF - / VeREF - / OA11 / OA10	General-purpose digital I/O pin / Timer_A, capture: CCI1B input, compare: OUT1 output / ADC10, analog input A3 / negative reference voltage output/input
7	P2.4 / TA 2 / A4 / VREF + / VeREF + / OA10	General-purpose digital I/O pin / Timer_A, compare: OUT2 output / ADC10, analog input A4 / positive reference voltage output/input
8	P4.3 / TB0 / A12 / OA00	General-purpose digital I/O pin / ADC10 analog input A12 / Timer_B, capture: CCI0B input, compare: OUT0 output
9	P4.4 / TB1 / A13 / OA10	General-purpose digital I/O pin / ADC10 analog input A13 / Timer_B, capture: CCI1B input, compare: OUT1 output
10	P4.5 / TB2 / A14 / OA013	General-purpose digital I/O pin / ADC10 analog input A14 / Timer_B, compare: OUT2 output
11	P4.6 / TBOUTH / A15 / OA113	General-purpose digital I/O pin / ADC10 analog input A15 / Timer_B, switch all TB0 to TB3 outputs to high impedance
12	GND	Ground Reference
13	P2.6 / XIN (GDO0)	General-purpose digital I/O pin / Input terminal of crystal oscillator
14	P2.7 / XOUT (GDO2)	General-purpose digital I/O pin / Output terminal of crystal oscillator
15	P3.2 / UCB 0SOMI / UCB 0SCL	General-purpose digital I/O pin USCI_B0 slave out/master in in SPI mode, SCL I2C clock in I2C mode
16	P3.3 / UCB 0CLK / UCA 0STE	General-purpose digital I/O pin USCI_B0 clock input/output / USCI_A0 slave transmit enable
17	P3.0 / UCB 0STE / UCA 0CLK / A5	General-purpose digital I/O pin / USCI_B0 slave transmit enable / USCI_A0 clock input/output / ADC10, analog input A5
18	P3.1 / UCB 0SIMO / UCB 0SDA	General-purpose digital I/O pin / USCI_B0 slave in/master out in SPI mode, SDA I2C data in I2C mode

\*pins 13 -18 may be used to test the connection between the F2274 & CC2500

Battery Board pin-outs:

Pin	Function	Description
1	P3.4 / UCA 0TXD / UCA 0SIMO	General-purpose digital I/O pin / USCI_A0 transmit data output in UART mode (UART communication from 2274 to PC), slave in/master out in SPI mode
2	GND	Ground Reference
3	TEST/SBWTCK	Selects test mode for JTAG pins on Port1. The device protection fuse is connected to TEST. Spy-Bi-Wire test clock input during programming and test
4	#RST/SBWDIO	Reset or nonmaskable interrupt input. Spy-Bi-Wire test data input/output during programming and test
5	VCC (3.6V)	Supply Voltage
6	P3.5 / UCA 0RXD / UCA 0SOMI	General-purpose digital I/O pin / USCI_A0 receive data input in UART mode (UART communication from 2274 to PC), slave out/master in in SPI mode

## 4. Specifications

### MSP430F2274

- 16-MIPS performance
- 200ksps 10-bit SAR ADC
- 2 built-in Op-Amps
- Watchdog timer, 16-bit Timer\_A3 and B3
- USCI module supporting UART/LIN, (2) SPI, I2C, or IrDA
- Five low power modes drawing as little as 700nA in standby

PARAMETER	MIN	TYP	MAX	UNIT
<b>OPERATING CONDITIONS:</b>				
Operating supply voltage	1.8		3.6	V
Operating free-air temperature range	-40		85	°C
<b>CURRENT CONSUMPTION</b>				
Active Mode at 1Mhz, 2.2V		270	390	µA
Standby Mode		0.7	1.4	µA
Off Mode with RAM Retention		0.1	0.5	µA
<b>OPERATING FREQUENCY</b>				
V <sub>cc</sub> ≥ 3.3V			16	MHz

### CC2500

- 2.4GHz RF Transceiver
- Programmable data rate up to 500kbps
- Low current consumption

PARAMETER	MIN	TYP	MAX	UNIT	CONDITION
<b>OPERATING CONDITIONS:</b>					
Operating supply voltage	1.8		3.6	V	
<b>CURRENT CONSUMPTION</b>					
RX input signal at the sensitivity limit, 250 kbps		16.6		mA	Optimized current
		18.8		mA	Optimized sensitivity
RX input signal 30 dB above the sensitivity limit, 250 kbps		13.3		mA	Optimized current
		15.7		mA	Optimized sensitivity
Current consumption TX (0 dBm)		21.2		mA	
Current consumption TX (-12 dBm)		11.1		mA	
<b>RF CHARACTERISTICS</b>					
Frequency range	2400		2483.5	MHz	
Data rate (programmable)	1.2		500	kbps	
Output power (programmable)	-30		0	dBm	
Sensitivity, 10 kbps		-99		dBm	Optimized current, 2-FSK, 230 kHz RX filter bandwidth, 1% PER
		-101		dBm	Optimized sensitivity
Sensitivity, 250 kbps		-87		dBm	Optimized current, 500 kHz RX filter bandwidth, 1% PER
		-89		dBm	Optimized sensitivity

## 5. Supported Devices

The eZ430-RF USB debugging interface may be used as a standard Flash Emulation Tool through its Spy-Bi-Wire interface. The eZ430-RF USB debugging interface supports the following MSP430 families:

- MSP430F20xx
- MSP430F22xx

The connector on the USB debugging interface is backward compatible with the eZ430-F2013 and T2012 target boards.

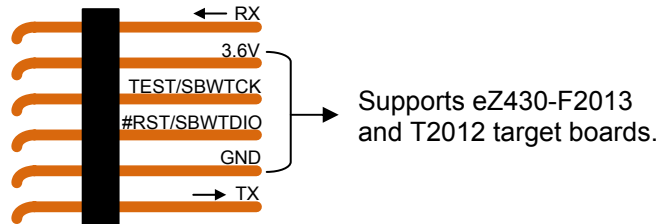

Figure 4. eZ430-RF2500 USB Debugging Interface 6-pin male header

## 6. MSP430 Application UART

The eZ430-RF USB debugging interface features a back channel MSP430 Application UART that may be used independently of a debug session. This allows the user to transfer serial data to a terminal window at a fixed rate of **9600bps** with **No flow control**. See Figure 5 for typical settings.

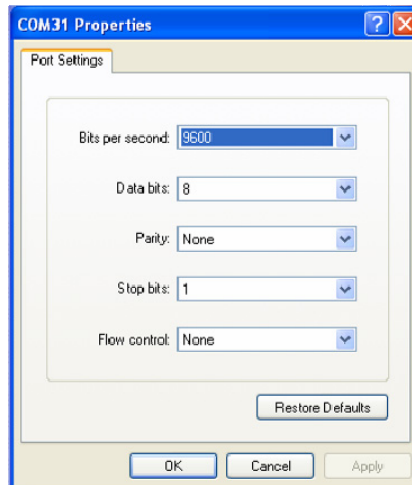

Figure 5. 9600bps with No flow control.

Check the Device Manager for COM-port assignment of the MSP430 Application UART. See Hardware Install Guide Section 14 for more details.

## 7. Software Installation

The CD-ROM includes 2 different development software tools for the MSP430 which includes IAR Embedded Workbench Kickstart and Code Composer Essentials (CCE). The term “Kickstart” refers to the limited version of Embedded Workbench which allows up to 4kb of C-code compilation. The included CCE is also limited but allows up to 8kb of code compilation. The full version of CCE Pro offers unlimited code compilation which can be purchased from [www.ti.com/msp430](http://www.ti.com/msp430).

1. Insert the eZ430-RF2500 CD-ROM into your computer. The eZ430-RF2500 start page should automatically display. If not, you can also use a browser to open “index.htm” that is located in the root directory of the eZ430-RF2500 CD-ROM.

The eZ430-RF2500 is compatible with Windows 2000, and XP.

2. Select **Software** → **IAR Workbench Kickstart / Code Composer Essentials** and follow the instructions.
3. Respond to the prompts to install the software. The installation procedure will install the IDE and TI files. Finish the installation.

## 8. Hardware Installation

1. Insert the eZ430-RF into USB port. The debugging interface will automatically install itself.
2. (Optional) When prompted for the software for the MSP430 Application UART, allow Windows to “**Install the software automatically.**” This is only possible if IAR Kickstart R4.64 or higher has already been installed.

For more detailed information see **Section 14: Detailed Hardware Install Guide.**

## 9. SimpliCI™

SimpliCI™ is a simple low-power RF network protocol aimed at small RF networks and may be used as a starting point to for your wireless network. Such networks typically contain battery operated devices which require long battery life, low data rate and low duty cycle and have a limited number of nodes talking directly to each other or through an access point or range extenders. Access point and range extenders are not required but provide extra functionality such as store and forward messages. With SimpliCI, the MCU resource requirements are minimal which results in the low system cost.

SimpliCI was designed for easy implementation and deployment out-of-the-box on several TI RF platforms such as the MSP430 family of low-power MCUs and the CC1xxx/CC25xx transceivers.

The eZ430-RF2500 demo application uses SimpliCI to demonstrate a temperature sensor network application that provides a starting point to develop your wireless applications.

**NOTE:** For the latest SimpliCI version and more info, please go to [www.ti.com/simpliCI](http://www.ti.com/simpliCI)

## 10. Demo – MSP430 Sensor Monitor

eZ430-RF2500 is preloaded with a wireless temperature sensor network firmware and may be reprogrammed at any time. The included PC visualizer provides a demonstration of the eZ430-RF2500 using SimpliCI across a star network. In the PC visualizer, the center node is the Access Point and the attached bubbles are the End Devices. The PC application displays the temperature of both the End Devices and Access Point. Additionally, the PC application is capable of simulating distance from its access point when the End Devices are moved. You can also expand the number of End Devices by adding more target boards in the star network as seen in the figure below.

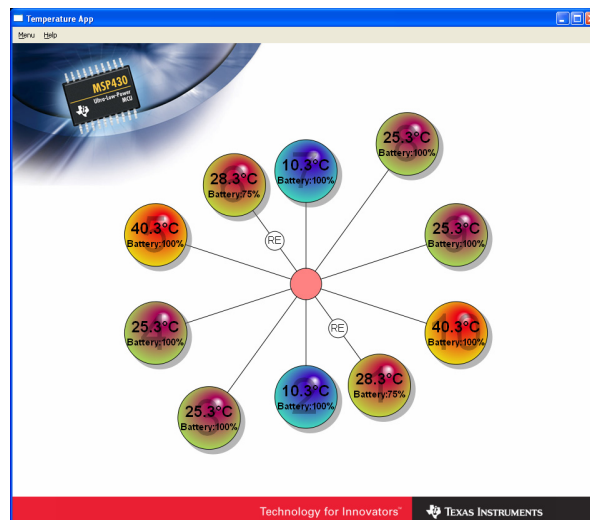

## 10.1. Demo Hardware Setup

1. Connect the eZ430-RF2500 to a USB port on your PC.
2. Connect the 2<sup>nd</sup> eZ430-RF2500T target board to the battery board. Insert the jumper on the board to power-up the device.

## 10.2. Demo Firmware Download

The following details the steps to update the demo application firmware on the eZ430-RF2500 target boards and are not required out-of-the box.

1. Open IAR Workbench Kickstart.
2. Select “**Open Existing Workspace**” and browse for the demo application workspace (\*.eww) file. The project is available on the CD or at [www.ti.com/ez430-rf](http://www.ti.com/ez430-rf).
3. To download demo firmware, follow steps 3a for Access Point firmware and 3b for End Device firmware.
  - 3a. Right click on **Access Point** project in the workspace and click “**Set as Active**” as shown in Figure 3.
  - 3b. Right click on **End Device** project in the workspace and click “**Set as Active**”.

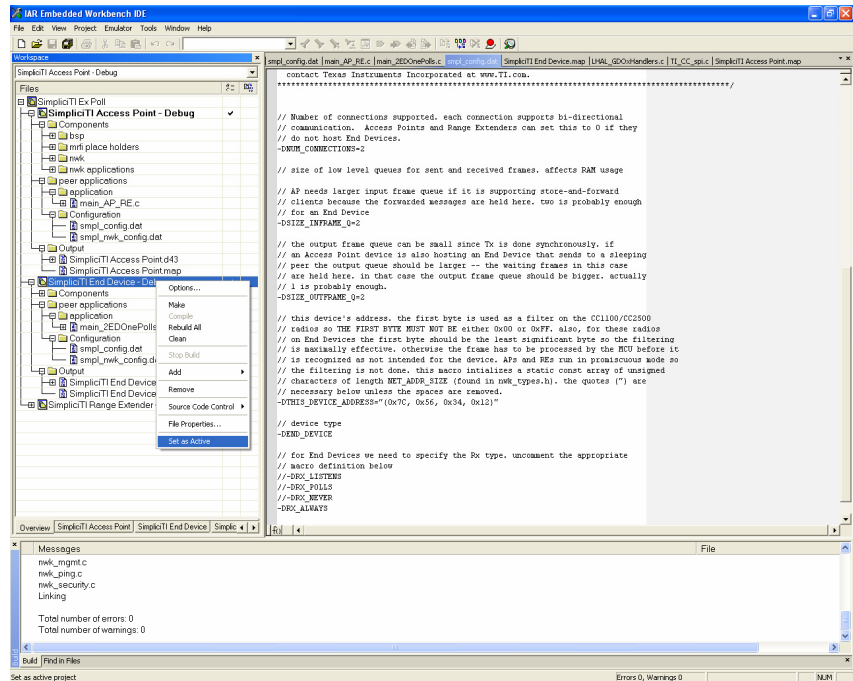

Figure 6. IAR Embedded Workbench Kickstart Workspace

4. Select “**Project**” → “**Debug**” in IAR to download the code for the target boards.
5. Select “**Debug**” → “**Go**” to start running code while in debug mode.
6. Click “**Debug**” → “**Stop Debugging**” exits the debug mode while leaving the target board executing code.

### 10.3. Demo Software GUI Setup

1. Ensure the Access Point is connected to the PC.
2. Apply power to the End Device.
3. Launch eZ430-RF Temperature Demo PC application (SensorMonitorGUI.exe). It is available on the CD at <CD ROOT>/demo/Demo Visualizer/ or at [www.ti.com/ez430-rf](http://www.ti.com/ez430-rf).
4. The PC application should automatically display End Devices when in range.

### 10.4. Demo Options

1. Go to **Menu** → **Settings**.
2. Under the settings menu, the demo application is capable of displaying values in Celsius or Fahrenheit.
3. Checking the box “**Disable Animations**” disables the dynamic distance change, thus decreasing CPU processing on PC.
4. See the demo application help file by clicking **Help** for more detailed options.

## 11. Suggested Reading

The primary sources of MSP430 information are the device-specific data sheets and User's Guides. The most up to date versions of the User's Guide documents available at the time of production have been provided on the CD-ROM included with this tool. The most current information is found at [www.ti.com/msp430](http://www.ti.com/msp430). Information specific to the eZ430-RF2500 development tool can be found at [www.ti.com/ez430-rf](http://www.ti.com/ez430-rf).

MSP430 device User's Guides and the FET User's Guide may be accessed from the main page on the CD-ROM under the User's Guides section. The FET User's Guide includes detailed information on setting up a project for the MSP430 using IAR.

Documents describing the IAR tools (Workbench/C-SPY, the assembler, the C compiler, the linker, and the library) are located in common\doc and 430\doc. The documents are in PDF-format. Supplements to the documents (i.e., the latest information) are available in HTML-format within the same directories. 430\doc\readme\_start.htm provides a convenient starting point for navigating the IAR documentation.

## 12. Frequently Asked Questions (FAQ)

1) **Does the eZ430-RF2500 support fuse blow?**

The eZ430-RF USB debugging interface lacks the JTAG security fuse blow capability. To ensure firmware security on devices going to production, the USB Flash Emulation Tool or the Gang Programmer, which include the fuse blow feature are recommended.

2) **What is the voltage supplied to the eZ430-RF2500T target board from the debugging interface?**

The eZ430-RF USB debugging interface supplies a regulated 3.6V to the eZ430-RF2500T target board.

3) **Can other programming tools interface to the eZ430-RF2500T target board?**

The eZ430-RF2500T target board will work with any programming tool supporting the 2-wire Spy Bi-Wire interface. Both the MSP430 USB FET (MSP-FET430UIF) and the Gang Programmer (MSP-GANG430) support these devices. See MSP-FET430 Flash Emulation Tool User's Guide (SLAU138) for details on using MSP430 USB FET and the Gang Programmer for a 2-wire Spy-Bi-Wire interface.

4) **What versions of IAR Embedded Workbench and CCE are supported?**

The eZ430-RF2500 is supported by IAR Embedded Workbench KickStart Release 4.64 (IAR 3.42F) and Code Composer Essentials v2.03 (SP3).

5) **What are the part numbers for the connectors between the eZ430-RF USB debugger and the eZ430-RF2500T target board?**

- Header: Mill-Max 850-10-006-20-001000
- Socket: Mill-Max 851-93-006-20-001000

Mill-Max: <http://www.mill-max.com>

6) **Where can I obtain more information about the 2.4GHz chip antenna?**

Part Number: 7488910245

Würth Elektronik Group: [www.we-online.com](http://www.we-online.com)

### 13. eZ430-RF2500 Schematics

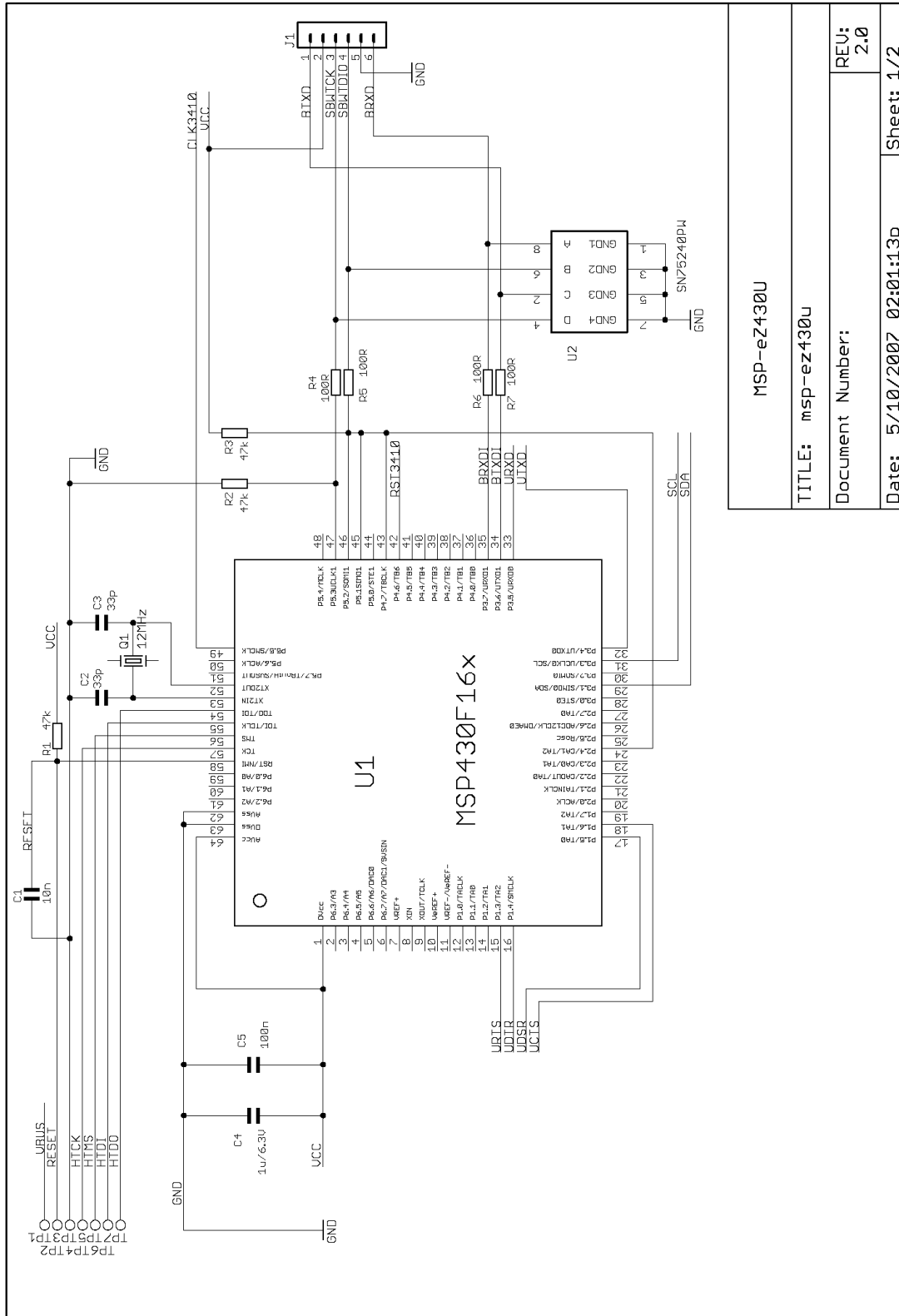

MSP-eZ430U	
TITLE: msp-ez430U	
Document Number:	
Date: 5/10/2007 02:01:13p	Sheet: 1/2

Figure 7. eZ430-RF, USB Debugging Interface, Schematic

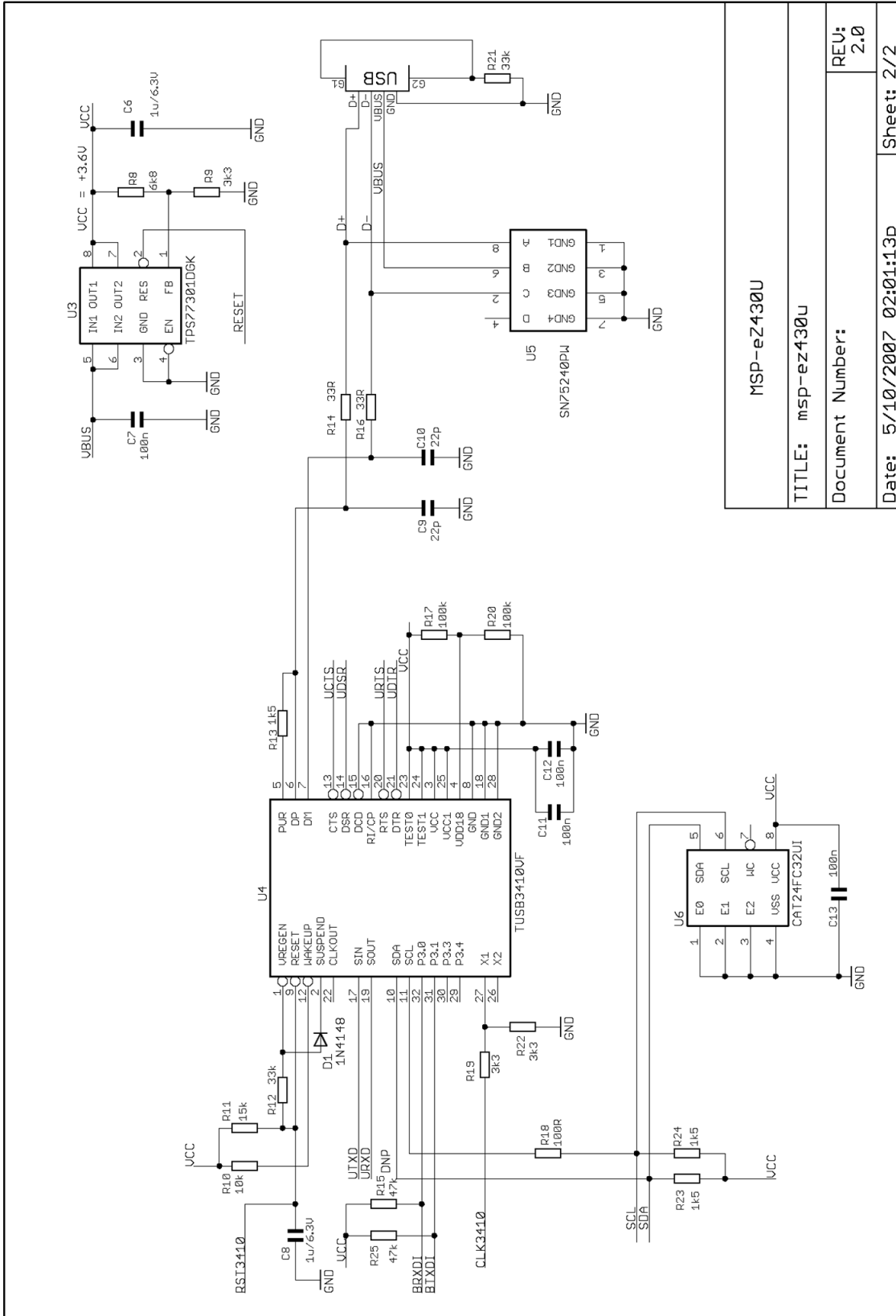

MSP-eZ430U	
TITLE:	mSP-eZ430U
Document Number:	REU: 2.0
Date:	5/10/2007 02:01:13p
Sheet: 2/2	

Figure 8. eZ430-RF, USB Debugging Interface, Schematic



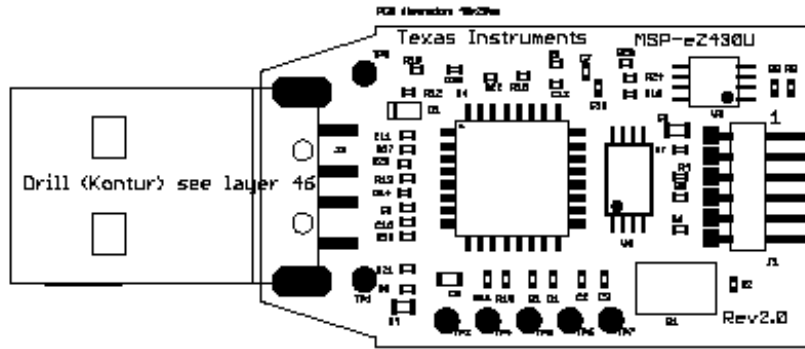

Figure 10. eZ430-RF, USB Debugger, PCB Components Layout

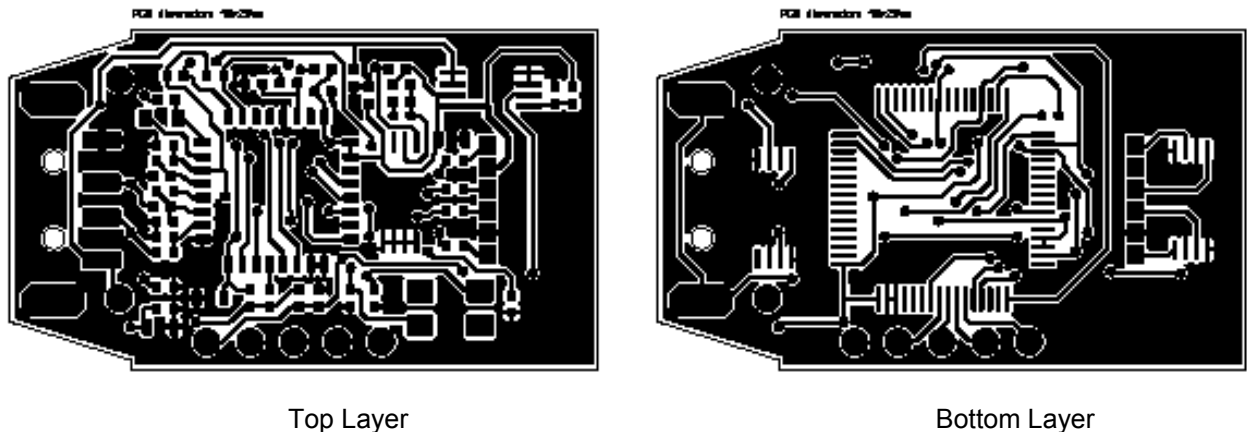

Figure 11. eZ430-RF, USB Debugger, PCB Layout

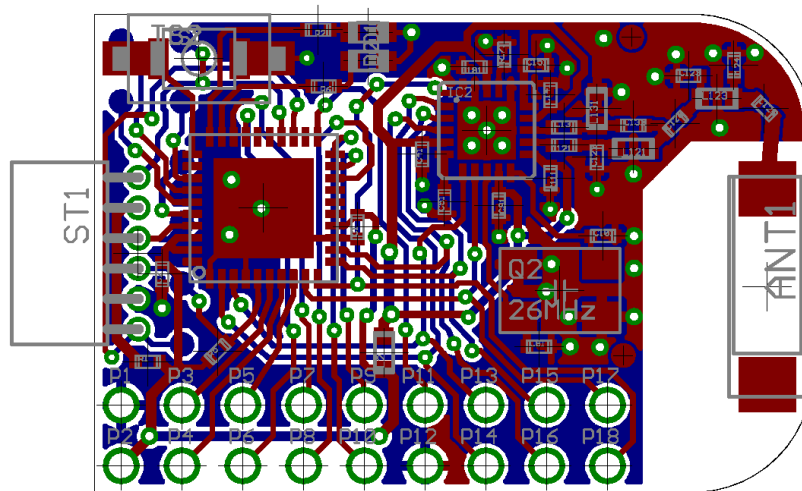

Figure 12. eZ430-RF2500T, Target Board, PCB Layout

## 14. Detailed Hardware Install Guide

1. Insert the eZ430-RF2500 CD into a CD drive.
2. Install IAR Embedded Workbench KickStart (R4.64 or newer) included on the CD or from [www.ti.com/msp430](http://www.ti.com/msp430).
3. Insert the eZ430-RF2500 into a USB port of your PC.
4. Windows should recognize the new hardware as **Texas Instruments MSP-FET430UIF** (Figure 13). Windows should automatically install the drivers for the MSP-FET430UIF as a HID tool.



Figure 13. Windows XP Hardware Recognition

5. Windows will recognize another new hardware driver to be installed called **MSP430 Application UART** (Figure 14).

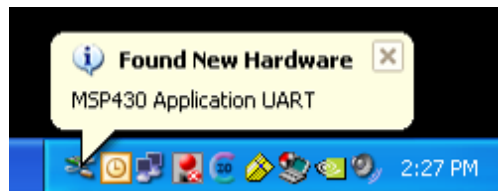

Figure 14. Windows XP Hardware Recognition for MSP430 Application UART

**NOTE:** This Installation Step is **Optional**. The USB debugging interface will work without the MSP430 Application UART.

6. The “Found New Hardware Wizard” should pop up with a dialog window. Select **“No, not this time”** and click Next (Figure 15).



Figure 15. Windows XP Found New Hardware Wizard

7. Select **“Install the software automatically (Recommended)”** (Figure 16). Assuming IAR Kickstart R4.64 or higher has already been installed.

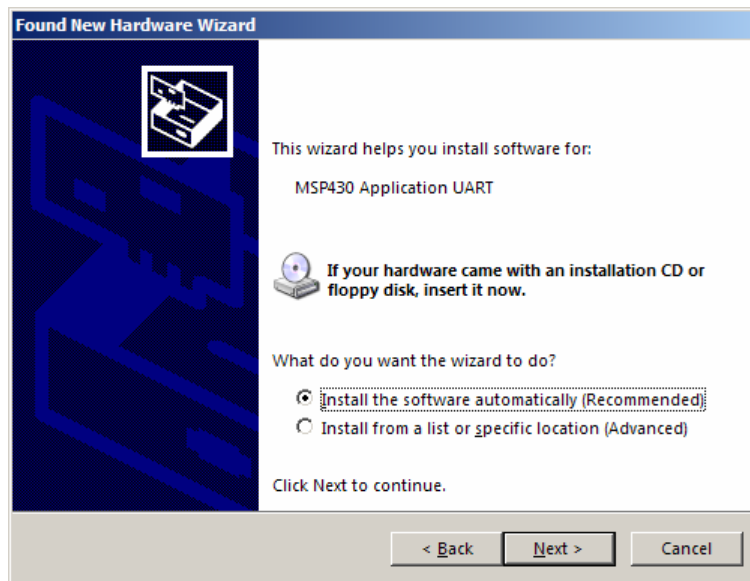
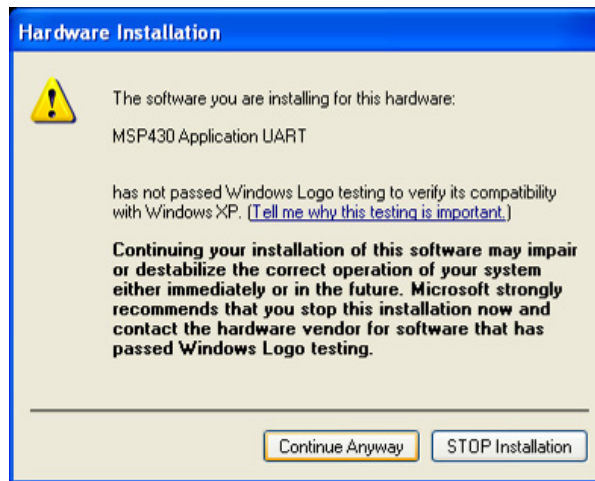

Figure 16. Windows XP Hardware Wizard

8. The Wizard should find the appropriate driver for a Windows XP system; it will prompt you with a warning that Microsoft did not certify the driver. The drivers have been tested exhaustively and you may ignore this warning and click “**Continue Anyway**” (Figure 17).



*Figure 17. Windows XP Warning*

9. The Wizard will continue to install the driver and notify you that it has finished the installation of the software.

10. The eZ430-RF2500 is now installed and ready to use. Observe the Device Manager for the assigned COM-port for the MSP430 Application UART as shown in Figure 18.

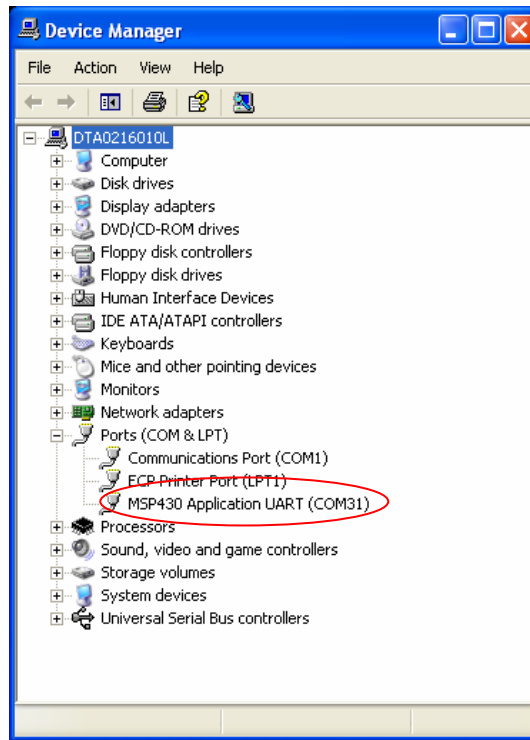

Figure 18. Device Manager