

Distributed by:

**JAMECO**<sup>®</sup>  
ELECTRONICS

**www.Jameco.com ♦ 1-800-831-4242**

The content and copyrights of the attached  
material are the property of its owner.

Jameco Part Number 1721897

## Features

- Configuration device family for configuring Stratix® series, Cyclone® series, APEX™ II, APEX 20K (including APEX 20K, APEX 20KC, and APEX 20KE), Mercury™, ACEX® 1K, and FLEX® (FLEX 10KE, and FLEX 10KA) devices
- Easy-to-use 4-pin interface to Altera® FPGAs
- Low current during configuration and near-zero standby current
- 5.0-V and 3.3-V operation
- Software design support with the Altera Quartus® II and MAX+PLUS® II development systems for Windows-based PCs as well as Sun SPARCstation, and HP 9000 Series 700/800
- Programming support with the Altera Programming Unit (APU) and programming hardware from Data I/O, BP Microsystems, and other third-party programmers
- Available in compact plastic packages
  - 8-pin plastic dual in-line package (PDIP)
  - 20-pin plastic J-lead chip carrier (PLCC) package
  - 32-pin plastic thin quad flat pack (TQFP) package
- EPC2 device has reprogrammable Flash configuration memory
  - 5.0-V and 3.3-V in-system programmability (ISP) through the built-in IEEE Std. 1149.1 Joint Test Action Group (JTAG) interface
  - Built-in JTAG boundary-scan test (BST) circuitry compliant with IEEE Std. 1149.1
  - ISP circuitry is compatible with IEEE Std. 1532
  - Supports programming through Serial Vector Format Files (**.svf**), Jam Standard Test and Programming Language (STAPL) Files (**.jam**), Jam STAPL Byte-Code Files (**.jbc**), and the Quartus II and MAX+PLUS II software via the USB Blaster, MasterBlaster™, ByteBlaster™ II, EthernetBlaster, or ByteBlasterMV™ download cable
  - nINIT\_CONF pin allows INIT\_CONF JTAG instruction to initiate FPGA configuration
  - Can be programmed with Programmer Object Files (**.pof**) for EPC1 and EPC1441 devices
  - Available in 20-pin PLCC and 32-pin TQFP packages



For detailed information on enhanced configuration devices, refer to *Enhanced Configuration Devices (EPC4, EPC8 & EPC16) Data Sheet*. For detailed information on serial configuration devices, refer to *Serial Configuration Devices (EPCS1, EPCS4, EPCS16, & EPCS64) Data Sheet*.

## Functional Description

With SRAM-based devices, configuration data must be reloaded each time the device powers up, the system initializes, or when new configuration data is needed. Altera configuration devices store configuration data for SRAM-based Stratix series, Cyclone series, APEX II, APEX 20K, Mercury, ACEX 1K, FLEX 10K, and FLEX 6000 devices. [Table 5–1](#) lists Altera configuration devices and their features.

**Table 5–1. Altera Configuration Devices**

Device	Memory Size (Bits)	ISP Support	Daisy Chain Support	Reprogrammable	Operating Voltage
EPC2	1,695,680	Yes	Yes	Yes	5.0 or 3.3 V
EPC1	1,046,496	No	Yes	No	5.0 or 3.3 V
EPC1441	440,800	No	No	No	5.0 or 3.3 V
EPC1213	212,942	No	Yes	No	5.0 V
EPC1064	65,536	No	No	No	5.0 V
EPC1064V	65,536	No	No	No	3.3 V

[Table 5–2](#) lists the supported configuration device(s) required to configure a Stratix, Stratix GX, Cyclone, APEX II, APEX 20K, Mercury, ACEX 1K or FLEX device.

**Table 5–2. Configuration Devices Required (Part 1 of 4)**

Family	Device	Data Size (Bits) (1)	EPC1064 /1064V	EPC1213	EPC1441	EPC1	EPC2
Stratix II (1.2 V) (2)	EP2S15	5,000,000					3
	EP2S30	10,100,000					7
	EP2S60	17,100,000					11
	EP2S90	27,500,000					17
	EP2S130	39,600,000					24
	EP2S180	52,400,000					31
Stratix (1.5 V)	EP1S10	3,534,640					3 (3)
	EP1S20	5,904,832					4
	EP1S25	7,894,144					5
	EP1S30	10,379,368					7
	EP1S40	12,389,632					8
	EP1S60	17,543,968					11
	EP1S80	23,834,032					15

**Table 5–2. Configuration Devices Required (Part 2 of 4)**

Family	Device	Data Size (Bits) (1)	EPC1064 /1064V	EPC1213	EPC1441	EPC1	EPC2
Stratix GX (1.5 V)	EP1SGX10	3,534,640					3
	EP1SGX25	7,894,144					5
	EP1SGX40	12,389,632					8
Cyclone II (1.2 V) (2)	EP2C5	1,223,980					1
	EP2C8	1,983,792					2
	EP2C20	3,930,986					3
	EP2C35	7,071,234					5
	EP2C50	9,122,148					6
	EP2C70	10,249,694					7
Cyclone (1.5 V)	EP1C3	627,376				1	1
	EP1C4	925,000				1	1
	EP1C6	1,167,216				1 (4)	1
	EP1C12	2,326,528					1 (4)
	EP1C20	3,559,608					2 (4)
APEX II (1.5 V)	EP2A15	1,168,688					3
	EP2A25	1,646,544					4
	EP2A40	2,543,016					6
	EP2A70	4,483,064					11
Mercury (1.8 V)	EP1M120	1,303,120					1
	EP1M350	4,394,032					3
APEX 20KC (1.8 V)	EP20K200C	1,968,016					2
	EP20K400C	3,909,776					3
	EP20K600C	5,673,936					4
	EP20K1000C	8,960,016					6

**Table 5–2. Configuration Devices Required (Part 3 of 4)**

Family	Device	Data Size (Bits) (1)	EPC1064 /1064V	EPC1213	EPC1441	EPC1	EPC2
APEX 20KE (1.8 V)	EP20K30E	354,832			1	1	1
	EP20K60E	648,016				1	1
	EP20K100E	1,008,016				1	1
	EP20K160E	1,524,016					1
	EP20K200E	1,968,016					2
	EP20K300E	2,741,616					2
	EP20K400E	3,909,776					3
	EP20K600E	5,673,936					4
	EP20K1000E	8,960,016					6
	EP20K1500E	12,042,256					8
APEX 20K (2.5 V)	EP20K100	993,360				1	1
	EP20K200	1,950,800					2
	EP20K400	3,880,720					3
ACEX 1K (2.5 V)	EP1K10	159,160			1	1	1
	EP1K30	473,720				1	1
	EP1K50	784,184				1	1
	EP1K100	1,335,720					1
FLEX 10KE (2.5 V)	EPF10K30E	473,720				1	1
	EPF10K50E	784,184				1	1
	EPF10K50S	784,184				1	1
	EPF10K100B	1,200,000					1
	EPF10K100E	1,335,720					1
	EPF10K130E	1,838,360					2
	EPF10K200E	2,756,296					2
	EPF10K200S	2,756,296					2
FLEX 10KA (3.3V)	EPF10K10A	120,000			1	1	1
	EPF10K30A	406,000			1	1	1
	EPF10K50V	621,000				1	1
	EPF10K100A	1,200,000					1
	EPF10K130V	1,600,000					1
	EPF10K250A	3,300,000					2

**Table 5–2. Configuration Devices Required (Part 4 of 4)**

Family	Device	Data Size (Bits) (1)	EPC1064 /1064V	EPC1213	EPC1441	EPC1	EPC2
FLEX 10K (5.0V)	EPF10K10	118,000			1	1	1
	EPF10K20	231,000			1	1	1
	EPF10K30	376,000			1	1	1
	EPF10K40	498,000				1	1
	EPF10K50	621,000				1	1
	EPF10K70	892,000				1	1
	EPF10K100	1,200,000					1
FLEX 6000/A (3.3 V)	EPF6010A	260,000			1	1	
	EPF6016 (5.0V) / EPF6016A	260,000			1	1	
	EPF6024A	398,000			1	1	
FLEX 8000A (5.0V)	EPF8282A / EPF8282AV (3.3 V)	40,000	1	1	1	1	
	EPF8452A	64,000	1	1	1	1	
	EPF8636A	96,000		1	1	1	
	EPF8820A	128,000		1	1	1	
	EPF81188A	192,000		1	1	1	
	EPF81500A	250,000			1	1	

**Notes to Table 5–2:**

- (1) Raw Binary Files (.rbf) were used to determine these sizes.
- (2) Information is preliminary.
- (3) EP1S10 ES devices requires four EPC2 devices
- (4) This is with the Stratix II or Cyclone series compression feature enabled.

Figure 5–1 shows the configuration device block diagram.

**Figure 5–1. Configuration Device Block Diagram**

**FPGA (except FLEX 8000) Configuration Using an EPC2, EPC1, or EPC1441**

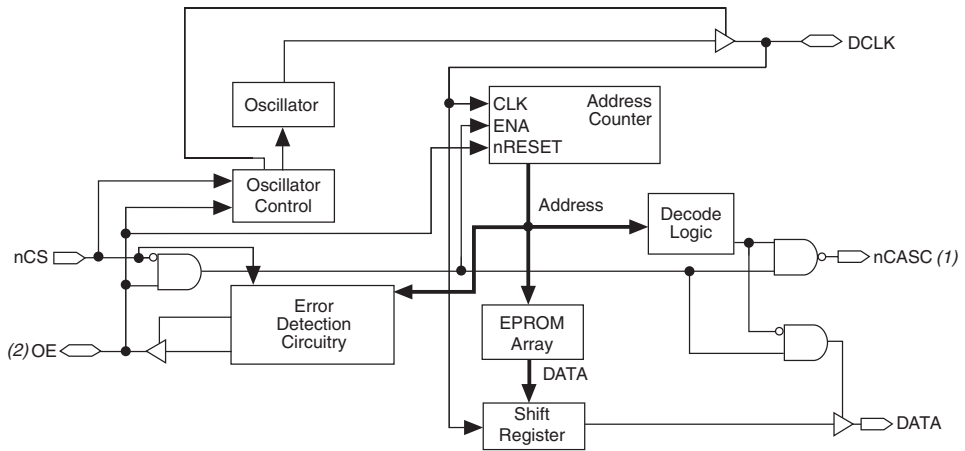

**FLEX 8000 Device Configuration Using an EPC1, EPC1441, EPC1213, EPC1064, or EPC1064V**

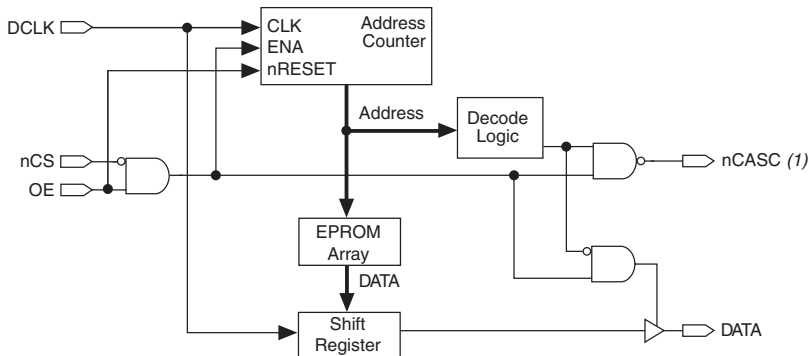

**Notes to Figure 5–1:**

- (1) The EPC1441 devices do not support data cascading. The EPC2, EPC1, and EPC1213 devices support data cascading.
- (2) The OE pin is a bidirectional open-drain pin.

## Device Configuration

The EPC2, EPC1, and EPC1441 devices store configuration data in its EPROM array and serially clock data out using an internal oscillator. The OE, nCS, and DCLK pins supply the control signals for the address counter

and the DATA output tri-state buffer. The configuration device sends a serial bitstream of configuration data to its DATA pin, which is routed to the DATA0 input of the FPGA.

The control signals for configuration devices (OE, nCS, and DCLK) interface directly with the FPGA control signals (nSTATUS, CONF\_DONE, and DCLK, respectively). All Altera FPGAs can be configured by a configuration device without requiring an external intelligent controller.

 An EPC2 device cannot configure FLEX 8000 or FLEX 6000 devices. See Table 5-2 for the configuration devices that support FLEX 8000 and FLEX 6000 devices.

Figure 5-2 shows the basic configuration interface connections between the configuration device and the Altera FPGA. For specific details on configuration interface connections, including pull-up resistor values, supply voltages and MSEL pin setting, refer to the appropriate FPGA family chapter in the Configuration Handbook.

**Figure 5-2. Altera FPGA Configured Using an EPC2, EPC1, or EPC1441 Configuration Device** Note (1)

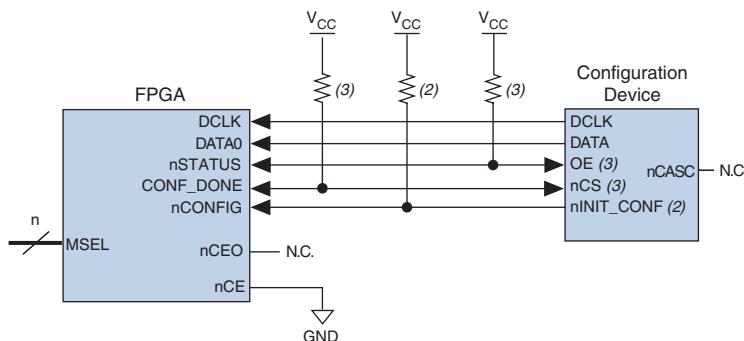

**Notes to Figure 5-2:**

- (1) For specific details on configuration interface connections refer to the FPGA family chapter in the Configuration Handbook.
- (2) The nINIT\_CONF pin (available on EPC2 devices) has an internal pull-up resistor that is always active. This means an external pull-up resistor is not required on the nINIT\_CONF/nCONFIG line. The nINIT\_CONF pin does not need to be connected if its functionality is not used. If nINIT\_CONF is not used or not available, nCONFIG must be pulled to V<sub>CC</sub> either directly or through a resistor.
- (3) EPC2 devices have internal programmable pull-up resistors on OE and nCS. If internal pull-up resistors are used, external pull-up resistors should not be used on these pins. The internal pull-up resistors are used by default in the Quartus II software. To turn off the internal pull-up resistors, check the **Disable nCS and OE pull-ups on configuration device** option when generating programming files.

The EPC2 device allows the user to initiate configuration of the FPGA via an additional pin, `nINIT_CONF`. The `nINIT_CONF` pin of the EPC2 device can be connected to the `nCONFIG` of the FPGA(s), which allows the `INIT_CONF` JTAG instruction to initiate FPGA configuration. The `INIT_CONF` JTAG instruction causes the EPC2 device to drive `nINIT_CONF` low, which in turn pulls `nCONFIG` low. Pulling `nCONFIG` low on the FPGA will reset the device. When the JTAG state machine exits this state, `nINIT_CONF` is released and pulled high by an internal 1-k $\Omega$  resistor, which in turn pulls `nCONFIG` high to initiate configuration. If its functionality is not used, the `nINIT_CONF` pin does not need to be connected and `nCONFIG` of the FPGA must be pulled to  $V_{CC}$  either directly or through a resistor.

The EPC2 device's `OE` and `nCS` pins have internal programmable pull-up resistors. If internal pull-up resistors are used, external pull-up resistors should not be used on these pins. The internal pull-up resistors are used by default in the Quartus II software. To turn off the internal pull-up resistors, check the **Disable nCS and OE pull-ups on configuration device** option when generating programming files.

The configuration device's `OE` and `nCS` pins control the tri-state buffer on its `DATA` output pin, and enable the address counter and oscillator. When `OE` is driven low, the configuration device resets the address counter and tri-states its `DATA` pin. The `nCS` pin controls the `DATA` output of the configuration device. If `nCS` is held high after the `OE` reset pulse, the counter is disabled and the `DATA` output pin is tri-stated. If `nCS` is driven low after the `OE` reset pulse, the counter and `DATA` output pin are enabled. When `OE` is driven low again, the address counter is reset and the `DATA` output pin is tri-stated, regardless of the state of `nCS`.

If the FPGA's configuration data exceeds the capacity of a single EPC2 or EPC1 configuration device, multiple EPC2 or EPC1 devices can be cascaded together. If multiple EPC2 or EPC1 devices are required, the `nCAS` and `nCS` pins provide handshaking between the configuration devices.



EPC1441 and EPC1064/V devices cannot be cascaded.

When configuring Stratix series, Cyclone series, APEX II, APEX 20K, Mercury, ACEX 1K, and FLEX 10K devices with cascaded EPC2 or EPC1 devices, the position of the EPC2 or EPC1 device in the chain determines its mode of operation. The first configuration device in the chain is the master, while subsequent configuration devices are slaves. The `nINIT_CONF` pin of the master EPC2 device can be connected to the `nCONFIG` of the FPGAs, which allows the `INIT_CONF` JTAG instruction to initiate FPGA configuration. The `nCS` pin of the master configuration device is connected to the `CONF_DONE` of the FPGA(s), while its `nCASC` pin is connected to `nCS` of the next slave configuration device in the chain. Additional EPC2 or EPC1 devices can be chained together by connecting `nCASC` to `nCS` of the next slave EPC2 or EPC1 device in the chain. The last device's `nCS` input comes from the previous device, while its `nCASC` pin is left floating. All other configuration pins (`DCLK`, `DATA`, and `OE`) are connected to every device in the chain.

Figure 5–3 shows the basic configuration interface connections between a configuration device chain and the Altera FPGA.

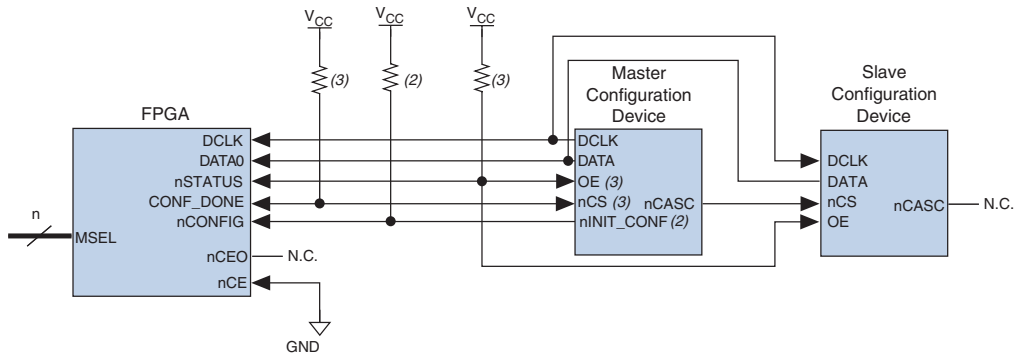

For specific details on configuration interface connections, including pull-up resistor values, supply voltages and `MSEL` pin setting, refer to the appropriate FPGA family chapter in the *Configuration Handbook*.

**Figure 5–3. Altera FPGA Configured Using Two EPC2 or EPC1 Configuration Devices** *Note (1)*

**Notes to Figure 5–3:**

- (1) For specific details on configuration interface connections refer to the appropriate FPGA family chapter in the Configuration Handbook.
- (2) The `nINIT_CONF` pin (available on EPC2 devices) has an internal pull-up resistor that is always active. This means an external pull-up resistor is not required on the `nINIT_CONF`/`nCONFIG` line. The `nINIT_CONF` pin does not need to be connected if its functionality is not used. If `nINIT_CONF` is not used or not available, `nCONFIG` must be pulled to VCC either directly or through a resistor.
- (3) EPC2 devices have internal programmable pull-up resistors on `OE` and `nCS`. If internal pull-up resistors are used, external pull-up resistors should not be used on these pins. The internal pull-up resistors are used by default in the Quartus II software. To turn off the internal pull-up resistors, check the **Disable nCS and OE pull-ups on configuration device** option when generating programming files.

When the first device in a configuration device chain is powered-up or reset, its `nCS` pin is driven low since it is connected to the `CONF_DONE` of the FPGA(s). Because both `OE` and `nCS` are low, the first device in the chain will recognize it is the master device and will control configuration. Since the slave devices' `nCS` pin is fed by the previous devices' `nCASC` pin, its `nCS` pin will be high upon power-up and reset. In the slave configuration devices, the `DATA` output is tri-stated and `DCLK` is an input. During configuration, the master device supplies the clock through `DCLK` to the FPGA(s) and to any slave configuration devices. The master EPC2 or EPC1 device also provides the first stream of data to the FPGA during multi-device configuration. After the master EPC2 or EPC1 device finishes sending configuration data, it tri-states its `DATA` pin to avoid contention with other configuration devices. The master EPC2 or EPC1 device will also drive its `nCASC` pin low, which pulls the `nCS` pin of the next device low. This action signals the slave EPC2 or EPC1 device to start sending configuration data to the FPGAs.

The master EPC2 or EPC1 device clocks all slave configuration devices until configuration is complete. Once all configuration data is transferred and the nCS pin on the master EPC2 or EPC1 device is driven high by the FPGA's CONF\_DONE pin, the master EPC2 or EPC1 device then goes into zero-power (idle) state. The master EPC2 device drives DATA high and DCLK low, while the EPC1 and EPC1441 device tri-state DATA and drive DCLK low.

If nCS on the master EPC2 or EPC1 device is driven high before all configuration data is transferred, the master EPC2 or EPC1 device drives its OE signal low, which in turn drives the FPGA's nSTATUS pin low, indicating a configuration error. Additionally, if the configuration device sends all of its data and detects that CONF\_DONE has not gone high, it recognizes that the FPGA has not configured successfully. EPC2 and EPC1 devices wait for 16 DCLK cycles after the last configuration bit was sent for CONF\_DONE to reach a high state. In this case, the configuration device pulls its OE pin low, which in turn drives the target device's nSTATUS pin low. Configuration automatically restarts if the **Auto-restart configuration on error** option is turned on in the Quartus II software from the **General** tab of the **Device & Pin Options** dialog box or the MAX+PLUS II software's **Global Project Device Options** dialog box (Assign menu).



For more information on FPGA configuration and configuration interface connections between configuration devices and Altera FPGA(s), refer to the appropriate FPGA family chapter in the *Configuration Handbook*.

## Power & Operation

This section describes Power-On Reset (POR) delay, error detection, and 3.3-V and 5.0-V operation of Altera configuration devices.

### Power-On Reset (POR)

During initial power-up, a POR delay occurs to permit voltage levels to stabilize. When configuring an FPGA with an EPC2, EPC1, or EPC1441 device, the POR delay occurs inside the configuration device, and the POR delay is a maximum of 200 ms. When configuring a FLEX 8000 device with an EPC1213, EPC1064, or EPC1064V device, the POR delay occurs inside the FLEX 8000 device, and the POR delay is typically, 100 ms, with a maximum of 200 ms.

During POR, the configuration device drives its OE pin low. This low signal delays configuration because the OE pin is connected to the target FPGA's nSTATUS pin. When the configuration device completes POR, it releases its open-drain OE pin, which is then pulled high by a pull-up resistor.



The FPGA(s) should be powered up before the configuration device exits POR to avoid the master configuration device from entering slave mode.

If the FPGA is not powered up before the configuration device exits POR, the CONF\_DONE/nCS line will be high because of the pull-up resistor. When the configuration device exits POR and releases OE, it sees nCS high, which signals the configuration device to enter slave mode. Therefore, configuration will not begin (the DATA output is tri-stated and DCLK is an input pin in slave mode).

### Error Detection Circuitry

The EPC2, EPC1, and EPC1441 configuration devices have built-in error detection circuitry for configuring Stratix series, Cyclone series, APEX II, APEX 20K, Mercury, ACEX 1K, FLEX 10K or FLEX 6000 devices.

Built-in error-detection circuitry uses the nCS pin of the configuration device, which monitors the CONF\_DONE pin on the FPGA. If nCS on the master EPC2 or EPC1 device is driven high before all configuration data is transferred, the master EPC2 or EPC1 device drives its OE signal low, which in turn drives the FPGA's nSTATUS pin low, indicating a configuration error. Additionally, if the configuration device sends all of its data and detects that CONF\_DONE has not gone high, it recognizes that the FPGA has not configured successfully. EPC2 and EPC1 devices wait for 16 DCLK cycles after the last configuration bit was sent for CONF\_DONE to reach a high state. In this case, the configuration device pulls its OE pin low, which in turn drives the target device's nSTATUS pin low. Configuration automatically restarts if the **Auto-restart configuration on error** option is turned on in the Quartus II software from the **General** tab of the **Device & Pin Options** dialog box or the MAX+PLUS II software's **Global Project Device Options** dialog box (Assign menu).

In addition, if the FPGA detects a cyclic redundancy code (CRC) error in the received data, it will flag the error by driving nSTATUS low. This low signal on nSTATUS will drive the OE pin of the configuration device low, which will reset the configuration device. CRC checking is performed when configuring all Altera FPGAs.

### 3.3-V or 5.0-V Operation

The EPC2, EPC1 and EPC 1441 configuration device may be powered at 3.3 V or 5.0 V. For each configuration device, an option must be set for 5.0-V or 3.3-V operation.

For EPC1 and EPC1441 configuration devices, 3.3-V or 5.0-V operation is controlled by a programming bit in the POF. The **Low-Voltage mode** option in the **Options** tab of the **Configuration Device Options** dialog box in the Quartus II software or the **Use Low-Voltage Configuration EPROM** option in the **Global Project Device Options** dialog box (Assign menu) in the MAX+PLUS II software sets this parameter. For example, EPC1 devices are programmed automatically to operate in 3.3-V mode when configuring FLEX 10KA devices, which have a  $V_{CC}$  voltage of 3.3 V. In this example, the EPC1 device's  $V_{CC}$  pin is connected to a 3.3-V power supply.

For EPC2 devices, this option is set externally by the  $V_{CCSEL}$  pin. In addition, the EPC2 device has an externally controlled option, set by the  $V_{PPSEL}$  pin, to adjust the programming voltage to 5.0 V or 3.3 V. The functions of the  $V_{CCSEL}$  and  $V_{PPSEL}$  pins are described below. These pins are only available in the EPC2 devices.

- $V_{CCSEL}$  pin - For EPC2 configuration devices, 5.0-V or 3.3-V operation is controlled by the  $V_{CCSEL}$  option pin. The device functions in 5.0-V mode when  $V_{CCSEL}$  is connected to GND; the device functions in 3.3-V mode when  $V_{CCSEL}$  is connected to  $V_{CC}$ .
- $V_{PPSEL}$  pin - The EPC2  $V_{PP}$  programming power pin is normally tied to  $V_{CC}$ . For EPC2 devices operating at 3.3 V, it is possible to improve in-system programming times by setting  $V_{PP}$  to 5.0 V. For all other configuration devices,  $V_{PP}$  must be tied to  $V_{CC}$ . The EPC2 device's  $V_{PPSEL}$  pin must be set in accordance with the EPC2  $V_{PP}$  pin. If the  $V_{PP}$  pin is supplied by a 5.0-V supply,  $V_{PPSEL}$  must be connected to GND; if the  $V_{PP}$  pin is supplied by a 3.3-V power supply,  $V_{PPSEL}$  must be connected to  $V_{CC}$ .

Table 5-3 describes the relationship between the  $V_{CC}$  and  $V_{PP}$  voltage levels and the required logic level for  $V_{CCSEL}$  and  $V_{PPSEL}$ . A logic level of high means the pin should be connected to  $V_{CC}$ , while a low logic level means the pin should be connected to GND.

$V_{CC}$ Voltage Level (V)	$V_{PP}$ Voltage Level (V)	$V_{CCSEL}$ Pin Logic Level	$V_{PPSEL}$ Pin Logic Level
3.3	3.3	High	High
3.3	5.0	High	Low
5.0	5.0	Low	Low

At 3.3-V operation, all EPC2 inputs are 5.0-V tolerant, except DATA, DCLK, and nCASC. The DATA and DCLK pins are used only to interface between the EPC2 device and the FPGA it is configuring. The voltage tolerances of all EPC2 pins at 5.0 V and 3.3 V are listed in [Table 5-4](#).

**Table 5-4. EPC2 Input & Bidirectional Pin Voltage Tolerance**

Pin	5.0-V Operation		3.3-V Operation	
	5.0-V Tolerant	3.3-V Tolerant	5.0-V Tolerant	3.3-V Tolerant
DATA	✓	✓		✓
DCLK	✓	✓		✓
nCASC	✓	✓		✓
OE	✓	✓	✓	✓
nCS	✓	✓	✓	✓
VCCSEL	✓	✓	✓	✓
VPPSEL	✓	✓	✓	✓
nINIT_CONF	✓	✓	✓	✓
TDI	✓	✓	✓	✓
TMS	✓	✓	✓	✓
TCK	✓	✓	✓	✓

If an EPC2, EPC1 or EPC1441 configuration device is powered at 3.3 V, the nSTATUS and CONF\_DONE pull-up resistors must be connected to 3.3 V. If these configuration devices are powered at 5.0 V, the nSTATUS and CONF\_DONE pull-up resistors can be connected to 3.3 V or 5.0 V.

## Programming & Configuration File Support

The Quartus II and MAX+PLUS II development systems provide programming support for Altera configuration devices. During compilation, the Quartus II and MAX+PLUS II software automatically generates a POF, which can be used to program the configuration device(s). In a multi-device project, the software can combine the programming files for multiple Stratix series, Cyclone series, APEX II, APEX 20K, Mercury, ACEX 1K, and FLEX 10K devices into one or more configuration devices. The software allows you to select the appropriate configuration device to most efficiently store the data for each FPGA.

All Altera configuration devices are programmable using Altera programming hardware in conjunction with the Quartus II or MAX+PLUS II software. In addition, many third part programmers offer programming hardware that supports Altera configuration devices.



An EPC2 device can be programmed with a POF generated for an EPC1 or EPC1441 device. An EPC1 device can be programmed using a POF generated for an EPC1441 device.

EPC2 configuration devices can be programmed in-system through its industry-standard 4-pin JTAG interface. ISP capability in the EPC2 devices provides ease in prototyping and FPGA functionality. When programming multiple EPC2 devices in a JTAG chain, the Quartus II and MAX+PLUS II software and other programming methods employ concurrent programming to simultaneously program multiple devices and reduce programming time. EPC2 devices can be programmed and erased up to 100 times.

After programming an EPC2 device in-system, FPGA configuration can be initiated by the EPC2 INIT\_CONF JTAG instruction. See [Table 5–6](#).



For more information on programming and configuration support, refer to the following documents:

- *Altera Programming Hardware Data Sheet*
- *USB Blaster USB Port Download Cable Data Sheet*
- *MasterBlaster Serial/USB Communications Cable Data Sheet*
- *ByteBlaster II Parallel Port Download Cable Data Sheet*
- *ByteBlasterMV Parallel Port Download Cable Data Sheet*
- *ByteBlaster Parallel Port Download Cable Data Sheet*
- *BitBlaster Parallel Port Download Cable Data Sheet*

You can also program configuration devices using the Quartus II or MAX+PLUS II software with the Altera Programming Unit (APU), and the appropriate configuration device programming adapter. Table 5-5 shows which programming adapter to use with each configuration device.

**Table 5-5. Programming Adapters**

Device	Package	Adapter
EPC2	20-pin J-Lead 32-pin TQFP	PLMJ1213 PLMT1213
EPC1	8-pin DIP 20-pin J-Lead	PLMJ1213 PLMJ1213
EPC1441	8-pin DIP 20-pin J-Lead 32-pin TQFP	PLMJ1213 PLMJ1213 PLMT1064

The following steps explain how to program Altera configuration devices using the Quartus II software and the APU:

1. Choose the **Quartus II Programmer** (Tools menu).
2. Load the appropriate POF by clicking **Add**. The **Device** column displays the device for the current programming file.
3. Insert a blank configuration device into the programming adapter's socket.
4. Turn on the **Program/Configure**. You can also turn on **Verify** to verify the contents of a programmed device against the programming data loaded from a programming file.
5. Click **Start**.
6. After successful programming, you can place the configuration device on the PCB to configure the FPGA device.

The following steps explain how to program Altera configuration devices using the MAX+PLUS II software and the APU:

1. Open the MAX+PLUS II Programmer.
2. Load the appropriate POF using the **Select Programming File** dialog box (File menu). By default, the **Programmer** loads the current project's POF. The **Device** field displays the device for the current programming file.

3. Insert a blank configuration device into the programming adapter's socket.
4. Click **Program**.
5. After successful programming, you can place the configuration device on the PCB to configure the FPGA device.

If you are cascading EPC1 or EPC2 devices, you must generate multiple POFs. The first device POF will have the same name as the project, while the second device POF will have the same name as the first, but with a "\_1" extension (e.g., **top\_1.pof**).

## IEEE Std. 1149.1 (JTAG) Boundary-Scan Testing

The EPC2 provides JTAG BST circuitry that complies with the IEEE Std. 1149.1-1990 specification. JTAG boundary-scan testing can be performed before or after configuration, but not during configuration. The EPC2 device supports the JTAG instructions shown in Table 6.

The ISP circuitry in EPC2 devices is compatible with tools that support the IEEE Std. 1532. The IEEE Std. 1532 is a standard developed to allow concurrent ISP between multiple PLD vendors.

JTAG Instruction	OPCODE	Description
SAMPLE/PRELOAD	00 0101 0101	Allows a snapshot of a signal at the device pins to be captured and examined during normal device operation, and permits an initial data pattern output at the device pins.
EXTEST	00 0000 0000	Allows the external circuitry and board-level interconnections to be tested by forcing a test pattern at the output pins and capturing results at the input pins.
BYPASS	11 1111 1111	Places the 1-bit bypass register between the TDI and TDO pins, which allows the BST data to pass synchronously through a selected device to adjacent devices during normal device operation.
IDCODE	00 0101 1001	Selects the device IDCODE register and places it between TDI and TDO, allowing the device IDCODE to be serially shifted out of TDO. The device IDCODE for the EPC2 configuration device is shown below: 0000 0001000000000010 00001101110 1
USERCODE	00 0111 1001	Selects the USERCODE register and places it between TDI and TDO, allowing the USERCODE to be serially shifted out of TDO. The 32-bit USERCODE is a programmable user-defined pattern.

**Table 5–6. EPC2 JTAG Instructions (Part 2 of 2)**

JTAG Instruction	OPCODE	Description
INIT_CONF	00 0110 0001	This function initiates the FPGA re-configuration process by pulsing the <code>nINIT_CONF</code> pin low, which is connected to the FPGA(s) <code>nCONFIG</code> pin(s). After this instruction is updated, the <code>nINIT_CONF</code> pin is pulsed low when the JTAG state machine enters the Run-Test/Idle state. The <code>nINIT_CONF</code> pin is then released and <code>nCONFIG</code> is pulled high by the resistor after the JTAG state machine goes out of Run-Test/Idle state. The FPGA configuration starts after <code>nCONFIG</code> goes high. As a result, the FPGA is configured with the new configuration data stored in the configuration device. This function can be added to your programming file (POF, JAM, JBC) in the Quartus II software by enabling the <b>Initiate configuration after programming</b> option in the <b>Programmer options</b> window (Options menu). This instruction is also used by the MAX+PLUS II software, Jam STAPL Files, and JBC Files.
ISP Instructions	-	These instructions are used when programming an EPC2 device via JTAG ports with a USB Blaster, MasterBlaster, ByteBlaster II, EthernetBlaster, or ByteBlaster MV download cable, or using a Jam STAPL File ( <b>.jam</b> ), Jam STAPL Byte-Code File ( <b>.jbc</b> ), or SVF file via an embedded processor.



For more information, refer to *Application Note 39 (IEEE 1149.1 (JTAG) Boundary-Scan Testing in Altera Devices)* or the EPC2 BSDL files on the Altera web site.

Figure 5–4 shows the timing requirements for the JTAG signals.

**Figure 5–4. EPC2 JTAG Waveforms**

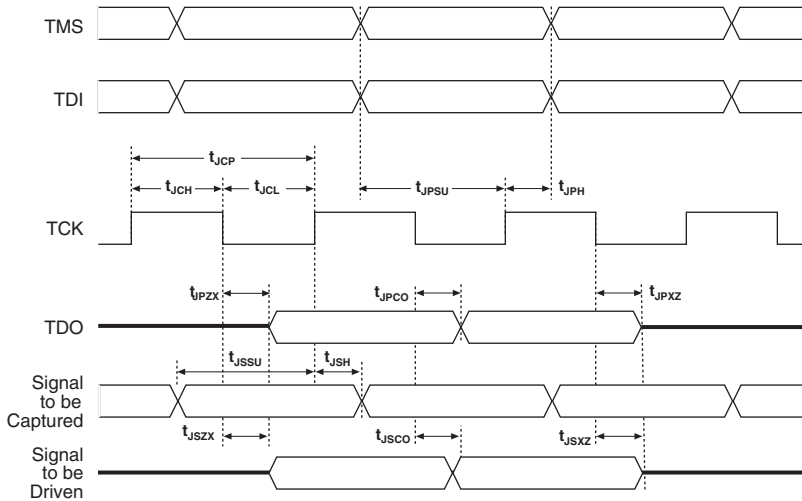

Table 5–7 shows the timing parameters and values for configuration devices.

<b>Table 5–7. JTAG Timing Parameters &amp; Values</b>				
<b>Symbol</b>	<b>Parameter</b>	<b>Min</b>	<b>Max</b>	<b>Unit</b>
$t_{JCP}$	TCK clock period	100		ns
$t_{JCH}$	TCK clock high time	50		ns
$t_{JCL}$	TCK clock low time	50		ns
$t_{JPSU}$	JTAG port setup time	20		ns
$t_{JPH}$	JTAG port hold time	45		ns
$t_{JPCO}$	JTAG port clock to output		25	ns
$t_{JPZX}$	JTAG port high impedance to valid output		25	ns
$t_{JPXZ}$	JTAG port valid output to high impedance		25	ns
$t_{JSSU}$	Capture register setup time	20		ns
$t_{JSH}$	Capture register hold time	45		ns
$t_{JSCO}$	Update register clock to output		25	ns
$t_{JSZX}$	Update register high-impedance to valid output		25	ns
$t_{JSXZ}$	Update register valid output to high impedance		25	ns

## Timing Information

Figure 5–5 shows the timing waveform when using a configuration device.

**Figure 5–5. Timing Waveform Using a Configuration Device**

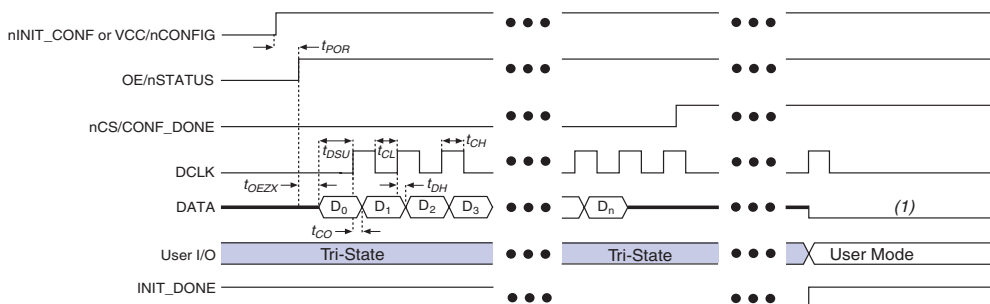

**Note to Figure 5–5:**

- (1) The EPC2 device will drive **DCLK** low and **DATA** high after configuration. The EPC1 and EPC1441 device will drive **DCLK** low and tri-state **DATA** after configuration.

Table 5–8 defines the timing parameters when using EPC2 devices at 3.3 V.

**Table 5–8. Timing Parameters when Using EPC2 devices at 3.3 V (Part 1 of 2)**

Symbol	Parameter	Min	Typ	Max	Units
$t_{POR}$	POR delay (1)			200	ms
$t_{OEZX}$	OE high to DATA output enabled			80	ns
$t_{CE}$	OE high to first rising edge on <b>DCLK</b>			300	ns
$t_{DSU}$	Data setup time before rising edge on <b>DCLK</b>	30			ns
$t_{DH}$	Data hold time after rising edge on <b>DCLK</b>	0			ns
$t_{CO}$	<b>DCLK</b> to <b>DATA</b> out			30	ns
$t_{CDOE}$	<b>DCLK</b> to <b>DATA</b> enable/disable			30	ns
$f_{CLK}$	<b>DCLK</b> frequency	5	7.7	12.5	MHz
$t_{MCH}$	<b>DCLK</b> high time for the first device in the configuration chain	40	65	100	ns
$t_{MCL}$	<b>DCLK</b> low time for the first device in the configuration chain	40	65	100	ns
$t_{SCH}$	<b>DCLK</b> high time for subsequent devices	40			ns
$t_{SCL}$	<b>DCLK</b> low time for subsequent devices	40			ns
$t_{CASC}$	<b>DCLK</b> rising edge to <b>nCASC</b>			25	ns

**Table 5–8. Timing Parameters when Using EPC2 devices at 3.3 V (Part 2 of 2)**

Symbol	Parameter	Min	Typ	Max	Units
$t_{CCA}$	nCS to nCASC cascade delay			15	ns
$t_{OEw}$	OE low pulse width (reset) to guarantee counter reset	100			ns
$t_{OEC}$	OE low (reset) to DCLK disable delay			30	ns
$t_{NRCAS}$	OE low (reset) to nCASC delay			30	ns

**Note to Table 5–8:**

- (1) During initial power-up, a POR delay occurs to permit voltage levels to stabilize. Subsequent reconfigurations do not incur this delay.

Table 5–9 defines the timing parameters when using EPC1 and EPC1441 devices at 3.3 V.

**Table 5–9. Timing Parameters when Using EPC1 & EPC1441 Devices at 3.3 V (Part 1 of 2)**

Symbol	Parameter	Min	Typ	Max	Units
$t_{POR}$	POR delay (1)			200	ms
$t_{OEZX}$	OE high to DATA output enabled			80	ns
$t_{CE}$	OE high to first rising edge on DCLK			300	ns
$t_{DSU}$	Data setup time before rising edge on DCLK	30			ns
$t_{DH}$	Data hold time after rising edge on DCLK	0			ns
$t_{CO}$	DCLK to DATA out			30	ns
$t_{CDOE}$	DCLK to DATA enable/disable			30	ns
$f_{CLK}$	DCLK frequency	2	4	10	MHz
$t_{MCH}$	DCLK high time for the first device in the configuration chain	50	125	250	ns
$t_{MCL}$	DCLK low time for the first device in the configuration chain	50	125	250	ns
$t_{SCH}$	DCLK high time for subsequent devices	50			ns
$t_{SCL}$	DCLK low time for subsequent devices	50			ns
$t_{CASC}$	DCLK rising edge to nCASC			25	ns
$t_{CCA}$	nCS to nCASC cascade delay			15	ns
$t_{OEw}$	OE low pulse width (reset) to guarantee counter reset	100			ns
$t_{OEC}$	OE low (reset) to DCLK disable delay			30	ns

## Timing Information

**Table 5–9. Timing Parameters when Using EPC1 & EPC1441 Devices at 3.3 V (Part 2 of 2)**

Symbol	Parameter	Min	Typ	Max	Units
$t_{NRCAS}$	OE low (reset) to $nCASC$ delay			30	ns

**Note to Table 5–9:**

- (1) During initial power-up, a POR delay occurs to permit voltage levels to stabilize. Subsequent reconfigurations do not incur this delay.

Table 5–10 defines the timing parameters when using EPC2, EPC1, and EPC1441 devices at 5.0 V.

**Table 5–10. Timing Parameters when Using EPC2, EPC1 & EPC1441 Devices at 5.0 V**

Symbol	Parameter	Min	Typ	Max	Units
$t_{POR}$	POR delay (1)			200	ms
$t_{OEZX}$	OE high to DATA output enabled			50	ns
$t_{CE}$	OE high to first rising edge on DCLK			200	ns
$t_{DSU}$	Data setup time before rising edge on DCLK	30			ns
$t_{DH}$	Data hold time after rising edge on DCLK	0			ns
$t_{CO}$	DCLK to DATA out			20	ns
$t_{CDOE}$	DCLK to DATA enable/disable			20	ns
$f_{CLK}$	DCLK frequency	6.7	10	16.7	MHz
$t_{MCH}$	DCLK high time for the first device in the configuration chain	30	50	75	ns
$t_{MCL}$	DCLK low time for the first device in the configuration chain	30	50	75	ns
$t_{SCH}$	DCLK high time for subsequent devices	30			ns
$t_{SCL}$	DCLK low time for subsequent devices	30			ns
$t_{CASC}$	DCLK rising edge to $nCASC$			20	ns
$t_{CCA}$	$nCS$ to $nCASC$ cascade delay			10	ns
$t_{OEW}$	OE low pulse width (reset) to guarantee counter reset	100			ns
$t_{OEC}$	OE low (reset) to DCLK disable delay			20	ns
$t_{NRCAS}$	OE low (reset) to $nCASC$ delay			25	ns

**Note to Table 5–10:**

- (1) During initial power-up, a POR delay occurs to permit voltage levels to stabilize. Subsequent reconfigurations do not incur this delay.

Table 5–11 defines the timing parameters when using EPC1, EPC1441, EPC1213, EPC1064, and EPC1064V devices when configuring FLEX 8000 device.

**Table 5–11. FLEX 8000 Device Configuration Parameters Using EPC1, EPC1441, EPC1213, EPC1064 & EPC1064V Devices**

Symbol	Parameter	EPC1064V		EPC1064 EPC1213		EPC1 EPC1441		Unit
		Min	Max	Min	Max	Min	Max	
$t_{OEZX}$	OE high to DATA output enabled		75		50		50	ns
$t_{CSZX}$	nCS low to DATA output enabled		75		50		50	ns
$t_{CSXZ}$	nCS high to DATA output disabled		75		50		50	ns
$t_{CSS}$	nCS low setup time to first DCLK rising edge	150		100		50		ns
$t_{CSH}$	nCS low hold time after DCLK rising edge	0		0		0		ns
$t_{DSU}$	Data setup time before rising edge on DCLK	75		50		50		ns
$t_{DH}$	Data hold time after rising edge on DCLK	0		0		0		ns
$t_{CO}$	DCLK to DATA out delay		100		75		75	ns
$t_{CK}$	Clock period	240		160		100		ns
$f_{CK}$	Clock frequency		4		6		8	MHz
$t_{CL}$	DCLK low time	120		80		50		ns
$t_{CH}$	DCLK high time	120		80		50		ns
$t_{XZ}$	OE low or nCS high to DATA output disabled		75		50		50	ns
$t_{OEW}$	OE pulse width to guarantee counter reset	150		100		100		ns
$t_{CASC}$	Last DCLK + 1 to nCASC low delay		90		60		50	ns
$t_{CKXZ}$	Last DCLK + 1 to DATA tri-state delay		75		50		50	ns
$t_{CEOUT}$	nCS high to nCASC high delay		150		100		100	ns

## Operating Conditions

Tables 5–12 through 5–19 provide information on absolute maximum ratings, recommended operating conditions, DC operating conditions, and capacitance for configuration devices.

**Table 5–12. Absolute Maximum Ratings** *Note (1)*

Symbol	Parameter	Conditions	Min	Max	Unit
$V_{CC}$	Supply voltage	With respect to ground (2)	-2.0	7.0	V
$V_I$	DC input voltage	With respect to ground (2)	-2.0	7.0	V
$I_{MAX}$	DC $V_{CC}$ or ground current			50	mA
$I_{OUT}$	DC output current, per pin		-25	25	mA
$P_D$	Power dissipation			250	mW
$T_{STG}$	Storage temperature	No bias	-65	150	°C
$T_{AMB}$	Ambient temperature	Under bias	-65	135	°C
$T_J$	Junction temperature	Under bias		135	°C

**Table 5–13. Recommended Operating Conditions**

Symbol	Parameter	Conditions	Min	Max	Unit
$V_{CC}$	Supply voltage for 5.0-V operation	(3), (4)	4.75 (4.50)	5.25 (5.50)	V
	Supply voltage for 3.3-V operation	(3), (4)	3.0 (3.0)	3.6 (3.6)	V
$V_I$	Input voltage	With respect to ground	-0.3	$V_{CC} + 0.3$ (5)	V
$V_O$	Output voltage		0	$V_{CC}$	V
$T_A$	Operating temperature	For commercial use	0	70	°C
		For industrial use	-40	85	°C
$t_R$	Input rise time			20	ns
$t_F$	Input fall time			20	ns

**Table 5–14. DC Operating Conditions**

Symbol	Parameter	Conditions	Min	Max	Unit
$V_{IH}$	High-level input voltage		2.0	$V_{CC} + 0.3$ (5)	V
$V_{IL}$	Low-level input voltage		-0.3	0.8	V
$V_{OH}$	5.0-V mode high-level TTL output voltage	$I_{OH} = -4$ mA DC (6)	2.4		V
	3.3-V mode high-level CMOS output voltage	$I_{OH} = -0.1$ mA DC (6)	$V_{CC} - 0.2$		V
$V_{OL}$	Low-level output voltage	$I_{OL} = 4$ mA DC (6)		0.4	V
$I_I$	Input leakage current	$V_I = V_{CC}$ or ground	-10	10	$\mu$ A
$I_{OZ}$	Tri-state output off-state current	$V_O = V_{CC}$ or ground	-10	10	$\mu$ A

**Table 5–15. EPC1213, EPC1064 & EPC1064V Device  $I_{CC}$  Supply Current Values**

Symbol	Parameter	Conditions	Min	Typ	Max	Unit
$I_{CC0}$	$V_{CC}$ supply current (standby)			100	200	$\mu$ A
$I_{CC1}$	$V_{CC}$ supply current (during configuration)			10	50	mA

**Table 5–16. EPC2 Device Values**

Symbol	Parameter	Conditions	Min	Typ	Max	Unit
$I_{CC0}$	$V_{CC}$ supply current (standby)	$V_{CC} = 5.0$ V or 3.3 V		50	100	$\mu$ A
$I_{CC1}$	$V_{CC}$ supply current (during configuration)	$V_{CC} = 5.0$ V or 3.3 V		18	50	$\mu$ A
$R_{CONF}$	Configuration pins	Internal pull up (OE, nCS, nINIT_CONF)		1		k $\Omega$

**Table 5–17. EPC1 Device  $I_{CC}$  Supply Current Values**

Symbol	Parameter	Conditions	Min	Typ	Max	Unit
$I_{CC0}$	$V_{CC}$ supply current (standby)			50	100	$\mu$ A
$I_{CC1}$	$V_{CC}$ supply current (during configuration)	$V_{CC} = 5.0$ V		30	50	mA
		$V_{CC} = 3.3$ V		10	16.5	mA

**Table 5–18. EPC1441 Device  $I_{CC}$  Supply Current Values**

Symbol	Parameter	Conditions	Min	Typ	Max	Unit
$I_{CC0}$	$V_{CC}$ supply current (standby)			30	60	$\mu\text{A}$
$I_{CC1}$	$V_{CC}$ supply current (during configuration)	$V_{CC} = 5.0\text{ V}$		15	30	$\text{mA}$
$I_{CC1}$	$V_{CC}$ supply current (during configuration)	$V_{CC} = 3.3\text{ V}$		5	10	$\text{mA}$

**Table 5–19. Capacitance** *Note (7)*

Symbol	Parameter	Conditions	Min	Max	Unit
$C_{IN}$	Input pin capacitance	$V_{IN} = 0\text{ V}$ , $f = 1.0\text{ MHz}$		10	$\text{pF}$
$C_{OUT}$	Output pin capacitance	$V_{OUT} = 0\text{ V}$ , $f = 1.0\text{ MHz}$		10	$\text{pF}$

**Notes to Tables 5–12 through 5–19:**

- (1) See the Operating Requirements for Altera Devices Data Sheet.
- (2) The minimum DC input is  $-0.3\text{ V}$ . During transitions, the inputs may undershoot to  $-2.0\text{ V}$  or overshoot to  $7.0\text{ V}$  for input currents less than  $100\text{ mA}$  and periods shorter than  $20\text{ ns}$  under no-load conditions.
- (3) Numbers in parentheses are for industrial temperature range devices.
- (4) Maximum  $V_{CC}$  rise time is  $100\text{ ms}$ .
- (5) Certain EPC2 pins may be driven to  $5.75\text{ V}$  when operated with a  $3.3\text{-V } V_{CC}$ . See [Table 5–4](#).
- (6) The  $I_{OH}$  parameter refers to high-level TTL or CMOS output current; the  $I_{OL}$  parameter refers to low-level TTL or CMOS output current.
- (7) Capacitance is sample-tested only.

## Pin Information

Table 5–20 describes EPC2, EPC1, and EPC1441 pin functions during device configuration.



For pin information on enhanced configuration devices, refer to the *Enhanced Configuration Devices (EPC4, EPC8 & EPC16) Data Sheet*. For pin information on serial configuration devices, refer to the *Serial Configuration Devices (EPCS1, EPCS4, EPCS16 & EPCS64) Data Sheet*.

**Table 5–20. EPC2, EPC1 & EPC1441 Pin Functions During Configuration (Part 1 of 4)**

Pin Name	Pin Number			Pin Type	Description
	8-Pin PDIP (1)	20-Pin PLCC	32-Pin TQFP (2)		
DATA	1	2	31	Output	Serial data output. The DATA pin connects to the DATA0 of the FPGA. DATA is latched into the FPGA on the rising edge of DCLK. The DATA pin is tri-stated before configuration and when the nCS pin is high. After configuration, the EPC2 device will drive DATA high, while the EPC1 and EPC1441 device will tri-state DATA.
DCLK	2	4	2	Bidirectional	Clock output when configuring with a single configuration device or when the configuration device is the first (master) device in a chain. Clock input for the next (slave) configuration devices in a chain. The DCLK pin connects to the DCLK of the FPGA. Rising edges on DCLK increment the internal address counter and present the next bit of data on the DATA pin. The counter is incremented only if the OE input is held high, the nCS input is held low, and all configuration data has not been transferred to the target device. After configuration or when OE is low, the EPC2, EPC1 and EPC1441 device will drive DCLK low.

**Table 5–20. EPC2, EPC1 & EPC1441 Pin Functions During Configuration (Part 2 of 4)**

Pin Name	Pin Number			Pin Type	Description
	8-Pin PDIP (1)	20-Pin PLCC	32-Pin TQFP (2)		
OE	3	8	7	Open-Drain Bidirectional	<p>Output enable (active high) and reset (active low). The OE pin connects to the nSTATUS of the FPGA.</p> <p>A low logic level resets the address counter. A high logic level enables DATA and the address counter to count. If this pin is low (reset) during configuration, the internal oscillator becomes inactive and DCLK drives low. See “<a href="#">Error Detection Circuitry</a>” on page 5–12.</p> <p>The OE pin has an internal programmable 1-kΩ resistor in EPC2 devices. If internal pull-up resistors are use, external pull-up resistors should not be used on these pins. The internal pull-up resistors can be disabled through the <b>Disable nCS and OE pull-ups on configuration device</b> option.</p>
nCS	4	9	10	Input	<p>Chip select input (active low). The nCS pin connects to the CONF_DONE of the FPGA.</p> <p>A low input allows DCLK to increment the address counter and enables DATA to drive out. If the EPC2 or EPC1 is reset (OE pulled low) while nCS is low, the device initializes as the master device in a configuration chain. If the EPC2 or EPC1 device is reset (OE pulled low) while nCS is high, the device initializes as a slave device in the chain.</p> <p>The nCS pin has an internal programmable 1-kΩ resistor in EPC2 devices. If internal pull-up resistors are use, external pull-up resistors should not be used on these pins. The internal pull-up resistors can be disabled through the <b>Disable nCS and OE pull-ups on configuration device</b> option.</p>

**Table 5–20. EPC2, EPC1 & EPC1441 Pin Functions During Configuration (Part 3 of 4)**

Pin Name	Pin Number			Pin Type	Description
	8-Pin PDIP (1)	20-Pin PLCC	32-Pin TQFP (2)		
nCASC	6	12	15	Output	Cascade select output (active low). This output goes low when the address counter has reached its maximum value. When the address counter has reached its maximum value, the configuration device has sent all its configuration data to the FPGA. In a chain of EPC2 or EPC1 devices, the nCASC pin of one device is connected to the nCS pin of the next device, which permits DCLK to clock data from the next EPC2 or EPC1 device in the chain. For single EPC2 or EPC1 devices and the last device in the chain, nCASC is left floating. This pin is only available in EPC2 and EPC1 devices, which support data cascading.
nINIT_CONF	N/A	13	16	Open-Drain Output	Allows the INIT_CONF JTAG instruction to initiate configuration. The nINIT_CONF pin connects to the nCONFIG of the FPGA. If multiple EPC2 devices are used to configure a FPGA(s), the nINIT_CONF of the first EPC2 pin is tied to the FPGA's nCONFIG pin, while subsequent devices' nINIT_CONF pins are left floating. The INIT_CONF pin has an internal 1-k $\Omega$ pull-up resistor that is always active in EPC2 devices. This pin is only available in EPC2 devices.
TDI	N/A	11	13	Input	JTAG data input pin. Connect this pin to V <sub>CC</sub> if the JTAG circuitry is not used. This pin is only available in EPC2 devices.
TDO	N/A	1	28	Output	JTAG data output pin. Do not connect this pin if the JTAG circuitry is not used. This pin is only available in EPC2 devices.
TMS	N/A	19	25	Input	JTAG mode select pin. Connect this pin to V <sub>CC</sub> if the JTAG circuitry is not used. This pin is only available in EPC2 devices.
TCK	N/A	3	32	Input	JTAG clock pin. Connect this pin to ground if the JTAG circuitry is not used. This pin is only available in EPC2 devices.

**Table 5–20. EPC2, EPC1 & EPC1441 Pin Functions During Configuration (Part 4 of 4)**

Pin Name	Pin Number			Pin Type	Description
	8-Pin PDIP (1)	20-Pin PLCC	32-Pin TQFP (2)		
VCCSEL	N/A	5	3	Input	Mode select for V <sub>CC</sub> supply. VCCSEL must be connected to ground if the device uses a 5.0-V power supply (V <sub>CC</sub> = 5.0 V). VCCSEL must be connected to VCC if the device uses a 3.3-V power supply (V <sub>CC</sub> = 3.3 V). This pin is only available in EPC2 devices.
VPPSEL	N/A	14	17	Input	Mode select for VPP. VPPSEL must be connected to ground if VPP uses a 5.0-V power supply (V <sub>PP</sub> = 5.0 V). VPPSEL must be connected to V <sub>CC</sub> if VPP uses a 3.3-V power supply (V <sub>PP</sub> = 3.3 V). This pin is only available in EPC2 devices.
VPP	N/A	18	23	Power	Programming power pin. For the EPC2 device, this pin is normally tied to VCC. If the EPC2 V <sub>CC</sub> is 3.3 V, VPP can be tied to 5.0 V to improve in-system programming times. For EPC1 and EPC1441 devices, VPP must be tied to V <sub>CC</sub> . This pin is only available in EPC2 devices.
VCC	7, 8	20	27	Power	Power pin.
GND	5	10	12	Ground	Ground pin. A 0.2-μF decoupling capacitor must be placed between the V <sub>CC</sub> and GND pins.

**Notes to Table 5–20:**

- (1) This package is available for EPC1 and EPC1441 devices only.  
(2) This package is available for EPC2 and EPC1441 devices only.

# Package

Figures 5–6 and 5–7 show the configuration device package pin-outs.

**Figure 5–6. EPC1, EPC1441, EPC1213, EPC1064 & EPC1064V Package Pin-Out Diagrams** *Note (1)*

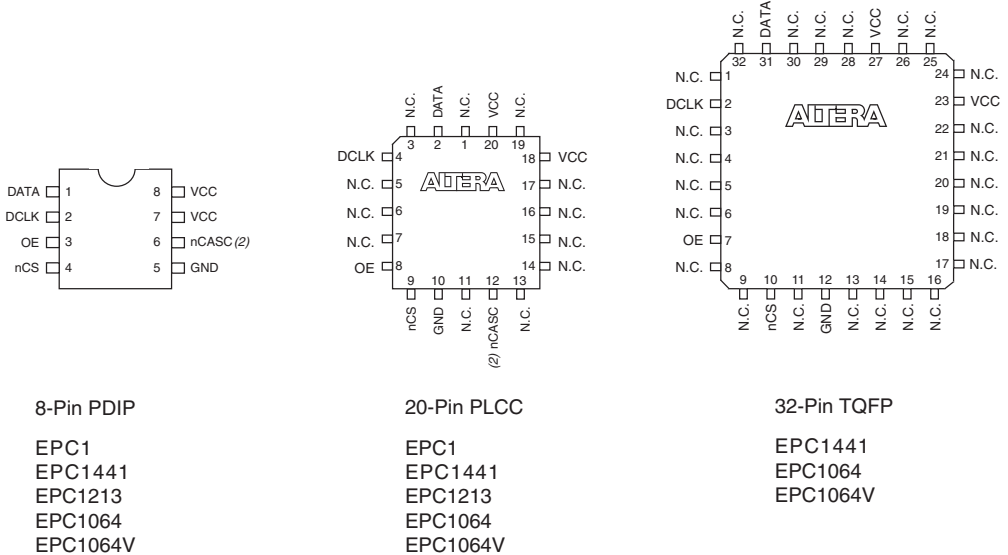

**Notes to Figure 5–6:**

- (1) EPC1 and EPC1441 devices are one-time programmable devices. ISP is not available in these devices.
- (2) The nCASC pin is available on EPC1 devices, which allows them to be cascaded. On the EPC1441 devices, nCASC is a reserved pin and should be left unconnected.

**Figure 5–7. EPC2 Package Pin-Out Diagrams**

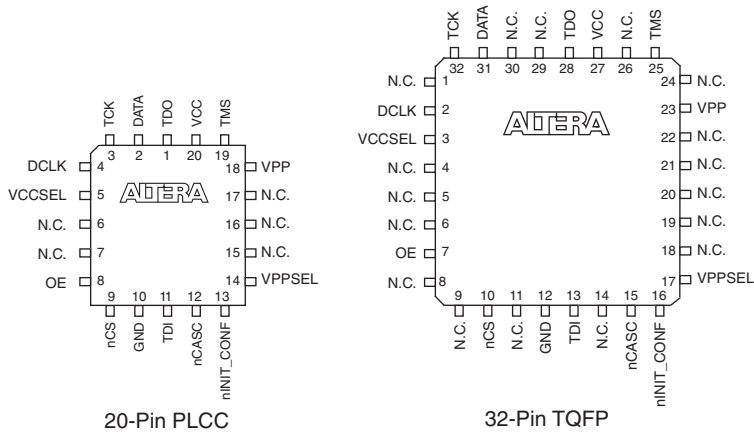

For package outlines and drawings, refer to the *Altera Device Package Information Data Sheet*.

## Ordering Codes

Table 5–21. shows the ordering codes for the EPC2, EPC1, and EPC1441 configuration devices.

<b>Device</b>	<b>Package</b>	<b>Temperature</b>	<b>Ordering Code</b>
EPC2	32-pin TQFP	Commercial	EPC2TC32
EPC2	32-pin TQFP	Industrial	EPC2TI32
EPC2	20-pin PLCC	Commercial	EPC2LC20
EPC2	20-pin PLCC	Industrial	EPC2LI20
EPC1	20-pin PLCC	Commercial	EPC1LC20
EPC1	20-pin PLCC	Industrial	EPC1LI20
EPC1	8-pin PDIP	Commercial	EPC1PC8
EPC1	8-pin PDIP	Industrial	EPC1PI8
EPC1441	32-pin TQFP	Commercial	EPC1441TC32
EPC1441	32-pin TQFP	Industrial	EPC1441TI32
EPC1441	20-pin PLCC	Commercial	EPC1441LC20
EPC1441	20-pin PLCC	Industrial	EPC1441LI20
EPC1441	8-pin PDIP	Commercial	EPC1441PC8
EPC1441	8-pin PDIP	Industrial	EPC1441PI8

## Document Revision History

Table 5–22 shows the revision history for this document.

<b>Date &amp; Document Version</b>	<b>Changes Made</b>	<b>Summary of Changes</b>
April 2007 v2.2	Added document revision history.	
July 2004 v2.0	Added Stratix II and Cyclone II device information throughout chapter.	
September 2003 v1.0	Initial Release.	