

Seven darlington array

Feature summary

- Seven darlington pairs per package
- Extended temperature range:
-40 to 105°C
- Output current 500mA per driver (600mA peak)
- Output voltage 50V
- Integrated suppression diodes for inductive loads
- Outputs can be paralleled for higher current
- TTL/CMOS/PMOS/DTL Compatible inputs
- Inputs pinned opposite outputs to simplify layout

Description

The ULQ2001, ULQ2003 and ULQ2004 are high voltage, high current darlington arrays each containing seven open collector darlington pairs with common emitters. Each channel rated at 500mA and can withstand peak currents of 600mA. Suppression diodes are included for inductive load driving and the inputs are pinned opposite the outputs to simplify board layout.

The versions interface to all common logic families.

Order code

Part numbers	Package
ULQ2001A	DIP-16
ULQ2003A	DIP-16
ULQ2004A	DIP-16
ULQ2001D1	SO16 (narrow)
ULQ2003D1	SO16 (narrow)
ULQ2004D1	SO16 (narrow)
ULQ2001D1013TR	SO16 in Tape & Reel
ULQ2003D1013TR	SO16 in Tape & Reel
ULQ2004D1013TR	SO16 in Tape & Reel

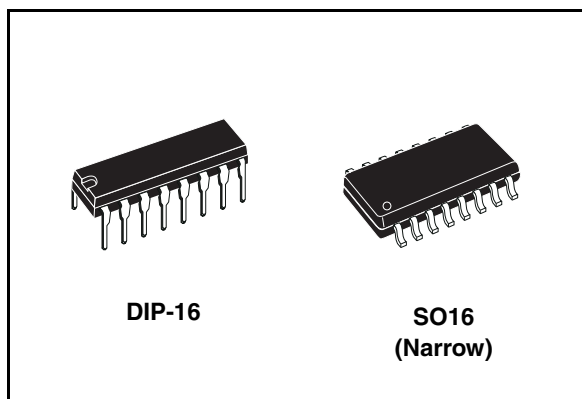

ULQ2001	General Purpose, DTL, TTL, PMOS, CMOS
ULQ2003	5V TTL, CMOS
ULQ2004	6–15V CMOS, PMOS

These versatile devices are useful for driving a wide range of loads including solenoids, relays DC motors, LED displays filament lamps, thermal printheads and high power buffers.

The ULQ2001A/2003A and 2004A are supplied in 16 pin plastic DIP packages with a copper leadframe to reduce thermal resistance. They are available also in small outline package (SO-16) as ULQ2001D1/2003D1/2004D1.

Contents

1	Diagram	3
2	Pin configuration	4
3	Maximum ratings	5
4	Electrical characteristics	6
5	Test circuits	7
6	Package mechanical data	9
7	Revision history	12

1 Diagram

Figure 1. Schematic diagram

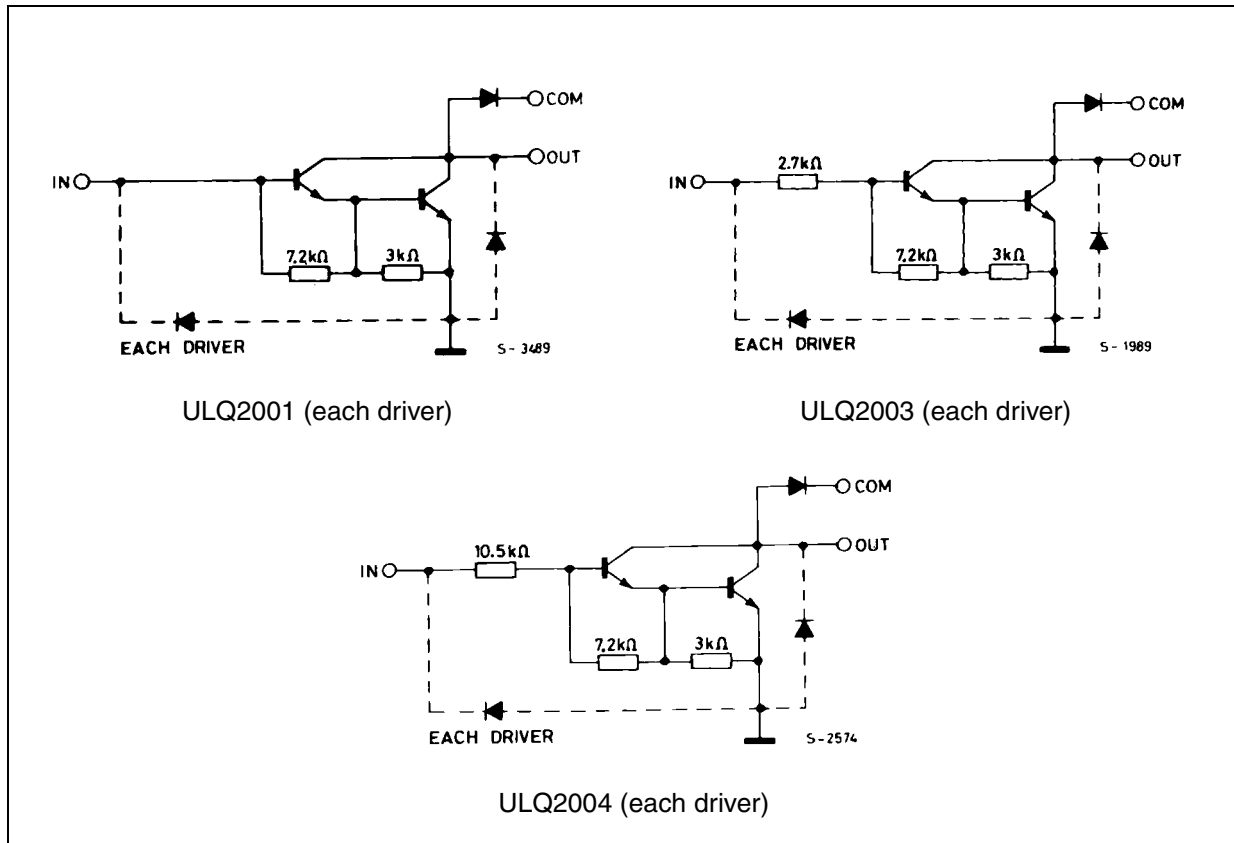

2 Pin configuration

Figure 2. Pin connections (top view)

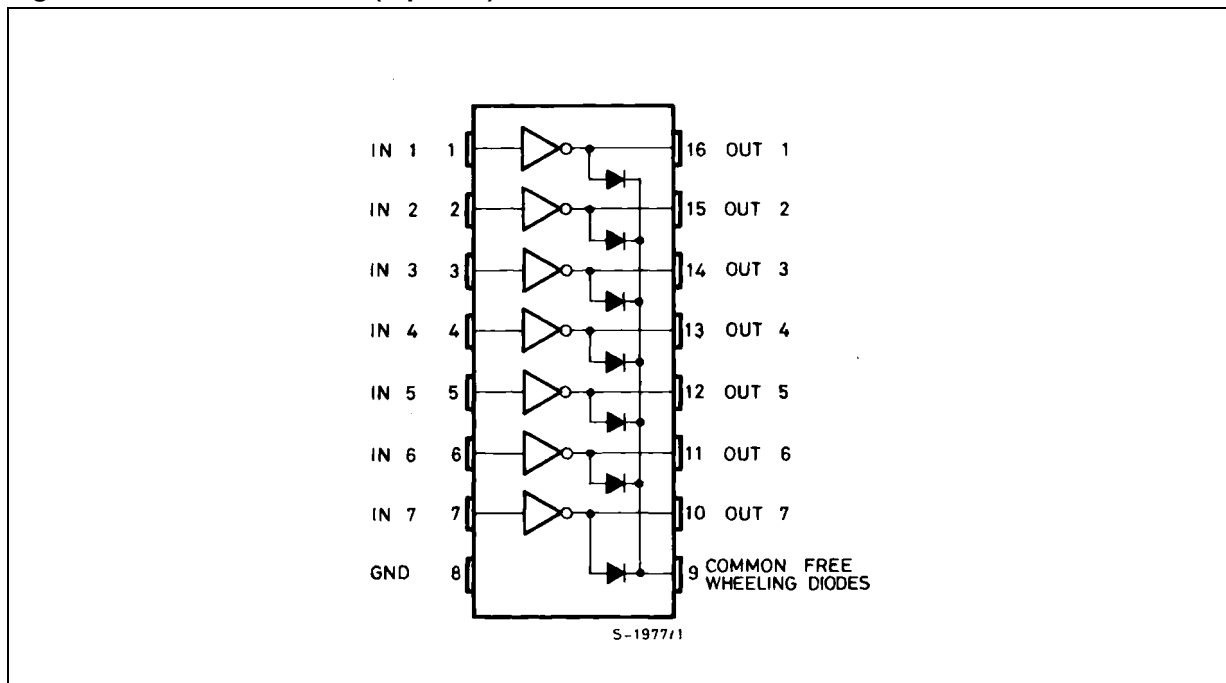

3 Maximum ratings

Table 1. Absolute maximum ratings

Symbol	Parameter	Value	Unit
V_o	Output voltage	50	V
V_{in}	Input voltage (for ULQ2003A/D1 - 2004A/D1)	30	V
I_c	Continuous collector current	500	mA
I_b	Continuous base current	25	mA
T_A	Operating ambient temperature range	-40 to 105	°C
T_{STG}	Storage temperature range	-55 to 150	°C
T_J	Junction temperature	150	°C

Table 2. Thermal Data

Symbol	Parameter	DIP-16	SO-16	Unit
R_{thJA}	Thermal resistance junction-ambient, Max.	70	120	°C/W

4 Electrical characteristics

Table 3. Electrical characteristics
 ($T_A = -40$ to 105°C for DIP16 unless otherwise specified)
 ($T_J = 25$ to 105°C for SO16 unless otherwise specified).

Symbol	Parameter	Test	Min.	Typ.	Max.	Unit
I_{CEX}	Output leakage current	$V_{\text{CE}} = 50\text{V}$, (Figure 3.)			50	μA
		$T_A = 105^\circ\text{C}$, $V_{\text{CE}} = 50\text{V}$ (Figure 3.)			100	
		$T_J = 105^\circ\text{C}$ for ULQ2004, $V_{\text{CE}} = 50\text{V}$, $V_I = 1\text{V}$ (Figure 4.)			500	
$V_{\text{CE(SAT)}}$	Collector-emitter saturation voltage (Figure 5.)	$I_C = 100\text{mA}$, $I_B = 250\mu\text{A}$		0.9	1.1	V
		$I_C = 200\text{mA}$, $I_B = 350\mu\text{A}$		1.1	1.3	
		$I_C = 350\text{mA}$, $I_B = 500\mu\text{A}$		1.3	1.6	
$I_{\text{I(ON)}}$	Input current (Figure 6.)	for ULQ2003, $V_I = 3.85\text{V}$		0.93	1.35	mA
		for ULQ2004, $V_I = 5\text{V}$		0.35	0.5	
		$V_I = 12\text{V}$		1	1.45	
$I_{\text{I(OFF)}}$	Input current (Figure 7.)	$T_A = 105^\circ\text{C}$, $I_C = 500\mu\text{A}$	50	65		μA
$V_{\text{I(ON)}}$	Input voltage (Figure 8.)	for ULQ2003			2.4	V
		$I_C = 200\text{mA}$			2.7	
		$I_C = 250\text{mA}$			3	
		$I_C = 300\text{mA}$				
		for ULQ2004			5	
		$I_C = 125\text{mA}$			6	
		$I_C = 200\text{mA}$			7	
$I_C = 275\text{mA}$			8			
h_{FE}	DC Forward current gain (Figure 5.)	for ULQ2001, $V_{\text{CE}} = 2\text{V}$, $I_C = 350\text{mA}$	1000			
C_I	Input capacitance			15	25 ⁽¹⁾	pF
t_{PLH}	Turn-on delay time	$0.5 V_I$ to $0.5 V_O$		0.25	1 ⁽¹⁾	μs
t_{PHL}	Turn-off delay time	$0.5 V_I$ to $0.5 V_O$		0.25	1 ⁽¹⁾	μs
I_{R}	Clamp diode leakage current (Figure 9.)	$V_{\text{R}} = 50\text{V}$			50	μA
		$T_A = 105^\circ\text{C}$, $V_{\text{R}} = 50\text{V}$			100	
V_{F}	Clamp diode forward voltage (Figure 10.)	$I_{\text{F}} = 350\text{mA}$		1.7	2	V

1. Guaranteed by design.

5 Test circuits

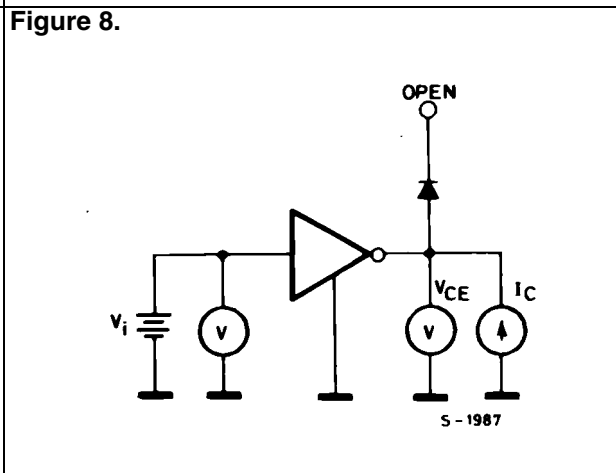
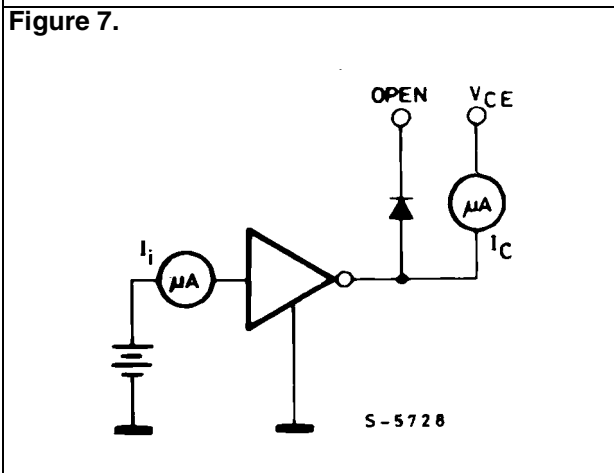
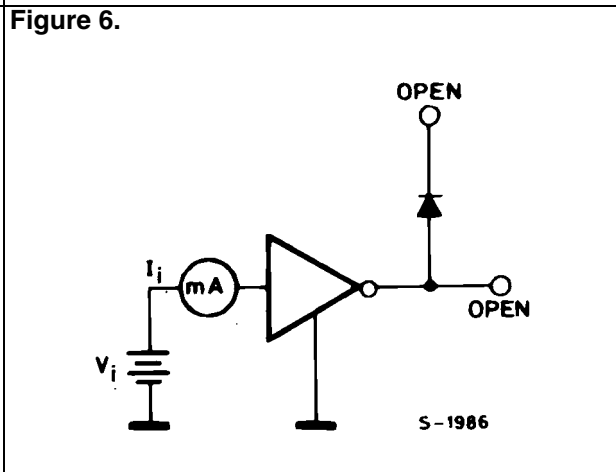
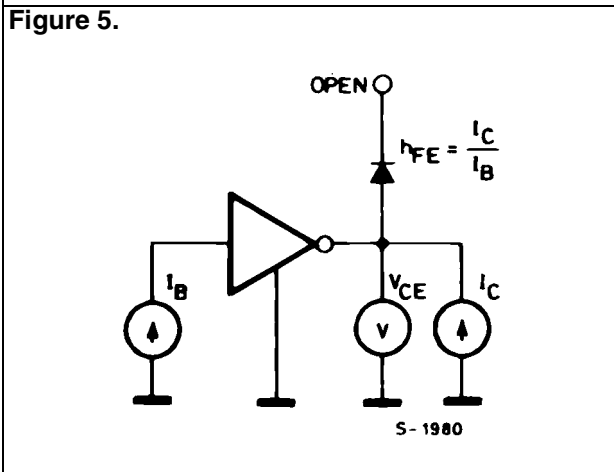
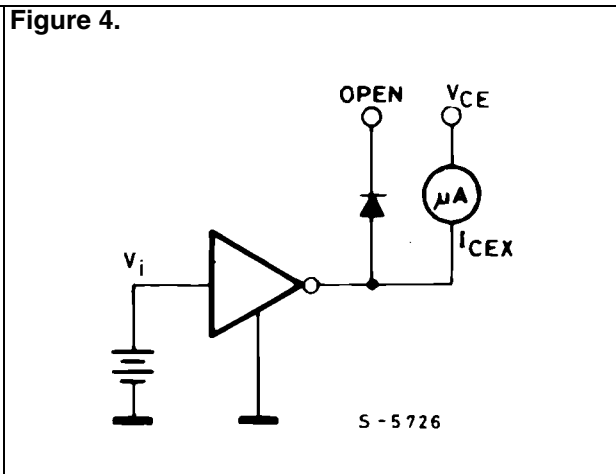
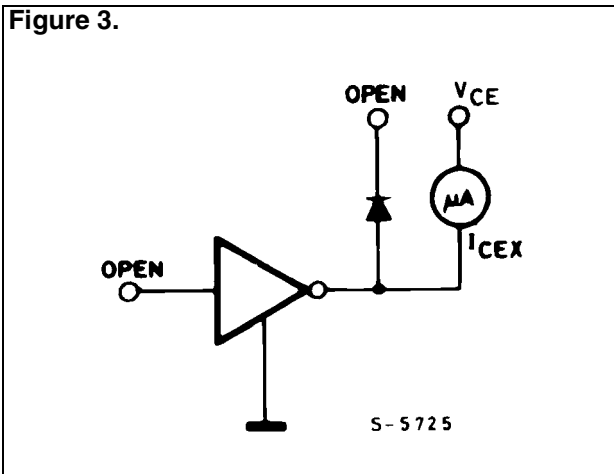

Figure 9.

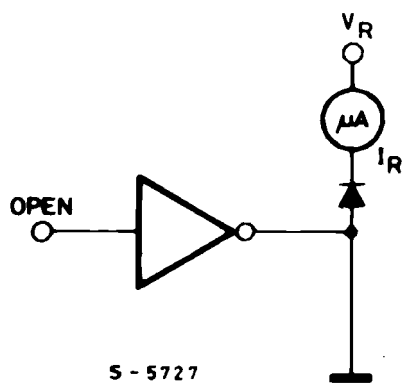
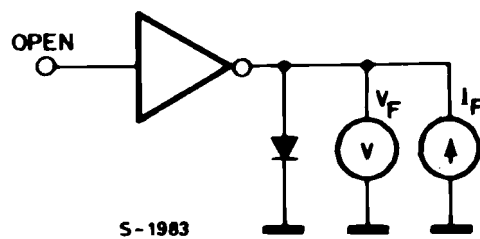

Figure 10.



6 Package mechanical data

In order to meet environmental requirements, ST offers these devices in ECOPACK® packages. These packages have a Lead-free second level interconnect. The category of second Level Interconnect is marked on the package and on the inner box label, in compliance with JEDEC Standard JESD97. The maximum ratings related to soldering conditions are also marked on the inner box label. ECOPACK is an ST trademark. ECOPACK specifications are available at: www.st.com.

Plastic DIP-16 (0.25) MECHANICAL DATA

DIM.	mm.			inch		
	MIN.	TYP	MAX.	MIN.	TYP.	MAX.
a1	0.51			0.020		
B	0.77		1.65	0.030		0.065
b		0.5			0.020	
b1		0.25			0.010	
D			20			0.787
E		8.5			0.335	
e		2.54			0.100	
e3		17.78			0.700	
F			7.1			0.280
I			5.1			0.201
L		3.3			0.130	
Z			1.27			0.050

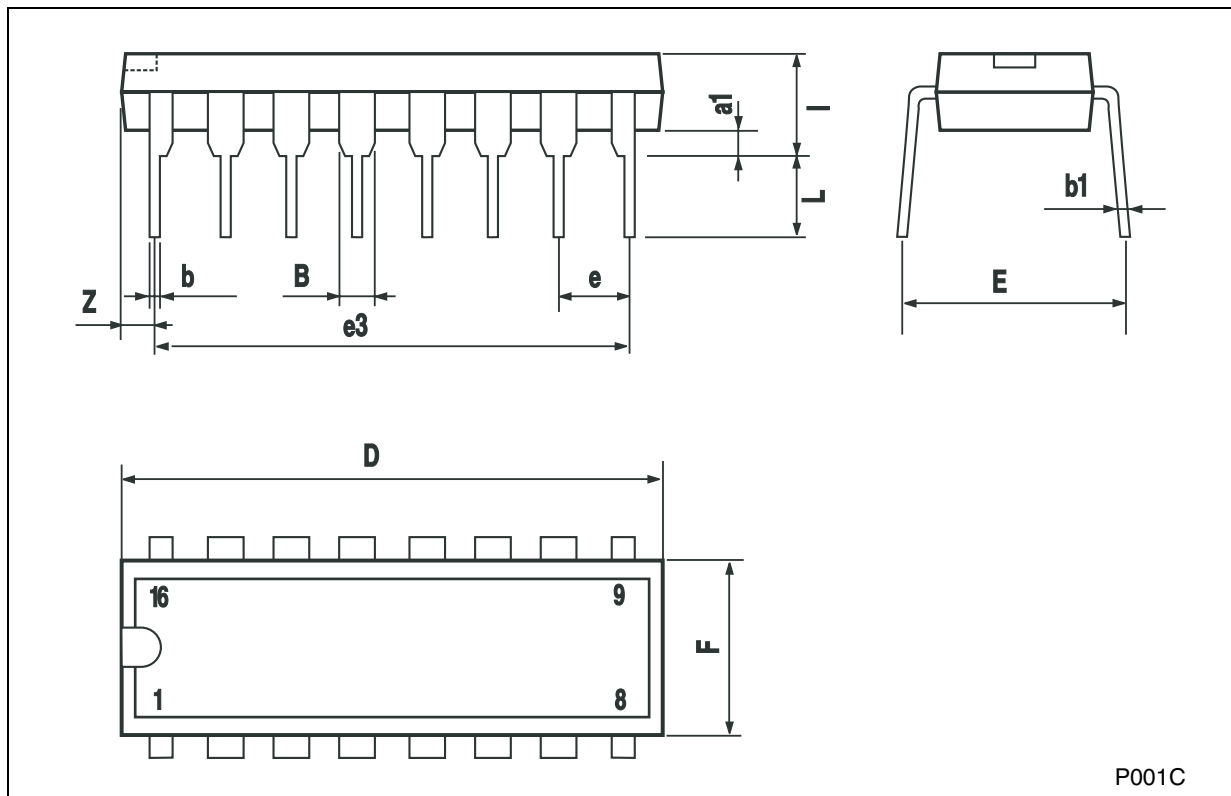

DIM.	mm			inch		
	MIN.	TYP.	MAX.	MIN.	TYP.	MAX.
A			1.75			0.069
a1	0.1		0.25	0.004		0.009
a2			1.6			0.063
b	0.35		0.46	0.014		0.018
b1	0.19		0.25	0.007		0.010
C		0.5			0.020	
c1			45°	(typ.)		
D ⁽¹⁾	9.8		10	0.386		0.394
E	5.8		6.2	0.228		0.244
e		1.27			0.050	
e3		8.89			0.350	
F ⁽¹⁾	3.8		4.0	0.150		0.157
G	4.60		5.30	0.181		0.208
L	0.4		1.27	0.150		0.050
M			0.62			0.024
S	8° (max.)					
(1) "D" and "E" do not include mold flash or protrusions - Mold flash or protrusions shall not exceed 0.15mm (.006inc.)						

OUTLINE AND MECHANICAL DATA

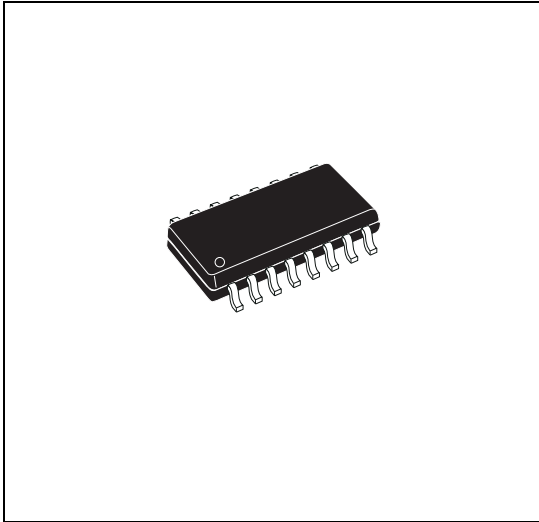

SO16 (Narrow)

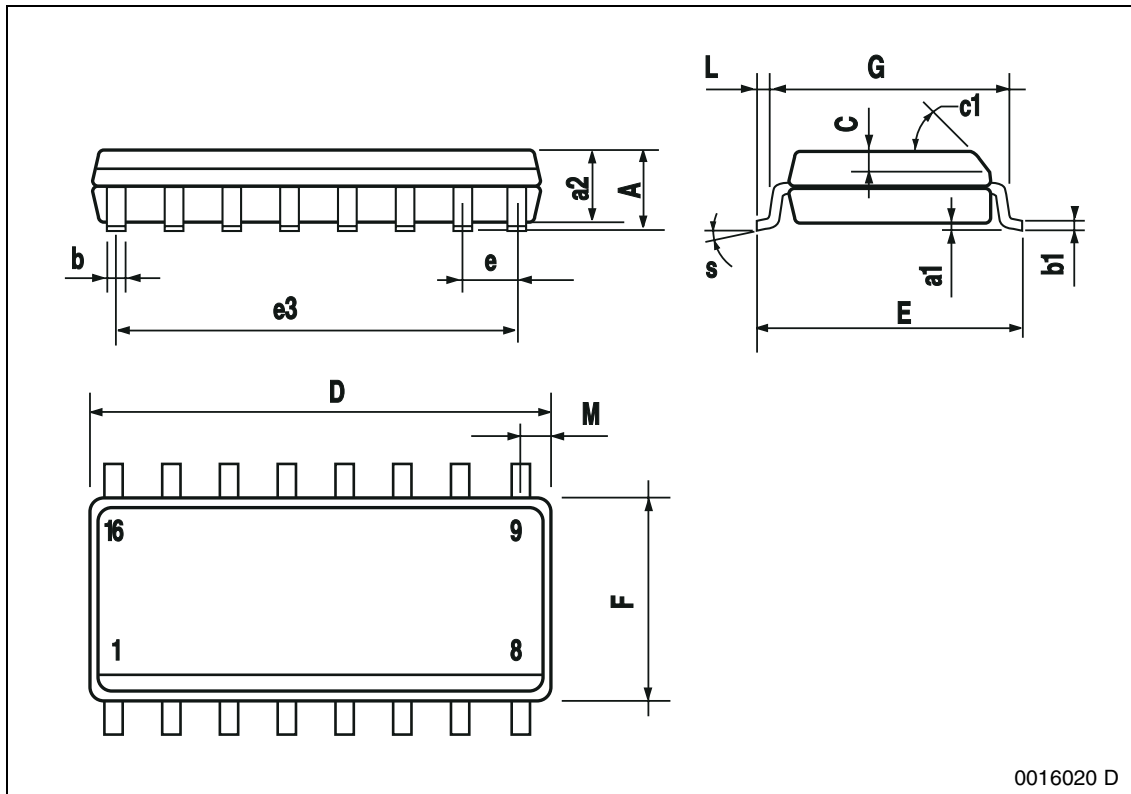

0016020 D

7 Revision history

Table 4. Revision history

Date	Revision	Changes
05-Dec-2006	2	Order codes has been updated and document has been reformatted.

Please Read Carefully:

Information in this document is provided solely in connection with ST products. STMicroelectronics NV and its subsidiaries ("ST") reserve the right to make changes, corrections, modifications or improvements, to this document, and the products and services described herein at any time, without notice.

All ST products are sold pursuant to ST's terms and conditions of sale.

Purchasers are solely responsible for the choice, selection and use of the ST products and services described herein, and ST assumes no liability whatsoever relating to the choice, selection or use of the ST products and services described herein.

No license, express or implied, by estoppel or otherwise, to any intellectual property rights is granted under this document. If any part of this document refers to any third party products or services it shall not be deemed a license grant by ST for the use of such third party products or services, or any intellectual property contained therein or considered as a warranty covering the use in any manner whatsoever of such third party products or services or any intellectual property contained therein.

UNLESS OTHERWISE SET FORTH IN ST'S TERMS AND CONDITIONS OF SALE ST DISCLAIMS ANY EXPRESS OR IMPLIED WARRANTY WITH RESPECT TO THE USE AND/OR SALE OF ST PRODUCTS INCLUDING WITHOUT LIMITATION IMPLIED WARRANTIES OF MERCHANTABILITY, FITNESS FOR A PARTICULAR PURPOSE (AND THEIR EQUIVALENTS UNDER THE LAWS OF ANY JURISDICTION), OR INFRINGEMENT OF ANY PATENT, COPYRIGHT OR OTHER INTELLECTUAL PROPERTY RIGHT.

UNLESS EXPRESSLY APPROVED IN WRITING BY AN AUTHORIZED ST REPRESENTATIVE, ST PRODUCTS ARE NOT RECOMMENDED, AUTHORIZED OR WARRANTED FOR USE IN MILITARY, AIR CRAFT, SPACE, LIFE SAVING, OR LIFE SUSTAINING APPLICATIONS, NOR IN PRODUCTS OR SYSTEMS WHERE FAILURE OR MALFUNCTION MAY RESULT IN PERSONAL INJURY, DEATH, OR SEVERE PROPERTY OR ENVIRONMENTAL DAMAGE. ST PRODUCTS WHICH ARE NOT SPECIFIED AS "AUTOMOTIVE GRADE" MAY ONLY BE USED IN AUTOMOTIVE APPLICATIONS AT USER'S OWN RISK.

Resale of ST products with provisions different from the statements and/or technical features set forth in this document shall immediately void any warranty granted by ST for the ST product or service described herein and shall not create or extend in any manner whatsoever, any liability of ST.

ST and the ST logo are trademarks or registered trademarks of ST in various countries.

Information in this document supersedes and replaces all information previously supplied.

The ST logo is a registered trademark of STMicroelectronics. All other names are the property of their respective owners.

© 2006 STMicroelectronics - All rights reserved

STMicroelectronics group of companies

Australia - Belgium - Brazil - Canada - China - Czech Republic - Finland - France - Germany - Hong Kong - India - Israel - Italy - Japan - Malaysia - Malta - Morocco - Singapore - Spain - Sweden - Switzerland - United Kingdom - United States of America

www.st.com