

双路桥式步进器或者直流 (DC) 电机驱动器

 查询样品: **DRV8834**

特性

- 双 H 桥电流控制电机驱动器
 - 能够驱动两个直流 (DC) 电机或者一个步进电机
- 两个控制模式:
 - 具有简单步长/方向控制和高达 **1/32** 步长微步进的内置分度器逻辑
 - 相位/使能控制, 能够驱动针对 **> 1/32** 步长微步进的外部基准
- 每个 H 桥的输出电流为持续 **1.5A**, **2.2A** 峰值电流 (在 $V_M = 5V$ 和 $25^\circ C$ 条件下)
- 低 R_{DS} (接通): **305mΩ HS + LS** (在 $V_M = 5V$ 和 $25^\circ C$ 条件下)
- **Wide Power Supply Voltage Range: 2.5 V – 10.8 V**
- 用于平滑微步进的动态 $t_{\text{空白}}$ 和混合衰减模式
- 脉宽调制 (PWM) 绕组电流调制和限制
- 散热增强型表面贴装封装

应用范围

- 电池供电式玩具
- 服务点 (POS) 打印机
- 视频安保摄像机
- 办公自动化设备
- 游戏机
- 机器人技术

说明

DRV8834 为玩具、打印机及其它机电一体化应用提供了一款灵活的电机驱动器解决方案。此器件有两个 H 桥驱动器, 并且被设计用于驱动一个双极步进电机或者两个 DC 电机。

每个 H 桥的输出驱动器模块由 N 通道功率 MOSFET 组成, 这些 MOSFET 被配置成一个驱动电机绕组的 H 桥。每个 H 桥都包括用于调节或限制绕组电流的电路。

借助正确的印刷电路板 (PCB) 设计, DRV8834 的每个 H 桥能够持续驱动高达 **1.5A RMS** (或 DC) (在 $25^\circ C$ 和采用一个 $5V V_M$ 电源时)。每个 H 桥可支持高达 **2.2A** 的峰值电流。在较低的 V_M 电压条件下, 电流能力略有下降。在较低的 V_M 电压条件下, 电流能力略有下降。

该器件提供了带有一个故障输出引脚的内部关断功能, 此功能用于过流保护、短路保护、欠压闭锁和过热。另外, 还提供了一种低功耗睡眠模式。

DRV8834 采用带有 PowerPAD 的 24 引脚散热式薄型小外形尺寸封装 (HTSSOP) 或者超薄四方扁平无引线 (VQFN) 封装。TM (环保型: 符合 RoHS 标准且不含 Sb/Br)。

ORDERING INFORMATION⁽¹⁾

PACKAGE ⁽²⁾		ORDERABLE PART NUMBER	TOP-SIDE MARKING
PowerPAD TM (HTSSOP) - PWP	Reel of 2000	DRV8834PWPR	DRV8834
	Tube of 60	DRV8834PWP	
PowerPAD TM (VQFN) - RGE	Reel of 3000	DRV8834RGER	8834
	Reel of 250	DRV8834RGET	

(1) For the most current packaging and ordering information, see the Package Option Addendum at the end of this document, or see the TI web site at www.ti.com.

(2) Package drawings, thermal data, and symbolization are available at www.ti.com/packaging.



Please be aware that an important notice concerning availability, standard warranty, and use in critical applications of Texas Instruments semiconductor products and disclaimers thereto appears at the end of this data sheet.

24 引脚散热式薄型小外形尺寸封装 (HTSSOP) 或者超薄四方扁平无引线 (VQFN) 封装。PowerPAD are trademarks of Texas Instruments.

DEVICE INFORMATION
Functional Block Diagram

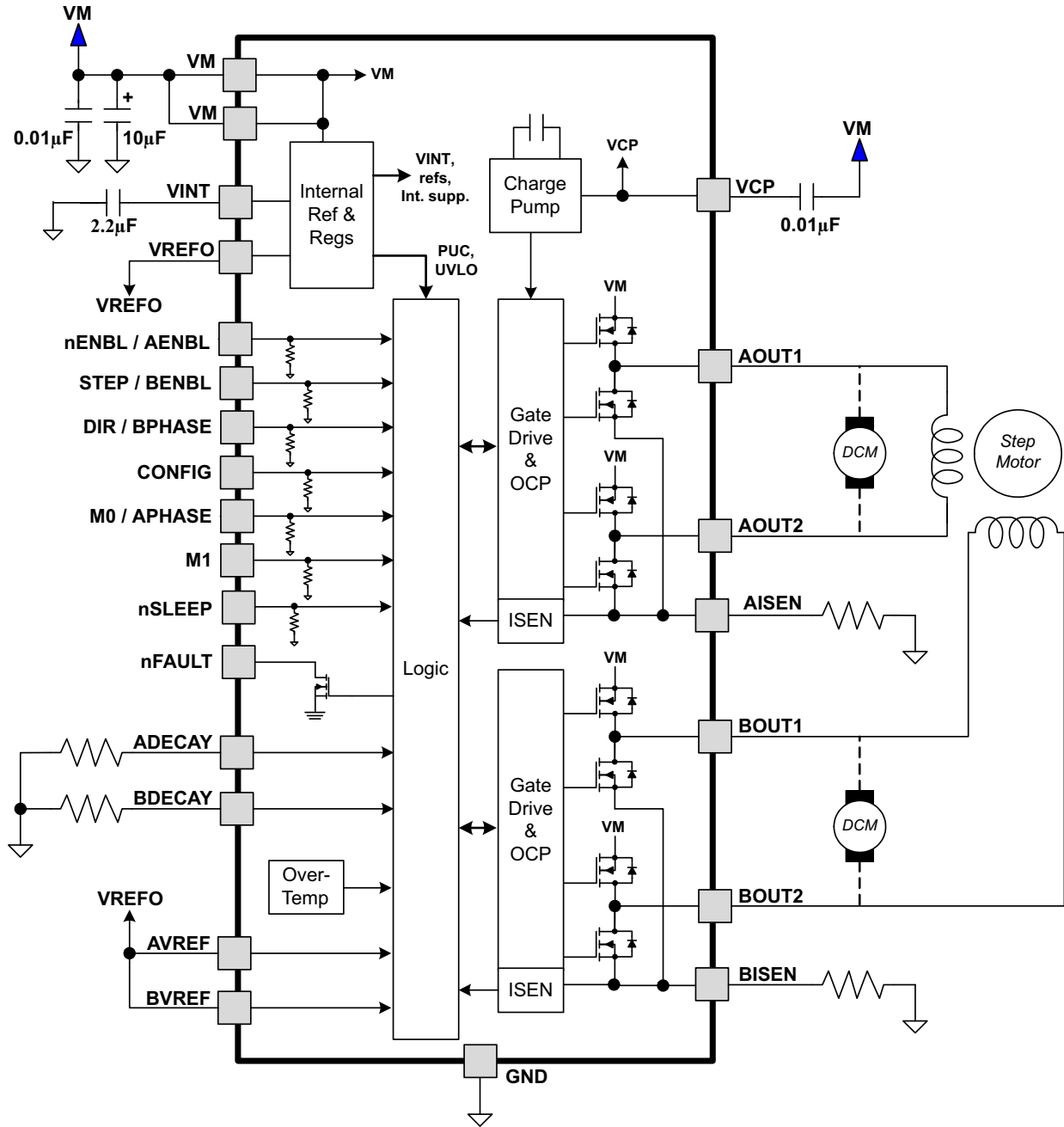

Table 1. TERMINAL FUNCTIONS

NAME	PIN (PWP)	PIN (RGE)	I/O ⁽¹⁾	DESCRIPTION	EXTERNAL COMPONENTS OR CONNECTIONS
POWER AND GROUND					
GND	21, PPAD	18, PPAD	-	Device ground	Both the GND pin and device PowerPAD must be connected to ground
VM	18, 19	15, 16	-	Bridge A power supply	Connect to motor supply. A 10- μ F (minimum) capacitor to GND is recommended.
VINT	20	17	-	Internal supply	Bypass to GND with 2.2- μ F (minimum), 6.3-V capacitor. Can be used to provide logic high voltage for configuration pins (except nSLEEP).
VREFO	24	21	O	Reference voltage output	May be connected to AVREF/BVREF inputs. Do not place a bypass capacitor on this pin.
VCP	17	14	O	High-side gate drive voltage	Connect a 0.01- μ F, 16-V (minimum) X7R ceramic capacitor to VM.
CONTROL (Indexer Mode or Phase/Enable Mode)					
nENBL/AENBL	10	7	I	Step motor enable/Bridge A enable	Indexer mode: Logic low enables all outputs. Phase/enable mode: Logic low enables the AOUTx outputs. Internal pull-down.
STEP/BENBL	11	8	I	Step input/Bridge B enable	Indexer mode: Rising edge moves indexer to next step. Phase/enable mode: Logic low enables the BOUTx outputs. Internal pull-down.
DIR/BPHASE	12	9	I	Direction input/Bridge B Phase	Indexer mode: Level sets direction of step. Phase/enable mode: Logic high sets BOUT1 high, BOUT2 low. Internal pull-down.
M0/APHASE	13	10	I	Microstep mode/Bridge A phase	Indexer mode: Controls microstep mode (full, half, up to 1/32-step) along with M1. Phase/enable mode: Logic high sets AOUT1 high, AOUT2 low. Internal pull-down.
M1	14	11	I	Microstep mode/Disable state	Indexer mode: Controls microstep mode (full, half, up to 1/32-step) along with M0. Phase/enable mode: Determines the state of the outputs when xENBL = 0. Internal pull-down.
CONFIG	15	12	I	Device configuration	Logic high to put the device in indexer mode. Logic low to put the device into phase/enable mode. State is latched at power-up and sleep exit. Internal pull-down.
nSLEEP	1	22	I	Sleep mode input	Logic high to enable device, logic low to enter low-power sleep mode and reset all internal logic.
AVREF	22	19	I	Bridge A current set reference input	Reference voltage for winding current set. Can be driven individually with an external DACs for micro-stepping, or tied to a reference voltage (e.g., VREFO).
BVREF	23	20	I	Bridge B current set reference input	Reference voltage for winding current set. Can be driven individually with an external DACs for micro-stepping, or tied to a reference voltage (e.g., VREFO).
ADECAY	3	24	I	Decay mode for bridge A	Determines decay mode for H-Bridge A (or A and B in indexer mode) – slow, fast or mixed decay
BDECAY	2	23	I	Decay mode for bridge B	Determines decay mode for H-Bridge B – slow, fast or mixed decay

(1) Directions: I = input, O = output, OZ = tri-state output, OD = open-drain output, IO = input/output

Table 1. TERMINAL FUNCTIONS (continued)

NAME	PIN (PWP)	PIN (RGE)	I/O ⁽¹⁾	DESCRIPTION	EXTERNAL COMPONENTS OR CONNECTIONS
STATUS					
nFAULT	16	13	OD	Fault output	Logic low when in fault condition (overtemp, overcurrent, undervoltage)
OUTPUT					
AISEN	5	2	IO	Bridge A ground/Isense	Connect to current sense resistor for bridge A, or GND if current control not needed
BISEN	8	5	IO	Bridge B ground/Isense	Connect to current sense resistor for bridge B, or GND if current control not needed
AOUT1	4	1	O	Bridge A output 1	Connect to motor winding A
AOUT2	6	3	O	Bridge A output 2	
BOUT1	9	6	O	Bridge B output 1	Connect to motor winding B
BOUT2	7	4	O	Bridge B output 2	

PWP PACKAGE (TOP VIEW)

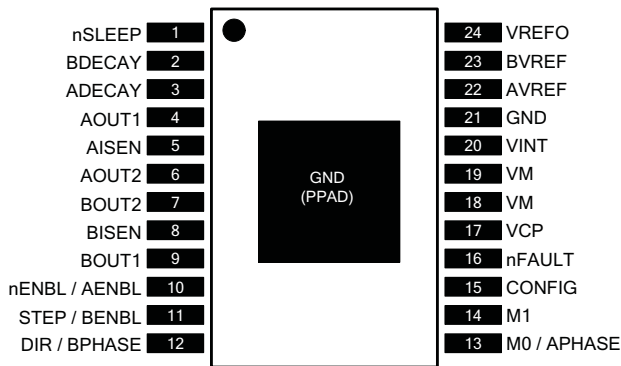

RGE PACKAGE (TOP VIEW)

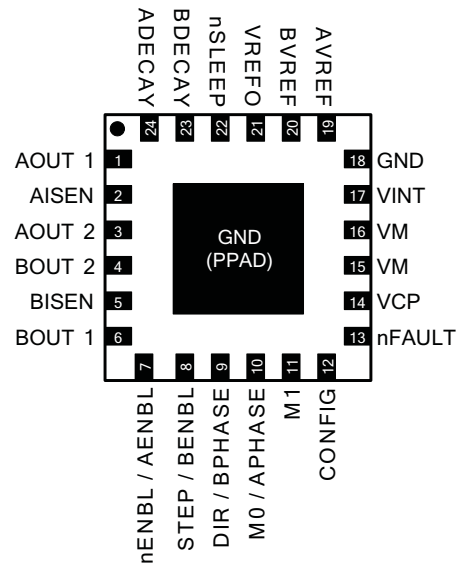

ABSOLUTE MAXIMUM RATINGS

over operating free-air temperature range (unless otherwise noted) ⁽¹⁾ ⁽²⁾

		VALUE	UNIT
V _M	Power supply voltage range	-0.3 to 11.8	V
AVREF, BVREF, VINT, ADECAY, BDECAY	Analog input pin voltage range	-0.5 to 3.6	V
	Digital input pin voltage range	-0.5 to 7	V
	xISEN pin voltage	-0.3 to 0.5	V
	Peak motor drive output current, t < 1 μs	Internally limited	A
T _J	Operating virtual junction temperature range	-40 to 150	°C
T _{stg}	Storage temperature range	-60 to 150	°C

- Stresses beyond those listed under absolute maximum ratings may cause permanent damage to the device. These are stress ratings only, and functional operation of the device at these or any other conditions beyond those indicated under recommended operating conditions is not implied. Exposure to absolute-maximum-rated conditions for extended periods may affect device reliability.
- All voltage values are with respect to network ground terminal.

THERMAL INFORMATION

THERMAL METRIC		PWP	RGE	UNITS
		24 PINS	24 PINS	
θ _{JA}	Junction-to-ambient thermal resistance ⁽¹⁾	40.2	35.1	°C/W
θ _{JCtop}	Junction-to-case (top) thermal resistance ⁽²⁾	23.7	36.6	
θ _{JB}	Junction-to-board thermal resistance ⁽³⁾	21.9	12.2	
ψ _{JT}	Junction-to-top characterization parameter ⁽⁴⁾	0.7	0.6	
ψ _{JB}	Junction-to-board characterization parameter ⁽⁵⁾	21.7	12.2	
θ _{JCbot}	Junction-to-case (bottom) thermal resistance ⁽⁶⁾	3.9	4.0	

- The junction-to-ambient thermal resistance under natural convection is obtained in a simulation on a JEDEC-standard, high-K board, as specified in JESD51-7, in an environment described in JESD51-2a.
- The junction-to-case (top) thermal resistance is obtained by simulating a cold plate test on the package top. No specific JEDEC-standard test exists, but a close description can be found in the ANSI SEMI standard G30-88.
- The junction-to-board thermal resistance is obtained by simulating in an environment with a ring cold plate fixture to control the PCB temperature, as described in JESD51-8.
- The junction-to-top characterization parameter, ψ_{JT}, estimates the junction temperature of a device in a real system and is extracted from the simulation data for obtaining θ_{JA}, using a procedure described in JESD51-2a (sections 6 and 7).
- The junction-to-board characterization parameter, ψ_{JB}, estimates the junction temperature of a device in a real system and is extracted from the simulation data for obtaining θ_{JA}, using a procedure described in JESD51-2a (sections 6 and 7).
- The junction-to-case (bottom) thermal resistance is obtained by simulating a cold plate test on the exposed (power) pad. No specific JEDEC standard test exists, but a close description can be found in the ANSI SEMI standard G30-88.

RECOMMENDED OPERATING CONDITIONS

T_A = 25°C, over operating free-air temperature range (unless otherwise noted)

		MIN	NOM	MAX	UNIT
V _M	Motor power supply voltage range ⁽¹⁾	2.5		10.8	V
V _{REF}	VREF input voltage range ⁽²⁾	1		2	V
I _{VINT}	VINT external load current			1	mA
I _{VREF}	VREF external load current			400	μA
V _{DIGIN}	Digital input pin voltage range	-0.3		5.75	V
I _{OUT}	Continuous RMS or DC output current per bridge ⁽³⁾			1.5	A

- Note that R_{DS(ON)} increases and maximum output current is reduced at V_M supply voltages below 5 V.
- Operational at VREF between 0 V and 1 V, but accuracy is degraded.
- Power dissipation and thermal limits must be observed.

ELECTRICAL CHARACTERISTICS

T_A = 25°C, over operating free-air temperature range (unless otherwise noted)

PARAMETER		TEST CONDITIONS	MIN	TYP	MAX	UNIT
POWER SUPPLY						
I _{VM}	VM operating supply current	V _M = 5 V, excluding winding current		2.4	4	mA
		V _M = 10 V, excluding winding current		2.75		
I _{VMQ}	VM sleep mode supply current	V _M = 5 V		0.6	2	μA
		V _M = 10 V		9.6		
V _{UVLO}	VM undervoltage lockout voltage	V _M falling			2.39	V
INTERNAL REGULATORS						
V _{INT}	VINT voltage	V _M > 3.3 V, I _{OUT} = 0 A to 1 mA	2.85	3	3.15	V
V _{REFO}	VREF voltage	I _{OUT} = 0 A to 400 μA	1.9	2	2.1	V
LOGIC-LEVEL INPUTS						
V _{IL}	Input low voltage	nSLEEP			0.5	V
		All other digital input pins			0.7	
V _{IH}	Input high voltage	nSLEEP	2.5			V
		All other digital input pins	2			
V _{HYS}	Input hysteresis	nSLEEP		0.2		V
		All except nSLEEP		0.4		
R _{PD}	Input pull-down resistance	nSLEEP		500		kΩ
		All except nSLEEP, M0		200		
I _{IL}	Input low current	V _{IN} = 0			1	μA
I _{IN}	Input current (M0)		-20		20	μA
I _{IH}	Input high current	V _{IN} = 3.3 V, nSLEEP		6.6	13	μA
		V _{IN} = 3.3 V, all except nSLEEP		16.5	33	
t _{DEG}	Input deglitch time		312		468	ns
nFAULT OUTPUT (OPEN-DRAIN OUTPUT)						
V _{OL}	Output low voltage	I _O = 5 mA			0.5	V
I _{OH}	Output high leakage current	V _O = 3.3 V			1	μA
H-BRIDGE FETS						
R _{DS(ON)}	HS FET on resistance	V _M = 5 V, I _O = 500 mA, T _J = 25°C		160	250	mΩ
		V _M = 5 V, I _O = 500 mA, T _J = 85°C		190		
		V _M = 2.7 V, I _O = 500 mA, T _J = 25°C		200	295	
		V _M = 2.7 V, I _O = 500 mA, T _J = 85°C		240		
	LS FET on resistance	V _M = 5 V, I _O = 500 mA, T _J = 25°C		145	240	
		V _M = 5 V, I _O = 500 mA, T _J = 85°C		180		
		V _M = 2.7 V, I _O = 500 mA, T _J = 25°C		190	285	
		V _M = 2.7 V, I _O = 500 mA, T _J = 85°C		235		
I _{OFF}	Off-state leakage current		-2		2	μA
MOTOR DRIVER						
f _{PWM}	Current control PWM frequency	Internal PWM frequency		42.5		kHz
t _{BLANK}	Current sense blanking time	V _{REF} > 375 mV or DAC codes > 29%		2.4		μs
		V _{REF} < 375 mV or DAC codes < 29%		1.6		
t _R	Rise time	V _M = 5 V, 16 Ω to GND, 10% to 90% V _M		120		ns
t _F	Fall time	V _M = 5 V, 16 Ω to GND, 10% to 90% V _M		100		ns
PROTECTION CIRCUITS						
I _{OC}	Overcurrent protection trip level		2			A
t _{OC}	Overcurrent protection period	V _{REF} > 375 mV or DAC codes > 29%		1.6		μs
		V _{REF} < 375 mV or DAC codes < 29%		1.1		

ELECTRICAL CHARACTERISTICS (continued)

T_A = 25°C, over operating free-air temperature range (unless otherwise noted)

PARAMETER		TEST CONDITIONS	MIN	TYP	MAX	UNIT
t _{TSD}	Thermal shutdown temperature	Die temperature	150	160	180	°C
CURRENT CONTROL						
I _{REF}	VREF input current	VREF = 3.3 V	-1		1	µA
V _{TRIP}	xISEN trip voltage	For 100% current step		400		mV
A _{ISENSE}	Current sense amplifier gain	Reference only		5		V/V

TIMING REQUIREMENTS

T_A = 25°C, over operating free-air temperature range (unless otherwise noted)

NO.	PARAMETER	CONDITIONS	MIN	MAX	UNIT
1	f _{STEP}	Step frequency		250	kHz
2	t _{WH(STEP)}	Pulse duration, STEP high	1.9		µs
3	t _{WL(STEP)}	Pulse duration, STEP low	1.9		µs
4	t _{SU(STEP)}	Setup time, command to STEP rising	200		ns
5	t _{H(STEP)}	Hold time, command to STEP rising	1		µs
6	t _{WAKE}	Wakeup time, nSLEEP inactive to STEP		1	ms

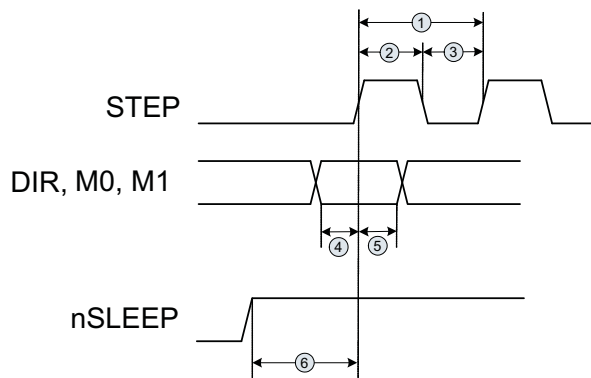

FUNCTIONAL DESCRIPTION

Device Configuration

The DRV8834 supports two configurations: phase/enable mode, where the outputs are controlled by phase (direction) and enable signals for each H-bridge, and indexer mode, which allow control of a stepper motor using simple step and direction inputs.

DC motors can only be controlled in phase/enable mode; indexer mode is not applicable to DC motors.

Stepper motors can be controlled using either phase/enable load, or indexer mode.

The device is configured to be controlled either way using CONFIG pin. Logic HIGH on the CONFIG pin puts the device in the STEP/DIR mode; logic LOW lets the motor to be controlled using the xPHASE/xENBL pins.

The state of the CONFIG pin is latched at power-up, and also whenever exiting sleep mode. CONFIG has an internal pull-down resistor.

PWM Motor Drivers

DRV8834 contains two identical H-bridge motor drivers with current-control PWM circuitry. A block diagram of the circuitry is shown below:

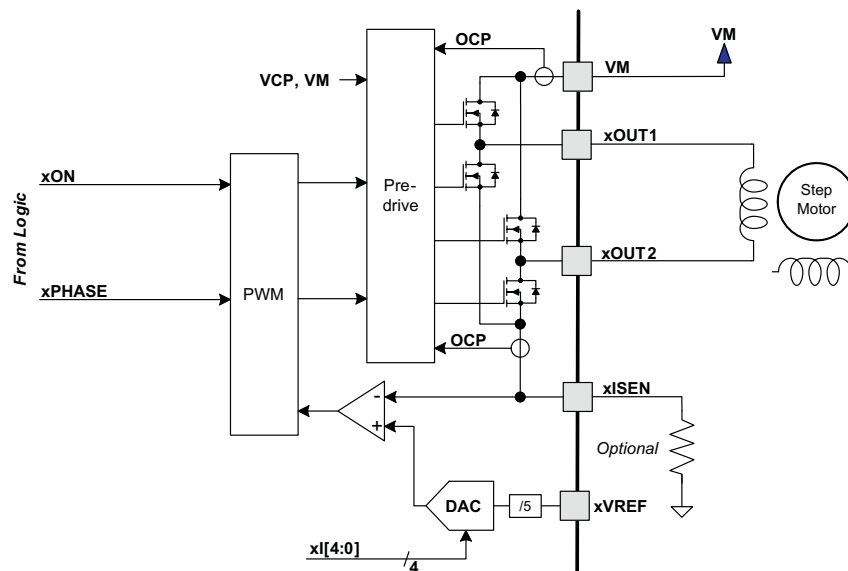

Figure 1. Motor Control Circuitry

Current Control

The current through the motor windings may be regulated by a fixed-frequency PWM current regulation, or current chopping.

With stepping motors, current control is normally used at all times. Often it is used to vary the current in the two windings in a sinusoidal fashion to provide smooth motion. This is referred to as microstepping. The DRV8834 can provide up to 1/32 step microstepping, using internal 5-bit DACs. Finer microstepping can be implemented using the xPHASE/xENBL signals to control the stepper motor, and varying the xVREF voltages. The current flowing through the corresponding H-bridge varies according to the equation given below. A very high degree of microstepping can be achieved through this technique.

With DC motors, current control can be used to limit the start-up current of the motor to less than the stall current of the motor.

Current regulation works as follows:

When an H-bridge is enabled, current rises through the winding at a rate dependent on the supply voltage and inductance of the winding. If the current reaches the current chopping threshold, the bridge disables the current until the beginning of the next PWM cycle. Note that immediately after the current is enabled, the voltage on the xISEN pin is ignored for a period of time before enabling the current sense circuitry. This blanking time also sets the minimum on time of the PWM when operating in current chopping mode.

Note that the blanking time also sets the minimum PWM duty cycle. This can cause current control errors near the zero current level when microstepping. To help eliminate this error, the DRV8834 has a "dynamic" t_{BLANK} time. When the commanded current is low, the blanking period is reduced, which in turn lowers the minimum duty cycle. This provides a smoother current transition across the zero crossing region of the current waveform. The end result is smoother and quieter motor operation.

The PWM chopping current is set by a comparator which compares the voltage across a current sense resistor connected to the xISEN pins, with a reference voltage supplied to the AVREF and BVREF pins. In indexer mode, the reference voltages are scaled by internal DACs to provide scaled currents used to perform microstepping.

The chopping current is calculated as follows:

$$I_{CHOP} = \frac{xVREF}{5 \cdot R_{ISENSE}} \quad (1)$$

Example: If xVREF is 2 V (as it would be if xVREF is connected directly to VREF0) and a 400-mΩ sense resistor is used, the chopping current will be $2 \text{ V} / 5 \times 400 \text{ m}\Omega = 1 \text{ A}$.

In indexer mode, this current value is scaled by between 5% and 100% by the internal DACs, as shown in the step table in the "Microstepping Indexer" section of the datasheet.

Note that if current control is not needed, the xISEN pins may be connected directly to ground. In this case it is also recommended to connect AVREF and BVREF directly to VREF0.

Current Recirculation and Decay Modes

During PWM current chopping, the H-bridge is enabled to drive current through the motor winding until the PWM current chopping threshold is reached. This is shown in [Figure 2](#) as case 1. The current flow direction shown indicates positive current flow in the step table below for indexer mode, or the current flow with xPHASE = 1 in phase/enable mode.

Once the chopping current threshold is reached, the drive current is interrupted, but due to the inductive nature of the motor, the current must continue to flow. This is called recirculation current. To handle this recirculation current, the H-bridge can operate in two different states, fast decay or slow decay.

In fast decay mode, once the PWM chopping current level has been reached, the H-bridge reverses state to allow winding current to flow in through the opposing FETs. As the winding current approaches zero, the bridge is disabled to prevent any reverse current flow. Fast decay mode is shown in [Figure 2](#) as case 2.

In slow decay mode, winding current is re-circulated by enabling both of the low-side FETs in the bridge. This is shown as case 3 below.

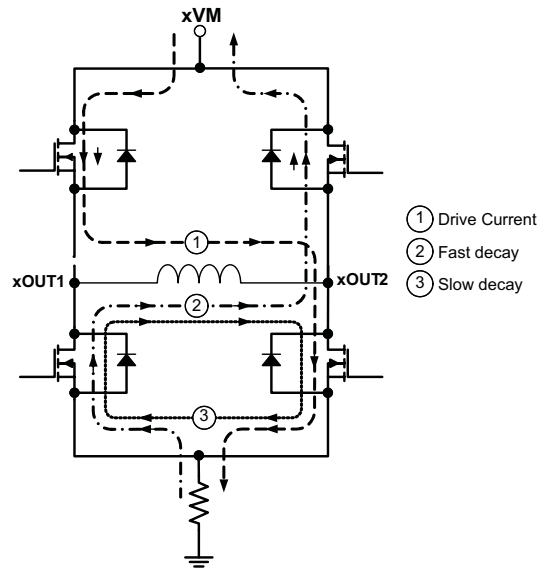

Figure 2. Decay Modes

The DRV8834 supports fast, slow, and also mixed decay modes. With DC motors, slow decay is nearly always used to minimize current ripple and optimize speed control; with stepper motors, the decay mode is chosen for a given stepper motor and operating conditions to minimize mechanical noise and vibration.

In mixed decay mode, the current recirculation begins as fast decay, but at a fixed period of time (determined by the state of the xDECAY pins shown in [Table 2](#)) switches to slow decay mode for the remainder of the fixed PWM period.

Table 2. Decay Pin Configuration

RESISTANCE ON xDECAY PIN	-OR- VOLTAGE FORCED ON xDECAY PIN	% OF PWM CYCLE IS FAST DECAY
< 1 kΩ	< 0.1 V	0%
20 kΩ ±5%	0.2 V ±5%	25%
50 kΩ ±5%	0.5 V ±5%	50%
100 kΩ ±5%	1 V ±5%	75%
kΩ	> 2 V	100%

Figure 3 illustrates the current waveforms in slow, fast, and 25% and 75% mixed decay modes.

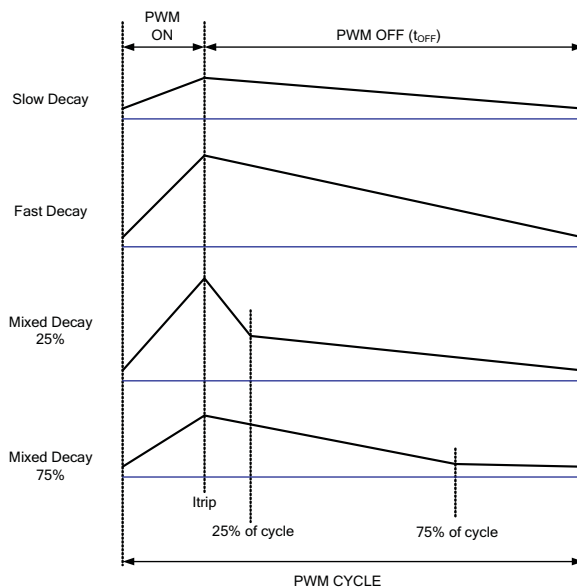

Figure 3. PWM Cycle

Decay mode is selected by the voltage present on the xDECAY pins. Internal current sources of 10 μA (typical) are connected to the pins, which allows setting of the decay mode by a resistor connected to ground if desired.

It is possible to drive the xDECAY pin with a tri-state GPIO pin and also place the resistor to ground. This allows a microcontroller to select fast, slow, or mixed decay modes by driving the pin high, low, or high-impedance. Note that the logic-low voltage must be less than 0.1 V with 10- μA of current sourced from the DRV8834 to attain slow decay.

In indexer mode, only the ADECAY pin is used, and slow decay mode is always used when at any point in the step table where the current is increasing. When current is decreasing or remaining constant, the decay mode used will be fast, slow, or mixed, as commanded by the ADECAY pin.

Phase/Enable Mode

In phase/enable mode, the xPHASE input pins control the direction of current flow through each H-bridge. This sets the direction of rotation of a DC motor, or the direction of the current flow in a stepper motor winding. Driving the xENBL input pins active high enables the H-bridge outputs. This can be used as PWM speed control of a DC motor, or to enable/disable the current in a stepper motor.

In phase/enable mode, the M1 input pin controls the state of the H-bridges when xENBL = 0. If M1 is high, the outputs are disabled (high impedance) when xENBL = 0; this corresponds to asynchronous fast decay mode, and is usually used in stepper motor applications to command a "zero current" state. If M1 is low, then the outputs are both driven low; this corresponds to slow decay or brake mode, and is usually used when controlling the speed of a DC motor by PWMing the xENBL pin.

Table 3. H-Bridge Control Using Phase/Enable Mode

M1	xENBL	xPHASE	xOUT1	xOUT2
1	0	X	Z	Z
0	0	X	0	0
X	1	0	L	H
X	1	1	H	L

Indexer Mode

To allow a simple step and direction interface to control stepper motors, the DRV8834 contains a microstepping indexer. The indexer controls the state of the H-bridges automatically. Whenever there's a rising edge at the STEP input, the indexer moves to the next step, according to the direction set by the DIR pin.

The nENBL pin is used to disable the output stage in indexer mode. When nENBL = 1, the indexer inputs are still active and will respond to the STEP and DIR input pins; only the output stage is disabled.

The indexer logic in the DRV8834 allows a number of different stepping configurations. The M0 and M1 pins are used to configure the stepping format as shown in [Table 4](#).

Table 4. Stepping Format

M1	M0	STEP MODE
0	0	Full step (2-phase excitation)
0	1	1/2 step (1-2 phase excitation)
0	Z	1/4 step (W1-2 phase excitation)
1	0	8 microsteps/step
1	1	16 microsteps/step
1	Z	32 microsteps/step

Note that the M0 pin is a tri-level input. It can be driven logic low, logic high, or high-impedance (Z).

The M0 and M1 pins can be statically configured by connecting to VINT, GND, or left open, or can be driven with standard tri-state microcontroller I/O port pins. Their state is latched at each rising edge of the STEP input.

The step mode may be changed on-the-fly while the motor is moving. The indexer will advance to the next valid state for the new M0/M1 setting at the next rising edge of STEP.

The home state is 45°. This state is entered after power-up, after exiting undervoltage lockout, or after exiting sleep mode. This is shown in [Table 5](#) by cells shaded yellow.

The following table shows the relative current and step directions for different step mode settings. At each rising edge of the STEP input, the indexer travels to the next state in the table. The direction is shown with the DIR pin high; if the DIR pin is low the sequence is reversed. Positive current is defined as xOUT1 = positive with respect to xOUT2.

Table 5. Current and Step Directions

1/32 STEP	1/16 STEP	1/8 STEP	1/4 STEP	1/2 STEP	FULL STEP 70%	WINDING CURRENT A	WINDING CURRENT B	ELECTRICAL ANGLE
1	1	1	1	1		100%	0%	0
2						100%	5%	3
3	2					100%	10%	6
4						99%	15%	8
5	3	2				98%	20%	11
6						97%	24%	14
7	4					96%	29%	17
8						94%	34%	20
9	5	3	2			92%	38%	23
10						90%	43%	25
11	6					88%	47%	28
12						86%	51%	31
13	7	4				83%	56%	34
14						80%	60%	37
15	8					77%	63%	39
16						74%	67%	42
17	9	5	3	2	1	71%	71%	45
18						67%	74%	48
19	10					63%	77%	51
20						60%	80%	53
21	11	6				56%	83%	56
22						51%	86%	59
23	12					47%	88%	62
24						43%	90%	65
25	13	7	4			38%	92%	68
26						34%	94%	70
27	14					29%	96%	73
28						24%	97%	76
29	15	8				20%	98%	79
30						15%	99%	82
31	16					10%	100%	84
32						5%	100%	87
33	17	9	5	3		0%	100%	90
34						-5%	100%	93
35	18					-10%	100%	96
36						-15%	99%	98
37	19	10				-20%	98%	101
38						-24%	97%	104
39	20					-29%	96%	107
40						-34%	94%	110
41	21	11	6			-38%	92%	113
42						-43%	90%	115
43	22					-47%	88%	118
44						-51%	86%	121
45	23	12				-56%	83%	124
46						-60%	80%	127
47	24					-63%	77%	129

Table 5. Current and Step Directions (continued)

1/32 STEP	1/16 STEP	1/8 STEP	1/4 STEP	1/2 STEP	FULL STEP 70%	WINDING CURRENT A	WINDING CURRENT B	ELECTRICAL ANGLE
48						-67%	74%	132
49	25	13	7	4	2	-71%	71%	135
50						-74%	67%	138
51	26					-77%	63%	141
52						-80%	60%	143
53	27	14				-83%	56%	146
54						-86%	51%	149
55	28					-88%	47%	152
56						-90%	43%	155
57	29	15	8			-92%	38%	158
58						-94%	34%	160
59	30					-96%	29%	163
60						-97%	24%	166
61	31	16				-98%	20%	169
62						-99%	15%	172
63	32					-100%	10%	174
64						-100%	5%	177
65	33	17	9	5		-100%	0%	180
66						-100%	-5%	183
67	34					-100%	-10%	186
68						-99%	-15%	188
69	35	18				-98%	-20%	191
70						-97%	-24%	194
71	36					-96%	-29%	197
72						-94%	-34%	200
73	37	19	10			-92%	-38%	203
74						-90%	-43%	205
75	38					-88%	-47%	208
76						-86%	-51%	211
77	39	20				-83%	-56%	214
78						-80%	-60%	217
79	40					-77%	-63%	219
80						-74%	-67%	222
81	41	21	11	6	3	-71%	-71%	225
82						-67%	-74%	228
83	42					-63%	-77%	231
84						-60%	-80%	233
85	43	22				-56%	-83%	236
86						-51%	-86%	239
87	44					-47%	-88%	242
88						-43%	-90%	245
89	45	23	12			-38%	-92%	248
90						-34%	-94%	250
91	46					-29%	-96%	253
92						-24%	-97%	256
93	47	24				-20%	-98%	259
94						-15%	-99%	262

Table 5. Current and Step Directions (continued)

1/32 STEP	1/16 STEP	1/8 STEP	1/4 STEP	1/2 STEP	FULL STEP 70%	WINDING CURRENT A	WINDING CURRENT B	ELECTRICAL ANGLE
95	48					-10%	-100%	264
96						-5%	-100%	267
97	49	25	13	7		0%	-100%	270
98						5%	-100%	273
99	50					10%	-100%	276
100						15%	-99%	278
101	51	26				20%	-98%	281
102						24%	-97%	284
103	52					29%	-96%	287
104						34%	-94%	290
105	53	27	14			38%	-92%	293
106						43%	-90%	295
107	54					47%	-88%	298
108						51%	-86%	301
109	55	28				56%	-83%	304
110						60%	-80%	307
111	56					63%	-77%	309
112						67%	-74%	312
113	57	29	15	8	4	71%	-71%	315
114						74%	-67%	318
115	58					77%	-63%	321
116						80%	-60%	323
117	59	30				83%	-56%	326
118						86%	-51%	329
119	60					88%	-47%	332
120						90%	-43%	335
121	61	31	16			92%	-38%	338
122						94%	-34%	340
123	62					96%	-29%	343
124						97%	-24%	346
125	63	32				98%	-20%	349
126						99%	-15%	352
127	64					100%	-10%	354
128						100%	-5%	357

nSLEEP Operation

Driving nSLEEP low will put the device into a low power sleep state. In this state, the H-bridges are disabled, the gate drive charge pump is stopped, all internal logic is reset (note that this returns the indexer to the home state), the VINT supply is disabled, and all internal clocks are stopped. All inputs are ignored until nSLEEP returns inactive high.

Since the VINT supply is disabled during sleep mode, it cannot be used to provide a logic high signal to the nSLEEP pin. To simplify board design, the nSLEEP can be pulled up directly to the supply (VM) if it is not actively driven. Unless VM is less than 5.75 V, a pullup resistor is required.

The nSLEEP pin is protected by a zener diode that will clamp the pin voltage to approximately 6.5 V. The pullup resistor limits the current to the input in case VM is higher than 6.5 V. The recommended pullup resistor is 20 k Ω - 50 k Ω .

When exiting sleep mode, the nFAULT pin will be briefly driven active low as the internal power supplies turn on. nFAULT will return to inactive high once the internal power supplies (including charge pump) have stabilized. This process takes some time (up to 1 ms), before the motor driver becomes fully operational.

Protection Circuits

The DRV8834 is fully protected against undervoltage, overcurrent and overtemperature events.

Overcurrent Protection (OCP)

An analog current limit circuit on each FET limits the current through the FET by limiting the gate drive. If this analog current limit persists for longer than the OCP deglitch time (t_{OCP}), all FETs in the H-bridge will be disabled and the nFAULT pin will be driven low. The driver will be re-enabled after the OCP retry period (approximately 1.2 ms) has passed. nFAULT becomes high again at this time. If the fault condition is still present, the cycle repeats. If the fault is no longer present, normal operation resumes and nFAULT remains deasserted. Please note that only the H-bridge in which the OCP is detected will be disabled while the other bridge will function normally.

Overcurrent conditions are detected independently on both high and low side devices; i.e., a short to ground, supply, or across the motor winding will all result in an overcurrent shutdown. Note that overcurrent protection does not use the current sense circuitry used for PWM current control, so functions even without presence of the xISEN resistors.

Thermal Shutdown (TSD)

If the die temperature exceeds safe limits, all FETs in the H-bridge will be disabled and the nFAULT pin will be driven low. Once the die temperature has fallen to a safe level operation will automatically resume and nFAULT will become inactive.

Undervoltage Lockout (UVLO)

If at any time the voltage on the VM pin falls below the undervoltage lockout threshold voltage, all circuitry in the device will be disabled, and all internal logic will be reset. Operation will resume when VM rises above the UVLO threshold. The nFAULT pin is driven low during an undervoltage condition, and also at power-up or sleep mode, until the internal power supplies have stabilized.

APPLICATIONS INFORMATION

The DRV8834 is a very flexible motor driver. It can be used to drive two DC motors or a stepper motor, in a number of different configurations.

The following applications schematics show various configurations and connections for the DRV8834.

Note that component values, especially for RSENSE and the DECAy pins, may be different depending on your motor and application. Refer to the information above to determine the best values for these components in your application.

Phase/Enable Mode Driving Two DC Motors

In this configuration, the DRV8834 is used to drive two independent DC motors. Current up to 1 A per motor is possible. The M1 pin is pulled low to allow slow decay PWM from the controller (if desired) to control the motor speed by PWMing the xENBL inputs, and ADECAY and BDECAY are connected to ground to set slow decay mode during current limiting. The value of the RSENSE resistors shown is for a 1-A current limit; if current limiting is not needed, the AISEN and BISEN pins may be connected directly to ground. If the sleep function is not needed, nSLEEP can be connected to VM with an approximate 47-kΩ resistor.

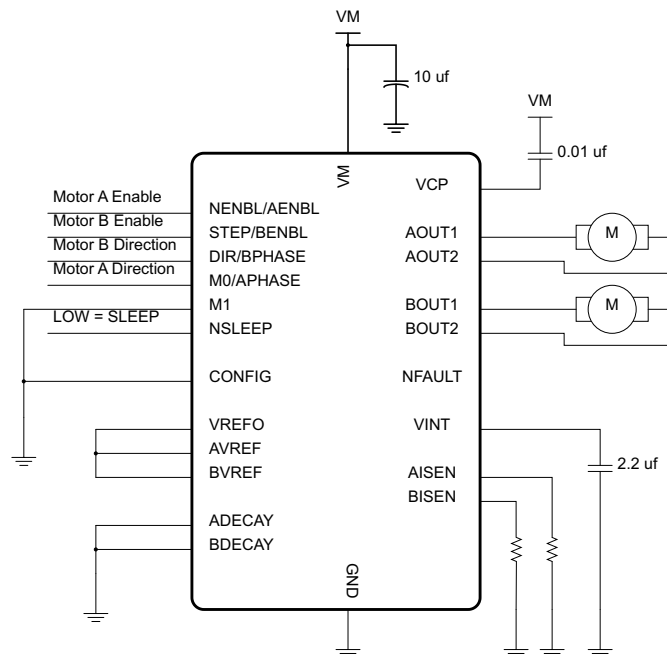

Figure 4. Phase/Enable Mode Driving Two DC Motors

Phase/Enable Mode Driving a Stepper Motor

Phase/enable mode can be used with a simple interface to a controller to operate a stepper motor in full, half, or quarter step modes. The decay mode can be set by changing the values of the resistors connected to the ADECAY and BDECAY pins. The M1 pin is driven to logic high (by connecting to the VINT supply), to allow a zero-current (off) state when the xENBL pin is set low. Coil current is set by the RSENSE resistors. If the sleep function is not needed, nSLEEP can be connected to VM with an approximate 47-kΩ resistor.

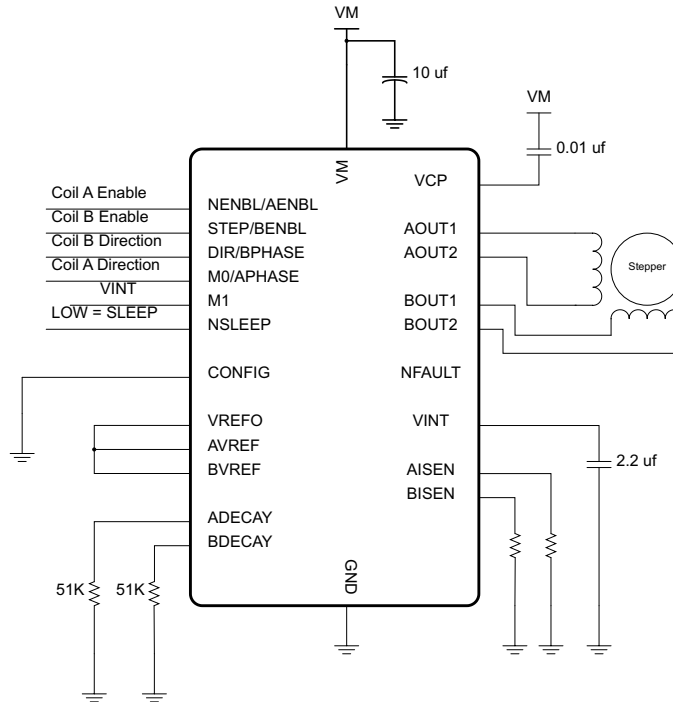

Figure 5. Phase/Enable Mode Driving a Stepper Motor

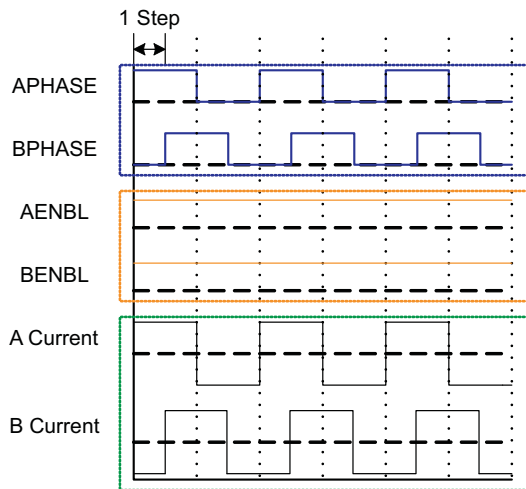

Figure 6. Full Step Sequence (2-Phase)

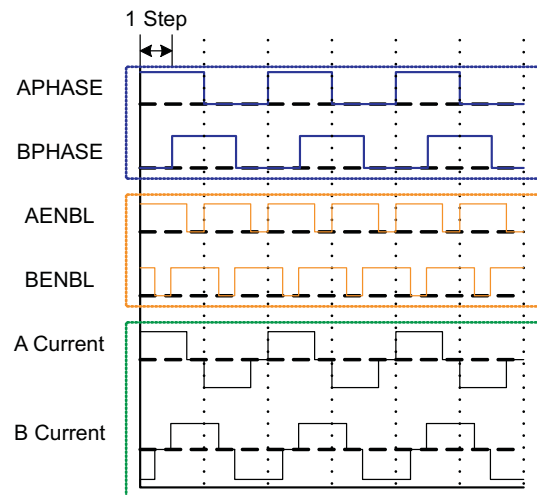

Figure 7. Half Step Sequence (1-2 Phase)

Indexer Mode Driving a Stepper Motor

In indexer mode, only a rising edge on the STEP pin is needed to move the motor to the next step. The DIR pin sets which direction the motor rotates, by reversing the step sequence. The internal indexer can operate in full-step, half-step, and smaller microsteps up to 1/32-step, depending on the state of the M0 and M1 pins. The M0 and M1 pins can also be connected directly to ground or to VINT to program the step modes, if desired. If the sleep function is not needed, nSLEEP can be connected to VM with an approximate 47-kΩ resistor. Step sequences for full and half step are shown below.

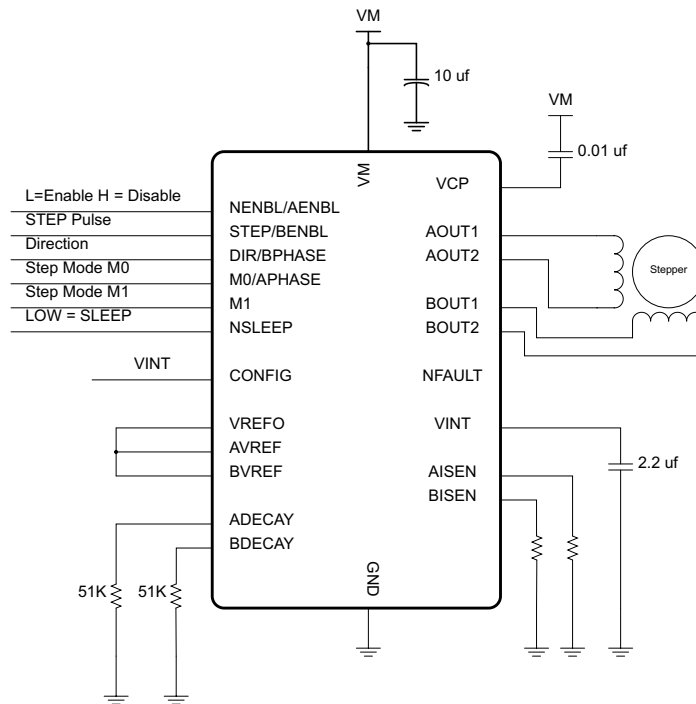

Figure 8. Indexer Mode Driving a Stepper Motor

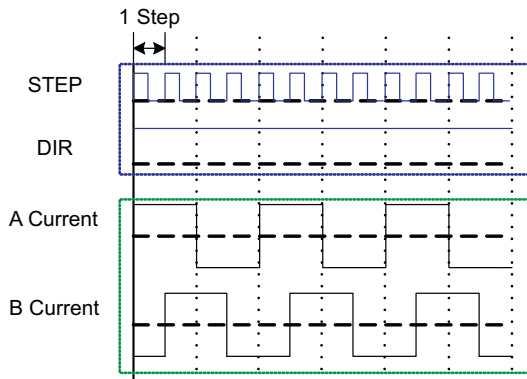

Figure 9. Full Step Sequence (2-Phase)

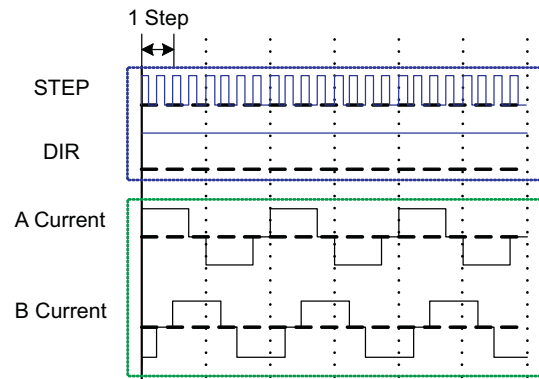

Figure 10. Half Step Sequence (1-2 Phase)

High-Resolution Microstepping Using a Microcontroller to Modulate VREF Signals

Using a microcontroller with two DAC outputs, very high resolution microstepping can be performed with the DRV8834. In this mode, the coil current direction is controlled by the PHASE pins, and the current in each coil is independently set using the two VREF input pins, which are connected to DACs. In addition, the microcontroller can set the decay mode for each coil dynamically, by driving the xDECAY pin low for slow decay, high for fast decay, or high-impedance which sets mixed decay (based on the value of a resistor connected to ground). If the sleep function is not needed, nSLEEP can be connected to VM with an approximate 47-kΩ resistor.

For more details on this technique, please refer to TI Application Report (SLVA416), "High Resolution Microstepping Driver With the DRV88xx Series".

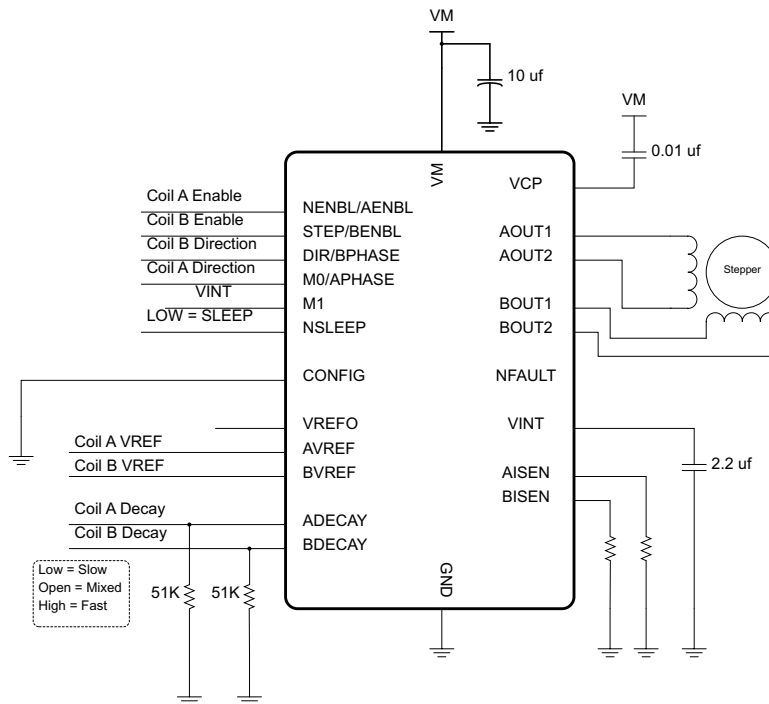

Figure 11. High-Resolution Microstepping

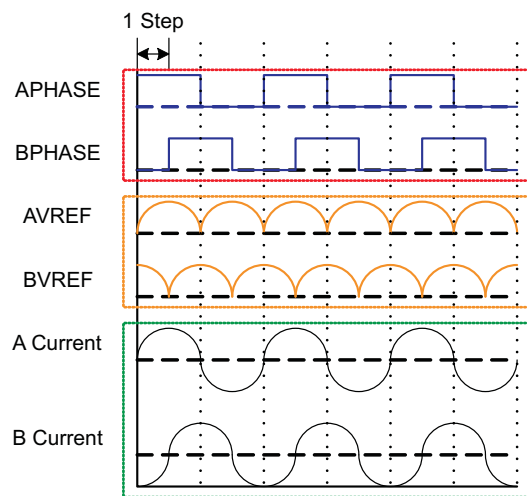

Figure 12. Microstepping Sequence

THERMAL INFORMATION

Maximum Output Current

In actual operation, the maximum output current achievable with a motor driver is a function of die temperature. This in turn is greatly affected by ambient temperature and PCB design. Basically, the maximum motor current will be the amount of current that results in a power dissipation level that, along with the thermal resistance of the package and PCB, keeps the die at a low enough temperature to stay out of thermal shutdown.

The thermal data given in the datasheet can be used as a guide to calculate the approximate maximum power dissipation that can be expected to be possible without entering thermal shutdown for several different PCB constructions. However, for accurate data, the actual PCB design must be analyzed via measurement or thermal simulation.

Thermal Protection

The DRV8834 has thermal shutdown (TSD) as described above. If the die temperature exceeds approximately 160°C, the device will be disabled until the temperature drops to a safe level.

Any tendency of the device to enter thermal shutdown is an indication of either excessive power dissipation, insufficient heatsinking, or too high an ambient temperature.

Power Dissipation

Power dissipation in the DRV8834 is dominated by the DC power dissipated in the output FET resistance, or $R_{DS(ON)}$. There is additional power dissipated due to PWM switching losses, which are dependent on PWM frequency, rise and fall times, and VM supply voltages. These switching losses are typically on the order of 10% to 20% of the DC power dissipation.

The DC power dissipation of one H-bridge can be roughly estimated by [Equation 2](#).

$$P_{TOT} = (HS - R_{DS(ON)} \cdot I_{OUT(RMS)}^2) + (LS - R_{DS(ON)} \cdot I_{OUT(RMS)}^2) \quad (2)$$

where P_{TOT} is the total power dissipation, $HS - R_{DS(ON)}$ is the resistance of the high side FET, $LS - R_{DS(ON)}$ is the resistance of the low side FET, and $I_{OUT(RMS)}$ is the RMS output current being applied to the motor.

Note that $R_{DS(ON)}$ increases with temperature, so as the device heats, the power dissipation increases. This must be taken into consideration when sizing the heatsink.

Heatsinking

The PowerPAD™ package uses an exposed pad to remove heat from the device. For proper operation, this pad must be thermally connected to copper on the PCB to dissipate heat. On a multi-layer PCB with a ground plane, this can be accomplished by adding a number of vias to connect the thermal pad to the ground plane. On PCBs without internal planes, copper area can be added on either side of the PCB to dissipate heat. If the copper area is on the opposite side of the PCB from the device, thermal vias are used to transfer the heat between top and bottom layers.

For details about how to design the PCB, refer to TI application report [SLMA002](#), "PowerPAD™ Thermally Enhanced Package" and TI application brief [SLMA004](#), "PowerPAD™ Made Easy", available at www.ti.com.

In general, the more copper area that can be provided, the more power can be dissipated.

PACKAGING INFORMATION

Orderable Device	Status (1)	Package Type	Package Drawing	Pins	Package Qty	Eco Plan (2)	Lead/Ball Finish	MSL Peak Temp (3)	Op Temp (°C)	Top-Side Markings (4)	Samples
DRV8834PWP	ACTIVE	HTSSOP	PWP	24	60	Green (RoHS & no Sb/Br)	CU NIPDAU	Level-3-260C-168 HR	-40 to 85	DRV8834	Samples
DRV8834PWPR	ACTIVE	HTSSOP	PWP	24	2000	Green (RoHS & no Sb/Br)	CU NIPDAU	Level-3-260C-168 HR	-40 to 85	DRV8834	Samples
DRV8834RGER	ACTIVE	VQFN	RGE	24	3000	Green (RoHS & no Sb/Br)	CU NIPDAU	Level-3-260C-168 HR	-40 to 85	DRV8834	Samples
DRV8834RGET	ACTIVE	VQFN	RGE	24	250	Green (RoHS & no Sb/Br)	CU NIPDAU	Level-3-260C-168 HR	-40 to 85	DRV8834	Samples

(1) The marketing status values are defined as follows:

ACTIVE: Product device recommended for new designs.

LIFEBUY: TI has announced that the device will be discontinued, and a lifetime-buy period is in effect.

NRND: Not recommended for new designs. Device is in production to support existing customers, but TI does not recommend using this part in a new design.

PREVIEW: Device has been announced but is not in production. Samples may or may not be available.

OBSOLETE: TI has discontinued the production of the device.

(2) Eco Plan - The planned eco-friendly classification: Pb-Free (RoHS), Pb-Free (RoHS Exempt), or Green (RoHS & no Sb/Br) - please check <http://www.ti.com/productcontent> for the latest availability information and additional product content details.

TBD: The Pb-Free/Green conversion plan has not been defined.

Pb-Free (RoHS): TI's terms "Lead-Free" or "Pb-Free" mean semiconductor products that are compatible with the current RoHS requirements for all 6 substances, including the requirement that lead not exceed 0.1% by weight in homogeneous materials. Where designed to be soldered at high temperatures, TI Pb-Free products are suitable for use in specified lead-free processes.

Pb-Free (RoHS Exempt): This component has a RoHS exemption for either 1) lead-based flip-chip solder bumps used between the die and package, or 2) lead-based die adhesive used between the die and leadframe. The component is otherwise considered Pb-Free (RoHS compatible) as defined above.

Green (RoHS & no Sb/Br): TI defines "Green" to mean Pb-Free (RoHS compatible), and free of Bromine (Br) and Antimony (Sb) based flame retardants (Br or Sb do not exceed 0.1% by weight in homogeneous material)

(3) MSL, Peak Temp. -- The Moisture Sensitivity Level rating according to the JEDEC industry standard classifications, and peak solder temperature.

(4) Only one of markings shown within the brackets will appear on the physical device.

Important Information and Disclaimer: The information provided on this page represents TI's knowledge and belief as of the date that it is provided. TI bases its knowledge and belief on information provided by third parties, and makes no representation or warranty as to the accuracy of such information. Efforts are underway to better integrate information from third parties. TI has taken and continues to take reasonable steps to provide representative and accurate information but may not have conducted destructive testing or chemical analysis on incoming materials and chemicals. TI and TI suppliers consider certain information to be proprietary, and thus CAS numbers and other limited information may not be available for release.

In no event shall TI's liability arising out of such information exceed the total purchase price of the TI part(s) at issue in this document sold by TI to Customer on an annual basis.

TAPE AND REEL INFORMATION

QUADRANT ASSIGNMENTS FOR PIN 1 ORIENTATION IN TAPE

*All dimensions are nominal

Device	Package Type	Package Drawing	Pins	SPQ	Reel Diameter (mm)	Reel Width W1 (mm)	A0 (mm)	B0 (mm)	K0 (mm)	P1 (mm)	W (mm)	Pin1 Quadrant
DRV8834PWPR	HTSSOP	PWP	24	2000	330.0	16.4	6.95	8.3	1.6	8.0	16.0	Q1
DRV8834RGER	VQFN	RGE	24	3000	330.0	12.4	4.25	4.25	1.15	8.0	12.0	Q2
DRV8834RGET	VQFN	RGE	24	250	180.0	12.4	4.25	4.25	1.15	8.0	12.0	Q2

TAPE AND REEL BOX DIMENSIONS



*All dimensions are nominal

Device	Package Type	Package Drawing	Pins	SPQ	Length (mm)	Width (mm)	Height (mm)
DRV8834PWPR	HTSSOP	PWP	24	2000	367.0	367.0	38.0
DRV8834RGER	VQFN	RGE	24	3000	367.0	367.0	35.0
DRV8834RGET	VQFN	RGE	24	250	210.0	185.0	35.0

MECHANICAL DATA

PWP (R-PDSO-G24)

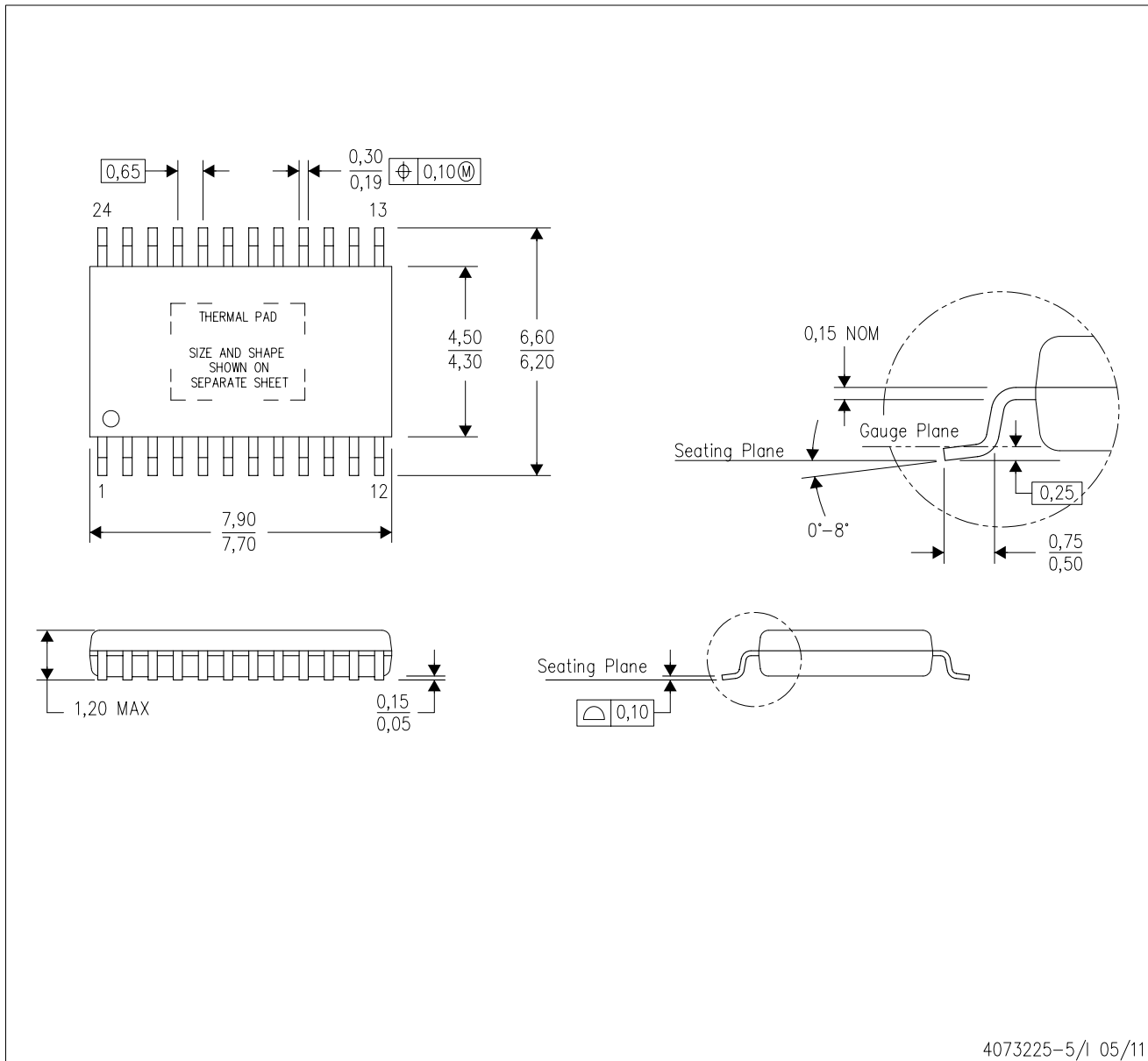
PowerPAD™ PLASTIC SMALL OUTLINE



4073225-5/1 05/11

- NOTES:
- All linear dimensions are in millimeters.
 - This drawing is subject to change without notice.
 - Body dimensions do not include mold flash or protrusions. Mold flash and protrusion shall not exceed 0.15 per side.
 - This package is designed to be soldered to a thermal pad on the board. Refer to Technical Brief, PowerPad Thermally Enhanced Package, Texas Instruments Literature No. SLMA002 for information regarding recommended board layout. This document is available at www.ti.com <<http://www.ti.com>>.
 - See the additional figure in the Product Data Sheet for details regarding the exposed thermal pad features and dimensions.
 - Falls within JEDEC MO-153

PowerPAD is a trademark of Texas Instruments.

THERMAL PAD MECHANICAL DATA

PWP (R-PDSO-G24) PowerPAD™ SMALL PLASTIC OUTLINE

THERMAL INFORMATION

This PowerPAD™ package incorporates an exposed thermal pad that is designed to be attached to a printed circuit board (PCB). The thermal pad must be soldered directly to the PCB. After soldering, the PCB can be used as a heatsink. In addition, through the use of thermal vias, the thermal pad can be attached directly to the appropriate copper plane shown in the electrical schematic for the device, or alternatively, can be attached to a special heatsink structure designed into the PCB. This design optimizes the heat transfer from the integrated circuit (IC).

For additional information on the PowerPAD package and how to take advantage of its heat dissipating abilities, refer to Technical Brief, PowerPAD Thermally Enhanced Package, Texas Instruments Literature No. SLMA002 and Application Brief, PowerPAD Made Easy, Texas Instruments Literature No. SLMA004. Both documents are available at www.ti.com.

The exposed thermal pad dimensions for this package are shown in the following illustration.

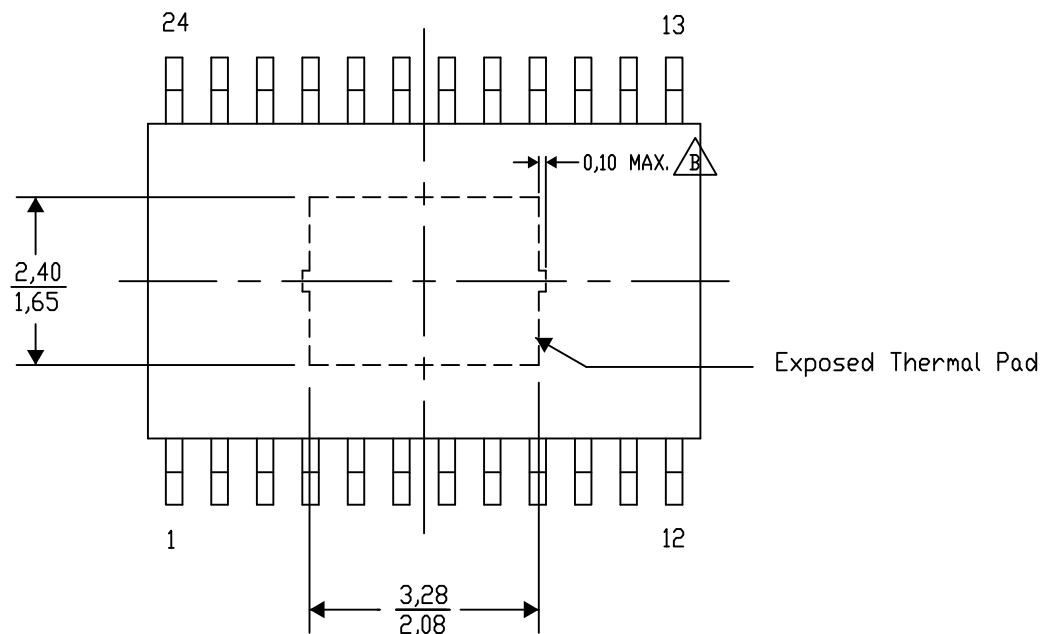

Top View

Exposed Thermal Pad Dimensions

4206332-31/AC 07/12

NOTE: A. All linear dimensions are in millimeters

 B. Exposed tie strap features may not be present.

PowerPAD is a trademark of Texas Instruments

PWP (R-PDSO-G24)

PowerPAD™ PLASTIC SMALL OUTLINE

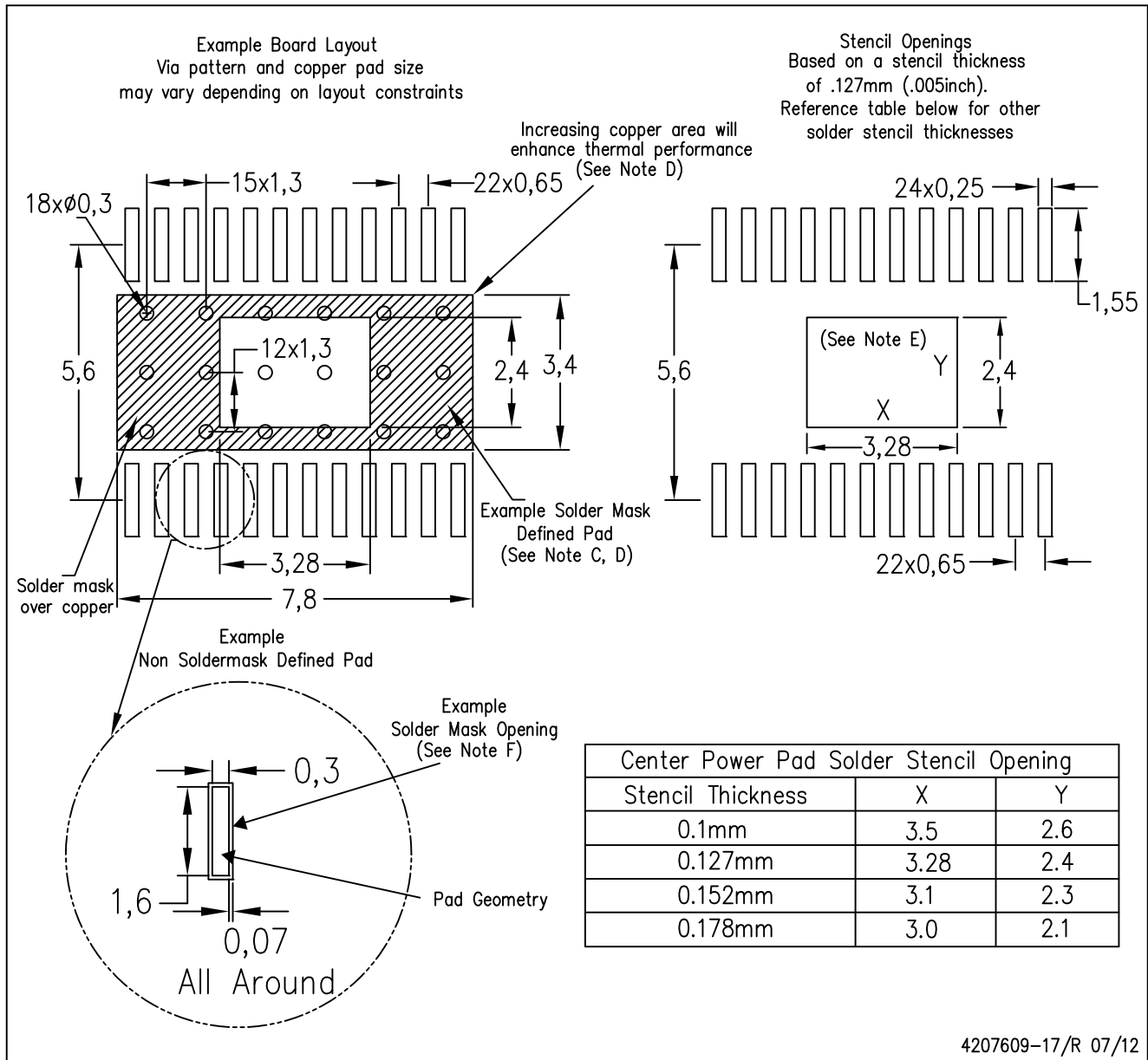

- NOTES:
- A. All linear dimensions are in millimeters.
 - B. This drawing is subject to change without notice.
 - C. Customers should place a note on the circuit board fabrication drawing not to alter the center solder mask defined pad.
 - D. This package is designed to be soldered to a thermal pad on the board. Refer to Technical Brief, PowerPAD Thermally Enhanced Package, Texas Instruments Literature No. SLMA002, SLMA004, and also the Product Data Sheets for specific thermal information, via requirements, and recommended board layout. These documents are available at www.ti.com <<http://www.ti.com>>. Publication IPC-7351 is recommended for alternate designs.
 - E. Laser cutting apertures with trapezoidal walls and also rounding corners will offer better paste release. Customers should contact their board assembly site for stencil design recommendations. Example stencil design based on a 50% volumetric metal load solder paste. Refer to IPC-7525 for other stencil recommendations.
 - F. Customers should contact their board fabrication site for solder mask tolerances between and around signal pads.

RGE (S-PVQFN-N24)

PLASTIC QUAD FLATPACK NO-LEAD

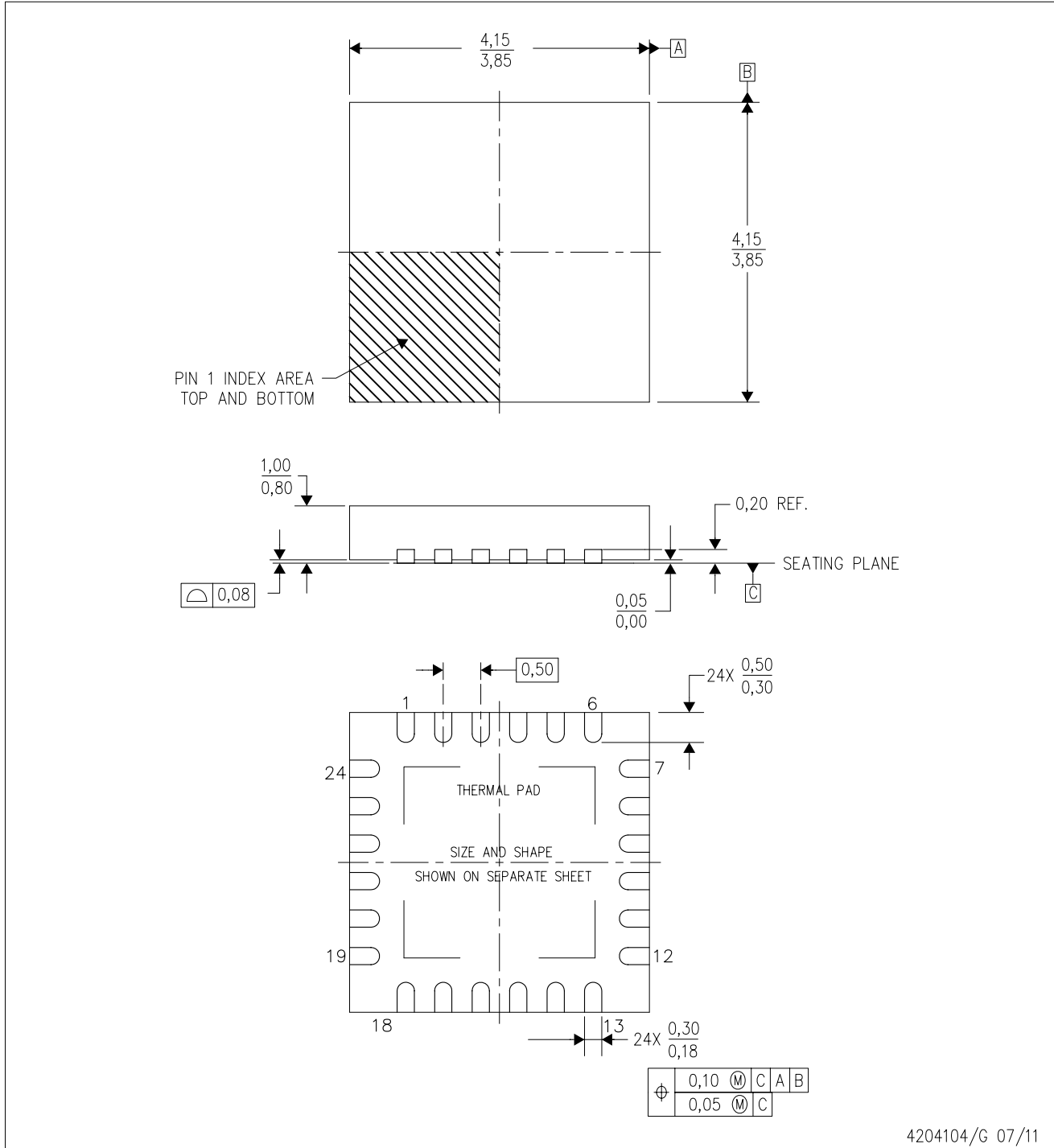

4204104/G 07/11

- NOTES:
- All linear dimensions are in millimeters. Dimensioning and tolerancing per ASME Y14.5M-1994.
 - This drawing is subject to change without notice.
 - Quad Flatpack, No-Leads (QFN) package configuration.
 - The package thermal pad must be soldered to the board for thermal and mechanical performance.
 - See the additional figure in the Product Data Sheet for details regarding the exposed thermal pad features and dimensions.
 - Falls within JEDEC MO-220.

THERMAL PAD MECHANICAL DATA

RGE (S-PVQFN-N24)

PLASTIC QUAD FLATPACK NO-LEAD

THERMAL INFORMATION

This package incorporates an exposed thermal pad that is designed to be attached directly to an external heatsink. The thermal pad must be soldered directly to the printed circuit board (PCB). After soldering, the PCB can be used as a heatsink. In addition, through the use of thermal vias, the thermal pad can be attached directly to the appropriate copper plane shown in the electrical schematic for the device, or alternatively, can be attached to a special heatsink structure designed into the PCB. This design optimizes the heat transfer from the integrated circuit (IC).

For information on the Quad Flatpack No-Lead (QFN) package and its advantages, refer to Application Report, QFN/SON PCB Attachment, Texas Instruments Literature No. SLUA271. This document is available at www.ti.com.

The exposed thermal pad dimensions for this package are shown in the following illustration.

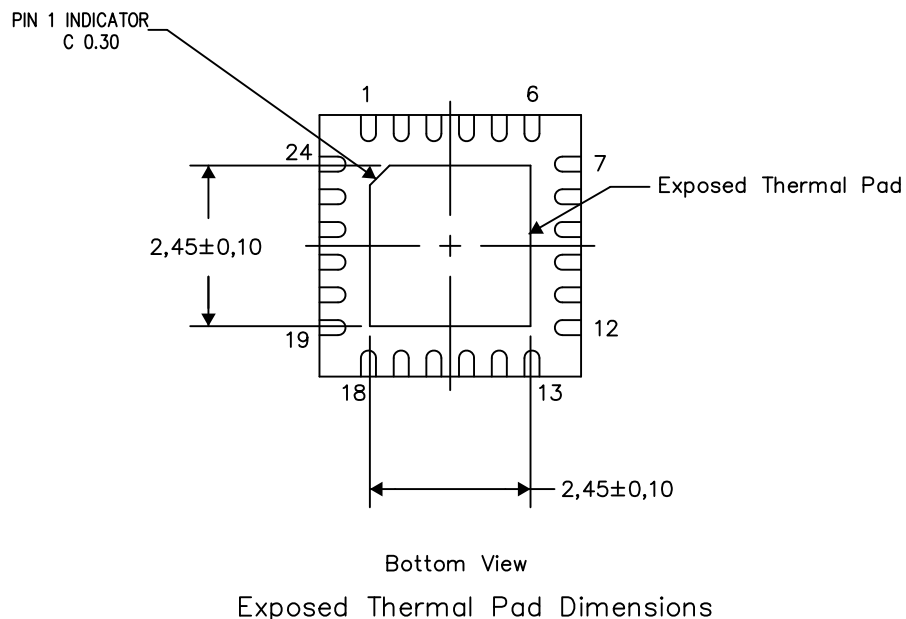

4206344-3/AB 09/12

NOTES: A. All linear dimensions are in millimeters

RGE (S-PVQFN-N24)

PLASTIC QUAD FLATPACK NO-LEAD

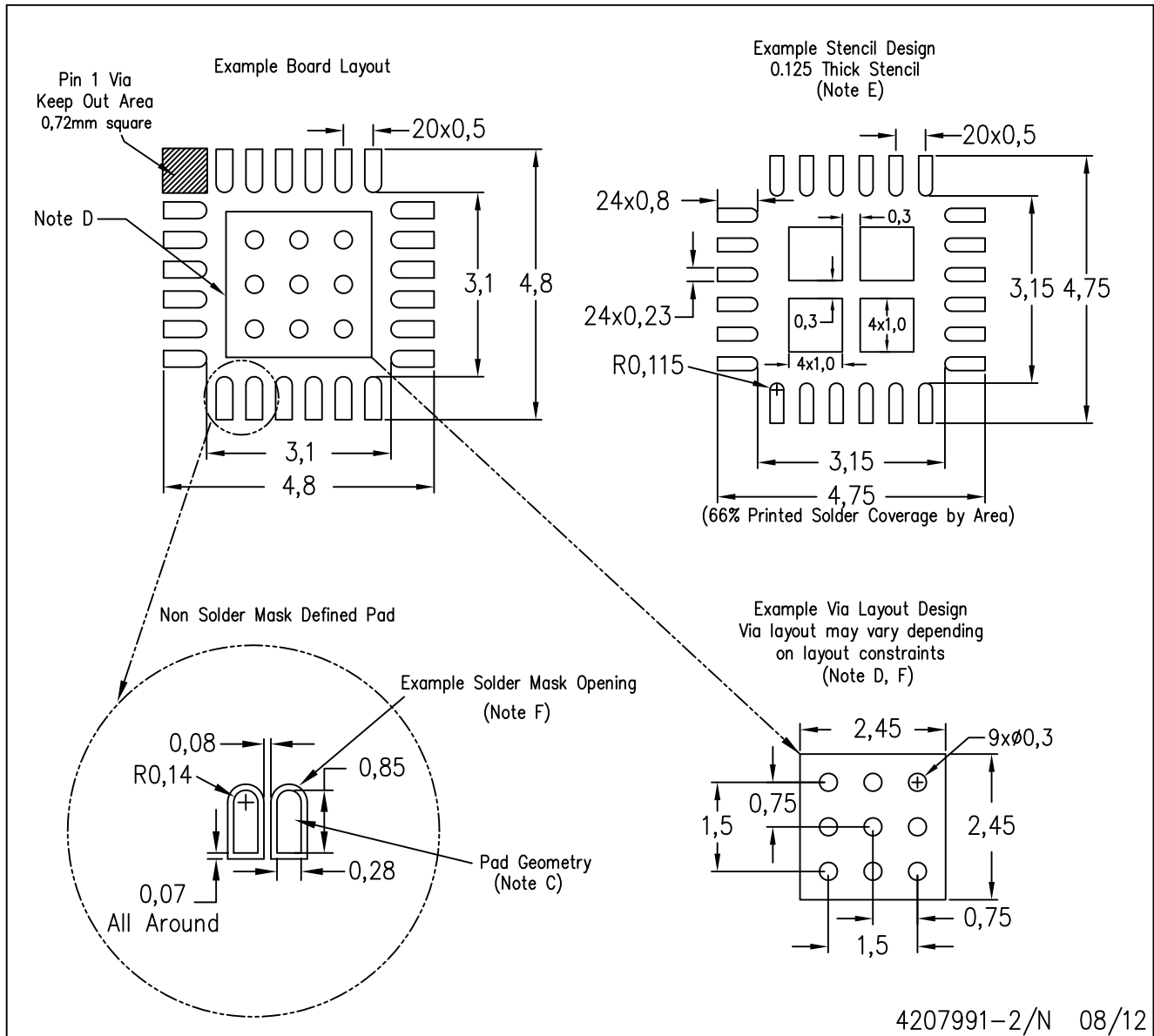

- NOTES:
- All linear dimensions are in millimeters.
 - This drawing is subject to change without notice.
 - Publication IPC-7351 is recommended for alternate designs.
 - This package is designed to be soldered to a thermal pad on the board. Refer to Application Note, Quad Flat-Pack Packages, Texas Instruments Literature No. SLUA271, and also the Product Data Sheets for specific thermal information, via requirements, and recommended board layout. These documents are available at www.ti.com <<http://www.ti.com>>.
 - Laser cutting apertures with trapezoidal walls and also rounding corners will offer better paste release. Customers should contact their board assembly site for stencil design recommendations. Refer to IPC 7525 for stencil design considerations.
 - Customers should contact their board fabrication site for recommended solder mask tolerances and via tenting recommendations for vias placed in the thermal pad.

重要声明

德州仪器(TI) 及其下属子公司有权根据 JESD46 最新标准, 对所提供的产品和服务进行更正、修改、增强、改进或其它更改, 并有权根据 JESD48 最新标准中止提供任何产品和服务。客户在下订单前应获取最新的相关信息, 并验证这些信息是否完整且是最新的。所有产品的销售都遵循在订单确认时所提供的TI 销售条款与条件。

TI 保证其所销售的组件的性能符合产品销售时 TI 半导体产品销售条件与条款的适用规范。仅在 TI 保证的范围内, 且 TI 认为有必要时才会使用测试或其它质量控制技术。除非适用法律做出了硬性规定, 否则没有必要对每种组件的所有参数进行测试。

TI 对应用帮助或客户产品设计不承担任何义务。客户应对其使用 TI 组件的产品和应用自行负责。为尽量减小与客户产品和应用相关的风险, 客户应提供充分的设计与操作安全措施。

TI 不对任何 TI 专利权、版权、屏蔽作品权或其它与使用了 TI 组件或服务的组合设备、机器或流程相关的 TI 知识产权中授予的直接或隐含权作出任何保证或解释。TI 所发布的与第三方产品或服务有关的信息, 不能构成从 TI 获得使用这些产品或服务的许可、授权、或认可。使用此类信息可能需要获得第三方的专利权或其它知识产权方面的许可, 或是 TI 的专利权或其它知识产权方面的许可。

对于 TI 的产品手册或数据表中 TI 信息的重要部分, 仅在没有对内容进行任何篡改且带有相关授权、条件、限制和声明的情况下才允许进行复制。TI 对此类篡改过的文件不承担任何责任或义务。复制第三方的信息可能需要服从额外的限制条件。

在转售 TI 组件或服务时, 如果对该组件或服务参数的陈述与 TI 标明的参数相比存在差异或虚假成分, 则会失去相关 TI 组件或服务的所有明示或暗示授权, 且这是不正当的、欺诈性商业行为。TI 对任何此类虚假陈述均不承担任何责任或义务。

客户认可并同意, 尽管任何应用相关信息或支持仍可能由 TI 提供, 但他们将独力负责满足与其产品及其应用中使用的 TI 产品相关的所有法律、法规和安全相关要求。客户声明并同意, 他们具备制定与实施安全措施所需的全部专业技术和知识, 可预见故障的危险后果、监测故障及其后果、降低有可能造成人身伤害的故障的发生机率并采取适当的补救措施。客户将全额赔偿因在此类安全关键应用中使用任何 TI 组件而对 TI 及其代理造成的任何损失。

在某些场合中, 为了推进安全相关应用有可能对 TI 组件进行特别的促销。TI 的目标是利用此类组件帮助客户设计和创立其特有的可满足适用的功能安全性标准和要求的终端产品解决方案。尽管如此, 此类组件仍然服从这些条款。

TI 组件未获得用于 FDA Class III (或类似的生命攸关医疗设备) 的授权许可, 除非各方授权官员已经达成了专门管控此类使用的特别协议。

只有那些 TI 特别注明属于军用等级或“增强型塑料”的 TI 组件才是设计或专门用于军事/航空应用或环境的。购买者认可并同意, 对并非指定面向军事或航空航天用途的 TI 组件进行军事或航空航天方面的应用, 其风险由客户单独承担, 并且由客户独力负责满足与此类使用相关的所有法律和法规要求。

TI 已明确指定符合 ISO/TS16949 要求的产品, 这些产品主要用于汽车。在任何情况下, 因使用非指定产品而无法达到 ISO/TS16949 要求, TI 不承担任何责任。

	产品		应用
数字音频	www.ti.com.cn/audio	通信与电信	www.ti.com.cn/telecom
放大器和线性器件	www.ti.com.cn/amplifiers	计算机及周边	www.ti.com.cn/computer
数据转换器	www.ti.com.cn/dataconverters	消费电子	www.ti.com.cn/consumer-apps
DLP® 产品	www.dlp.com	能源	www.ti.com.cn/energy
DSP - 数字信号处理器	www.ti.com.cn/dsp	工业应用	www.ti.com.cn/industrial
时钟和计时器	www.ti.com.cn/clockandtimers	医疗电子	www.ti.com.cn/medical
接口	www.ti.com.cn/interface	安防应用	www.ti.com.cn/security
逻辑	www.ti.com.cn/logic	汽车电子	www.ti.com.cn/automotive
电源管理	www.ti.com.cn/power	视频和影像	www.ti.com.cn/video
微控制器 (MCU)	www.ti.com.cn/microcontrollers		
RFID 系统	www.ti.com.cn/rfidsys		
OMAP应用处理器	www.ti.com.cn/omap		
无线连通性	www.ti.com.cn/wirelessconnectivity	德州仪器在线技术支持社区	www.deyisupport.com

邮寄地址: 上海市浦东新区世纪大道 1568 号, 中建大厦 32 楼 邮政编码: 200122
Copyright © 2013 德州仪器 半导体技术 (上海) 有限公司