

# Haptic Driver for DC Motors (ERMs) and Linear Vibrators (LRAs) with Ultra-Fast Turn-On

 Check for Samples: [DRV8601](#)

## FEATURES

- **High Current Output: 400 mA**
- **Wide Supply Voltage (2.5 V to 5.5 V) for Direct Battery Operation**
- **Low Quiescent Current: 1.7 mA Typical**
- **Fast Startup Time: 100  $\mu$ s**
- **Low Shutdown Current: 10 nA**
- **Output Short-Circuit Protection**
- **Thermal Protection**
- **Enable Pin is 1.8 V Compatible**
- **Available Package Options**
  - 2 mm x 2 mm MicroStar Junior™ BGA Package (ZQV)
  - 3 mm x 3 mm QFN Package (DRB)

## APPLICATIONS

- **Mobile Phones**
- **Tablets**
- **Portable Gaming Consoles**
- **Portable Navigation Devices**
- **Appliance Consoles**

## DESCRIPTION

The DRV8601 is a single-supply haptic driver that is optimized to drive a DC motor (also known as Eccentric Rotating Mass or ERM in haptics terminology) or a linear vibrator (also known as Linear Resonant Actuator or LRA in haptics terminology) using a single-ended PWM input signal. With a fast turn-on time of 100  $\mu$ s, the DRV8601 is an excellent haptic driver for use in mobile phones and other portable electronic devices.

The DRV8601 drives up to 400 mA from a 3.3 V supply. Near rail-to-rail output swing under load ensures sufficient voltage drive for most DC motors. Differential output drive allows the polarity of the voltage across the output to be reversed quickly, thereby enabling motor speed control in both clockwise and counter-clockwise directions, allowing quick motor stopping. A wide input voltage range allows precise speed control of both DC motors and linear vibrators.

With a typical quiescent current of 1.7 mA and a shutdown current of 10 nA, the DRV8601 is ideal for portable applications. The DRV8601 has thermal and output short-circuit protection to prevent the device from being damaged during fault conditions.

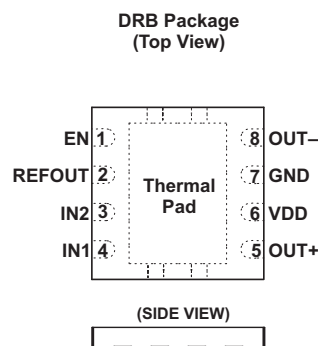
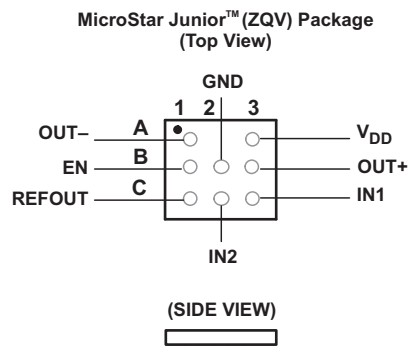

Please be aware that an important notice concerning availability, standard warranty, and use in critical applications of Texas Instruments semiconductor products and disclaimers thereto appears at the end of this data sheet.

MicroStar Junior is a trademark of Texas Instruments.



These devices have limited built-in ESD protection. The leads should be shorted together or the device placed in conductive foam during storage or handling to prevent electrostatic damage to the MOS gates.

### Pin Functions

PIN			INPUT/OUTPUT/ POWER (I/O/P)	DESCRIPTION
NAME	BALL (ZQV)	PIN (DRB)		
IN1	C3	4	I	Input to driver
IN2	C2	3	I	Input to driver
OUT+	B3	5	O	Positive output
OUT-	A1	8	O	Negative output
REFOUT	C1	2	O	Reference voltage output
EN	B1	1	I	Chip enable
VDD	A3	6	P	Supply voltage
GND	B2	7	P	Ground

### ORDERING INFORMATION

	MicroStar Junior™ (ZQV)	QFN Package (DRB)
Device	DRV8601ZQVR <sup>(1)(2)</sup>	DRV8601DRB <sup>(2)</sup>
Symbolization	HSMI	8601

- (1) The ZQV packages are only available taped and reeled. The suffix R designates taped and reeled parts in quantities of 2500.
- (2) For the most current package and ordering information, see the Package Option Addendum at the end of this document or visit the TI website at [www.ti.com](http://www.ti.com)

### THERMAL INFORMATION

THERMAL METRIC <sup>(1)</sup>		DRV8601		UNITS
		ZQV (8 BALLS)	DRB (8 PINS)	
$\theta_{JA}$	Junction-to-ambient thermal resistance	78	52.8	°C/W
$\theta_{JCTop}$	Junction-to-case (top) thermal resistance	155	63	
$\theta_{JB}$	Junction-to-board thermal resistance	65	28.4	
$\Psi_{JT}$	Junction-to-top characterization parameter	5	2.7	
$\Psi_{JB}$	Junction-to-board characterization parameter	50	28.6	
$\theta_{JCbott}$	Junction-to-case (bottom) thermal resistance	n/a	11.4	

- (1) For more information about traditional and new thermal metrics, see the *IC Package Thermal Metrics* application report, [SPRA953](http://www.ti.com/lit/zip/Spra953).

## ABSOLUTE MAXIMUM RATINGS

over operating free-air temperature range,  $T_A \leq 25^\circ\text{C}$  unless otherwise noted<sup>(1)</sup>

		VALUE / UNIT
V <sub>DD</sub>	Supply voltage	–0.3 V to 6 V
V <sub>I</sub>	Input voltage   INx, EN	–0.3 V to V <sub>DD</sub> + 0.3 V
	Output continuous total power dissipation	See Thermal Information Table
T <sub>A</sub>	Operating free-air temperature range	–40°C to 85°C
T <sub>J</sub>	Operating junction temperature range	–40°C to 150°C
T <sub>stg</sub>	Storage temperature	–65°C to 150°C

(1) Stresses beyond those listed under *absolute maximum ratings* may cause permanent damage to the device. These are stress ratings only, and functional operation of the device at these or any other conditions beyond those indicated under *recommended operating conditions* is not implied. Exposure to absolute-maximum-rated conditions for extended periods may affect device reliability.

## RECOMMENDED OPERATING CONDITIONS

		MIN	TYP	MAX	UNIT
V <sub>DD</sub>	Supply voltage	2.5		5.5	V
V <sub>IH</sub>	High-level input voltage   EN	1.15			V
V <sub>IL</sub>	Low-level input voltage   EN			0.5	V
T <sub>A</sub>	Operating free-air temperature	–40		85	°C
Z <sub>L</sub>	Load impedance	6.4			Ω

## ELECTRICAL CHARACTERISTICS

T<sub>A</sub> = 25°C, Gain = 2 V/V, R<sub>L</sub> = 10 Ω (unless otherwise noted)

PARAMETER	TEST CONDITIONS	MIN	TYP	MAX	UNIT
V <sub>OO</sub>	Output offset voltage (measured differentially) V <sub>I</sub> = 0 V, V <sub>DD</sub> = 2.5 V to 5.5 V			9	mV
V <sub>OD,N</sub>	Negative differential output voltage (V <sub>OUT+</sub> –V <sub>OUT-</sub> ) V <sub>IN+</sub> = V <sub>DD</sub> , V <sub>IN-</sub> = 0 V or V <sub>IN+</sub> = 0 V, V <sub>IN-</sub> = V <sub>DD</sub>				V
				–4.55	
				–2.87	
				–2.15	
V <sub>OD,P</sub>	Positive differential output voltage (V <sub>OUT+</sub> –V <sub>OUT-</sub> ) V <sub>IN+</sub> = V <sub>DD</sub> , V <sub>IN-</sub> = 0 V or V <sub>IN+</sub> = 0 V, V <sub>IN-</sub> = V <sub>DD</sub>				V
				4.55	
				2.87	
				2.15	
I <sub>IH</sub>	High-level EN input current V <sub>DD</sub> = 5.5 V, V <sub>I</sub> = 5.8 V			1.2	μA
I <sub>IL</sub>	Low-level EN input current V <sub>DD</sub> = 5.5 V, V <sub>I</sub> = –0.3 V			1.2	μA
I <sub>DD(Q)</sub>	Supply current V <sub>DD</sub> = 2.5 V to 5.5 V, No load, EN = V <sub>IH</sub>		1.7	2	mA
I <sub>DD(SD)</sub>	Supply current in shutdown mode EN = V <sub>IL</sub> , V <sub>DD</sub> = 2.5 V to 5.5 V, No load		0.01	0.9	μA

## OPERATING CHARACTERISTICS

T<sub>A</sub> = 25°C, Gain = 2 V/V, R<sub>L</sub> = 10 Ω (unless otherwise noted)

PARAMETER	TEST CONDITIONS	MIN	TYP	MAX	UNIT
Z <sub>I</sub>	Input impedance		2		MΩ
Z <sub>O</sub>	Output impedance Shutdown mode (EN = V <sub>IL</sub> )	>10			kΩ

## TYPICAL CHARACTERISTICS

Pseudo-Differential Feedback with Internal Reference, ZQV Package,  $V_{DD} = 3.3\text{ V}$ ,  $R_I = 100\text{ k}\Omega$ ,  $R_F = 100\text{ k}\Omega$ ,  $C_R = 0.001\text{ }\mu\text{F}$ ,  $C_F = \text{None}$ ,  $T_A = 25^\circ\text{C}$ , unless otherwise specified.

### Table of Graphs

		FIGURE
Output voltage (High)	vs Load current	1
Output voltage (Low)	vs Load current	2
Output voltage	vs Input voltage, $R_L = 10\text{ }\Omega$	3
Output voltage	vs Input voltage, $R_L = 20\text{ }\Omega$	4
Supply current	vs Supply voltage	5
Shutdown supply current	vs Supply voltage	6
Power dissipation	vs Supply voltage	7
Slew rate	vs Supply voltage	8
Output transition	vs Time	9, 10
Startup	vs Time	11
Shutdown	vs Time	12

**OUTPUT VOLTAGE (HIGH) vs LOAD CURRENT**

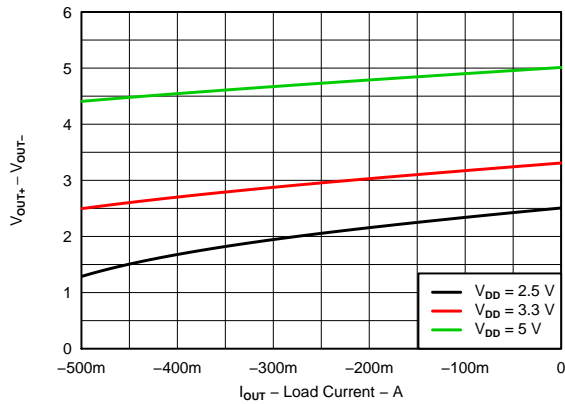

Figure 1.

**OUTPUT VOLTAGE (LOW) vs LOAD CURRENT**

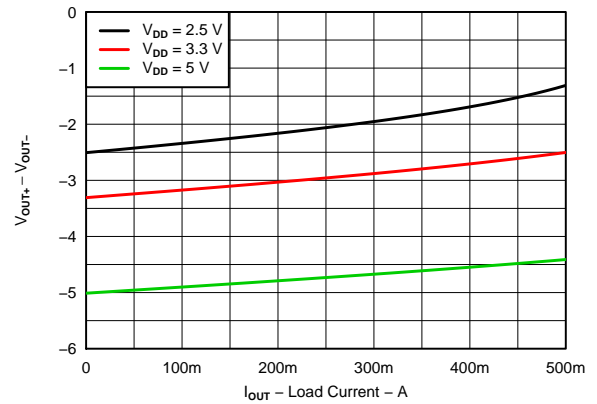

Figure 2.

**OUTPUT VOLTAGE vs INPUT VOLTAGE**

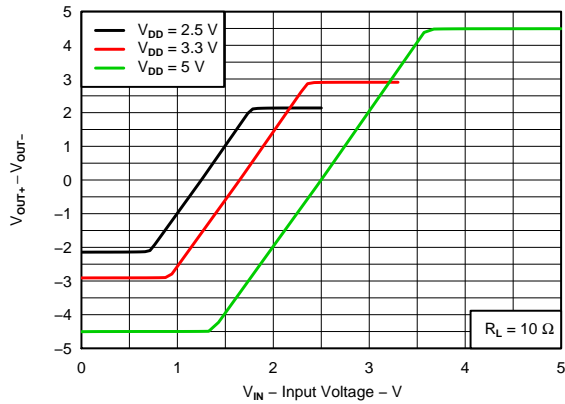

Figure 3.

**OUTPUT VOLTAGE vs INPUT VOLTAGE**

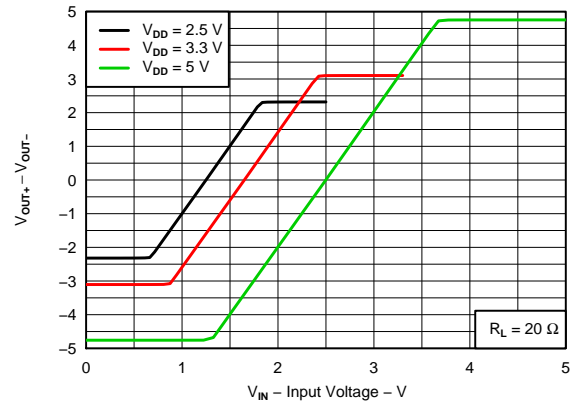

Figure 4.

**SUPPLY CURRENT vs SUPPLY VOLTAGE**

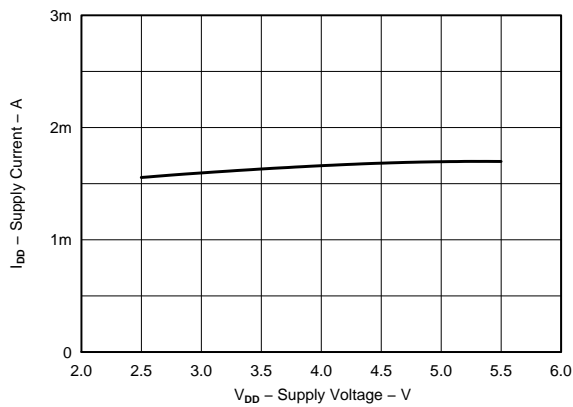

Figure 5.

**SHUTDOWN SUPPLY CURRENT vs SUPPLY VOLTAGE**

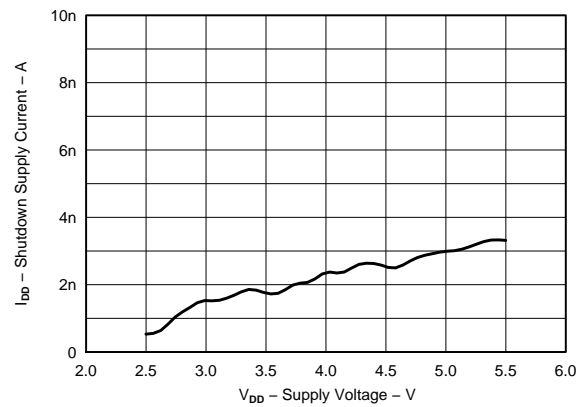

Figure 6.

**POWER DISSIPATION vs SUPPLY VOLTAGE**

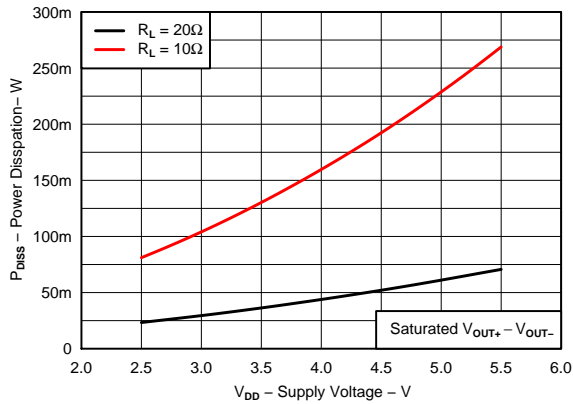

Figure 7.

**SLEW RATE vs SUPPLY VOLTAGE**

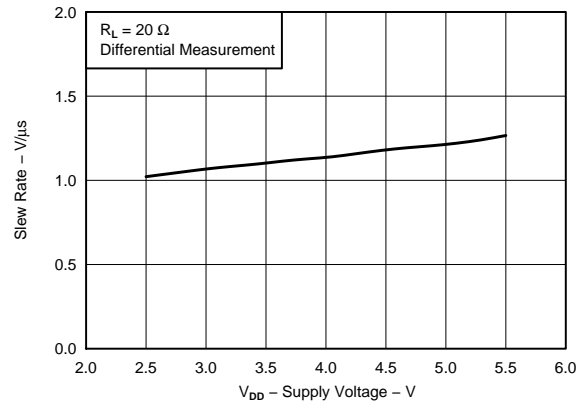

Figure 8.

**OUTPUT TRANSITION vs TIME**

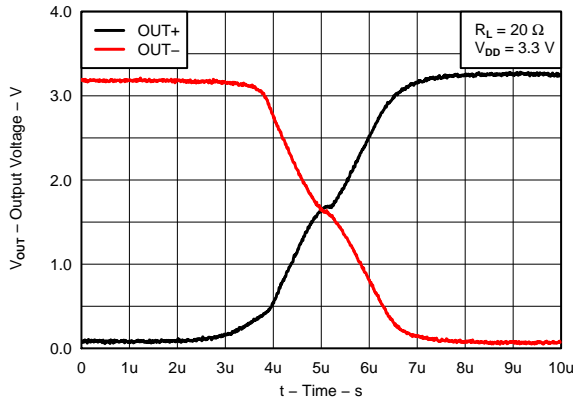

Figure 9.

**OUTPUT TRANSITION vs TIME**

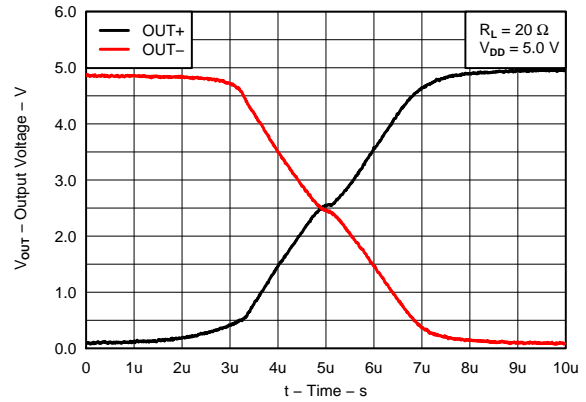

Figure 10.

**STARTUP vs TIME**

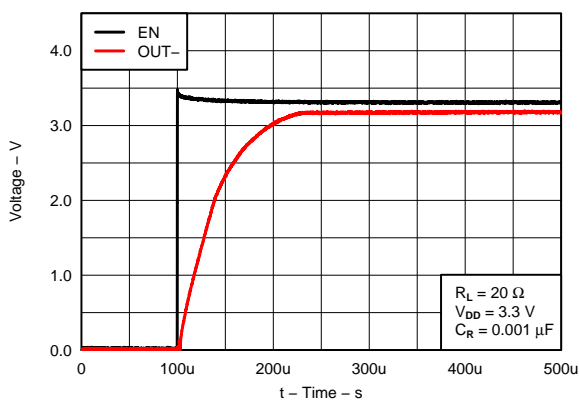

Figure 11.

**SHUTDOWN vs TIME**

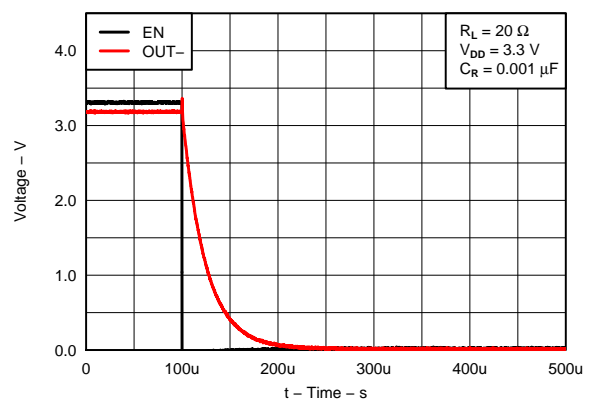

Figure 12.

## APPLICATION INFORMATION

### DRIVING DC MOTORS USING THE DRV8601

The DRV8601 is designed to drive a DC motor (also known as Eccentric Rotating Mass or ERM in haptics terminology) in both clockwise and counter-clockwise directions, as well as to stop the motor quickly. This is made possible because the outputs are fully differential and capable of sourcing and sinking current. This feature helps eliminate long vibration tails which are undesirable in haptic feedback systems.

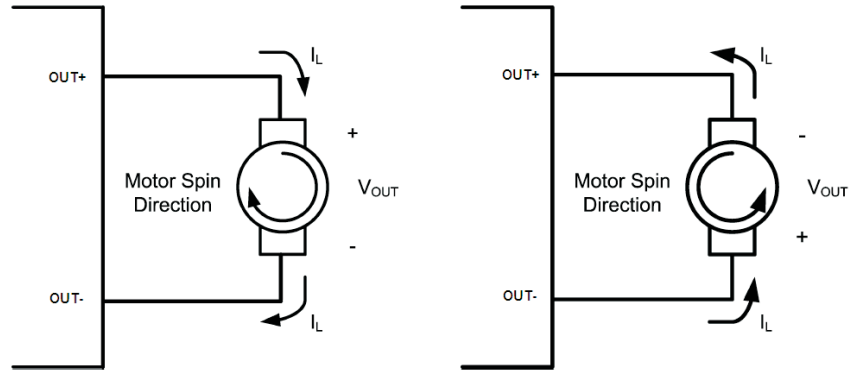

Figure 13. Reversal of Direction of Motor Spin Using DRV8601

Another common approach to driving DC motors is the concept of overdrive voltage. To overcome the inertia of the motor's mass, they are often *overdriven* for a short amount of time before returning to the motor's rated voltage to sustain the motor's rotation. The DRV8601 can overdrive a motor up to the VDD voltage. Overdrive is also used to stop (or brake) a motor quickly. The DRV8601 can brake up to a voltage of -VDD. Please reference the motor's datasheet for safe and reliable overdrive voltage and duration.

The DRV8601 can accept a single-ended PWM source or single-ended DC control voltage and perform single-ended to differential conversion. A PWM signal is typically generated using software, and many different advanced haptic sensations can be produced by inputting different types of PWM signals into the DRV8601.

### DRIVING LINEAR VIBRATORS USING THE DRV8601

Linear vibrators (also known as Linear Resonant Actuators or LRA in haptics terminology) vibrate only at their resonant frequency. Usually, linear vibrators have a high-Q frequency response due to which there is a rapid drop in vibration performance at offsets of 3-5 Hz from the resonant frequency. Therefore, while driving a linear vibrator with the DRV8601, ensure that the commutation of the input PWM signal is within the prescribed frequency range for the chosen linear vibrator. Vary the duty cycle of the PWM signal symmetrically above and below 50% to vary the strength of the vibration. As in the case of DC motors, the PWM signal is typically generated using software, and many different advanced haptic sensations can be produced by applying different PWM signals into the DRV8601.

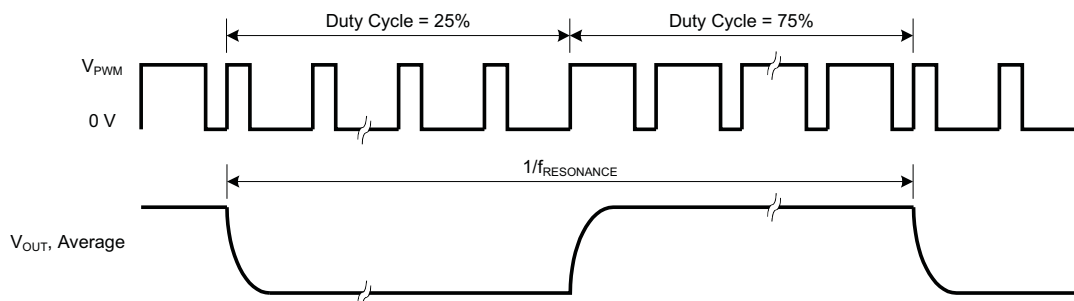

Figure 14. LRA Example for 1/2 Full-Scale Drive

## PSEUDO-DIFFERENTIAL FEEDBACK WITH INTERNAL REFERENCE

In the pseudo-differential feedback configuration (Figure 15), feedback is taken from only one of the output pins, thereby reducing the number of external components required for the solution. The DRV8601 has an internal reference voltage generator which keeps the REFOUT voltage at VDD/2. The internal reference voltage can be used if and only if the PWM voltage is the same as the supply voltage of the DRV8601 (i.e., if  $V_{PWM} = VDD$ , as assumed in this section).

Having  $V_{PWM} = VDD$  ensures that there is no voltage signal applied to the motor at a PWM duty cycle of 50%. This is a convenient way of temporarily stopping the motor without powering off the DRV8601. Also, this configuration ensures that the direction of rotation of the motor changes when crossing a PWM duty cycle of 50% in both directions. For example, if an ERM motor rotates in the clockwise direction at 20% duty cycle, it will rotate in the counter-clockwise direction at 80% duty cycle at nearly the same speed.

Mathematically, the output voltage is given by Equation 1 (where  $s$  is the Laplace Transform variable and  $V_{IN}$  is the single-ended input voltage):

$$V_{O,DIFF} = 2 \times \left( V_{IN} - \frac{V_{DD}}{2} \right) \times \frac{R_F}{R_I} \times \frac{1}{1 + sR_F C_F} \tag{1}$$

$R_F$  is normally set equal to  $R_I$  ( $R_F = R_I$ ) so that an overdrive voltage of VDD is achieved when the PWM duty cycle is set to 100%. The optional feedback capacitor  $C_F$  forms a low-pass filter together with the feedback resistor  $R_F$ , and therefore, the output differential voltage is a function of the average value of the input PWM signal. When driving a motor, design the cutoff frequency of the low-pass filter to be sufficiently *lower than* the PWM frequency in order to eliminate the PWM frequency and its harmonics from entering the motor. This is desirable when driving motors which do not sufficiently reject the PWM frequency by themselves. When driving a linear vibrator in this configuration, if the feedback capacitor  $C_F$  is used, care must be taken to make sure that the low-pass cutoff frequency is *higher than* the resonant frequency of the linear vibrator.

When driving motors which can sufficiently reject the PWM frequency by themselves, the feedback capacitor may be eliminated. For this example, the output voltage is given by:

$$V_{O,DIFF} = 2 \times \left( V_{IN} - \frac{V_{DD}}{2} \right) \times \frac{R_F}{R_I} \tag{2}$$

where the only difference from Equation 1 is that the filtering action of the capacitor is not present.

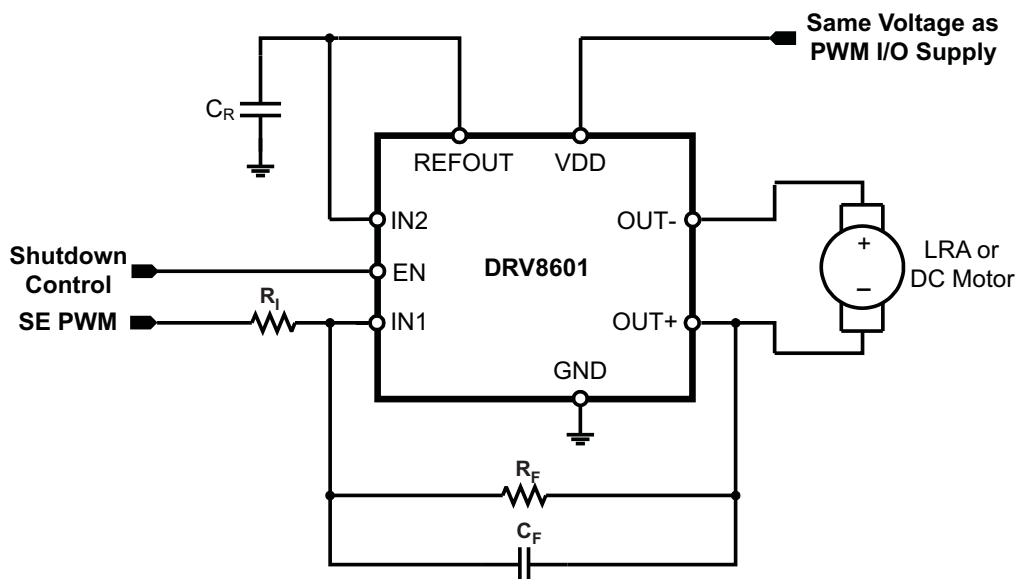

Figure 15. Pseudo-Differential Feedback with Internal Reference

## PSEUDO-DIFFERENTIAL FEEDBACK WITH LEVEL-SHIFTER

This configuration is desirable when a regulated supply voltage for the DRV8601 (VDD) is available, but that voltage is different than the PWM input voltage ( $V_{P_{PWM}}$ ). A single NPN transistor can be used as a low-cost level shifting solution. This ensures that  $V_{IN} = VDD$  even when  $V_{P_{PWM}} \neq VDD$ . A regulated supply for the DRV8601 is still recommended in this scenario. If the supply voltage varies, the PWM level shifter will follow, and this will, in turn, cause a change in vibration strength. However, if the variance is acceptable, the DRV8601 will still operate properly when connected directly to a battery, for example. A 50% duty cycle will still translate to zero vibration strength across the life cycle of the battery.  $R_F$  is normally set equal to  $R_I$  ( $R_F = R_I$ ) so that an overdrive voltage of VDD is achieved when the PWM duty cycle is set to 100%.

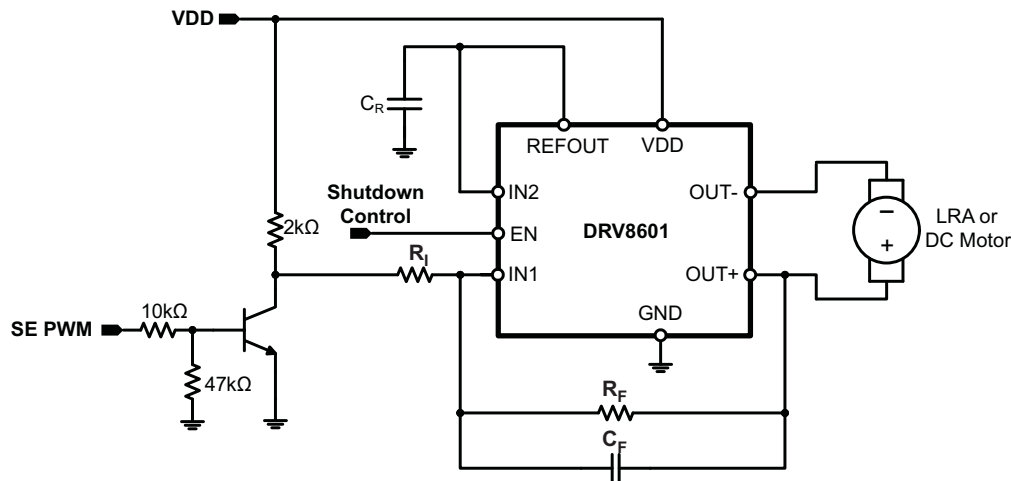

Figure 16. Pseudo-Differential Feedback with Level-Shifter

## DIFFERENTIAL FEEDBACK WITH EXTERNAL REFERENCE

This configuration is useful for connecting the DRV8601 to an unregulated power supply, most commonly a battery. The gain can then be independently set so that the required motor overdrive voltage can be achieved even when  $V_{P_{PWM}} < VDD$ . This is often the case when  $V_{P_{PWM}} = 1.8\text{ V}$ , and the desired overdrive voltage is 3.0 V or above. Note that VDD must be greater than or equal to the desired overdrive voltage. A resistor divider can be used to create a  $V_{P_{PWM}}/2$  reference for the DRV8601. If the shutdown control voltage is driven by a GPIO in the same supply domain as  $V_{P_{PWM}}$ , it can be used to supply the resistor divider as in Figure 17 so that no current is drawn by the divider in shutdown.

In this configuration, feedback is taken from both output pins. The output voltage is given by Equation 3 (where  $s$  is the Laplace Transform variable and  $V_{IN}$  is the single-ended input voltage):

$$V_{O,DIFF} = \left( V_{IN} - \frac{V_{P_{PWM}}}{2} \right) \times \frac{R_F}{R_I} \times \frac{1}{1 + sR_F C_F} \quad (3)$$

Note that this differs from Equation 1 for the pseudo-differential configuration by a factor of 2 because of differential feedback. The optional feedback capacitor  $C_F$  forms a low-pass filter together with the feedback resistor  $R_F$ , and therefore, the output differential voltage is a function of the average value of the input PWM signal  $V_{IN}$ . When driving a motor, design the cutoff frequency of the low-pass filter to be sufficiently *lower than* the PWM frequency in order to eliminate the PWM frequency and its harmonics from entering the motor. This is desirable when driving motors which do not sufficiently reject the PWM frequency by themselves. When driving a linear vibrator in this configuration, if the feedback capacitor  $C_F$  is used, care must be taken to make sure that the low-pass cutoff frequency is *higher than* the resonant frequency of the linear vibrator.

When driving motors which can sufficiently reject the PWM frequency by themselves, the feedback capacitor may be eliminated. For this example, the output voltage is given by:

$$V_{O,DIFF} = \left( V_{IN} - \frac{V_{PWM}}{2} \right) \times \frac{R_F}{R_I} \tag{4}$$

where the only difference from Equation 3 is that the filtering action of the capacitor is not present.

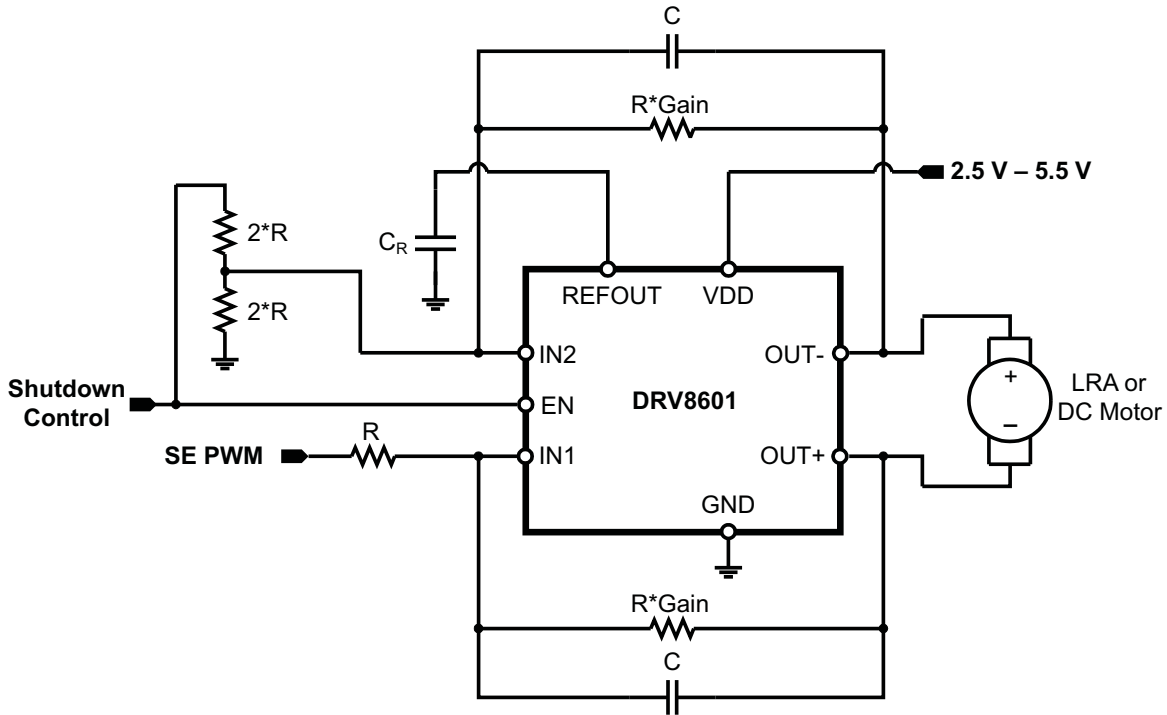

Figure 17. Differential Feedback with External Reference

## SELECTING COMPONENTS

### Resistors $R_I$ and $R_F$

Choose  $R_F$  and  $R_I$  in the range 20 k $\Omega$  – 100 k $\Omega$  for stable operation.

### Capacitor $C_R$

This capacitor filters any noise on the reference voltage generated by the DRV8601 on the REFOUT pin, thereby increasing noise immunity. However, a high value of capacitance results in a large turn-on time. A typical value of 1 nF is recommended for a fast turn-on time. All capacitors should be X5R dielectric or better.

## ZQV LAND PATTERN

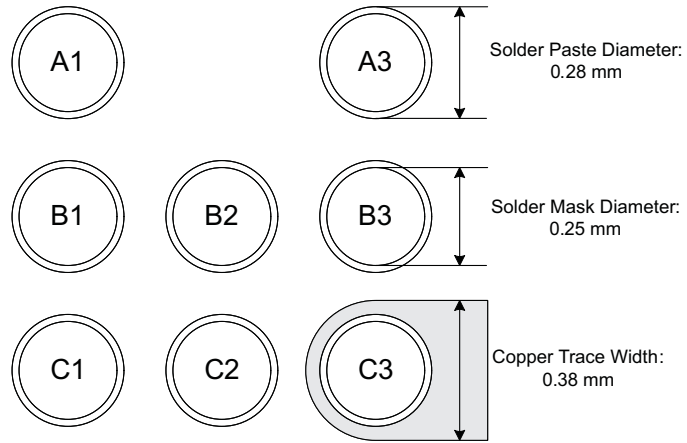

## REVISION HISTORY

Note: Page numbers of current version may differ from previous versions.

<b>Changes from Original (July 2010) to Revision A</b>	<b>Page</b>
• Added DRB package .....	1
• Changed the Application Information section for clarity .....	7
• Added polarity to motor in application diagrams, <a href="#">Figure 15</a> , <a href="#">Figure 16</a> , <a href="#">Figure 17</a> . ....	8
• Added ZQV Land Pattern .....	11

<b>Changes from Revision A (May 2011) to Revision B</b>	<b>Page</b>
• Changed R <sub>I</sub> value from 49.9 kΩ to 100 kΩ in Conditions statement for TYPICAL CHARACTERISTICS section. ....	4

**PACKAGING INFORMATION**

Orderable Device	Status <sup>(1)</sup>	Package Type	Package Drawing	Pins	Package Qty	Eco Plan <sup>(2)</sup>	Lead/ Ball Finish	MSL Peak Temp <sup>(3)</sup>	Samples (Requires Login)
DRV8601DRBR	ACTIVE	SON	DRB	8	3000	Green (RoHS & no Sb/Br)	CU NIPDAU	Level-2-260C-1 YEAR	
DRV8601DRBT	ACTIVE	SON	DRB	8	250	Green (RoHS & no Sb/Br)	CU NIPDAU	Level-2-260C-1 YEAR	
DRV8601ZQVR	ACTIVE	BGA MICROSTAR JUNIOR	ZQV	8	2500	Green (RoHS & no Sb/Br)	SNAGCU	Level-2-260C-1 YEAR	

<sup>(1)</sup> The marketing status values are defined as follows:

**ACTIVE:** Product device recommended for new designs.

**LIFEBUY:** TI has announced that the device will be discontinued, and a lifetime-buy period is in effect.

**NRND:** Not recommended for new designs. Device is in production to support existing customers, but TI does not recommend using this part in a new design.

**PREVIEW:** Device has been announced but is not in production. Samples may or may not be available.

**OBSELETE:** TI has discontinued the production of the device.

<sup>(2)</sup> Eco Plan - The planned eco-friendly classification: Pb-Free (RoHS), Pb-Free (RoHS Exempt), or Green (RoHS & no Sb/Br) - please check <http://www.ti.com/productcontent> for the latest availability information and additional product content details.

**TBD:** The Pb-Free/Green conversion plan has not been defined.

**Pb-Free (RoHS):** TI's terms "Lead-Free" or "Pb-Free" mean semiconductor products that are compatible with the current RoHS requirements for all 6 substances, including the requirement that lead not exceed 0.1% by weight in homogeneous materials. Where designed to be soldered at high temperatures, TI Pb-Free products are suitable for use in specified lead-free processes.

**Pb-Free (RoHS Exempt):** This component has a RoHS exemption for either 1) lead-based flip-chip solder bumps used between the die and package, or 2) lead-based die adhesive used between the die and leadframe. The component is otherwise considered Pb-Free (RoHS compatible) as defined above.

**Green (RoHS & no Sb/Br):** TI defines "Green" to mean Pb-Free (RoHS compatible), and free of Bromine (Br) and Antimony (Sb) based flame retardants (Br or Sb do not exceed 0.1% by weight in homogeneous material)

<sup>(3)</sup> MSL, Peak Temp. -- The Moisture Sensitivity Level rating according to the JEDEC industry standard classifications, and peak solder temperature.

**Important Information and Disclaimer:** The information provided on this page represents TI's knowledge and belief as of the date that it is provided. TI bases its knowledge and belief on information provided by third parties, and makes no representation or warranty as to the accuracy of such information. Efforts are underway to better integrate information from third parties. TI has taken and continues to take reasonable steps to provide representative and accurate information but may not have conducted destructive testing or chemical analysis on incoming materials and chemicals. TI and TI suppliers consider certain information to be proprietary, and thus CAS numbers and other limited information may not be available for release.

In no event shall TI's liability arising out of such information exceed the total purchase price of the TI part(s) at issue in this document sold by TI to Customer on an annual basis.

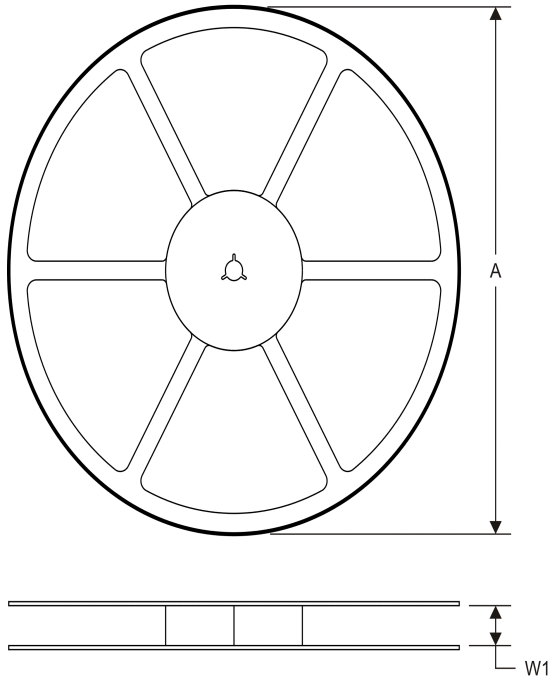
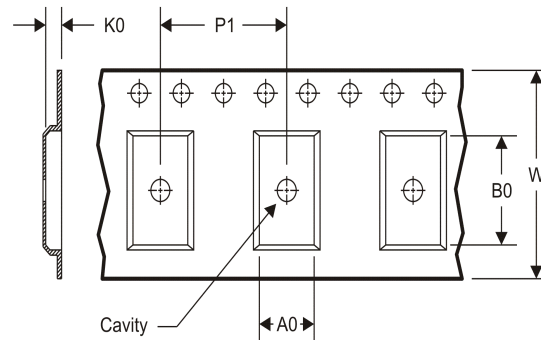
**TAPE AND REEL INFORMATION**
**REEL DIMENSIONS**

**TAPE DIMENSIONS**

A0	Dimension designed to accommodate the component width
B0	Dimension designed to accommodate the component length
K0	Dimension designed to accommodate the component thickness
W	Overall width of the carrier tape
P1	Pitch between successive cavity centers

**TAPE AND REEL INFORMATION**

\*All dimensions are nominal

Device	Package Type	Package Drawing	Pins	SPQ	Reel Diameter (mm)	Reel Width W1 (mm)	A0 (mm)	B0 (mm)	K0 (mm)	P1 (mm)	W (mm)	Pin1 Quadrant
DRV8601DRBR	SON	DRB	8	3000	330.0	12.4	3.3	3.3	1.1	8.0	12.0	Q2
DRV8601DRBT	SON	DRB	8	250	180.0	12.4	3.3	3.3	1.1	8.0	12.0	Q2
DRV8601ZQVR	BGA MICROSTAR JUNIOR	ZQV	8	2500	330.0	8.4	2.3	2.3	1.4	4.0	8.0	Q1
DRV8601ZQVR	BGA MICROSTAR JUNIOR	ZQV	8	2500	330.0	8.4	2.3	2.3	1.4	4.0	8.0	Q1

**TAPE AND REEL BOX DIMENSIONS**

\*All dimensions are nominal

Device	Package Type	Package Drawing	Pins	SPQ	Length (mm)	Width (mm)	Height (mm)
DRV8601DRBR	SON	DRB	8	3000	346.0	346.0	29.0
DRV8601DRBT	SON	DRB	8	250	210.0	185.0	35.0
DRV8601ZQVR	BGA MICROSTAR JUNIOR	ZQV	8	2500	340.5	333.0	20.6
DRV8601ZQVR	BGA MICROSTAR JUNIOR	ZQV	8	2500	340.5	333.0	20.6

## ZQV (S-PBGA-N8)

## PLASTIC BALL GRID ARRAY

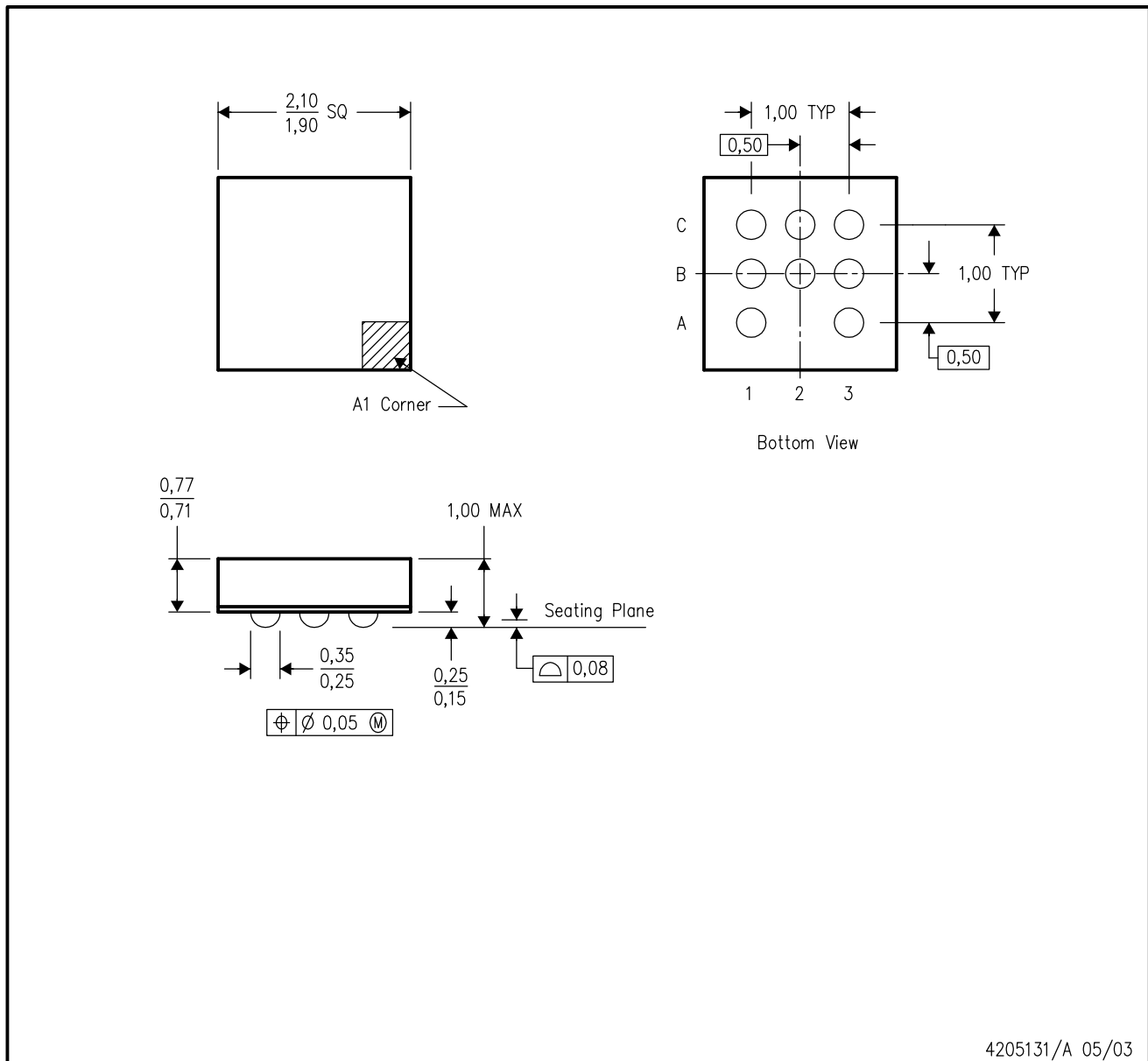

- NOTES:
- All linear dimensions are in millimeters.
  - This drawing is subject to change without notice.
  - MicroStar Junior configuration
  - Falls within JEDEC MO-225
  - This package is lead-free.

DRB (S-PVSON-N8)

PLASTIC SMALL OUTLINE NO-LEAD

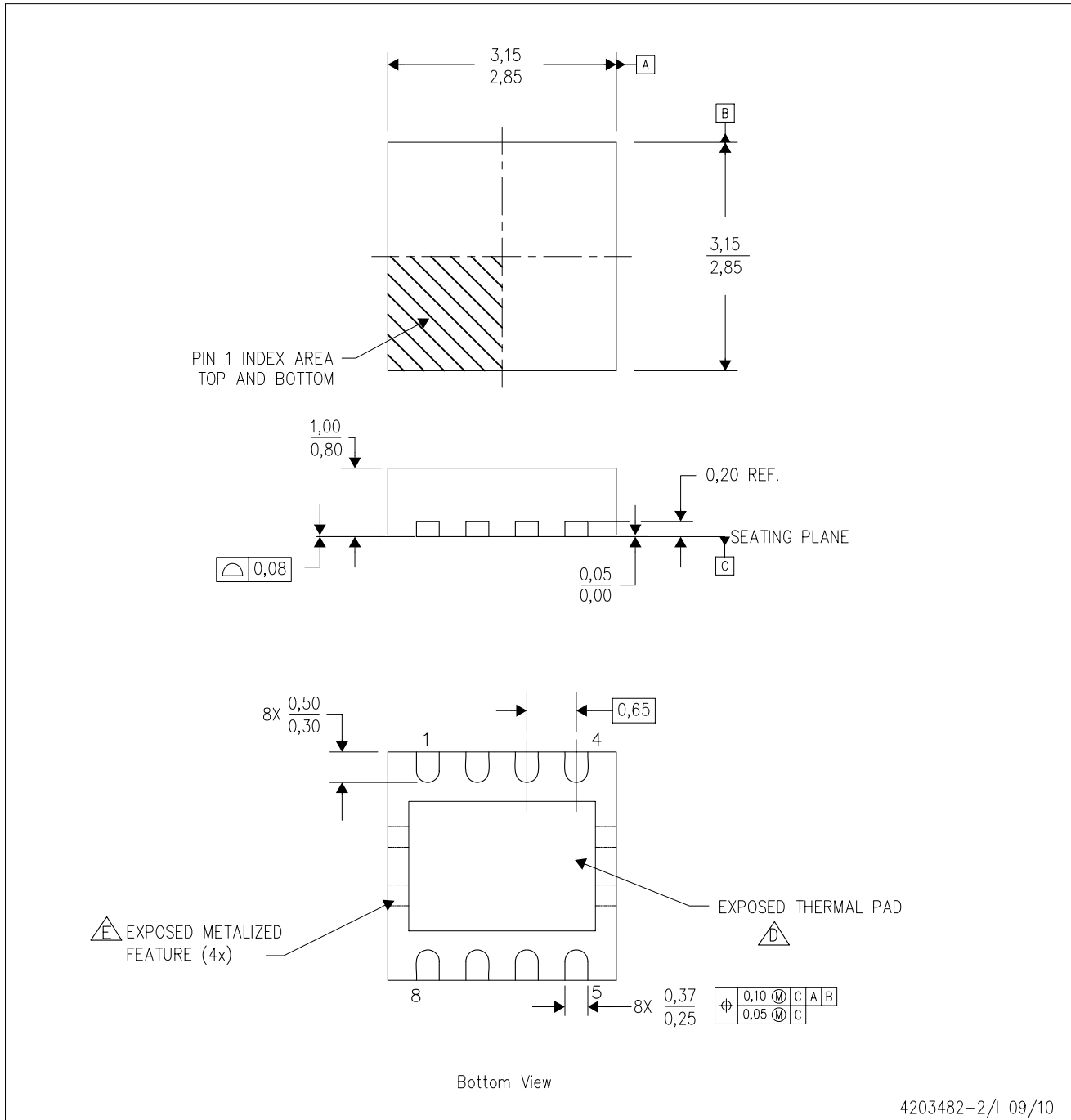

- NOTES:
- A. All linear dimensions are in millimeters. Dimensioning and tolerancing per ASME Y14.5M-1994.
  - B. This drawing is subject to change without notice.
  - C. Small Outline No-Lead (SON) package configuration.
  - The package thermal pad must be soldered to the board for thermal and mechanical performance.
  - See the Product Data Sheet for details regarding the exposed thermal pad features and dimensions.

# THERMAL PAD MECHANICAL DATA

DRB (S-PVSON-N8)

PLASTIC SMALL OUTLINE NO-LEAD

## THERMAL INFORMATION

This package incorporates an exposed thermal pad that is designed to be attached directly to an external heatsink. The thermal pad must be soldered directly to the printed circuit board (PCB). After soldering, the PCB can be used as a heatsink. In addition, through the use of thermal vias, the thermal pad can be attached directly to the appropriate copper plane shown in the electrical schematic for the device, or alternatively, can be attached to a special heatsink structure designed into the PCB. This design optimizes the heat transfer from the integrated circuit (IC).

For information on the Quad Flatpack No-Lead (QFN) package and its advantages, refer to Application Report, QFN/SON PCB Attachment, Texas Instruments Literature No. SLUA271. This document is available at [www.ti.com](http://www.ti.com).

The exposed thermal pad dimensions for this package are shown in the following illustration.

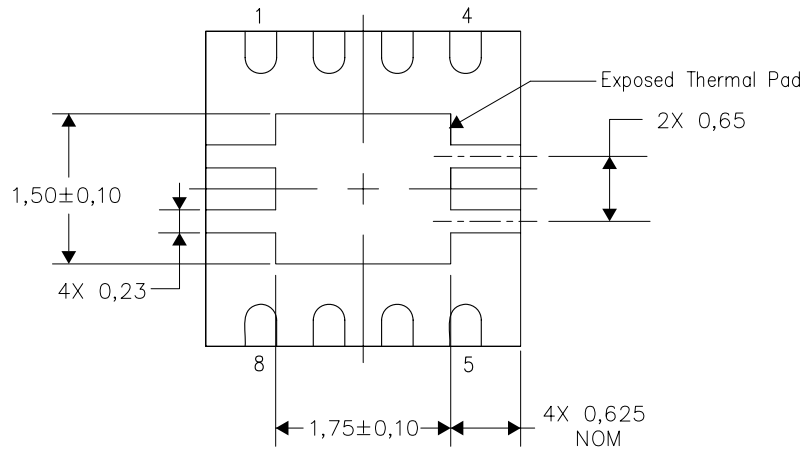

Bottom View

Exposed Thermal Pad Dimensions

4206340-2/L 12/10

NOTE: A. All linear dimensions are in millimeters

DRB (S-PVSON-N8)

PLASTIC SMALL OUTLINE NO-LEAD

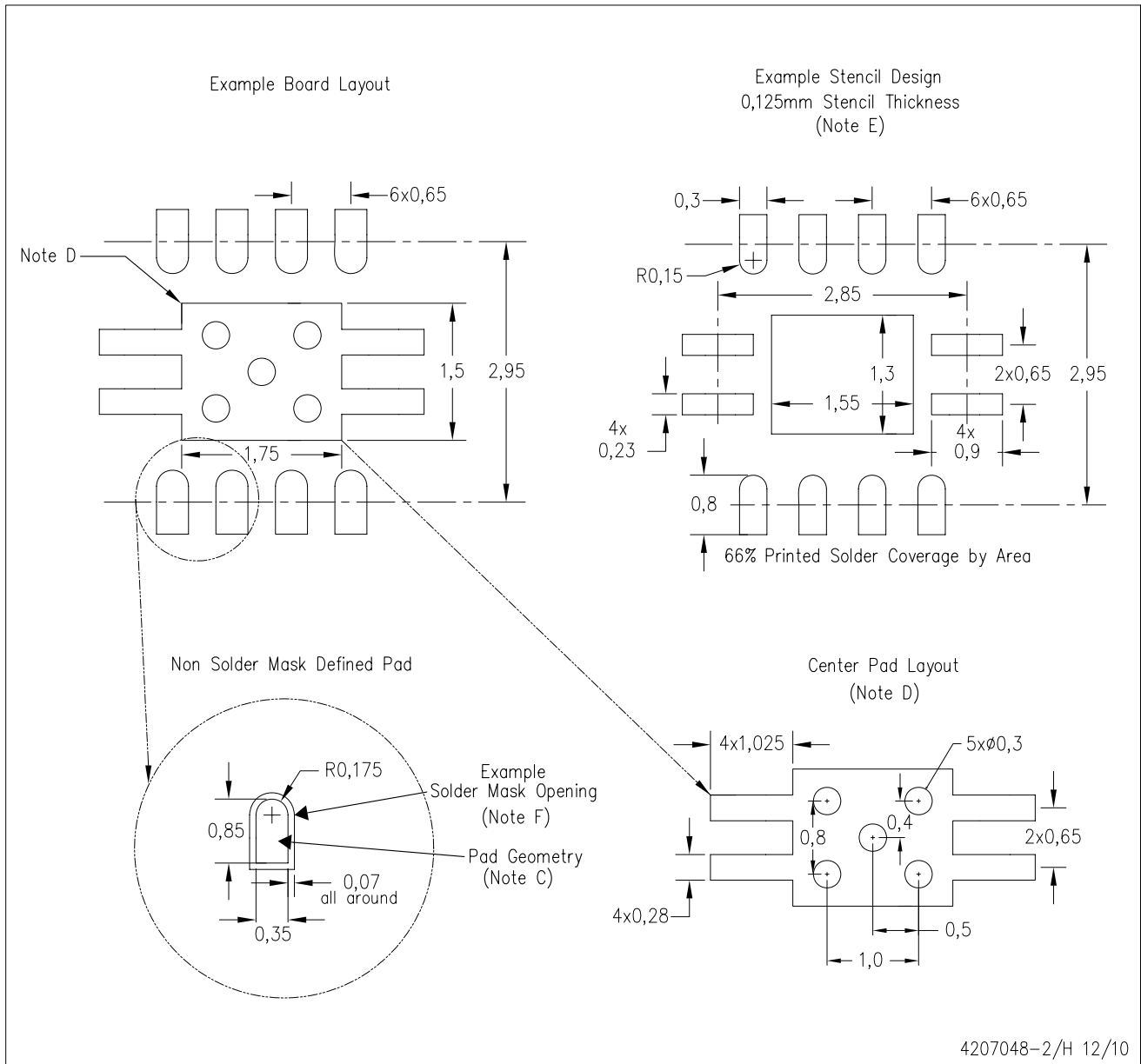

- NOTES:
- All linear dimensions are in millimeters.
  - This drawing is subject to change without notice.
  - Publication IPC-7351 is recommended for alternate designs.
  - This package is designed to be soldered to a thermal pad on the board. Refer to Application Note, QFN Packages, Texas Instruments Literature No. SLUA271, and also the Product Data Sheets for specific thermal information, via requirements, and recommended board layout. These documents are available at [www.ti.com](http://www.ti.com) <<http://www.ti.com>>.
  - Laser cutting apertures with trapezoidal walls and also rounding corners will offer better paste release. Customers should contact their board assembly site for stencil design recommendations. Refer to IPC 7525 for stencil design considerations.
  - Customers should contact their board fabrication site for solder mask tolerances.

## IMPORTANT NOTICE

Texas Instruments Incorporated and its subsidiaries (TI) reserve the right to make corrections, modifications, enhancements, improvements, and other changes to its products and services at any time and to discontinue any product or service without notice. Customers should obtain the latest relevant information before placing orders and should verify that such information is current and complete. All products are sold subject to TI's terms and conditions of sale supplied at the time of order acknowledgment.

TI warrants performance of its hardware products to the specifications applicable at the time of sale in accordance with TI's standard warranty. Testing and other quality control techniques are used to the extent TI deems necessary to support this warranty. Except where mandated by government requirements, testing of all parameters of each product is not necessarily performed.

TI assumes no liability for applications assistance or customer product design. Customers are responsible for their products and applications using TI components. To minimize the risks associated with customer products and applications, customers should provide adequate design and operating safeguards.

TI does not warrant or represent that any license, either express or implied, is granted under any TI patent right, copyright, mask work right, or other TI intellectual property right relating to any combination, machine, or process in which TI products or services are used. Information published by TI regarding third-party products or services does not constitute a license from TI to use such products or services or a warranty or endorsement thereof. Use of such information may require a license from a third party under the patents or other intellectual property of the third party, or a license from TI under the patents or other intellectual property of TI.

Reproduction of TI information in TI data books or data sheets is permissible only if reproduction is without alteration and is accompanied by all associated warranties, conditions, limitations, and notices. Reproduction of this information with alteration is an unfair and deceptive business practice. TI is not responsible or liable for such altered documentation. Information of third parties may be subject to additional restrictions.

Resale of TI products or services with statements different from or beyond the parameters stated by TI for that product or service voids all express and any implied warranties for the associated TI product or service and is an unfair and deceptive business practice. TI is not responsible or liable for any such statements.

TI products are not authorized for use in safety-critical applications (such as life support) where a failure of the TI product would reasonably be expected to cause severe personal injury or death, unless officers of the parties have executed an agreement specifically governing such use. Buyers represent that they have all necessary expertise in the safety and regulatory ramifications of their applications, and acknowledge and agree that they are solely responsible for all legal, regulatory and safety-related requirements concerning their products and any use of TI products in such safety-critical applications, notwithstanding any applications-related information or support that may be provided by TI. Further, Buyers must fully indemnify TI and its representatives against any damages arising out of the use of TI products in such safety-critical applications.

TI products are neither designed nor intended for use in military/aerospace applications or environments unless the TI products are specifically designated by TI as military-grade or "enhanced plastic." Only products designated by TI as military-grade meet military specifications. Buyers acknowledge and agree that any such use of TI products which TI has not designated as military-grade is solely at the Buyer's risk, and that they are solely responsible for compliance with all legal and regulatory requirements in connection with such use.

TI products are neither designed nor intended for use in automotive applications or environments unless the specific TI products are designated by TI as compliant with ISO/TS 16949 requirements. Buyers acknowledge and agree that, if they use any non-designated products in automotive applications, TI will not be responsible for any failure to meet such requirements.

Following are URLs where you can obtain information on other Texas Instruments products and application solutions:

### Products

Audio	<a href="http://www.ti.com/audio">www.ti.com/audio</a>
Amplifiers	<a href="http://amplifier.ti.com">amplifier.ti.com</a>
Data Converters	<a href="http://dataconverter.ti.com">dataconverter.ti.com</a>
DLP® Products	<a href="http://www.dlp.com">www.dlp.com</a>
DSP	<a href="http://dsp.ti.com">dsp.ti.com</a>
Clocks and Timers	<a href="http://www.ti.com/clocks">www.ti.com/clocks</a>
Interface	<a href="http://interface.ti.com">interface.ti.com</a>
Logic	<a href="http://logic.ti.com">logic.ti.com</a>
Power Mgmt	<a href="http://power.ti.com">power.ti.com</a>
Microcontrollers	<a href="http://microcontroller.ti.com">microcontroller.ti.com</a>
RFID	<a href="http://www.ti-rfid.com">www.ti-rfid.com</a>
OMAP Mobile Processors	<a href="http://www.ti.com/omap">www.ti.com/omap</a>
Wireless Connectivity	<a href="http://www.ti.com/wirelessconnectivity">www.ti.com/wirelessconnectivity</a>

### Applications

Automotive and Transportation	<a href="http://www.ti.com/automotive">www.ti.com/automotive</a>
Communications and Telecom	<a href="http://www.ti.com/communications">www.ti.com/communications</a>
Computers and Peripherals	<a href="http://www.ti.com/computers">www.ti.com/computers</a>
Consumer Electronics	<a href="http://www.ti.com/consumer-apps">www.ti.com/consumer-apps</a>
Energy and Lighting	<a href="http://www.ti.com/energy">www.ti.com/energy</a>
Industrial	<a href="http://www.ti.com/industrial">www.ti.com/industrial</a>
Medical	<a href="http://www.ti.com/medical">www.ti.com/medical</a>
Security	<a href="http://www.ti.com/security">www.ti.com/security</a>
Space, Avionics and Defense	<a href="http://www.ti.com/space-avionics-defense">www.ti.com/space-avionics-defense</a>
Video and Imaging	<a href="http://www.ti.com/video">www.ti.com/video</a>

TI E2E Community Home Page

[e2e.ti.com](http://e2e.ti.com)

Mailing Address: Texas Instruments, Post Office Box 655303, Dallas, Texas 75265  
Copyright © 2012, Texas Instruments Incorporated