

THREE PHASE PRE-DRIVER WITH DUAL CURRENT SHUNT AMPLIFIERS

Check for Samples: [DRV8303](#)

FEATURES

- Operating Supply Voltage 6V–60V
- 2.3A Sink and 1.7A Source Gate Drive Current Capability
- Integrated Dual Shunt Current Amplifiers With Adjustable Gain and Offset
- Independent Control of 3 or 6 PWM Inputs
- Bootstrap Gate Driver With 100% Duty Cycle Support
- Programmable Dead Time to Protect External FETs from Shoot Through
- Slew Rate Control for EMI Reduction
- Programmable Overcurrent Protection of External MOSFETs
- Support Both 3.3V and 5V Digital Interface
- SPI Interface
- Thermally Enhanced 48-Pin TSSOP Pad Down DCA Package

APPLICATIONS

- 3-Phase Brushless DC Motor and Permanent Magnet Synchronous Motor
- CPAP and Pump
- E-bike, Hospital Bed, Wheel Chair
- Power Drill, Blender, Chopper

DESCRIPTION

The DRV8303 is a gate driver IC for three phase motor drive applications. It provides three half bridge drivers, each capable of driving two N-type MOSFETs, one for the high-side and one for the low side. It supports up to 2.3A sink and 1.7A source peak current capability and only needs a single power supply with a wide range from 6V to 60V. The DRV8303 uses bootstrap gate drivers with trickle charge circuitry to support 100% duty cycle. The gate driver uses automatic hand shaking when high side FET or low side FET is switching to prevent current shoot through. Vds of FETs is sensed to protect external power stage during overcurrent conditions.

The DRV8303 includes two current shunt amplifiers for accurate current measurement. The current amplifiers support bi-directional current sensing and provide an adjustable output offset of up to 3V.

The SPI interface provides detailed fault reporting and flexible parameter settings such as gain options for current shunt amplifier and slew rate control of gate driver.

PRODUCT PREVIEW

Figure 1. DRV8303 Simplified Application Schematic



Please be aware that an important notice concerning availability, standard warranty, and use in critical applications of Texas Instruments semiconductor products and disclaimers thereto appears at the end of this data sheet.

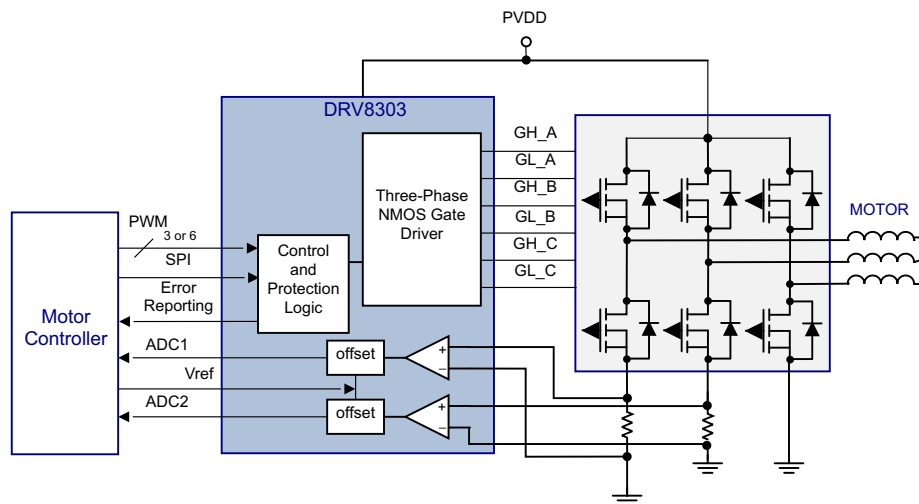

These devices have limited built-in ESD protection. The leads should be shorted together or the device placed in conductive foam during storage or handling to prevent electrostatic damage to the MOS gates.

DEVICE INFORMATION

PIN ASSIGNMENT

The DRV8303 is designed to fit the 48pin DCA package. Here is the pinout of the device.

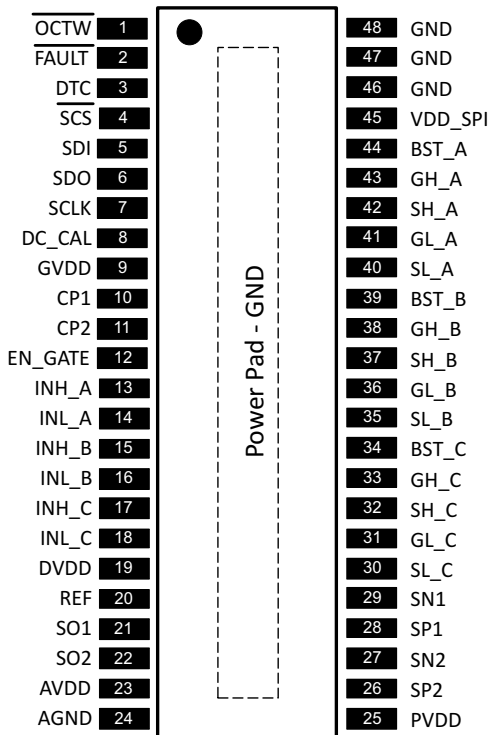

PRODUCT PREVIEW

PIN FUNCTIONS

PIN		I/O ⁽¹⁾	DESCRIPTION
NAME	NO.		
$\overline{\text{OCTW}}$	1	O	Over current or/and over temperature warning indicator. This output is open drain with external pull-up resistor required. Programmable output mode via SPI registers.
$\overline{\text{FAULT}}$	2	O	Fault report indicator. This output is open drain with external pull-up resistor required.
DTC	3	I	Dead-time adjustment with external resistor to GND
$\overline{\text{SCS}}$	4	I	SPI chip select
SDI	5	I	SPI input
SDO	6	O	SPI output
SCLK	7	I	SPI clock signal
DC_CAL	8	I	When DC_CAL is high, device shorts inputs of shunt amplifiers and disconnects loads. DC offset calibration can be done through external microcontroller.
GVDD	9	P	Internal gate driver voltage regulator. GVDD cap should connect to GND
CP1	10	P	Charge pump pin 1, ceramic cap should be used between CP1 and CP2
CP2	11	P	Charge pump pin 2, ceramic cap should be used between CP1 and CP2
EN_GATE	12	I	Enable gate driver and current shunt amplifiers.
INH_A	13	I	PWM Input signal (high side), half-bridge A
INL_A	14	I	PWM Input signal (low side), half-bridge A
INH_B	15	I	PWM Input signal (high side), half-bridge B
INL_B	16	I	PWM Input signal (low side), half-bridge B
INH_C	17	I	PWM Input signal (high side), half-bridge C
INL_C	18	I	PWM Input signal (low side), half-bridge C
DVDD	19	P	Internal 3.3V supply voltage. DVDD cap should connect to AGND. This is an output, but not specified to drive external circuitry.
REF	20	I	Reference voltage to set output of shunt amplifiers with a bias voltage which equals to half of the voltage set on this pin. Connect to ADC reference in microcontroller.
SO1	21	O	Output of current amplifier 1
SO2	22	O	Output of current amplifier 2
AVDD	23	P	Internal 6V supply voltage, AVDD cap should always be installed and connected to AGND. This is an output, but not specified to drive external circuitry.
AGND	24	P	Analog ground pin
PVDD	25	P	Power supply pin for gate driver, current shunt amplifier, and SPI communication. PVDD cap should connect to GND
SP2	26	I	Input of current amplifier 2 (connecting to positive input of amplifier). Recommend to connect to ground side of the sense resistor for the best common mode rejection.
SN2	27	I	Input of current amplifier 2 (connecting to negative input of amplifier).
SP1	28	I	Input of current amplifier 1 (connecting to positive input of amplifier). Recommend to connect to ground side of the sense resistor for the best common mode rejection.
SN1	29	I	Input of current amplifier 1 (connecting to negative input of amplifier).
SL_C	30	I	Low-Side MOSFET source connection, half-bridge C. Low-side V_{DS} measured between this pin and SH_C.
GL_C	31	O	Gate drive output for Low-Side MOSFET, half-bridge C
SH_C	32	I	High-Side MOSFET source connection, half-bridge C. High-side V_{DS} measured between this pin and PVDD.
GH_C	33	O	Gate drive output for High-Side MOSFET, half-bridge C
BST_C	34	P	Bootstrap cap pin for half-bridge C
SL_B	35	I	Low-Side MOSFET source connection, half-bridge B. Low-side V_{DS} measured between this pin and SH_B.
GL_B	36	O	Gate drive output for Low-Side MOSFET, half-bridge B
SH_B	37	I	High-Side MOSFET source connection, half-bridge B. High-side V_{DS} measured between this pin and PVDD.

(1) KEY: I = Input, O = Output, P = Power

PIN FUNCTIONS (continued)

PIN		I/O ⁽¹⁾	DESCRIPTION
NAME	NO.		
GH_B	38	O	Gate drive output for High-Side MOSFET, half-bridge B
BST_B	39	P	Bootstrap cap pin for half-bridge B
SL_A	40	I	Low-Side MOSFET source connection, half-bridge A. Low-side V_{DS} measured between this pin and SH_A.
GL_A	41	O	Gate drive output for Low-Side MOSFET, half-bridge A
SH_A	42	I	High-Side MOSFET source connection, half-bridge A. High-side V_{DS} measured between this pin and PVDD.
GH_A	43	O	Gate drive output for High-Side MOSFET, half-bridge A
BST_A	44	P	Bootstrap cap pin for half-bridge A
VDD_SPI	45	I	SPI supply pin to support 3.3V or 5V logic. Connect to either 3.3V or 5V.
GND (POWER PAD)	46, 47, 48, 49	O	GND pin. The exposed power pad must be electrically connected to ground plane through soldering to PCB for proper operation and connected to bottom side of PCB through vias for better thermal spreading.

FUNCTION BLOCK DIAGRAM

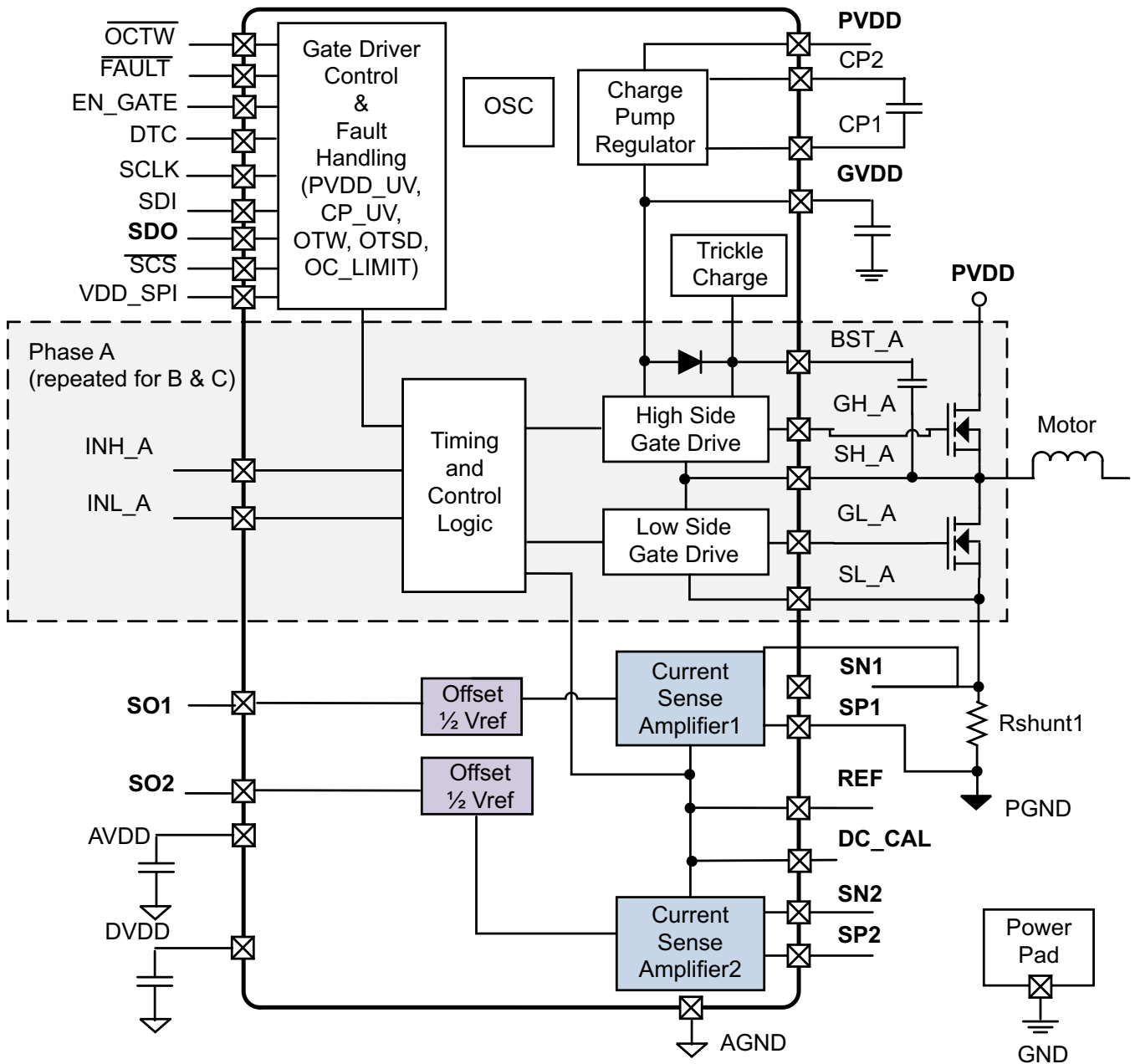

PRODUCT PREVIEW

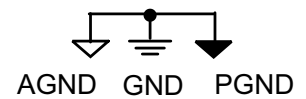

ABSOLUTE MAXIMUM RATINGS⁽¹⁾

			VALUE		UNITS
			MIN	MAX	
PVDD	Supply voltage range including transient	Relative to PGND	-0.3	70	V
PVDD _{RAMP}	Maximum supply voltage ramp rate	Voltage rising up to PVDD _{MAX}		1	V/μs
V _{PGND}	Maximum voltage between PGND and GND		±0.3		V
I _{IN_MAX}	Maximum current, all digital and analog input pins except $\overline{\text{FAULT}}$ and $\overline{\text{OCTW}}$ pins		±1		mA
I _{IN_OD_MAX}	Maximum sinking current for open drain pins ($\overline{\text{FAULT}}$ and $\overline{\text{OCTW}}$ Pins)		7		mA
V _{OPA_IN}	Voltage range for SPx and SNx pins		±0.6		V
V _{LOGIC}	Input voltage range for logic/digital pins (INH_A, INL_A, INH_B, INL_B, INH_C, INL_C, EN_GATE, SCLK, SDI, SCS, DC_CAL)		-0.3	7	V
V _{GVDD}	Maximum voltage for GVDD Pin		13.2		V
V _{AVDD}	Maximum voltage for AVDD Pin		8		V
V _{DVDD}	Maximum voltage for DVDD Pin		3.6		V
V _{VDD_SPI}	Maximum voltage for VDD_SPI Pin		7		V
V _{SDO}	Maximum voltage for SDO Pin		VDD_SPI +0.3		V
V _{REF}	Maximum reference voltage for current amplifier		7		V
I _{REF}	Maximum current for REF Pin		100		μA
T _J	Maximum operating junction temperature range		-40	150	°C
T _{STORAGE}	Storage temperature range		-55	150	°C
	Capacitive discharge model		500		V
	Human body model		2000		V

(1) Stresses beyond those listed under “absolute maximum ratings” may cause permanent damage to the device. These are stress ratings only, and functional operation of the device at these or any other conditions beyond those indicated under “recommended operating conditions” is not implied. Exposure to absolute-maximum-rated conditions for extended periods may affect device reliability.

THERMAL INFORMATION

THERMAL METRIC ⁽¹⁾		DRV8303	UNITS
		DCA (48) PINS	
θ _{JA}	Junction-to-ambient thermal resistance	30.3	°C/W
θ _{JCtop}	Junction-to-case (top) thermal resistance	33.5	
θ _{JB}	Junction-to-board thermal resistance	17.5	
ψ _{JT}	Junction-to-top characterization parameter	0.9	
ψ _{JB}	Junction-to-board characterization parameter	7.2	
θ _{JCbot}	Junction-to-case (bottom) thermal resistance	0.9	

(1) For more information about traditional and new thermal metrics, see the *IC Package Thermal Metrics* application report, [SPRA953](#).

RECOMMENDED OPERATING CONDITIONS

			MIN	TYP	MAX	UNITS
PVDD	DC supply voltage PVDD for normal operation	Relative to PGND	6		60	V
C _{PVDD}	External capacitance on PVDD pin (ceramic cap) 20% tolerance			4.7		μF
C _{AVDD}	External capacitance on AVDD pin (ceramic cap) 20% tolerance			1		μF
C _{DVDD}	External capacitance on DVDD pin (ceramic cap) 20% tolerance			1		μF
C _{GVDD}	External capacitance on GVDD pin (ceramic cap) 20% tolerance			2.2		μF
C _{CP}	Flying cap on charge pump pins (between CP1 and CP2) (ceramic cap) 20% tolerance			22	220	nF
C _{BST}	Bootstrap cap (ceramic cap)			100		nF
I _{DIN_EN}	Input current of digital pins when EN_GATE is high				100	μA
I _{DIN_DIS}	Input current of digital pins when EN_GATE is low				1	μA
C _{DIN}	Maximum capacitance on digital input pin				10	pF
C _{O_OPA}	Maximum output capacitance on outputs of shunt amplifier				20	pF
R _{DTC}	Dead time control resistor range. Time range is 50ns (-GND) to 500ns (150kΩ) with a linear approximation.		0		150	kΩ
I _{FAULT}	$\overline{\text{FAULT}}$ pin sink current. Open-drain	V = 0.4 V			2	mA
I _{OCTW}	$\overline{\text{OCTW}}$ pin sink current. Open-drain	V = 0.4 V			2	mA
V _{REF}	External voltage reference voltage for current shunt amplifiers		2		6	V
f _{gate}	Operating switching frequency of gate driver	Qg(TOT) = 25 nC or total 30 mA gate drive average current			200	kHz
I _{gate}	Total average gate drive current				30	mA
T _A	Ambient temperature		-40		125	°C

ELECTRICAL CHARACTERISTICS

 PVDD = 6 V to 60 V, T_C = 25°C, unless specified under test condition

PARAMETER	TEST CONDITIONS	MIN	TYP	MAX	UNIT
INPUT PINS: INH_X, INL_X, M_PWM (SCS), M_OC (SDI), GAIN(SDO), EN_GATE, DC_CAL					
V _{IH}	High input threshold	2			V
V _{IL}	Low input threshold			0.8	V
R _{EN_GATE}	Internal pull down resistor for EN_GATE		100		kΩ
R _{INH_X}	Internal pull down resistor for high side PWMs (INH_A, INH_B, and INH_C)	EN_GATE high	100		kΩ
R _{INL_X}	Internal pull down resistor for low side PWMs (INL_A, INL_B, and INL_C)	EN_GATE high	100		kΩ
R _{SCS}	Internal pull down resistor for $\overline{\text{SCS}}$	EN_GATE high	100		kΩ
R _{SDI}	Internal pull down resistor for SDI	EN_GATE high	100		kΩ
R _{DC_CAL}	Internal pull down resistor for DC_CAL	EN_GATE high	100		kΩ
R _{SCLK}	Internal pull down resistor for SCLK	EN_GATE high	100		kΩ
OUTPUT PINS: $\overline{\text{FAULT}}$ AND $\overline{\text{OCTW}}$					
V _{OL}	Low output threshold	I _O = 2 mA		0.4	V
V _{OH}	High output threshold	External 47 kΩ pull up resistor connected to 3-5.5 V	2.4		V
I _{OH}	Leakage Current on Open Drain Pins When Logic High ($\overline{\text{FAULT}}$ and $\overline{\text{OCTW}}$)			1	μA

ELECTRICAL CHARACTERISTICS (continued)PVDD = 6 V to 60 V, T_C = 25°C, unless specified under test condition

PARAMETER		TEST CONDITIONS	MIN	TYP	MAX	UNIT
GATE DRIVE OUTPUT: GH_A, GH_B, GH_C, GL_A, GL_B, GL_C						
V _{GX_NORM}	Gate driver V _{gs} voltage	PVDD = 8–60V, I _{gate} = 30mA , C _{CP} = 22nF	9.5		11.5	V
		PVDD = 8–60V, I _{gate} = 30mA , C _{CP} = 220nF	9.5		11.5	
V _{GX_MIN}	Gate driver V _{gs} voltage	PVDD = 6–8V, I _{gate} = 15mA , C _{CP} = 22nF	8.8			V
		PVDD = 6–8V, I _{gate} = 30mA , C _{CP} = 220nF	8.3			
I _{oso1}	Maximum source current setting 1, peak	V _{gs} of FET equals to 2 V. REG 0x02		1.7		A
I _{osi1}	Maximum sink current setting 1, peak	V _{gs} of FET equals to 8 V. REG 0x02		2.3		A
I _{oso2}	Source current setting 2, peak	V _{gs} of FET equals to 2 V. REG 0x02		0.7		A
I _{osi2}	Sink current setting 2, peak	V _{gs} of FET equals to 8 V. REG 0x02		1		A
I _{oso3}	Source current setting 3, peak	V _{gs} of FET equals to 2 V. REG 0x02		0.25		A
I _{osi3}	Sink current setting 3, peak	V _{gs} of FET equals to 8 V. REG 0x02		0.5		A
R _{gate_off}	Gate output impedance during standby mode when EN_GATE low (pins GH_x, GL_x)		1.6		2.4	kΩ
SUPPLY CURRENTS						
I _{PVDD_STB}	PVDD supply current, standby	EN_GATE is low. PVDD = 8V.		20	50	μA
I _{PVDD_OP}	PVDD supply current, operating	EN_GATE is high, no load on gate drive output, switching at 10 kHz, 100 nC gate charge		15		mA
I _{PVDD_HIz}	PVDD Supply current, HiZ	EN_GATE is high, gate not switching	2	5	10	mA
INTERNAL REGULATOR VOLTAGE						
A _{VDD}	AVDD voltage	PVDD = 8V - 60V	6	6.5	7	V
		PVDD = 6V - 8V	5.5		6	
D _{VDD}	DVDD voltage		3	3.3	3.6	V
VOLTAGE PROTECTION						
V _{PVDD_UV}	Under voltage protection limit, PVDD				6	V
V _{GVDD_UV}	Under voltage protection limit, GVDD				7.5	V
V _{GVDD_OV}	Over voltage protection limit, GVDD			16		V
CURRENT PROTECTION, (VDS SENSING)						
V _{DS_OC}	Drain-source voltage protection limit	PVDD = 8V - 60V	0.125		2.4	V
		PVDD = 6V - 8V ⁽¹⁾	0.125		1.491	
T _{oc}	OC sensing response time			1.5		μs
T _{OC_PULSE}	OC pin reporting pulse stretch length for OC event			64		μs

(1) Reduced A_{VDD} voltage range results in limitations on settings for over current protection. See [Table 10](#).

GATE TIMING AND PROTECTION CHARACTERISTICS

PARAMETER		TEST CONDITIONS	MIN	TYP	MAX	UNIT
TIMING, OUTPUT PINS						
$t_{pd,IF-O}$	Positive input falling to GH_x falling	CL=1nF, 50% to 50%		45		ns
$t_{pd,IR-O}$	Positive input rising to GL_x falling	CL=1nF, 50% to 50%		45		ns
T_{d_min}	Minimum dead time after hand shaking ⁽¹⁾				50	ns
T_{dtp}	Dead Time	With R_{DTC} set to different values	50		500	ns
t_{GDr}	Rise time, gate drive output	CL=1nF, 10% to 90%		25		ns
t_{GDF}	Fall time, gate drive output	CL=1nF, 90% to 10%		25		ns
T_{ON_MIN}	Minimum on pulse	Not including handshake communication. Hiz to on state, output of gate driver			50	ns
T_{pd_match}	Propagation delay matching between high side and low side				5	ns
T_{dt_match}	Deadtime matching				5	ns
TIMING, PROTECTION AND CONTROL						
$t_{pd,R_GATE-OP}$	Start up time, from EN_GATE active high to device ready for normal operation	PVDD is up before start up, all charge pump caps and regulator caps as in recommended condition		5	10	ms
$t_{pd,R_GATE-Quick}$	If EN_GATE goes from high to low and back to high state within quick reset time, it will only reset all faults and gate driver without powering down charge pump, current amp, and related internal voltage regulators.	Maximum low pulse time			10	us
$t_{pd,E-L}$	Delay, error event to all gates low			200		ns
$t_{pd,E-FAULT}$	Delay, error event to \overline{FAULT} low			200		ns
OTW_CLR	Junction temperature for resetting over temperature warning			115		°C
OTW_SET/OTSD_CLR	Junction temperature for over temperature warning and resetting over temperature shut down			130		°C
OTSD_SET	Junction temperature for over temperature shut down			150		°C

- (1) Dead time programming definition: Adjustable delay from GH_x falling edge to GL_X rising edge, and GL_X falling edge to GH_X rising edge. This is a minimum dead-time insertion. It is not added to the value set by the microcontroller externally.

CURRENT SHUNT AMPLIFIER CHARACTERISTICS

T_c = 25°C unless otherwise specified

PARAMETER		TEST CONDITIONS	MIN	TYP	MAX	UNIT
G1	Gain option 1	T _c = -40°C-125°C	9.5	10	10.5	V/V
G2	Gain option 2	T _c = -40°C-125°C	18	20	21	V/V
G3	Gain Option 3	T _c = -40°C-125°C	38	40	42	V/V
G4	Gain Option 4	T _c = -40°C-125°C	75	80	85	V/V
T _{settling}	Settling time to 1%	T _c = 0-60°C, G = 10, V _{step} = 2 V		300		ns
		T _c = 0-60°C, G = 20, V _{step} = 2 V		600		ns
		T _c = 0-60°C, G = 40, V _{step} = 2 V		1.2		μs
		T _c = 0-60°C, G = 80, V _{step} = 2 V		2.4		μs
V _{swing}	Output swing linear range		0.3		5.7	V
Slew Rate		G = 10		10		V/μs
DC_offset	Offset error RTI	G = 10 with input shorted			4	mV
Drift_offset	Offset drift RTI			10		μV/C
I _{bias}	Input bias current				100	μA
V _{in_com}	Common input mode range		-0.15		0.15	V
V _{in_dif}	Differential input range		-0.3		0.3	V
V _{o_bias}	Output bias	With zero input current, V _{ref} up to 6 V	-0.5%	0.5×V _{ref}	0.5%	V
CMRR_OV	Overall CMRR with gain resistor mismatch	CMRR at DC, gain = 10	70	85		dB

SPI CHARACTERISTICS (Slave Mode Only)

PARAMETER		TEST CONDITIONS	MIN	TYP	MAX	UNIT
t _{SPI_READY}	SPI ready after EN_GATE transitions to HIGH	PVDD > 6 V		5	10	ms
t _{CLK}	Minimum SPI clock period		100			ns
t _{CLKH}	Clock high time		40			
t _{CLKL}	Clock low time		40			
t _{SU_SDI}	SDI input data setup time		20			ns
t _{HD_SDI}	SDI input data hold time		30			ns
t _{D_SDO}	SDO output data delay time, CLK high to SDO valid	C _L = 20 pF			20	ns
t _{HD_SDO}	SDO output data hold time		40			
t _{SU_SCS}	SCS setup time		50			ns
t _{HD_SCS}	SCS hold time		50			ns
t _{HI_SCS}	SCS minimum high time before SCS active low		40			ns
t _{ACC}	SCS access time, SCS low to SDO out of high impedance			10		ns
t _{DIS}	SCS disable time, SCS high to SDO high impedance			10		ns

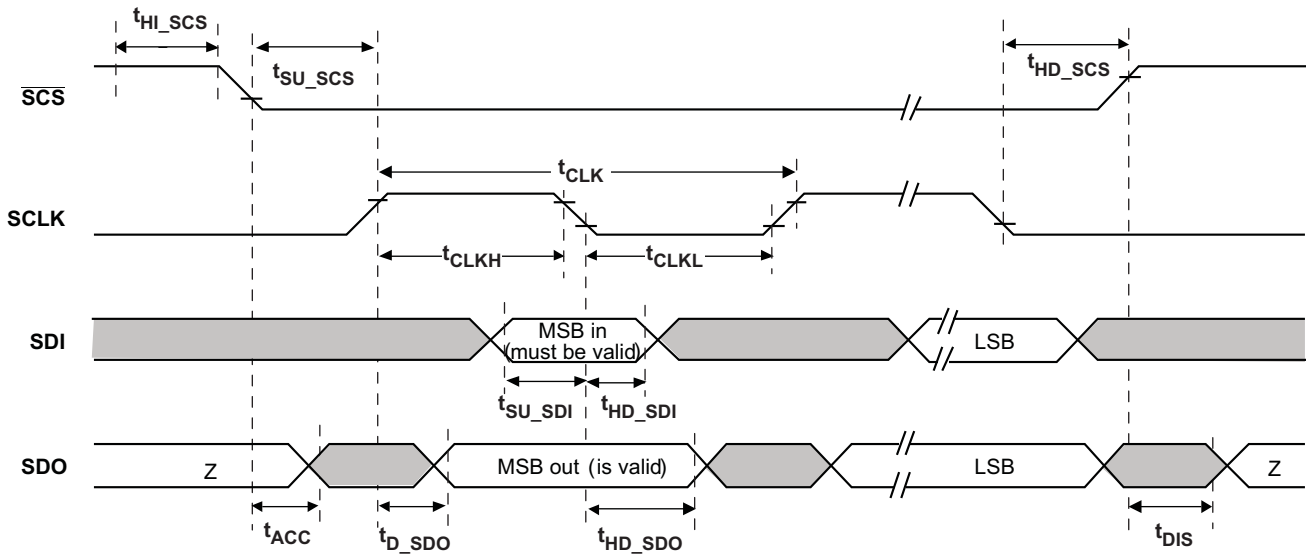

Figure 2. SPI Slave Mode Timing Definition

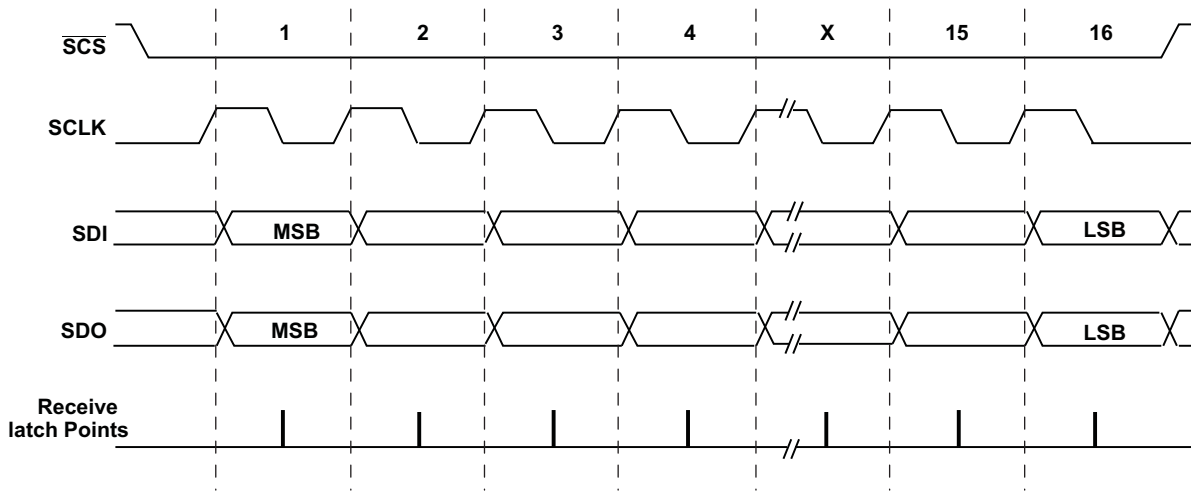

Figure 3. SPI Slave Mode Timing Diagram

PRODUCT PREVIEW

FUNCTIONAL DESCRIPTION

THREE-PHASE GATE DRIVER

The DRV8303 provides three half bridge drivers, each capable of driving two N-type MOSFETs, one for the high-side and one for the low side.

Gate driver has following features:

- Internal hand shake between high side and low side FETs during switching transition to prevent current shoot through.
- Programmable slew rate or current driving capability through SPI interface.
- Support up to 200kHz switching frequency with $Q_g(\text{TOT})=25\text{nC}$ or total 30mA gate drive average current
- Provide cycle-by-cycle current limiting and latch over-current (OC) shut down of external FETs. Current is sensed through FET drain-to-source voltage and the over-current level is programmable through SPI interface
- V_{ds} sensing range is programmable from 0.060V to 2.4V and with 5 bit programmable resolution through SPI.
- High side gate drive will survive negative output from half bridge up to -10V for 10ns
- During EN_GATE pin low and fault conditions, gate driver will keep external FETs in high impedance mode.
- Programmable dead time through DTC pin. Dead time control range: 50ns to 500ns. Short DTC pin to ground will provide minimum dead time (50ns). External dead time will override internal dead time as long as the time is longer than the dead time setting (minimum hand shake time cannot be reduced in order to prevent shoot through current).
- Bootstraps are used in high side FETs of three-phase pre-gate driver. Trickle charge circuitry is used to replenish current leakage from bootstrap cap and support 100% duty cycle operation.

CURRENT SHUNT AMPLIFIERS

The DRV8303 includes two high performance current shunt amplifiers for accurate current measurement. The current amplifiers provide output offset up to 3V to support bi-directional current sensing.

Current shunt amplifier has following features:

- Programmable gain: 4 gain settings through SPI command
- Programmable output offset through reference pin (half of the V_{ref})
- Minimize DC offset and drift over temperature with dc calibrating through SPI command or DC_CAL pin. When DC calibration is enabled, device will short input of current shunt amplifier and disconnect the load. DC calibrating can be done at anytime even when FET is switching since the load is disconnected. For best result, perform the DC calibrating during switching off period when no load is present to reduce the potential noise impact to the amplifier.

The output of current shunt amplifier can be calculated as:

$$V_O = \frac{V_{REF}}{2} - G \times (SN_x - SP_x) \quad (1)$$

Where V_{ref} is the reference voltage, G is the gain of the amplifier; SN_x and SP_x are the inputs of channel x . SP_x should connect to resistor ground for the best common mode rejection.

[Figure 4](#) shows current amplifier simplified block diagram.

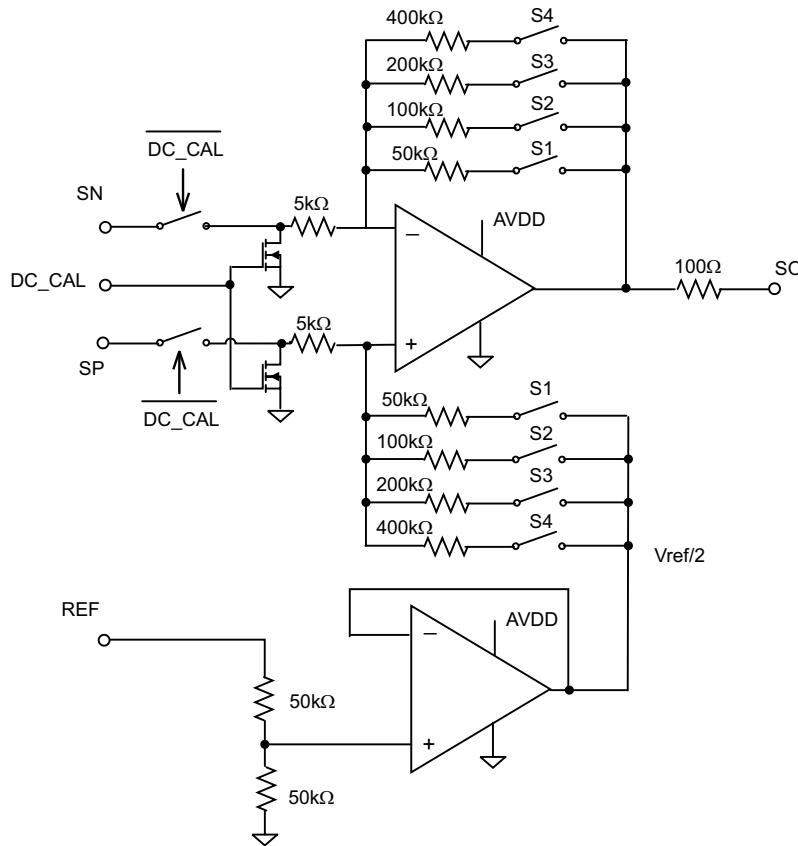

Figure 4. Current Shunt Amplifier Simplified Block Diagram

PROTECTION FEATURES

Power Stage Protection

The DRV8303 provides over-current and under-voltage protection for the MOSFET power stage. During fault shut down conditions, all gate driver outputs will be kept low to ensure external FETs at high impedance state.

Over-Current Protection (OCP) and Reporting

To protect the power stage from damage due to high currents, a V_{DS} sensing circuitry is implemented in the DRV8303. Based on $R_{DS(on)}$ of the power MOSFETs and the maximum allowed I_{DS} , a voltage threshold can be calculated which, when exceeded, triggers the OC protection feature. This voltage threshold level is programmable through SPI command.

There are total 4 OC_MODE settings in SPI.

1. Current Limit Mode

When current limit mode is enabled, device operates current limiting instead of OC shut down during OC event. The over-current event is reported through OCTW pin. OCTW reporting should hold low during same PWM cycle or for a max 64 μ s period (internal timer) so external controller has enough time to sample the warning signal. If in the middle of reporting, other FET(s) gets OC, then OCTW reporting will hold low and recount another 64 μ s unless PWM cycles on both FETs are ended.

There are two current control settings in current limit mode (selected by one bit in SPI and default is CBC mode).

- Setting 1 (CBC mode): during OC event, the FET that detected OC will turn off until next PWM cycle.
- Setting 2 (off-time control mode):
 - During OC event, the FET that detected OC will turn off for 64 μ s as off time and back to normal after

that (so same FET will be on again) if PWM signal is still holding high. Since all three phases or 6 FETs share a single timer, if more than one FET get OC, the FETs will not be back to normal until the all FETs that have OC event pass 64 μ s.

- If PWM signal is toggled for this FET during timer running period, device will resume normal operation for this toggled FET. So real off-time could be less than 64 μ s in this case.
- If two FETs get OC and one FET's PWM signal gets toggled during timer running period, this FET will be back to normal, and the other FET will be off till timer end (unless its PWM is also toggled)

2. OC latch shut down mode

When OC occurs, device will turn off both high side and low side FETs in the same phase if any of the FETs in that phase has OC.

3. Report only mode

No protection action will be performance in this mode. OC detection will be reported through OCTW pin and SPI status register. External MCU should take actions based on its own control algorithm. A pulse stretching of 64 μ s will be implemented on OCTW pin so controller can have enough time to sense the OC signal.

4. OC disable mode

Device will ignore all the OC detections and will not report them either.

Under-Voltage Protection (UVP)

To protect the power output stage during startup, shutdown and other possible under-voltage conditions, the DRV8303 provides power stage under-voltage protection by driving its outputs low whenever PVDD is below 6V (PVDD_UV) or GVDD is below 7.5V (GVDD_UV). When UVP is triggered, the DRV8303 outputs are driven low and the external MOSFETs will go to a high impedance state.

Over-Voltage Protection (GVDD_OV)

Device will shut down both gate driver and charge pump if GVDD voltage exceeds 16V to prevent potential issue related to GVDD or charge pump (e.g. short of external GVDD cap or charge pump). The fault is a latched fault and can only be reset through a transition on EN_GATE pin.

Over-Temperature Protection

A two-level over-temperature detection circuit is implemented:

- Level 1: over temperature warning (OTW)
OTW is reported through $\overline{\text{OCTW}}$ pin (over-current-temperature warning) for default setting. OCTW pin can be set to report OTW or OCW only through SPI command. See SPI Register section.
- Level 2: over temperature (OT) latched shut down of gate driver and charge pump (OTSD_GATE)
Fault will be reported to $\overline{\text{FAULT}}$ pin. This is a latched shut down, so gate driver will not be recovered automatically even OT condition is not present anymore. An EN_GATE reset through pin or SPI (RESET_GATE) is required to recover gate driver to normal operation after temperature goes below a preset value, $t_{\text{OTSD_CLR}}$.

SPI operation is still available and register settings will be remaining in the device during OTSD operation as long as PVDD is still within defined operation range.

Fault and Protection Handling

The $\overline{\text{FAULT}}$ pin indicates an error event with shut down has occurred such as over-current, over-temperature, over-voltage, or under-voltage. Note that FAULT is an open-drain signal. FAULT will go high when gate driver is ready for PWM signal (internal EN_GATE goes high) during start up.

The $\overline{\text{OCTW}}$ pin indicates over current event and over temperature event that not necessary related to shut down.

Following is the summary of all protection features and their reporting structure:

Table 1. Fault and Warning Reporting and Handling

EVENT	ACTION	LATCH	REPORTING ON FAULT PIN	REPORTING ON OCTW PIN	REPORTING IN SPI STATUS REGISTER
PVDD undervoltage	External FETs HiZ; Weak pull down of all gate driver output	N	Y	N	Y
DVDD undervoltage	External FETs HiZ; Weak pull down of all gate driver output; When recovering, reset all status registers	N	Y	N	N
GVDD undervoltage	External FETs HiZ; Weak pull down of all gate driver output	N	Y	N	Y
GVDD overvoltage	External FETs HiZ; Weak pull down of all gate driver output Shut down the charge pump Won't recover and reset through SPI reset command or quick EN_GATE toggling	Y	Y	N	Y
OTW	None	N	N	Y (in default setting)	Y
OTSD_GATE	Gate driver latched shut down. Weak pull down of all gate driver output to force external FETs HiZ Shut down the charge pump	Y	Y	Y	Y
External FET overload – current limit mode	External FETs current Limiting (only OC detected FET)	N	N	Y	Y, indicates which phase has OC
External FET overload – Latch mode	Weak pull down of gate driver output and PWM logic "0" of LS and HS in the same phase. External FETs HiZ	Y	Y	Y	Y
External FET overload – reporting only mode	Reporting only	N	N	Y	Y, indicates which phase has OC

PRODUCT PREVIEW

PIN CONTROL FUNCTIONS

Table 2. Device Truth Table

INH_X	INL_X	GH_X	GL_X
1	1	L	L
1	0	H	L
0	1	L	H
0	0	L	L

EN_GATE

EN_GATE low is used to put gate driver, charge pump, current shunt amplifier, and internal regulator blocks into a low power consumption mode to save energy. SPI communication is not supported during this state. Device will put the MOSFET output stage to high impedance mode as long as PVDD is still present.

When EN_GATE pin goes to high, it will go through a power up sequence, and enable gate driver, current amplifiers, charge pump, internal regulator, etc and reset all latched faults related to gate driver block. It will also reset status registers in SPI table. All latched faults can be reset when EN_GATE is toggled after an error event unless the fault is still present.

When EN_GATE goes from high to low, it will shut down gate driver block immediately, so gate output can put external FETs in high impedance mode. It will then wait for 10us before completely shutting down the rest of the blocks. A quick fault reset mode can be done by toggling EN_GATE pin for a very short period (less than 10µS). This will prevent device to shut down other function blocks such as charge pump and internal regulators and bring a quicker and simple fault recovery. SPI will still function with such a quick EN_GATE reset mode.

The other way to reset all the faults is to use SPI command (RESET_GATE), which will only reset gate driver block and all the SPI status registers without shutting down other function blocks.

One exception is to reset a GVDD_OV fault. A quick EN_GATE quick fault reset or SPI command reset won't work with GVDD_OV fault. A complete EN_GATE with low level holding longer than 10µS is required to reset GVDD_OV fault. It is highly recommended to inspect the system and board when GVDD_OV occurs.

DTC

Dead time can be programmed through DTC pin. A resistor should be connected from DTC to ground to control the dead time. Dead time control range is from 50ns to 500ns. Short DTC pin to ground will provide minimum dead time (50ns). Resistor range is 0 to 150kΩ. Dead time is linearly set over this resistor range.

Current shoot through prevention protection will be enabled in the device all time independent of dead time setting and input mode setting.

VDD_SPI

VDD_SPI is the power supply to power SDO pin. It has to be connected to the same power supply (3.3V or 5V) that MCU uses for its SPI operation.

During power up or down transient, VDD_SPI pin could be zero voltage shortly. During this period, no SDO signal should be present at SDO pin from any other devices in the system since it causes a parasitic diode in the DRV8303 conducting from SDO to VDD_SPI pin as a short. This should be considered and prevented from system power sequence design.

DC_CAL

When DC_CAL is enabled, device will short inputs of shunt amplifier and disconnect from the load, so external microcontroller can do a DC offset calibration. DC offset calibration can be also done with SPI command. If using SPI exclusively for DC calibration, the DC_CAL pin can connected to GND.

SPI Pins

SDO pin has to be 3-state, so a data bus line can be connected to multiple SPI slave devices. SCS pin is active low. When SCS is high, SDO is at high impedance mode.

STARTUP AND SHUTDOWN SEQUENCE CONTROL

During power-up all gate drive outputs are held low. Normal operation of gate driver and current shunt amplifiers can be initiated by toggling EN_GATE from a low state to a high state. If no errors are present, the DRV8303 is ready to accept PWM inputs. Gate driver always has control of the power FETs even in gate disable mode as long as PVDD is within functional region.

There is an internal diode from SDO to VDD_SPI, so VDD_SPI is required to be powered to the same power level as other SPI devices (if there is any SDO signal from other devices) all the time. VDD_SPI supply should be powered up first before any signal appears at SDO pin and powered down after completing all communications at SDO pin.

SPI COMMUNICATION

SPI Interface

SPI interface is used to set device configuration, operating parameters and read out diagnostic information. The DRV8303 SPI Interface operates in the slave mode.

The SPI input data (SDI) word consists of 16bit word, with 11 bit data and 5 bit (MSB) command. The SPI output data (SDO) word consists of 16bit word, with 11 bit register data and 4 bit MSB address data and 1 frame fault bit (active 1). When a frame is not valid, frame fault bit will set to 1, and rest of SDO bit will shift out zeros.

A valid frame has to meet following conditions:

1. Clock must be low when /SCS goes low.
2. We should have 16 full clock cycles.
3. Clock must be low when /SCS goes high.

When SCS is asserted high, any signals at the SCLK and SDI pins are ignored, and SDO is forced into a high impedance state. When SCS transitions from HIGH to LOW, SDO is enabled and the SPI response word loads into the shift register based on 5 bit command in SPI at previous clock cycle.

The SCLK pin must be low when SCS transitions low. While SCS is low, at each rising edge of the clock, the response bit is serially shifted out on the SDO pin with MSB shifted out first.

While SCS is low, at each falling edge of the clock, the new control bit is sampled on the SDI pin. The SPI command bits are decoded to determine the register address and access type (read or write). The MSB will be shifted in first. If the word sent to SDI is less than 16 bits or more than 16 bits, it is considered a frame error. If it is a write command, the data will be ignored. The fault bit in SDO (MSB) will report 1 at next 16 bit word cycle.

After the 16th clock cycle or when SCS transitions from LOW to HIGH, in case of write access type, the SPI receive shift register data is transferred into the latch where address matches decoded SPI command address value. Any amount of time may pass between bits, as long as SCS stays active low. This allows two 8-bit words to be used.

For a read command (Nth cycle) in SPI, SPO will send out data in the register with address in read command in next cycle (N+1).

For a write command in SPI, SPO will send out data in the status register 0x00h in next 16 bit word cycle (N+1). For most of the time, this feature will maximize SPI communication efficiency when having a write command, but still get fault status values back without sending extra read command.

SPI Format

SPI input data control word is 16-bit long, consisting of:

- 1 read or write bit W [15]
- 4 address bits A [14:11]
- 11 data bits D [10:0]

SPI output data response word is 16-bit long, and its content depends on the given SPI command (SPI Control Word) in the previous cycle. When a SPI Control Word is shifted in, the SPI Response Word (that is shifted out during the same transition time) is the response to the previous SPI Command (shift in SPI Control Word "N" and shift out SPI Response Word "N-1").

Therefore, each SPI Control / Response pair requires two full 16-bit shift cycles to complete.

Table 3. SPI Input Data Control Word Format

	R/W	Address					Data									
Word Bit	B15	B14	B13	B12	B11	B10	B9	B8	B7	B6	B5	B4	B3	B2	B1	B0
Command	W0	A3	A2	A1	A0	D10	D9	D8	D7	D6	D5	D4	D3	D2	D1	D0

Table 4. SPI Output Data Response Word Format

	R/W	Data														
Word Bit	B15	B14	B13	B12	B11	B10	B9	B8	B7	B6	B5	B4	B3	B2	B1	B0
Command	F0	A3	A2	A1	A0	D10	D9	D8	D7	D6	D5	D4	D3	D2	D1	D0

SPI Control and Status Registers

Read / Write Bit

The MSB bit of SDI word (W0) is read/write bit. When W0 = 0, input data is a write command; when W0 = 1, input data is a read command, and the register value will send out on the same word cycle from SDO from D10 to D0.

Address Bits

Table 5. Register Address

Register Type	Address [A3..A0]				Register Name	Description	Read and Write Access
Status Register	0	0	0	0	Status Register 1	Report occurred faults after previous reading	R (auto reset to default values after read)
	0	0	0	1	Status Register 2	Device ID and report occurred faults after previous reading	Device ID: R Fault report: R (auto reset to default values after read)
Control Register	0	0	1	0	Control Register 1		R/W
	0	0	1	1	Control Register 2		R/W

SPI Data Bits

Status Registers

Table 6. Status Register 1 (Address: 0x00) (all default values are zero)

Address	Register Name	D10	D9	D8	D7	D6	D5	D4	D3	D2	D1	D0
0x00	Status Register 1	FAULT	GVDD_UV	PVDD_UV	OTSD	OTW	FETHA_OC	FETLA_OC	FETHB_OC	FETLB_OC	FETHC_OC	FETLC_OC

Table 7. Status Register 2 (Address: 0x01) (all default values are zero)

Address	Register Name	D7	D6	D5	D4	D3	D2	D1	D0
0x01	Status Register 2	GVDD_OV				Device ID			
						0	0	0	0

- All status register bits are in latched mode. Read each status register will reset the bits in this register. Read fault register twice to get an updated status condition.
- EN_GATE toggling with “low” level holding longer than 10µs will force a shut down and start up sequence and reset all values in status registers including GVDD_OV fault.
- EN_GATE toggling (quick fault reset) with low level holding less than 10µs or GATE_RESET high (in SPI) will reset all values in status registers except GVDD_OV fault which will still be latched as a fault.

PRODUCT PREVIEW

- **FAULT** is high when any fault occurs to cause a shut down (GVDD_UV, PVDD_UV, OTSD, OCSD, GVDD_OV), which is opposite to $\overline{\text{FAULT}}$ hardware pin.

Control Registers

Table 8. Control Register 1 for Gate Driver Control (Address: 0x02)⁽¹⁾

Address	Name	Description	D10	D9	D8	D7	D6	D5	D4	D3	D2	D1	D0	
0x02	GATE_CURRENT	Gate driver peak current 1.7A (for slew rate control)										0	0	
		Gate driver peak current 0.7A										0	1	
		Gate driver peak current 0.25A										1	0	
		Reserved										1	1	
	GATE_RESET	Normal mode									0			
		Reset all latched faults related to gate driver, reset gate driver back to normal operation, reset status register values to default GATE_RESET value will automatically reset to zero after gate driver completes reset										1		
	PWM_MODE	PWM with six independent inputs									0			
		PWM with three independent inputs. PWM control high side gates only. Low side is complementary to high side gates with minimum internal dead time.									1			
	OC_MODE (gate driver only)	Current limiting when OC detected						0	0					
		Latched shut down when OC detected						0	1					
		Report only (no current limiting or shut down) when OC detected						1	0					
		OC protection disabled (no OC sensing and reporting)						1	1					
	OC_ADJ_SET	See OC_ADJ_SET table	X	X	X	X	X							

(1) **Bold** is default value

Table 9. Control Register 2 for Current Shunt Amplifiers and Misc Control (Address: 0x03)⁽¹⁾

Address	Name	Description	D10	D9	D8	D7	D6	D5	D4	D3	D2	D1	D0
0x03	OCTW_SET	Report both OT and OC at /OCTW pin										0	0
		Report OT only										0	1
		Report OC only										1	0
		Report OC Only (Reserved)										1	1
	GAIN	Gain of shunt amplifier: 10V/V								0	0		
		Gain of shunt amplifier: 20V/V								0	1		
		Gain of shunt amplifier: 40V/V								1	0		
		Gain of shunt amplifier: 80V/V								1	1		
	DC_CAL_CH1	Shunt amplifier 1 connects to load through input pins								0			
		Shunt amplifier 1 shorts input pins and disconnected from load for external calibration								1			
	DC_CAL_CH2	Shunt amplifier 2 connects to load through input pins						0					
		Shunt amplifier 2 shorts input pins and disconnected from load for external calibration							1				
	OC_TOFF	Normal CBC operation (recovering at next PWM cycle)						0					
		Off time control during OC						1					
	Reserved												

(1) **Bold** value is default value

Over Current Adjustment

When external MOSFET is turned on, the output current flows the MOSFET, which creates a voltage drop V_{DS} . The overcurrent protection event will be enabled when the V_{DS} exceeds a pre-set value I_{OC} . The OC tripped value can be programmed through SPI command. Assuming the on resistance of MOSFET is $R_{DS(on)}$, the V_{ds} can be calculated as:

$$V_{DS} = I_{OC} \times R_{DS(on)}$$

V_{DS} is measured across the SL_x and SH_x pins for the low-side MOSFET. For the high-side MOSFET, V_{DS} is measured across PVDD (internally) and SH_x. Therefore, it is important to limit the ripple on the PVDD supply for accurate high-side current sensing.

It is also important to note that there can be up to a 20% tolerance across channels for the OC trip point. This is meant for protection and not to be used for regulating current in a motor phase.

Table 10. OC_ADJ_SET Table

Control Bit (D6–D10) (0xH)	0	1	2	3	4	5	6	7
Vds (V)	0.060	0.068	0.076	0.086	0.097	0.109	0.123	0.138
Control Bit (D6–D10) (0xH)	8	9	10	11	12	13	14	15
Vds (V)	0.155	0.175	0.197	0.222	0.250	0.282	0.317	0.358
Control Bit (D6–D10) (0xH)	16	17	18	19	20	21	22	23
Vds (V)	0.403	0.454	0.511	0.576	0.648	0.730	0.822	0.926
Code Number (0xH)	24	25	26	27	28	29	30	31
Vds (V)	1.043	1.175	1.324	1.491	1.679 ⁽¹⁾	1.892 ⁽¹⁾	2.131 ⁽¹⁾	2.400 ⁽¹⁾

(1) Do not use settings 28, 29, 30, 31 for V_{DS} sensing if the IC is expected to operate in the 6V – 8V range.

Application Schematic Example

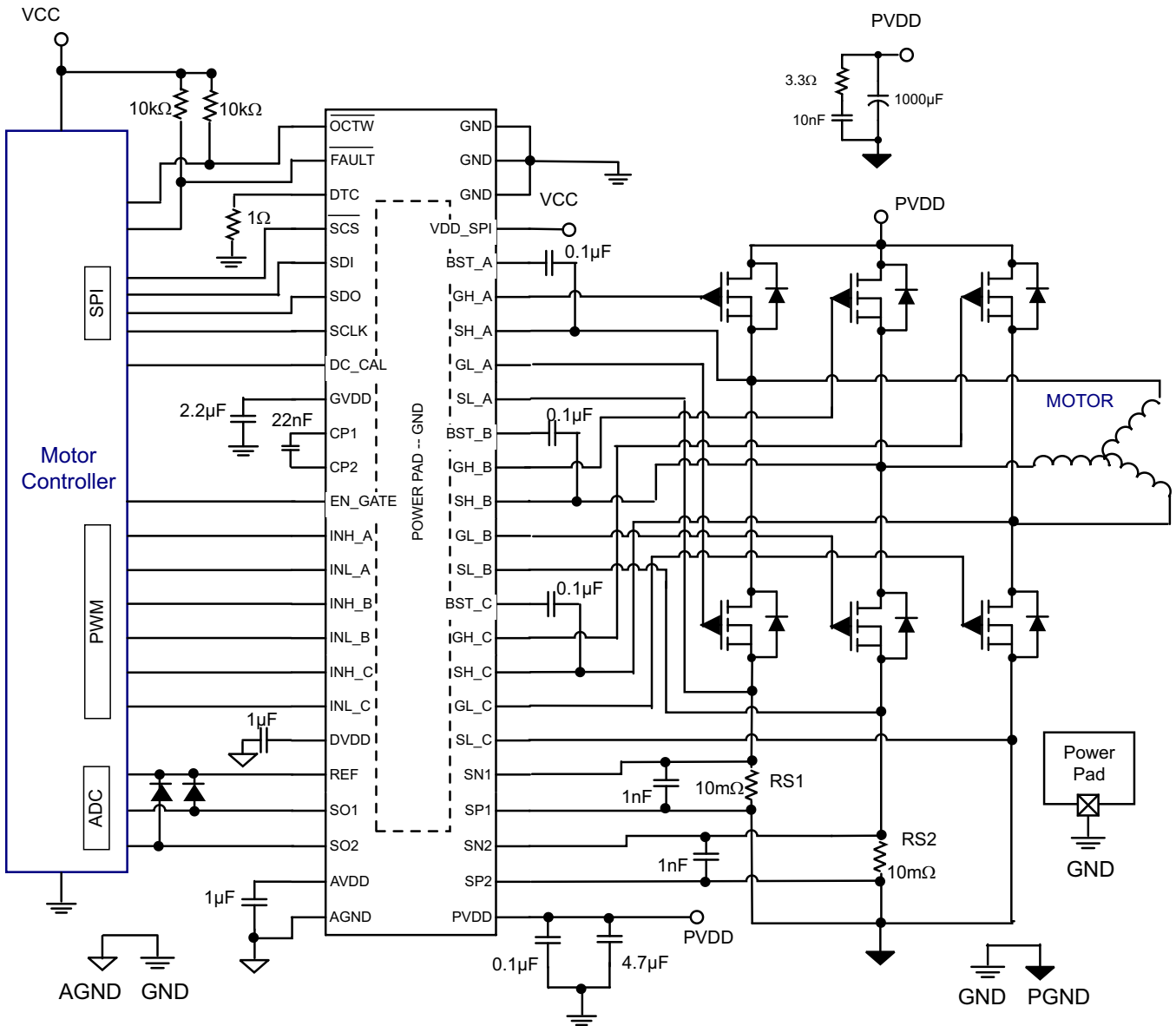

PRODUCT PREVIEW

PCB LAYOUT RECOMMENDATIONS

Below are a few layout recommendations to utilize when designing a PCB for the DRV8303.

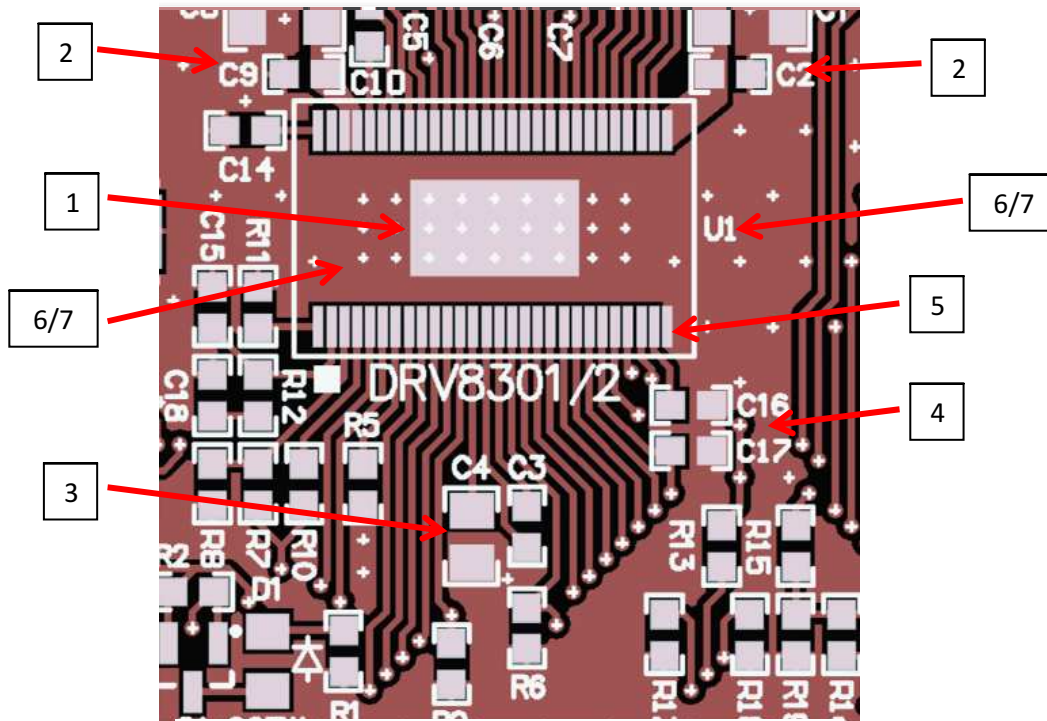

PRODUCT PREVIEW

1. The DRV8303 makes an electrical connection to GND through the PowerPAD. Always check to ensure that the PowerPAD has been properly soldered (See PowerPAD application report, [SLMA002](#)).
2. C1/C2/C8/C9, PVDD decoupling capacitors should be placed close to their corresponding pins with a low impedance path to device GND (PowerPAD).
3. C4, GVDD capacitor should be placed close its corresponding pin with a low impedance path to device GND (PowerPAD).
4. C16/C17, AVDD & DVDD capacitors should be placed close to their corresponding pins with a low impedance path to the AGND pin. It's preferable to make this connection on the same layer.
5. AGND should be tied to device GND (PowerPAD) through a low impedance trace/copper fill.
6. Add stitching vias to reduce the impedance of the GND path from the top to bottom side.
7. Try to clear the space around and underneath the DRV8303 to allow for better heat spreading from the PowerPAD.

Table 11. Recommended Values

DESIGNATOR	PIN	RECOMMENDED VALUE	DESCRIPTION
C1	PVDD1 – pin 29	2.2uF	CAP CER 2.2UF 100V 10% X7R
C2	PVDD1 – pin 29	0.1uF	CAP CER 0.1UF 100V 10% X7R
C8	PVDD2 – pins 53 & 54	2.2uF	CAP CER 2.2UF 100V 10% X7R
C9	PVDD2 – pins 53 & 54	0.1uF	CAP CER 0.1UF 100V 10% X7R
C4	GVDD – pin 13	2.2uF	CAP CER 2.2UF 25V 10% X7R
C16	AVDD – pin 27	1.0uF	CAP CER 1UF 25V 10% X7R
C17	DVDD – pin 23	1.0uF	CAP CER 1UF 25V 10% X7R

PACKAGING INFORMATION

Orderable Device	Status (1)	Package Type	Package Drawing	Pins	Package Qty	Eco Plan (2)	Lead/Ball Finish	MSL Peak Temp (3)	Op Temp (°C)	Device Marking (4/5)	Samples
DRV8303DCA	PREVIEW	HTSSOP	DCA	48	40	Green (RoHS & no Sb/Br)	CU NIPDAU	Level-3-260C-168 HR	-40 to 125		
DRV8303DCAR	PREVIEW	HTSSOP	DCA	48	2000	Green (RoHS & no Sb/Br)	CU NIPDAU	Level-3-260C-168 HR	-40 to 125	DRV8303	

(1) The marketing status values are defined as follows:

ACTIVE: Product device recommended for new designs.

LIFEBUY: TI has announced that the device will be discontinued, and a lifetime-buy period is in effect.

NRND: Not recommended for new designs. Device is in production to support existing customers, but TI does not recommend using this part in a new design.

PREVIEW: Device has been announced but is not in production. Samples may or may not be available.

OBSOLETE: TI has discontinued the production of the device.

(2) Eco Plan - The planned eco-friendly classification: Pb-Free (RoHS), Pb-Free (RoHS Exempt), or Green (RoHS & no Sb/Br) - please check <http://www.ti.com/productcontent> for the latest availability information and additional product content details.

TBD: The Pb-Free/Green conversion plan has not been defined.

Pb-Free (RoHS): TI's terms "Lead-Free" or "Pb-Free" mean semiconductor products that are compatible with the current RoHS requirements for all 6 substances, including the requirement that lead not exceed 0.1% by weight in homogeneous materials. Where designed to be soldered at high temperatures, TI Pb-Free products are suitable for use in specified lead-free processes.

Pb-Free (RoHS Exempt): This component has a RoHS exemption for either 1) lead-based flip-chip solder bumps used between the die and package, or 2) lead-based die adhesive used between the die and leadframe. The component is otherwise considered Pb-Free (RoHS compatible) as defined above.

Green (RoHS & no Sb/Br): TI defines "Green" to mean Pb-Free (RoHS compatible), and free of Bromine (Br) and Antimony (Sb) based flame retardants (Br or Sb do not exceed 0.1% by weight in homogeneous material)

(3) MSL, Peak Temp. -- The Moisture Sensitivity Level rating according to the JEDEC industry standard classifications, and peak solder temperature.

(4) There may be additional marking, which relates to the logo, the lot trace code information, or the environmental category on the device.

(5) Multiple Device Markings will be inside parentheses. Only one Device Marking contained in parentheses and separated by a "~" will appear on a device. If a line is indented then it is a continuation of the previous line and the two combined represent the entire Device Marking for that device.

Important Information and Disclaimer: The information provided on this page represents TI's knowledge and belief as of the date that it is provided. TI bases its knowledge and belief on information provided by third parties, and makes no representation or warranty as to the accuracy of such information. Efforts are underway to better integrate information from third parties. TI has taken and continues to take reasonable steps to provide representative and accurate information but may not have conducted destructive testing or chemical analysis on incoming materials and chemicals. TI and TI suppliers consider certain information to be proprietary, and thus CAS numbers and other limited information may not be available for release.

In no event shall TI's liability arising out of such information exceed the total purchase price of the TI part(s) at issue in this document sold by TI to Customer on an annual basis.

TAPE AND REEL INFORMATION

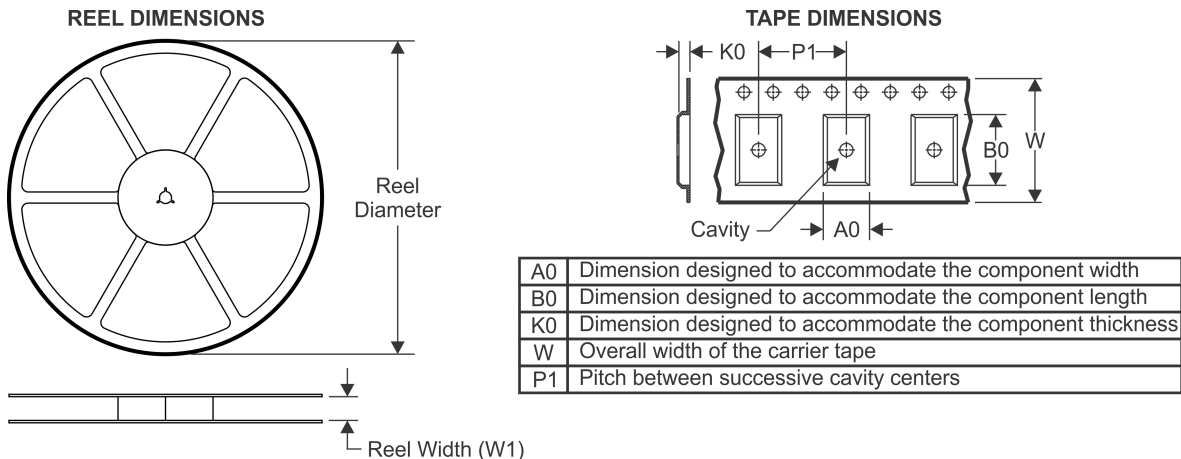

QUADRANT ASSIGNMENTS FOR PIN 1 ORIENTATION IN TAPE



*All dimensions are nominal

Device	Package Type	Package Drawing	Pins	SPQ	Reel Diameter (mm)	Reel Width W1 (mm)	A0 (mm)	B0 (mm)	K0 (mm)	P1 (mm)	W (mm)	Pin1 Quadrant
DRV8303DCAR	HTSSOP	DCA	48	2000	330.0	24.4	8.6	15.8	1.8	12.0	24.0	Q1

TAPE AND REEL BOX DIMENSIONS



*All dimensions are nominal

Device	Package Type	Package Drawing	Pins	SPQ	Length (mm)	Width (mm)	Height (mm)
DRV8303DCAR	HTSSOP	DCA	48	2000	367.0	367.0	45.0

MECHANICAL DATA

DCA (R-PDSO-G48)

PowerPAD™ PLASTIC SMALL-OUTLINE

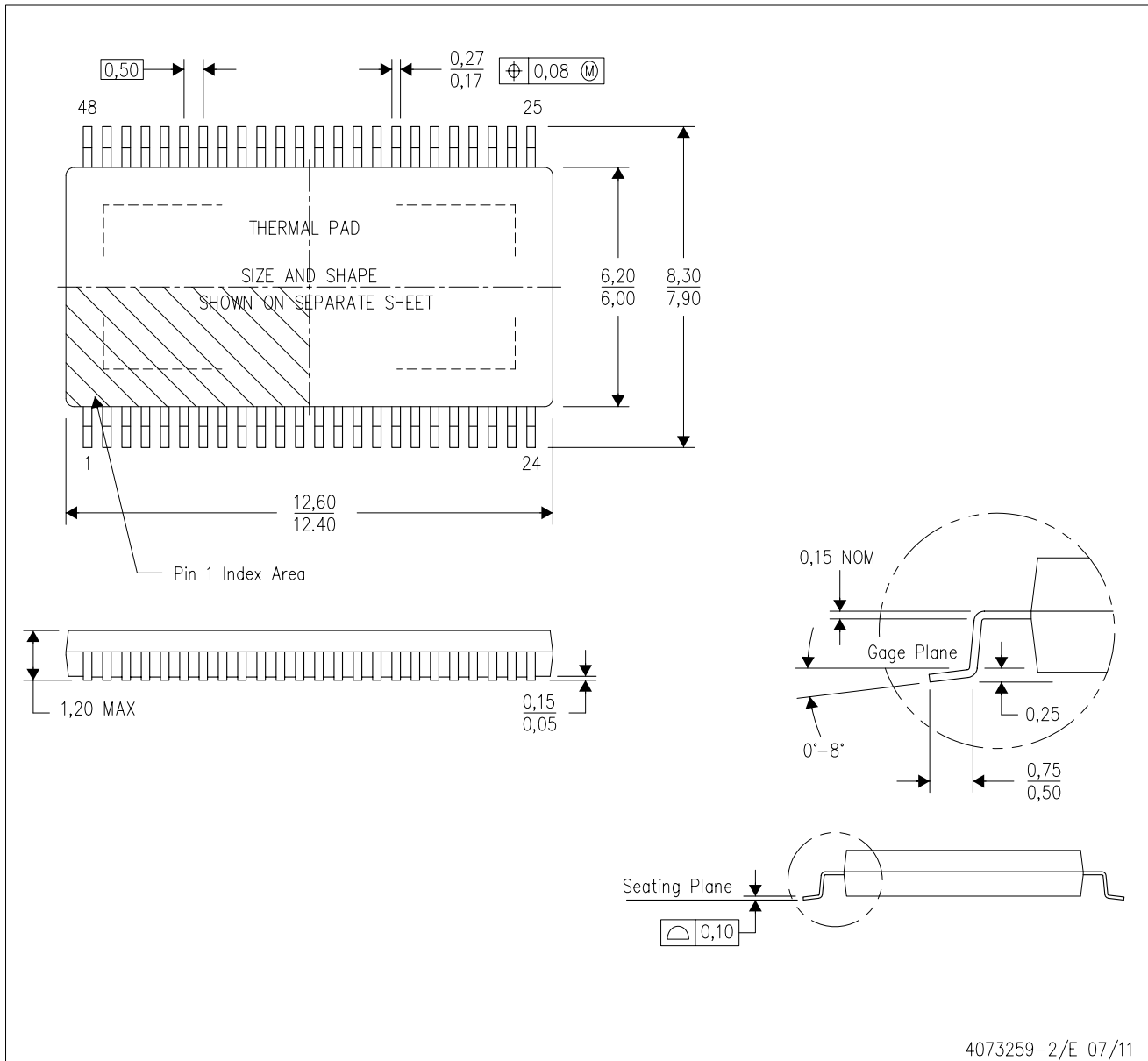

- NOTES:
- All linear dimensions are in millimeters. Dimensioning and tolerancing per ASME Y14.5M-1994.
 - This drawing is subject to change without notice.
 - Body dimensions do not include mold flash or protrusion not to exceed 0,15.
 - This package is designed to be soldered to a thermal pad on the board. Refer to Technical Brief, PowerPad Thermally Enhanced Package, Texas Instruments Literature No. SLMA002 for information regarding recommended board layout. This document is available at www.ti.com <<http://www.ti.com>>.
 - See the additional figure in the Product Data Sheet for details regarding the exposed thermal pad features and dimensions.
 - Falls within JEDEC MO-153

PowerPAD is a trademark of Texas Instruments.

THERMAL PAD MECHANICAL DATA

DCA (R-PDSO-G48)

PowerPAD™ PLASTIC SMALL OUTLINE

THERMAL INFORMATION

This PowerPAD™ package incorporates an exposed thermal pad that is designed to be attached to a printed circuit board (PCB). The thermal pad must be soldered directly to the PCB. After soldering, the PCB can be used as a heatsink. In addition, through the use of thermal vias, the thermal pad can be attached directly to the appropriate copper plane shown in the electrical schematic for the device, or alternatively, can be attached to a special heatsink structure designed into the PCB. This design optimizes the heat transfer from the integrated circuit (IC).

For additional information on the PowerPAD package and how to take advantage of its heat dissipating abilities, refer to Technical Brief, PowerPAD Thermally Enhanced Package, Texas Instruments Literature No. SLMA002 and Application Brief, PowerPAD Made Easy, Texas Instruments Literature No. SLMA004. Both documents are available at www.ti.com.

The exposed thermal pad dimensions for this package are shown in the following illustration.

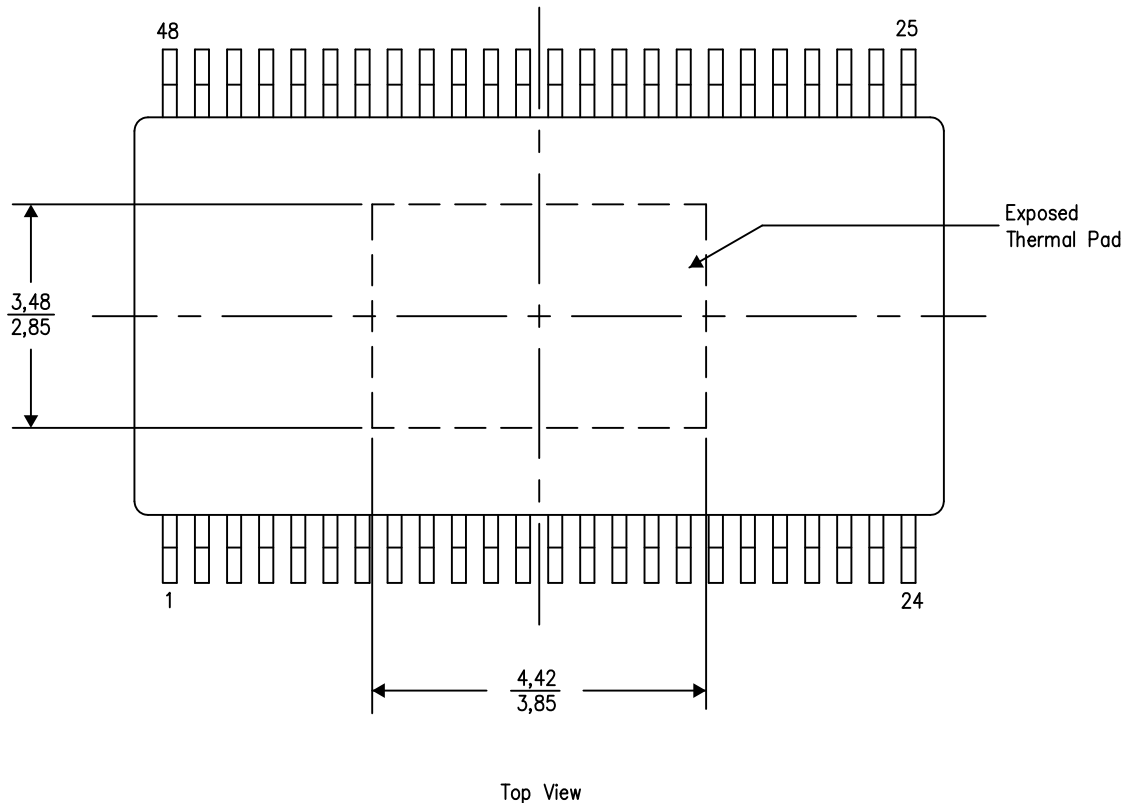

Exposed Thermal Pad Dimensions

4206320-3/R 03/13

NOTE: A. All linear dimensions are in millimeters

PowerPAD is a trademark of Texas Instruments.

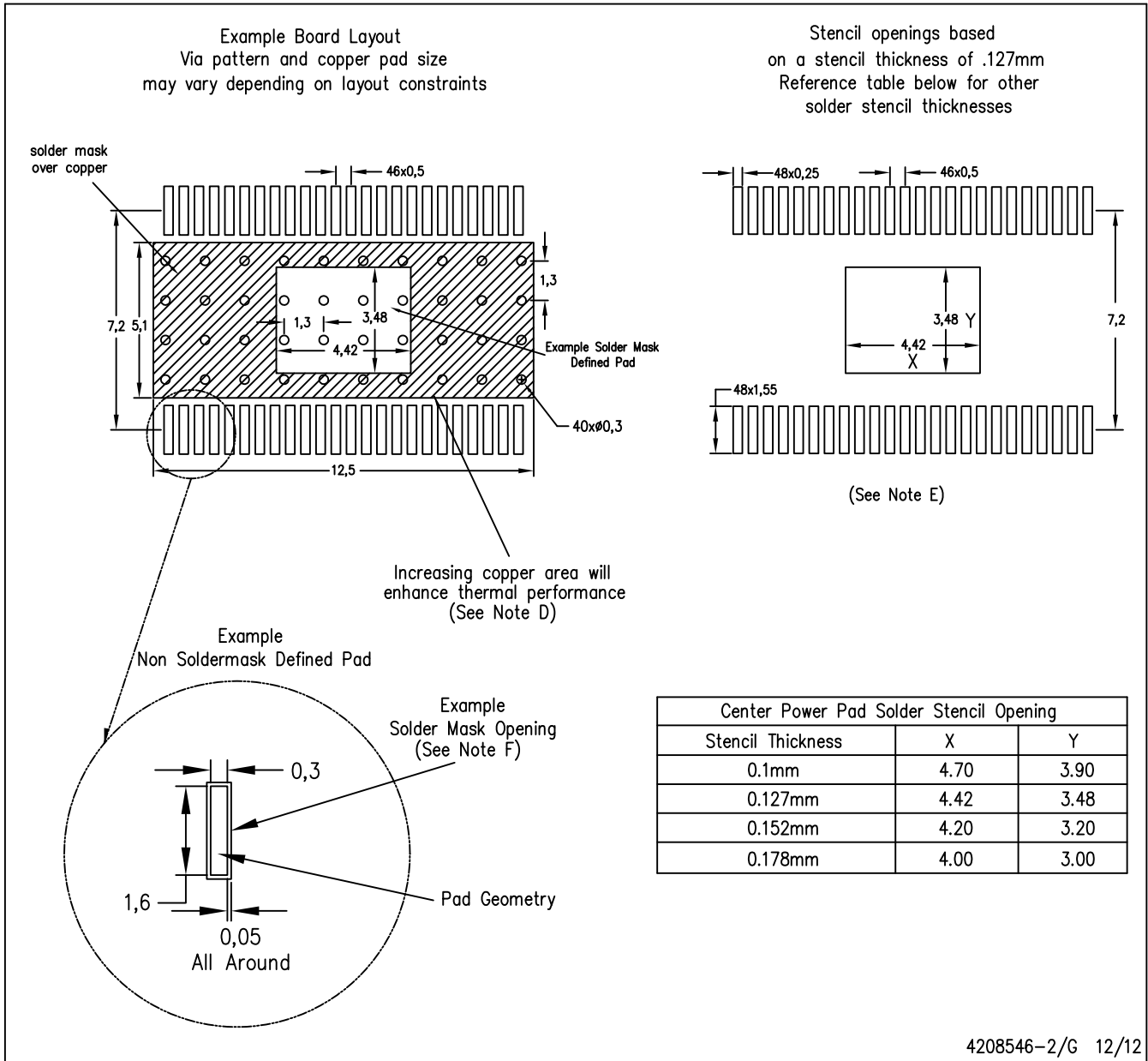

- NOTES:
- A. All linear dimensions are in millimeters.
 - B. This drawing is subject to change without notice.
 - C. Customers should place a note on the circuit board fabrication drawing not to alter the center solder mask defined pad.
 - D. This package is designed to be soldered to a thermal pad on the board. Refer to Technical Brief, PowerPad Thermally Enhanced Package, Texas Instruments Literature No. SLMA002, SLMA004, and also the Product Data Sheets for specific thermal information, via requirements, and recommended board layout. These documents are available at www.ti.com <<http://www.ti.com>>. Publication IPC-7351 is recommended for alternate designs.
 - E. Laser cutting apertures with trapezoidal walls and also rounding corners will offer better paste release. Customers should contact their board assembly site for stencil design recommendations. Example stencil design based on a 50% volumetric metal load solder paste. Refer to IPC-7525 for other stencil recommendations.
 - F. Customers should contact their board fabrication site for solder mask tolerances between and around signal pads.

IMPORTANT NOTICE

Texas Instruments Incorporated and its subsidiaries (TI) reserve the right to make corrections, enhancements, improvements and other changes to its semiconductor products and services per JESD46, latest issue, and to discontinue any product or service per JESD48, latest issue. Buyers should obtain the latest relevant information before placing orders and should verify that such information is current and complete. All semiconductor products (also referred to herein as "components") are sold subject to TI's terms and conditions of sale supplied at the time of order acknowledgment.

TI warrants performance of its components to the specifications applicable at the time of sale, in accordance with the warranty in TI's terms and conditions of sale of semiconductor products. Testing and other quality control techniques are used to the extent TI deems necessary to support this warranty. Except where mandated by applicable law, testing of all parameters of each component is not necessarily performed.

TI assumes no liability for applications assistance or the design of Buyers' products. Buyers are responsible for their products and applications using TI components. To minimize the risks associated with Buyers' products and applications, Buyers should provide adequate design and operating safeguards.

TI does not warrant or represent that any license, either express or implied, is granted under any patent right, copyright, mask work right, or other intellectual property right relating to any combination, machine, or process in which TI components or services are used. Information published by TI regarding third-party products or services does not constitute a license to use such products or services or a warranty or endorsement thereof. Use of such information may require a license from a third party under the patents or other intellectual property of the third party, or a license from TI under the patents or other intellectual property of TI.

Reproduction of significant portions of TI information in TI data books or data sheets is permissible only if reproduction is without alteration and is accompanied by all associated warranties, conditions, limitations, and notices. TI is not responsible or liable for such altered documentation. Information of third parties may be subject to additional restrictions.

Resale of TI components or services with statements different from or beyond the parameters stated by TI for that component or service voids all express and any implied warranties for the associated TI component or service and is an unfair and deceptive business practice. TI is not responsible or liable for any such statements.

Buyer acknowledges and agrees that it is solely responsible for compliance with all legal, regulatory and safety-related requirements concerning its products, and any use of TI components in its applications, notwithstanding any applications-related information or support that may be provided by TI. Buyer represents and agrees that it has all the necessary expertise to create and implement safeguards which anticipate dangerous consequences of failures, monitor failures and their consequences, lessen the likelihood of failures that might cause harm and take appropriate remedial actions. Buyer will fully indemnify TI and its representatives against any damages arising out of the use of any TI components in safety-critical applications.

In some cases, TI components may be promoted specifically to facilitate safety-related applications. With such components, TI's goal is to help enable customers to design and create their own end-product solutions that meet applicable functional safety standards and requirements. Nonetheless, such components are subject to these terms.

No TI components are authorized for use in FDA Class III (or similar life-critical medical equipment) unless authorized officers of the parties have executed a special agreement specifically governing such use.

Only those TI components which TI has specifically designated as military grade or "enhanced plastic" are designed and intended for use in military/aerospace applications or environments. Buyer acknowledges and agrees that any military or aerospace use of TI components which have **not** been so designated is solely at the Buyer's risk, and that Buyer is solely responsible for compliance with all legal and regulatory requirements in connection with such use.

TI has specifically designated certain components as meeting ISO/TS16949 requirements, mainly for automotive use. In any case of use of non-designated products, TI will not be responsible for any failure to meet ISO/TS16949.

Products

Audio	www.ti.com/audio
Amplifiers	amplifier.ti.com
Data Converters	dataconverter.ti.com
DLP® Products	www.dlp.com
DSP	dsp.ti.com
Clocks and Timers	www.ti.com/clocks
Interface	interface.ti.com
Logic	logic.ti.com
Power Mgmt	power.ti.com
Microcontrollers	microcontroller.ti.com
RFID	www.ti-rfid.com
OMAP Applications Processors	www.ti.com/omap
Wireless Connectivity	www.ti.com/wirelessconnectivity

Applications

Automotive and Transportation	www.ti.com/automotive
Communications and Telecom	www.ti.com/communications
Computers and Peripherals	www.ti.com/computers
Consumer Electronics	www.ti.com/consumer-apps
Energy and Lighting	www.ti.com/energy
Industrial	www.ti.com/industrial
Medical	www.ti.com/medical
Security	www.ti.com/security
Space, Avionics and Defense	www.ti.com/space-avionics-defense
Video and Imaging	www.ti.com/video

TI E2E Community

e2e.ti.com