

## 2-Vrms DirectPath™ Line Driver With Programmable-Fixed Gain

 Check for Samples: [DRV612](#)

### FEATURES

- **DirectPath™**
  - Eliminates Pops/Clicks
  - Eliminates Output DC-Blocking Capacitors
  - 3-V to 3.6-V Supply Voltage
- **Low Noise and THD**
  - SNR > 105 dB at  $-1\times$  Gain
  - Typical  $V_n < 12\ \mu\text{Vms}$  20 Hz–20 kHz at  $-1\times$  Gain
  - THD+N < 0.003% at 10-k $\Omega$  Load and  $-1\times$  Gain
- **2-Vrms Output Voltage Into 600- $\Omega$  Load**
- **Single-Ended Input and Output**
- **Programmable Gain Select Reduces Component Count**
  - 13 $\times$  Gain Values
- **Active Mute With More Than 80 dB Attenuation**
- **Short Circuit and Thermal Protection**
- **$\pm 8\text{-kV}$  HBM ESD-Protected Outputs**

### APPLICATIONS

- PDP / LCD TV
- DVD Players
- Mini/Micro Combo Systems
- Soundcards

### DESCRIPTION

The DRV612 is a single-ended, 2-Vrms stereo line driver designed to reduce component count, board space and cost. It is ideal for single-supply electronics where size and cost are critical design parameters.

The DRV612 does not require a power supply greater than 3.3 V to generate its 5.6- $V_{PP}$  output, nor does it require a split-rail power supply.

Designed using TI's patented DirectPath technology, which integrates a charge pump to generate a negative supply rail that provides a clean, pop-free ground-biased output. The DRV612 is capable of driving 2 Vrms into a 600- $\Omega$  load. DirectPath technology also allows the removal of the costly output dc-blocking capacitors.

The device has fixed-gain single-ended inputs with a gain-select pin. Using a single resistor on this pin, the designer can choose from 13 internal programmable gain settings to match the line driver with the codec output level. It also reduces the component count and board space.

Line outputs have  $\pm 8\ \text{kV}$  HBM ESD protection, enabling a simple ESD protection circuit. The DRV612 has built-in active mute control with more than 80 dB attenuation for pop-free mute on/off control.

The DRV612 is available in a 14-pin TSSOP and 16-pin QFN. For a footprint-compatible stereo headphone driver, see TPA6139A2 ([SLOS700](#)).

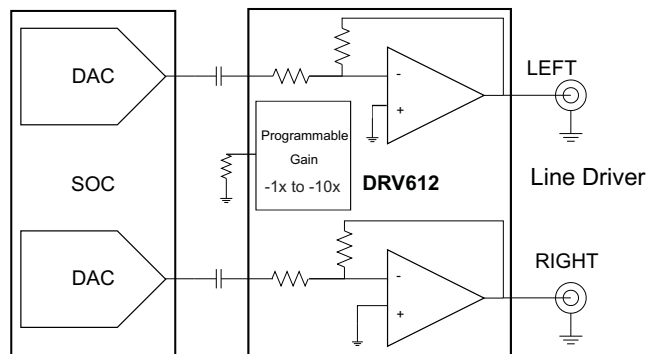

Please be aware that an important notice concerning availability, standard warranty, and use in critical applications of Texas Instruments semiconductor products and disclaimers thereto appears at the end of this data sheet.

DirectPath is a trademark of Texas Instruments.

# DRV612

SLOS690B – DECEMBER 2010 – REVISED APRIL 2011

www.ti.com



These devices have limited built-in ESD protection. The leads should be shorted together or the device placed in conductive foam during storage or handling to prevent electrostatic damage to the MOS gates.

## GENERAL INFORMATION

### TERMINAL ASSIGNMENT

The DRV612 is available in package:

- 14-pin TSSOP package (PW) or 16-pin QFN package (RGT)

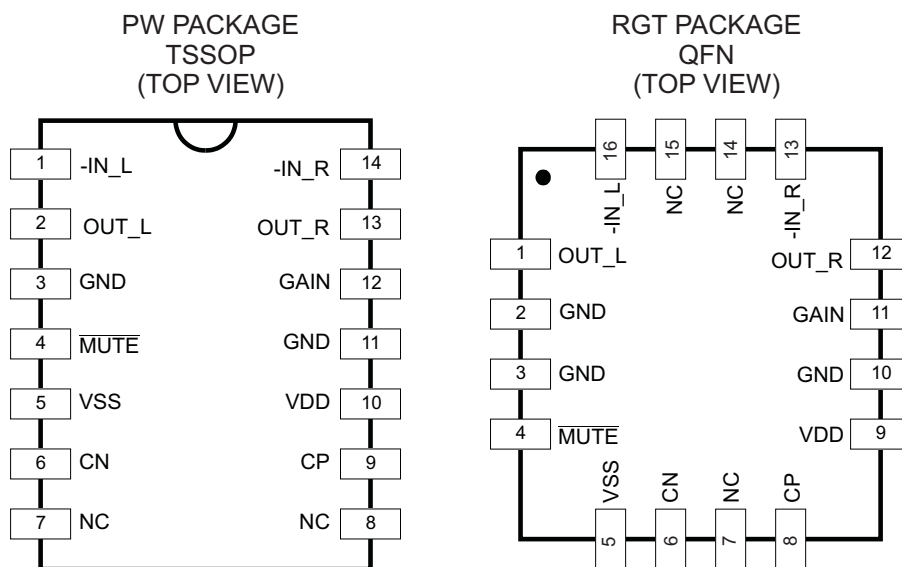

### PIN FUNCTIONS

PIN			FUNCTION <sup>(1)</sup>	DESCRIPTION
NAME	PW NO.	RGT NO.		
-IN_L	1	16	I	Negative input, left channel
OUT_L	2	1	O	Output, left channel
GND	3, 11	2, 3, 10	P	Ground
$\overline{\text{MUTE}}$	4	4	I	MUTE, active low
VSS	5	5	O	Change Pump negative supply voltage
CN	6	6	I/O	Charge Pump flying capacitor negative connection
NC	7, 8	7, 14, 15		No internal connection
CP	9	8	I/O	Charge Pump flying capacitor positive connection
VDD	10	9	P	Supply voltage, connect to positive supply
GAIN	12	11	I	Gain set programming pin; connect a resistor to ground. See <a href="#">Table 1</a> for recommended resistor values
OUT_R	13	12	O	Output, right channel
-IN_R	14	13	I	Negative input, right channel
Thermal Pad	n/a	Thermal Pad	P	Connect to ground

(1) I = input, O = output, P = power

**SYSTEM BLOCK DIAGRAM**

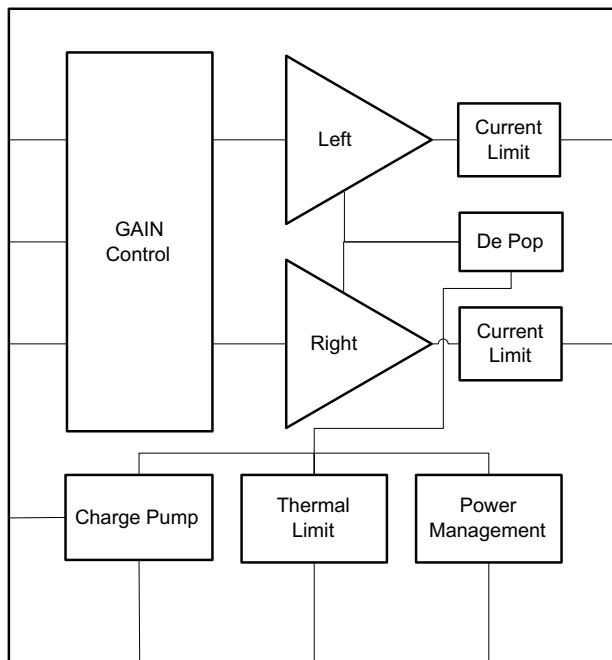

**ORDERING INFORMATION<sup>(1)</sup>**

T <sub>A</sub>	PACKAGE	DESCRIPTION
-40°C to 85°C	DRV612PW	14-pin TSSOP
	DRV612RGT	16-pin QFN

(1) For the most current package and ordering information, see the Package Option Addendum at the end of this document, or see the TI Web site at [www.ti.com](http://www.ti.com).

**THERMAL INFORMATION**

THERMAL METRIC <sup>(1)</sup>		DRV612	DRV612	UNITS
		RGT (16-Pin)	PW (14-Pin)	
$\theta_{JA}$	Junction-to-ambient thermal resistance	52	130	°C/W
$\theta_{JcTop}$	Junction-to-case (top) thermal resistance	71	49	
$\theta_{JB}$	Junction-to-board thermal resistance	26	63	
$\Psi_{JT}$	Junction-to-top characterization parameter	3.0	3.6	
$\Psi_{JB}$	Junction-to-board characterization parameter	26	62	
$\theta_{JcBot}$	Junction-to-case (bottom) thermal resistance	n/a	n/a	

(1) For more information about traditional and new thermal metrics, see the *IC Package Thermal Metrics* application report, [SPRA953](http://www.ti.com/lit/zip/spra953).

# DRV612

SLOS690B – DECEMBER 2010 – REVISED APRIL 2011

[www.ti.com](http://www.ti.com)

## ABSOLUTE MAXIMUM RATINGS<sup>(1)</sup>

over operating free-air temperature range (unless otherwise noted)

		VALUE		UNIT
		MIN	MAX	
Voltage range	VDD to GND	–0.3	4	V
	V <sub>I</sub> , Input voltage	VSS – 0.3	VDD + 0.3	
	$\overline{\text{MUTE}}$ to GND	–0.3	VDD + 0.3	
Temperature	Maximum operating junction temperature range, T <sub>J</sub>	–40	150	°C
	Storage temperature	–65	150	
Electrostatic discharge (HBM) QSS 009-105 (JESD22-A114A)		OUT_L, OUT_R	8	kV
		All other pins	2	

(1) Stresses beyond those listed under *Absolute Maximum Ratings* may cause permanent damage to the device. These are stress ratings only, and functional operation of the device at these or any other conditions beyond those indicated under *Recommended Operating Conditions* is not implied. Exposure to absolute-maximum-rated conditions for extended periods may affect device reliability.

## RECOMMENDED OPERATING CONDITIONS

over operating free-air temperature range unless otherwise noted

		MIN	NOM	MAX	UNIT		
VDD	Supply voltage	DC supply voltage		3.0	3.3	3.6	V
R <sub>L</sub>		600	10k				Ω
V <sub>IL</sub>	Low-level input voltage	$\overline{\text{MUTE}}$		38	40	43	%VDD
V <sub>IH</sub>	High-level input voltage	$\overline{\text{MUTE}}$		57	60	66	%VDD
T <sub>A</sub>	Free-air temperature	–0	25	85			°C

## ELECTRICAL CHARACTERISTICS

VDD = 3.3V, R<sub>LD</sub> = 5 kΩ, T<sub>A</sub> = 25°C, Charge pump: C<sub>CP</sub> = 1 μF, unless otherwise noted.

PARAMETER		TEST CONDITIONS	MIN	TYP	MAX	UNIT
V <sub>OS</sub>	Output offset voltage	VDD = 3.3 V, input ac-coupled		0.5	1	mV
PSRR	Power-supply rejection ratio		70	80		dB
V <sub>OH</sub>	High-level output voltage	VDD = 3.3 V	3.1			V
V <sub>OL</sub>	Low-level output voltage	VDD = 3.3 V			-3.05	V
V <sub>uvp_on</sub>	VDD, undervoltage detection				2.8	V
V <sub>uvp_hysteresis</sub>	VDD, undervoltage detection, hysteresis			200		mV
F <sub>CP</sub>	Charge-pump switching frequency			350		kHz
I <sub>IH</sub>	High-level input current, $\overline{\text{MUTE}}$	VDD = 3.3 V, V <sub>IH</sub> = VDD			1	μA
I <sub>IL</sub>	Low-level input current, $\overline{\text{MUTE}}$	VDD = 3.3 V, V <sub>IL</sub> = 0 V			1	μA
I <sub>(VDD)</sub>	Supply current, no load	VDD, $\overline{\text{MUTE}} = 3.3 \text{ V}$		18		mA
	Supply current, MUTED	VDD = 3.3 V, $\overline{\text{MUTE}} = \text{GND}$		18		mA
T <sub>SD</sub>	Thermal shutdown			150		°C
	Thermal shutdown hysteresis			15		°C

## ELECTRICAL CHARACTERISTICS, LINE DRIVER

VDD = 3.3 V, R<sub>LOAD</sub> = 10 kΩ, T<sub>A</sub> = 25°C, Charge pump: C<sub>CP</sub> = 1 μF, 1× gain select (unless otherwise noted)

PARAMETER		TEST CONDITIONS	MIN	TYP	MAX	UNIT
V <sub>O</sub>	Output voltage, outputs in phase	1% THD+N, f = 1 kHz, 10 -kΩ load		2.2		V <sub>rms</sub>
THD+N	Total harmonic distortion plus noise	f = 1 kHz, 10-kΩ load, V <sub>O</sub> = 2 V <sub>rms</sub>		0.007%		
SNR	Signal-to-noise ratio	A-weighted, AES17 filter, 2 V <sub>rms</sub> ref		105		dB
DNR	Dynamic range	A-weighted, AES17 filter, 2 V <sub>rms</sub> ref		105		dB
V <sub>n</sub>	Noise voltage	A-weighted, AES17 filter		12		μV
Z <sub>o</sub>	Output impedance when muted	$\overline{\text{MUTE}} = \text{GND}$		0.07	1	Ω
	Input-to-output attenuation when muted	1 V <sub>rms</sub> , 1-kHz input		80		dB
	Slew rate			4.5		V/μs
G <sub>BW</sub>	Unity-gain bandwidth			8		MHz
	Crosstalk – Line L-R and R-L	10-kΩ load, V <sub>O</sub> = 2 V <sub>rms</sub>		-91		dB
I <sub>limit</sub>	Current limit	VDD = 3.3 V		25		mA

# DRV612

SLOS690B – DECEMBER 2010 – REVISED APRIL 2011

[www.ti.com](http://www.ti.com)

## PROGRAMMABLE GAIN SETTINGS<sup>(1)(2)</sup>

VDD = 3.3 V, R<sub>load</sub> = 10 kΩ, T<sub>A</sub> = 25°C, Charge pump: C<sub>CP</sub> = 1 μF, 1× gain select, unless otherwise noted

PARAMETER	TEST CONDITIONS	MIN	TYP	MAX	UNIT
R_Tol	Gain programming resistor tolerance			2%	
ΔA <sub>V</sub>	Gain matching	Between left and right channels		0.25	dB
	Gain step tolerance		0.1		dB
Gain steps	Gain resistor 2% tolerance				V/V
	249k or higher		-2		
	82k5		-1		
	51k1		-1.5		
	34k8		-2.3		
	27k4		-2.5		
	20k5		-3		
	15k4		-3.5		
	11k5		-4		
	9k09		-5		
	7k50		-5.6		
	6k19		-6.4		
5k11		-8.3			
4k22		-10			
Input impedance	Gain resistor 2% tolerance				kΩ
	249k or higher		37		
	82k5		55		
	51k1		44		
	34k8		33		
	27k4		31		
	20k5		28		
	15k4		24		
	11k5		22		
	9k09		18		
	7k50		17		
	6k19		15		
5k11		12			
4k22		10			

- (1) If the GAIN pin is left floating, an internal pullup sets the gain to -2×.
- (2) Gain setting is latched during power up.

**TYPICAL CHARACTERISTICS, LINE DRIVER**

$V_{DD} = 3.3\text{ V}$ ,  $T_A = 25^\circ\text{C}$ ,  $R_L = 2.5\text{ k}\Omega$ ,  $C_{PUMP} = C_{(VSS)} = 1\ \mu\text{F}$ , Gain =  $-2\text{V/V}$  (unless otherwise noted)

**THD+N vs OUTPUT VOLTAGE**  
3.3 V, 10 k $\Omega$ , 1 kHz

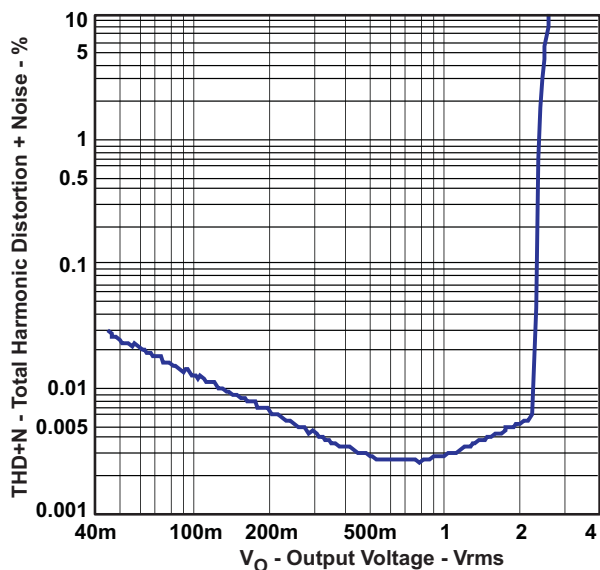

Figure 1.

**THD+N vs OUTPUT VOLTAGE**  
3.3 V, 600  $\Omega$  load, 1 kHz

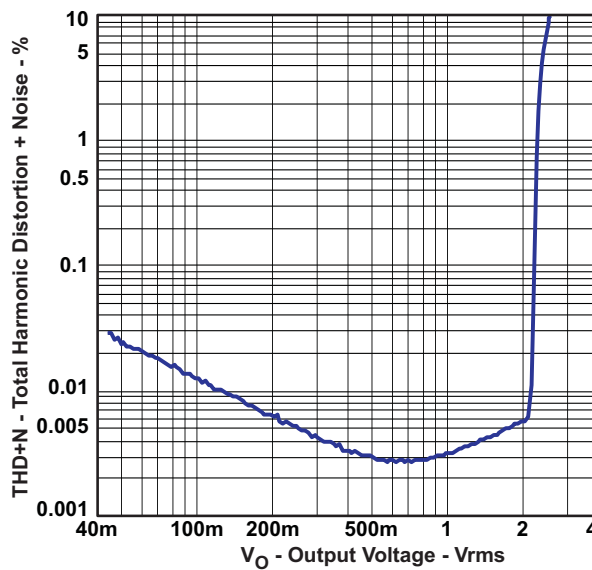

Figure 2.

**THD+N vs FREQUENCY**  
3.3 V, 10 k $\Omega$  load, 2 Vrms

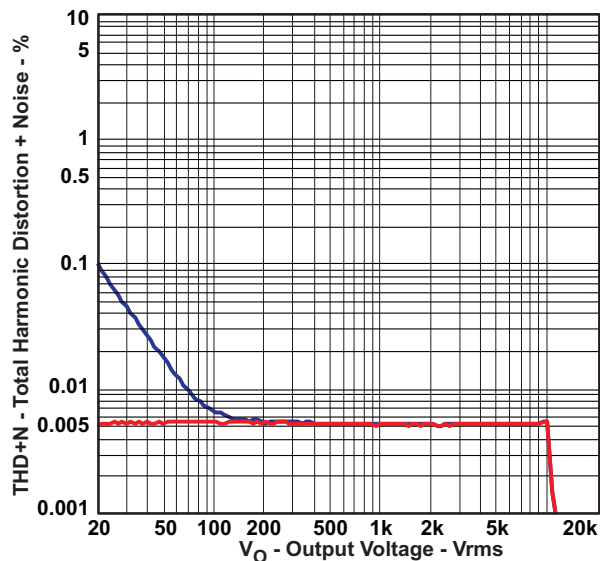

Figure 3.

**CHANNEL SEPARATION**  
3.3 V, 5 k $\Omega$  load, 2 Vrms, Blue L to R, Red R to L

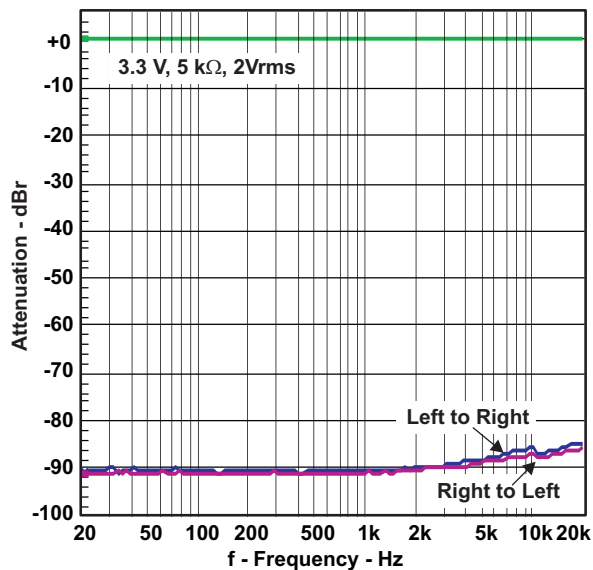

Figure 4.

Blue: 10- $\mu\text{F}$  ceramic ac-coupling capacitor.  
Red: 10- $\mu\text{F}$  electrolytic ac-coupling capacitor

**TYPICAL CHARACTERISTICS, LINE DRIVER (continued)**

$V_{DD} = 3.3\text{ V}$ ,  $T_A = 25^\circ\text{C}$ ,  $R_L = 2.5\text{ k}\Omega$ ,  $C_{PUMP} = C_{(VSS)} = 1\ \mu\text{F}$ , Gain =  $-2V/V$  (unless otherwise noted)

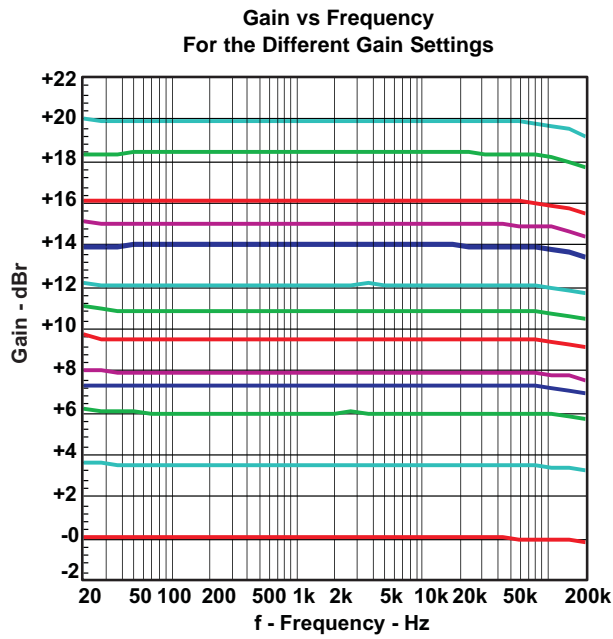

Figure 5.

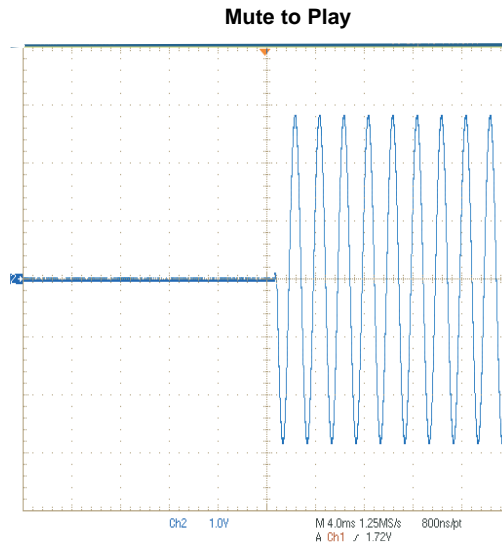

Figure 6.

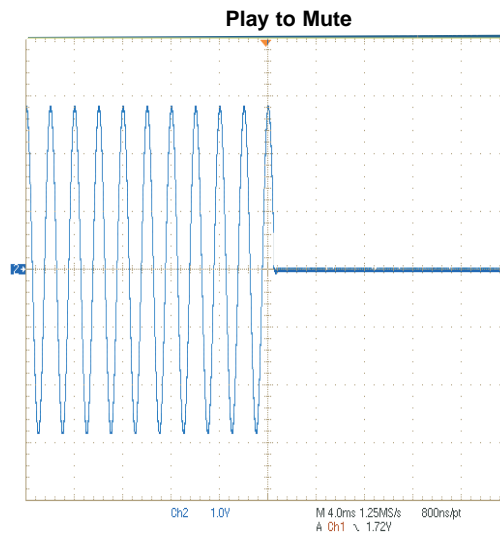

Figure 7.

## APPLICATION INFORMATION

### LINE DRIVER AMPLIFIERS

Single-supply line-driver amplifiers typically require dc-blocking capacitors. The top drawing in [Figure 8](#) illustrates the conventional line-driver amplifier connection to the load and output signal.

DC blocking capacitors are often large in value, and a mute circuit is needed during power up to minimize click and pop. The output capacitor and mute circuit consume PCB area and increase cost of assembly, and can reduce the fidelity of the audio output signal.

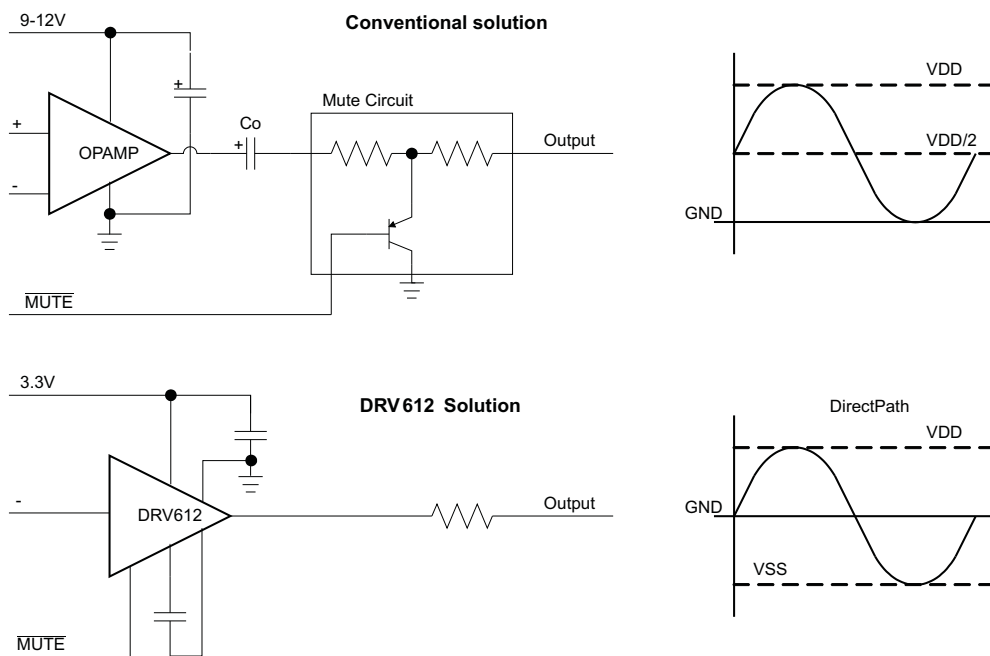

**Figure 8. Conventional and DirectPath Line Driver**

The DirectPath amplifier architecture operates from a single supply but makes use of an internal charge pump to provide a negative voltage rail.

Combining the user-provided positive rail and the negative rail generated by the IC, the device operates in what is effectively a split supply mode.

The output voltages are now centered at zero volts with the capability to swing to the positive rail or negative rail. Combining this with the built-in click- and pop-reduction circuit, the DirectPath amplifier requires no output dc-blocking capacitors.

The bottom block diagram and waveform of [Figure 8](#) illustrate the ground-referenced line-driver architecture. This is the architecture of the DRV612.

## COMPONENT SELECTION

### Charge Pump Flying Capacitor and VSS Capacitor

The charge-pump flying capacitor serves to transfer charge during the generation of the negative supply voltage. The VSS capacitor must be at least equal to the charge pump capacitor in order to allow maximum charge transfer. Low-ESR capacitors are an ideal selection, and a value of 1  $\mu\text{F}$  is typical.

### Decoupling Capacitors

The DRV612 is a DirectPath line-driver amplifier that requires adequate power-supply decoupling to ensure that the noise and total harmonic distortion (THD) are low. A good low equivalent-series-resistance (ESR) ceramic capacitor, typically 1  $\mu\text{F}$ , placed as close as possible to the device VDD lead works best. Placing this decoupling capacitor close to the DRV612 is important for the performance of the amplifier. For filtering lower-frequency noise signals, a 10- $\mu\text{F}$  or greater capacitor placed near the audio power amplifier also helps, but it is not required in most applications because of the high PSRR of this device.

### Gain-Setting

The gain setting is programmed with the GAIN pin. Gain setting is latched during power on. [Table 1](#) lists the gain settings.

NOTE: If gain pin is left unconnected (open) default gain of  $-2\times$  is selected.

**Table 1. Gain Settings**

Gain_set RESISTOR	GAIN	GAIN (dB)	INPUT RESISTANCE
249 k $\Omega$ <sup>(1)</sup>	$-2\times$	6	37 k $\Omega$
82k5	$-1\times$	0.0	55 k $\Omega$
51k1	$-1.5\times$	3.5	44 k $\Omega$
34k8	$-2.3\times$	7.2	33 k $\Omega$
27k4	$-2.5\times$	8	31 k $\Omega$
20k5	$-3\times$	9.5	28 k $\Omega$
15k4	$-3.5\times$	10.9	24 k $\Omega$
11k5	$-4.0\times$	12	22 k $\Omega$
9k09	$-5\times$	14	18 k $\Omega$
7k5	$-5.6\times$	15	17 k $\Omega$
6k19	$-6.4\times$	16.1	15 k $\Omega$
5k11	$-8.3\times$	18.4	12 k $\Omega$
4k22	$-10\times$	20	10 k $\Omega$

(1) or higher

### Internal Undervoltage Detection

The DRV612 contains an internal precision band-gap reference voltage and a comparator used to monitor the supply voltage, VDD. The internal VDD monitor is set at 2.8 V with 200-mV hysteresis.

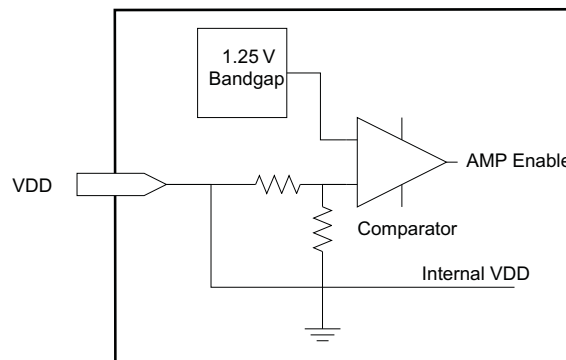

## Input-Blocking Capacitors

DC input-blocking capacitors are required to be added in series with the audio signal into the input pins of the DRV612. These capacitors block the dc portion of the audio source and allow the DRV612 inputs to be properly biased to provide maximum performance. The input blocking capacitors also limit the dc gain to 1, limiting the dc-offset voltage at the output.

These capacitors form a high-pass filter with the input resistor,  $R_{IN}$ . The cutoff frequency is calculated using Equation 1. For this calculation, the capacitance used is the input-blocking capacitor and the resistance is the input resistor chosen from Table 2. Then the frequency and/or capacitance can be determined when one of the two values is given.

$$f_{C_{IN}} = \frac{1}{2\pi R_{IN} C_{IN}} \quad \text{or} \quad C_{IN} = \frac{1}{2\pi f_{C_{IN}} R_{IN}} \quad (1)$$

For a fixed cutoff frequency of 2 Hz, the size of the input capacitance is shown in Table 2 with the capacitors rounded up to nearest E6 values. For 20-Hz cutoff, simply divide the capacitor values with 10; e.g., for 1× gain, 150 nF is needed.

**Table 2. Input Capacitor for Different Gain and Cutoff**

Gain_set RESISTOR	GAIN	Gain (dB)	INPUT RESISTANCE	2 Hz Cutoff
249 kΩ	-2 ×	6	37 kΩ	2.2 μF
82k5	-1 ×	0.0	55 kΩ	1.5 μF
51k1	-1.5×	3.5	44 kΩ	2.2 μF
34k8	-2.3×	7.2	33 kΩ	3.3 μF
27k4	-2.5×	8	31 kΩ	3.3 μF
20k5	-3×	9.5	28 kΩ	3.3 μF
15k4	-3.5×	10.9	24 kΩ	3.3 μF
11k5	-4×	12	22 kΩ	4.7 μF
9k09	-5×	14	18 kΩ	4.7 μF
7k5	-5.6×	15	17 kΩ	4.7 μF
6k19	-6.4×	16.1	15 kΩ	6.8 μF
5k11	-8.3×	18.4	12 kΩ	6.8 μF
4k22	-10×	20	10 kΩ	10 μF

## Pop-Free Power Up

Pop-free power up is ensured by keeping the  $\overline{\text{MUTE}}$  pin low during power-supply ramp-up and -down. The pins should be kept low until the input ac-coupling capacitors are fully charged before asserting the  $\overline{\text{MUTE}}$  pin high, this way proper pre-charge of the ac-coupling is performed and pop-less power up is achieved. Figure 9 illustrates the preferred sequence.

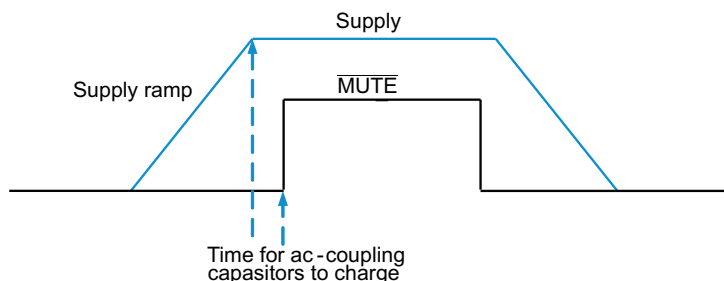

**Figure 9. Power-Up/Down Sequence**

## DRV612

SLOS690B – DECEMBER 2010 – REVISED APRIL 2011

[www.ti.com](http://www.ti.com)

### CAPACITIVE LOAD

The DRV612 has the ability to drive a high capacitive load up to 220 pF directly. Higher capacitive loads can be accepted by adding a series resistor of 47  $\Omega$  or larger for the line driver output.

### LAYOUT RECOMMENDATIONS

A proposed layout for the DRV612 can be seen in the DRV612EVM User's Guide ([SLOU248](#)), and the Gerber files can be downloaded from <http://focus.ti.com/docs/toolsw/folders/print/DRV612evm.html>. To access this information, open the DRV612 product folder and look in the Tools and Software folder.

Ground traces are recommended to be routed as a star ground to minimize hum interference. VDD, VSS decoupling capacitors and the charge-pump capacitors should be connected with short traces.

**FOOTPRINT COMPATIBLE WITH TPA6139A2**

The DRV612 stereo line driver is pin compatible with the headphone amplifier TPA6139A2. Therefore, a single PCB layout can be used with stuffing options for different board configurations.

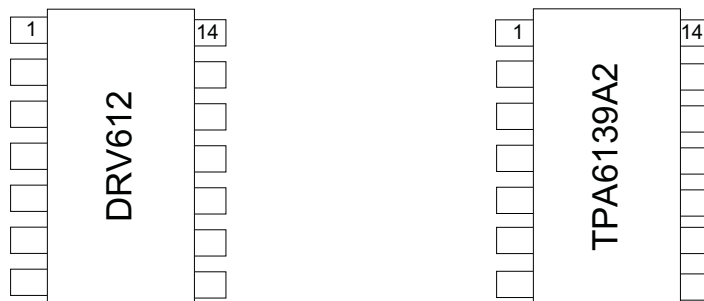

**APPLICATION CIRCUIT**

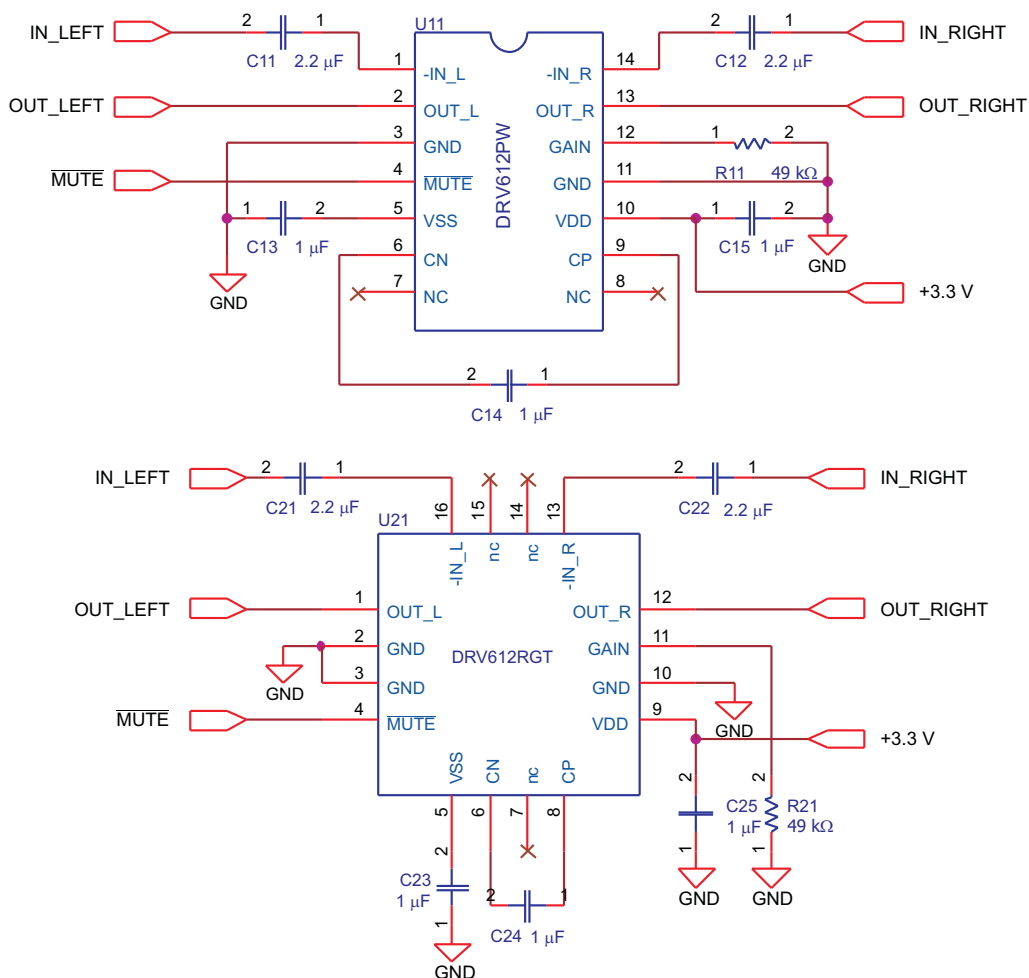

**Figure 10. Single-Ended Input and Output, Gain Set to  $-1.5\times$**

## REVISION HISTORY

<b>Changes from Original (December 2010) to Revision A</b>	<b>Page</b>
• Added the QFN pinout drawing .....	2
• Added the QFN device To the PIN FUNCTIONS table .....	2
• Changed the Abs Max Storage Temp From: MIN = -40 To: MIN = -65 .....	4
• Changed the Gain resistor 2% tolerance values in the Programmable Gain Settings table For Gain Steps and Input Impedance .....	6
• Changed Note 1 of the PROGRAMMABLE GAIN SETTINGS table From: If pin 12, GAIN, is left floating To: If the GAIN pin is left floating .....	6
• Changed From: $C_{PUMP} = C_{(VSS)} = 10 \mu F$ To: $C_{PUMP} = C_{(VSS)} = 1 \mu F$ in the Typical Characteristics condition text .....	7
• Changed the Gain_set RESISTOR values in <a href="#">Table 1</a> .....	10
• Changed the Gain_set RESISTOR values in <a href="#">Table 2</a> .....	11
• Removed references to DRV614 from the FOOTPRINT COMPATIBLE WITH TPA6139A2 section .....	13
 <b>Changes from Revision A (February 2011) to Revision B</b>	 <b>Page</b>
• Deleted the Product Preview note from the RGT package .....	3
• Changed $R_{IN} = 10 \text{ k}\Omega$ , $R_{fb} = 20 \text{ k}\Omega$ To Gain = -2V/V in the Typical Characteristics condition text .....	7

**PACKAGING INFORMATION**

Orderable Device	Status <sup>(1)</sup>	Package Type	Package Drawing	Pins	Package Qty	Eco Plan <sup>(2)</sup>	Lead/ Ball Finish	MSL Peak Temp <sup>(3)</sup>	Samples (Requires Login)
DRV612PW	ACTIVE	TSSOP	PW	14	90	Green (RoHS & no Sb/Br)	CU NIPDAU	Level-2-260C-1 YEAR	
DRV612PWR	ACTIVE	TSSOP	PW	14	2000	Green (RoHS & no Sb/Br)	CU NIPDAU	Level-2-260C-1 YEAR	
DRV612RGTR	ACTIVE	QFN	RGT	16	3000	Green (RoHS & no Sb/Br)	CU NIPDAU	Level-2-260C-1 YEAR	
DRV612RGTT	ACTIVE	QFN	RGT	16	250	Green (RoHS & no Sb/Br)	CU NIPDAU	Level-2-260C-1 YEAR	

<sup>(1)</sup> The marketing status values are defined as follows:

**ACTIVE:** Product device recommended for new designs.

**LIFEBUY:** TI has announced that the device will be discontinued, and a lifetime-buy period is in effect.

**NRND:** Not recommended for new designs. Device is in production to support existing customers, but TI does not recommend using this part in a new design.

**PREVIEW:** Device has been announced but is not in production. Samples may or may not be available.

**OBSELETE:** TI has discontinued the production of the device.

<sup>(2)</sup> Eco Plan - The planned eco-friendly classification: Pb-Free (RoHS), Pb-Free (RoHS Exempt), or Green (RoHS & no Sb/Br) - please check <http://www.ti.com/productcontent> for the latest availability information and additional product content details.

**TBD:** The Pb-Free/Green conversion plan has not been defined.

**Pb-Free (RoHS):** TI's terms "Lead-Free" or "Pb-Free" mean semiconductor products that are compatible with the current RoHS requirements for all 6 substances, including the requirement that lead not exceed 0.1% by weight in homogeneous materials. Where designed to be soldered at high temperatures, TI Pb-Free products are suitable for use in specified lead-free processes.

**Pb-Free (RoHS Exempt):** This component has a RoHS exemption for either 1) lead-based flip-chip solder bumps used between the die and package, or 2) lead-based die adhesive used between the die and leadframe. The component is otherwise considered Pb-Free (RoHS compatible) as defined above.

**Green (RoHS & no Sb/Br):** TI defines "Green" to mean Pb-Free (RoHS compatible), and free of Bromine (Br) and Antimony (Sb) based flame retardants (Br or Sb do not exceed 0.1% by weight in homogeneous material)

<sup>(3)</sup> MSL, Peak Temp. -- The Moisture Sensitivity Level rating according to the JEDEC industry standard classifications, and peak solder temperature.

**Important Information and Disclaimer:** The information provided on this page represents TI's knowledge and belief as of the date that it is provided. TI bases its knowledge and belief on information provided by third parties, and makes no representation or warranty as to the accuracy of such information. Efforts are underway to better integrate information from third parties. TI has taken and continues to take reasonable steps to provide representative and accurate information but may not have conducted destructive testing or chemical analysis on incoming materials and chemicals. TI and TI suppliers consider certain information to be proprietary, and thus CAS numbers and other limited information may not be available for release.

In no event shall TI's liability arising out of such information exceed the total purchase price of the TI part(s) at issue in this document sold by TI to Customer on an annual basis.

**TAPE AND REEL INFORMATION**

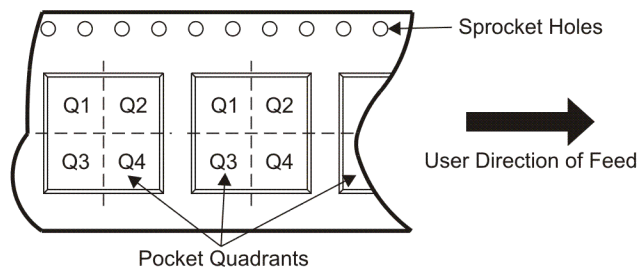
**QUADRANT ASSIGNMENTS FOR PIN 1 ORIENTATION IN TAPE**

\*All dimensions are nominal

Device	Package Type	Package Drawing	Pins	SPQ	Reel Diameter (mm)	Reel Width W1 (mm)	A0 (mm)	B0 (mm)	K0 (mm)	P1 (mm)	W (mm)	Pin1 Quadrant
DRV612PWR	TSSOP	PW	14	2000	330.0	12.4	6.9	5.6	1.6	8.0	12.0	Q1
DRV612RGTR	QFN	RGT	16	3000	330.0	12.4	3.3	3.3	1.1	8.0	12.0	Q2
DRV612RGTT	QFN	RGT	16	250	180.0	12.4	3.3	3.3	1.1	8.0	12.0	Q2

**TAPE AND REEL BOX DIMENSIONS**

\*All dimensions are nominal

Device	Package Type	Package Drawing	Pins	SPQ	Length (mm)	Width (mm)	Height (mm)
DRV612PWR	TSSOP	PW	14	2000	346.0	346.0	29.0
DRV612RGTR	QFN	RGT	16	3000	346.0	346.0	29.0
DRV612RGTT	QFN	RGT	16	250	190.5	212.7	31.8

PW (R-PDSO-G14)

PLASTIC SMALL OUTLINE

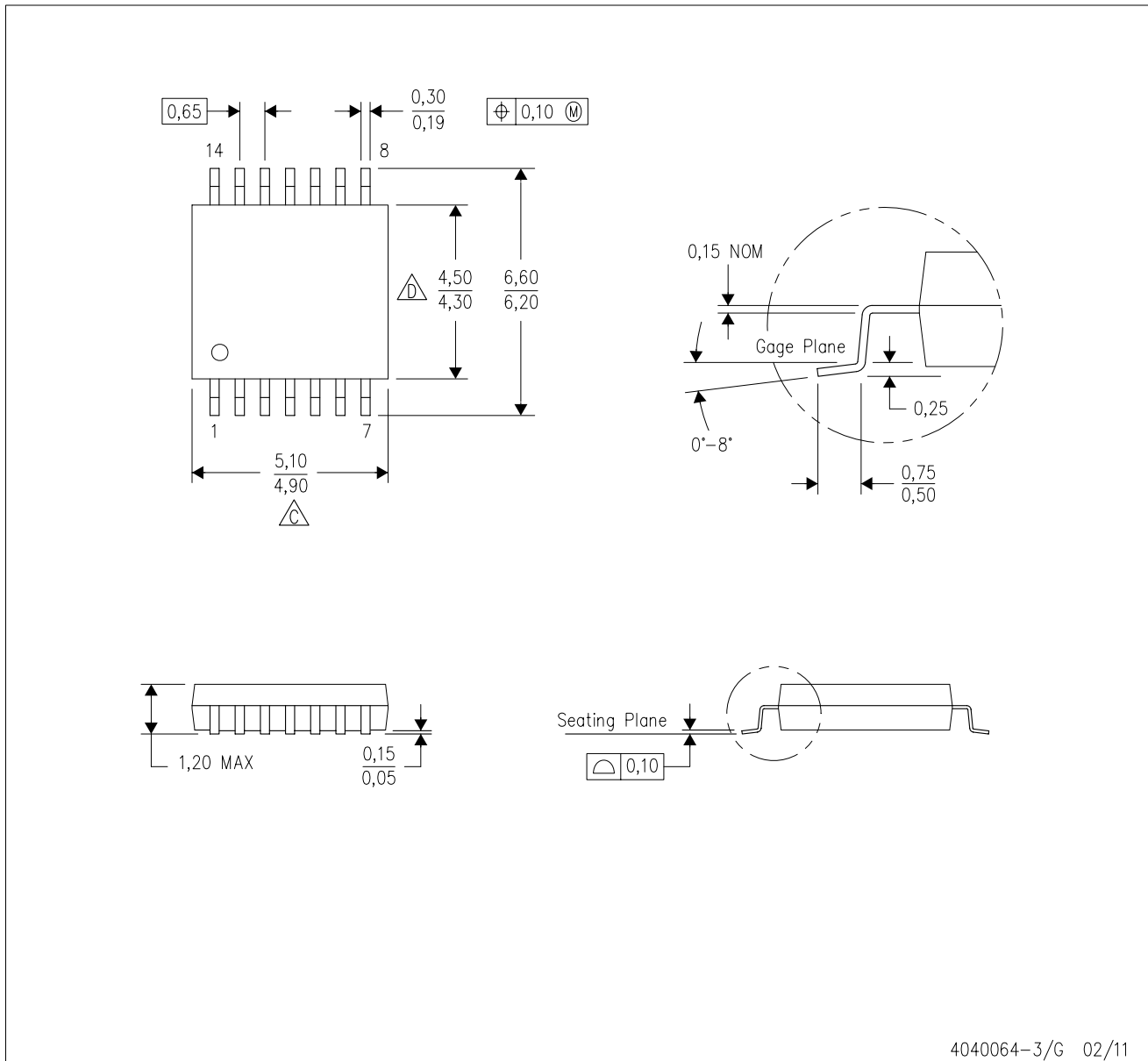

4040064-3/G 02/11

- NOTES:
- A. All linear dimensions are in millimeters. Dimensioning and tolerancing per ASME Y14.5M-1994.
  - B. This drawing is subject to change without notice.
  - C. Body length does not include mold flash, protrusions, or gate burrs. Mold flash, protrusions, or gate burrs shall not exceed 0,15 each side.
  - D. Body width does not include interlead flash. Interlead flash shall not exceed 0,25 each side.
  - E. Falls within JEDEC MO-153

PW (R-PDSO-G14)

PLASTIC SMALL OUTLINE

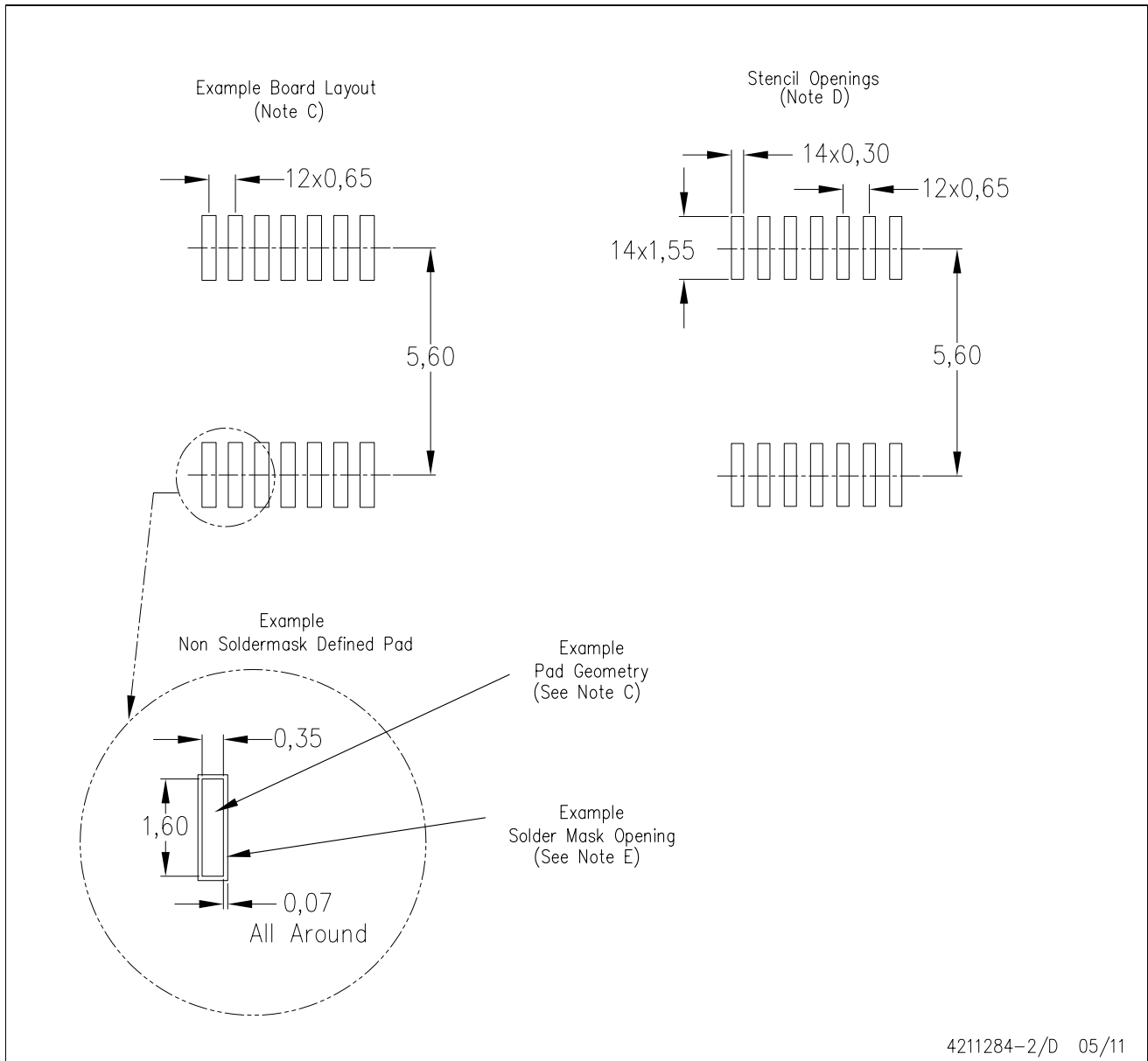

- NOTES:
- All linear dimensions are in millimeters.
  - This drawing is subject to change without notice.
  - Publication IPC-7351 is recommended for alternate designs.
  - Laser cutting apertures with trapezoidal walls and also rounding corners will offer better paste release. Customers should contact their board assembly site for stencil design recommendations. Refer to IPC-7525 for other stencil recommendations.
  - Customers should contact their board fabrication site for solder mask tolerances between and around signal pads.



## THERMAL PAD MECHANICAL DATA

RGT (S-PVQFN-N16)

PLASTIC QUAD FLATPACK NO-LEAD

### THERMAL INFORMATION

This package incorporates an exposed thermal pad that is designed to be attached directly to an external heatsink. The thermal pad must be soldered directly to the printed circuit board (PCB). After soldering, the PCB can be used as a heatsink. In addition, through the use of thermal vias, the thermal pad can be attached directly to the appropriate copper plane shown in the electrical schematic for the device, or alternatively, can be attached to a special heatsink structure designed into the PCB. This design optimizes the heat transfer from the integrated circuit (IC).

For information on the Quad Flatpack No-Lead (QFN) package and its advantages, refer to Application Report, QFN/SON PCB Attachment, Texas Instruments Literature No. SLUA271. This document is available at [www.ti.com](http://www.ti.com).

The exposed thermal pad dimensions for this package are shown in the following illustration.

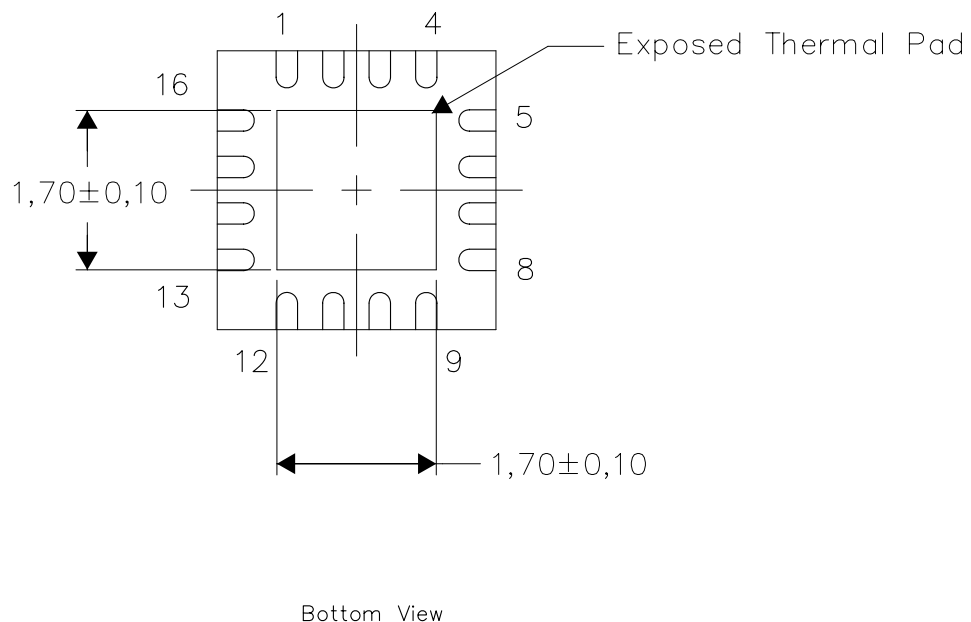

Exposed Thermal Pad Dimensions

4206349-4/0 11/10

NOTE: A. All linear dimensions are in millimeters

RGT (S-PVQFN-N16)

PLASTIC QUAD FLATPACK NO-LEAD

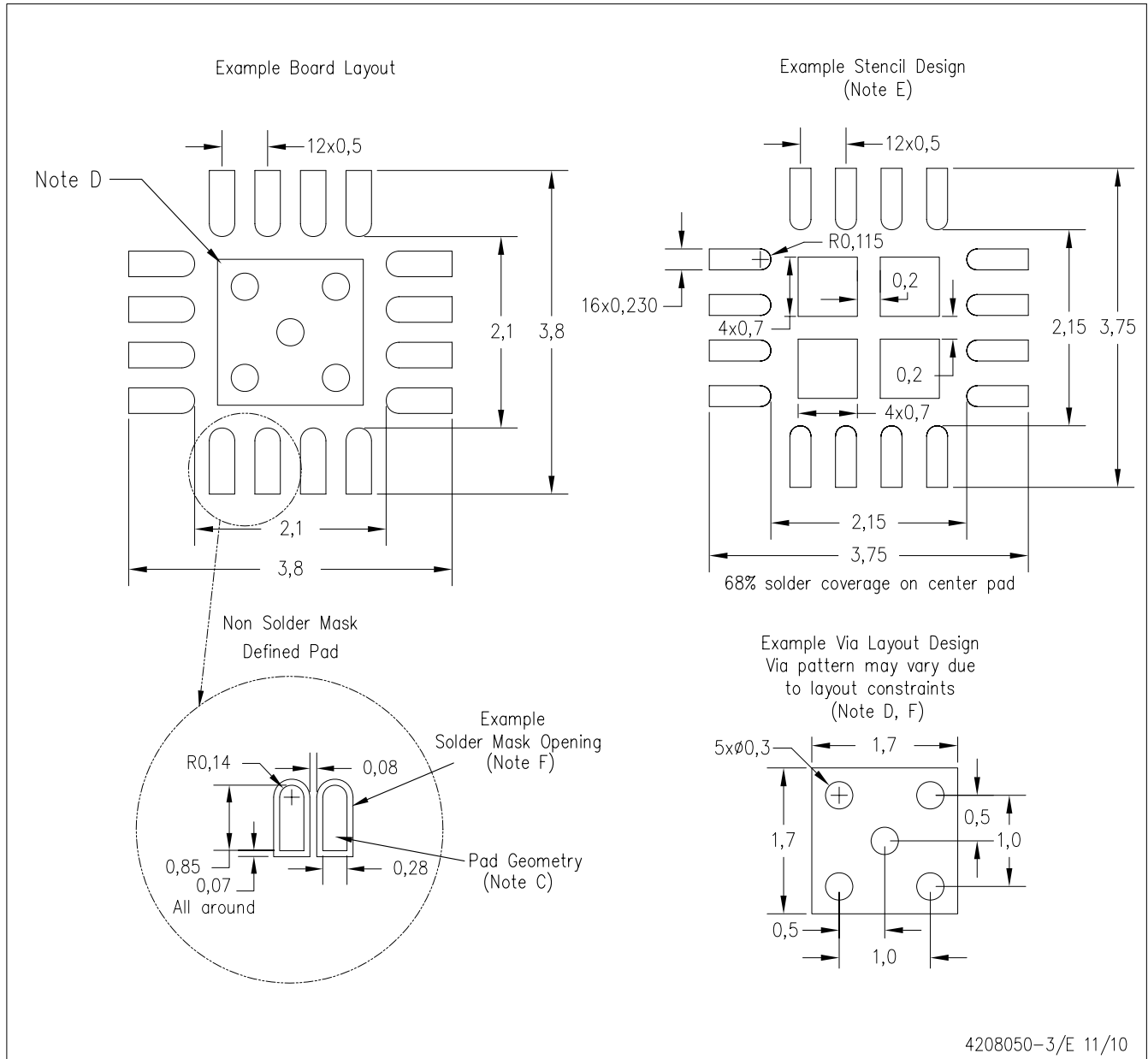

- NOTES:
- All linear dimensions are in millimeters.
  - This drawing is subject to change without notice.
  - Publication IPC-7351 is recommended for alternate designs.
  - This package is designed to be soldered to a thermal pad on the board. Refer to Application Note, QFN/SON PCB Attachment, Texas Instruments Literature No. SLUA271, and also the Product Data Sheets for specific thermal information, via requirements, and recommended board layout. These documents are available at [www.ti.com](http://www.ti.com) <<http://www.ti.com>>.
  - Laser cutting apertures with trapezoidal walls and also rounding corners will offer better paste release. Customers should contact their board assembly site for stencil design recommendations. Refer to IPC 7525 for stencil design considerations.
  - Customers should contact their board fabrication site for minimum solder mask web tolerances between signal pads.

## IMPORTANT NOTICE

Texas Instruments Incorporated and its subsidiaries (TI) reserve the right to make corrections, modifications, enhancements, improvements, and other changes to its products and services at any time and to discontinue any product or service without notice. Customers should obtain the latest relevant information before placing orders and should verify that such information is current and complete. All products are sold subject to TI's terms and conditions of sale supplied at the time of order acknowledgment.

TI warrants performance of its hardware products to the specifications applicable at the time of sale in accordance with TI's standard warranty. Testing and other quality control techniques are used to the extent TI deems necessary to support this warranty. Except where mandated by government requirements, testing of all parameters of each product is not necessarily performed.

TI assumes no liability for applications assistance or customer product design. Customers are responsible for their products and applications using TI components. To minimize the risks associated with customer products and applications, customers should provide adequate design and operating safeguards.

TI does not warrant or represent that any license, either express or implied, is granted under any TI patent right, copyright, mask work right, or other TI intellectual property right relating to any combination, machine, or process in which TI products or services are used. Information published by TI regarding third-party products or services does not constitute a license from TI to use such products or services or a warranty or endorsement thereof. Use of such information may require a license from a third party under the patents or other intellectual property of the third party, or a license from TI under the patents or other intellectual property of TI.

Reproduction of TI information in TI data books or data sheets is permissible only if reproduction is without alteration and is accompanied by all associated warranties, conditions, limitations, and notices. Reproduction of this information with alteration is an unfair and deceptive business practice. TI is not responsible or liable for such altered documentation. Information of third parties may be subject to additional restrictions.

Resale of TI products or services with statements different from or beyond the parameters stated by TI for that product or service voids all express and any implied warranties for the associated TI product or service and is an unfair and deceptive business practice. TI is not responsible or liable for any such statements.

TI products are not authorized for use in safety-critical applications (such as life support) where a failure of the TI product would reasonably be expected to cause severe personal injury or death, unless officers of the parties have executed an agreement specifically governing such use. Buyers represent that they have all necessary expertise in the safety and regulatory ramifications of their applications, and acknowledge and agree that they are solely responsible for all legal, regulatory and safety-related requirements concerning their products and any use of TI products in such safety-critical applications, notwithstanding any applications-related information or support that may be provided by TI. Further, Buyers must fully indemnify TI and its representatives against any damages arising out of the use of TI products in such safety-critical applications.

TI products are neither designed nor intended for use in military/aerospace applications or environments unless the TI products are specifically designated by TI as military-grade or "enhanced plastic." Only products designated by TI as military-grade meet military specifications. Buyers acknowledge and agree that any such use of TI products which TI has not designated as military-grade is solely at the Buyer's risk, and that they are solely responsible for compliance with all legal and regulatory requirements in connection with such use.

TI products are neither designed nor intended for use in automotive applications or environments unless the specific TI products are designated by TI as compliant with ISO/TS 16949 requirements. Buyers acknowledge and agree that, if they use any non-designated products in automotive applications, TI will not be responsible for any failure to meet such requirements.

Following are URLs where you can obtain information on other Texas Instruments products and application solutions:

### Products

Audio	<a href="http://www.ti.com/audio">www.ti.com/audio</a>
Amplifiers	<a href="http://amplifier.ti.com">amplifier.ti.com</a>
Data Converters	<a href="http://dataconverter.ti.com">dataconverter.ti.com</a>
DLP® Products	<a href="http://www.dlp.com">www.dlp.com</a>
DSP	<a href="http://dsp.ti.com">dsp.ti.com</a>
Clocks and Timers	<a href="http://www.ti.com/clocks">www.ti.com/clocks</a>
Interface	<a href="http://interface.ti.com">interface.ti.com</a>
Logic	<a href="http://logic.ti.com">logic.ti.com</a>
Power Mgmt	<a href="http://power.ti.com">power.ti.com</a>
Microcontrollers	<a href="http://microcontroller.ti.com">microcontroller.ti.com</a>
RFID	<a href="http://www.ti-rfid.com">www.ti-rfid.com</a>
RF/IF and ZigBee® Solutions	<a href="http://www.ti.com/lprf">www.ti.com/lprf</a>

### Applications

Communications and Telecom	<a href="http://www.ti.com/communications">www.ti.com/communications</a>
Computers and Peripherals	<a href="http://www.ti.com/computers">www.ti.com/computers</a>
Consumer Electronics	<a href="http://www.ti.com/consumer-apps">www.ti.com/consumer-apps</a>
Energy and Lighting	<a href="http://www.ti.com/energy">www.ti.com/energy</a>
Industrial	<a href="http://www.ti.com/industrial">www.ti.com/industrial</a>
Medical	<a href="http://www.ti.com/medical">www.ti.com/medical</a>
Security	<a href="http://www.ti.com/security">www.ti.com/security</a>
Space, Avionics and Defense	<a href="http://www.ti.com/space-avionics-defense">www.ti.com/space-avionics-defense</a>
Transportation and Automotive	<a href="http://www.ti.com/automotive">www.ti.com/automotive</a>
Video and Imaging	<a href="http://www.ti.com/video">www.ti.com/video</a>
Wireless	<a href="http://www.ti.com/wireless-apps">www.ti.com/wireless-apps</a>

TI E2E Community Home Page

[e2e.ti.com](http://e2e.ti.com)

Mailing Address: Texas Instruments, Post Office Box 655303, Dallas, Texas 75265  
Copyright © 2011, Texas Instruments Incorporated