



## Miniature, 2W, Isolated UNREGULATED DC/DC CONVERTERS

### FEATURES

- Up To 89% Efficiency
- Thermal Protection
- Device-to-Device Synchronization
- SO-28 Power Density of 106W/in<sup>3</sup> (6.5W/cm<sup>3</sup>)
- EN55022 Class B EMC Performance
- UL1950 Recognized Component
- JEDEC 14-Pin and SO-28 Packages

### APPLICATIONS

- Point-of-Use Power Conversion
- Ground Loop Elimination
- Data Acquisition
- Industrial Control and Instrumentation
- Test Equipment

### DESCRIPTION

The DCP02 series is a family of 2W, isolated, unregulated DC/DC converters. Requiring a minimum of external components and including on-chip device protection, the DCP02 series provides extra features such as output disable and synchronization of switching frequencies.

The use of a highly integrated package design results in highly reliable products with power densities of 79W/in<sup>3</sup> (4.8W/cm<sup>3</sup>) for DIP-14, and 106W/in<sup>3</sup> (6.5W/cm<sup>3</sup>) for SO-28. This combination of features and small size makes the DCP02 suitable for a wide range of applications.

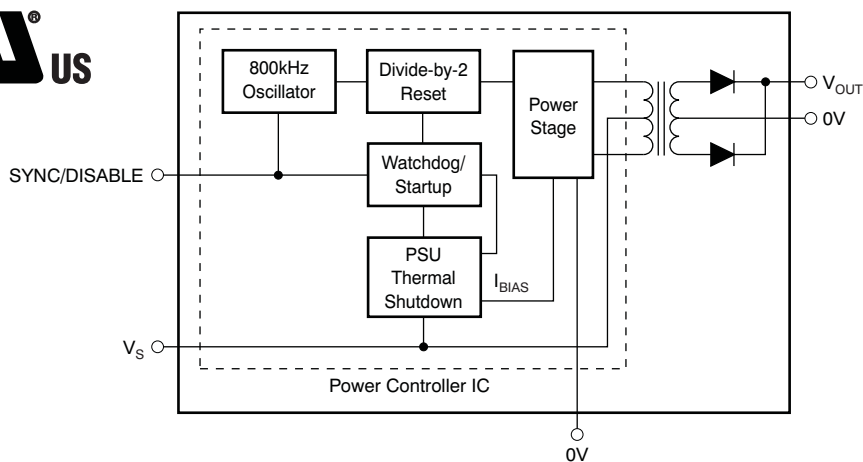

Please be aware that an important notice concerning availability, standard warranty, and use in critical applications of Texas Instruments semiconductor products and disclaimers thereto appears at the end of this data sheet.

All trademarks are the property of their respective owners.



This integrated circuit can be damaged by ESD. Texas Instruments recommends that all integrated circuits be handled with appropriate precautions. Failure to observe proper handling and installation procedures can cause damage.

ESD damage can range from subtle performance degradation to complete device failure. Precision integrated circuits may be more susceptible to damage because very small parametric changes could cause the device not to meet its published specifications.

### ORDERING INFORMATION

For the most current package and ordering information, see the Package Option Addendum at the end of this data sheet, or see the TI website at www.ti.com.

#### Supplemental Ordering Information

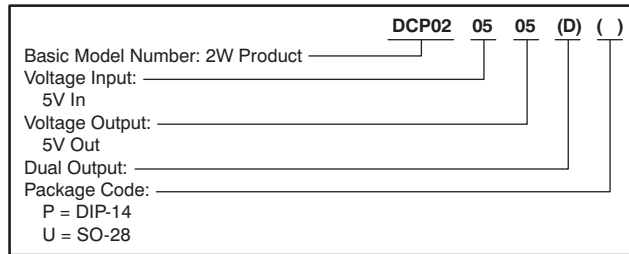

### ABSOLUTE MAXIMUM RATINGS

over operating free-air temperature range (unless otherwise noted) <sup>(1)</sup>

		DCP02 Series	UNIT
Input Voltage	5V input models	7	V
	12V input models	15	V
	15V input models	18	V
	24V input models	29	V
Storage temperature range		-60 to +125	°C

(1) Stresses beyond those listed under *Absolute Maximum Ratings* may cause permanent damage to the device. These are stress ratings only, and functional operation of the device at these or any other conditions beyond those indicated under recommended operating conditions is not implied. Exposure to absolute-maximum-rated conditions for extended periods may affect device reliability.

### ELECTRICAL CHARACTERISTICS

At T<sub>A</sub> = +25°C, unless otherwise noted.

PARAMETER	TEST CONDITIONS	MIN	TYP	MAX	UNIT
<b>OUTPUT</b>					
Power	100% full load		2		W
Ripple	O/P capacitor = 1µF, 50% load		20		mV <sub>PP</sub>
<b>INPUT</b>					
Voltage range on V <sub>S</sub>		-10		10	%
<b>ISOLATION</b>					
Voltage	1s Flash test	1			kVrms
	60s test, UL1950 <sup>(1)</sup>	1			kVrms
<b>LINE</b>					
Regulation			1		%/1% of V <sub>S</sub>

(1) During UL1950 recognition tests only.

**ELECTRICAL CHARACTERISTICS (continued)**

 At  $T_A = +25^\circ\text{C}$ , unless otherwise noted.

PARAMETER	TEST CONDITIONS	MIN	TYP	MAX	UNIT
<b>SWITCHING/SYNCHRONIZATION</b>					
Oscillator frequency ( $f_{\text{OSC}}$ )	Switching frequency = $f_{\text{OSC}}/2$		800		kHz
Sync input low		0		0.4	V
Sync input current	$V_{\text{SYNC}} = +2\text{V}$		75		$\mu\text{A}$
Disable time			2		$\mu\text{s}$
Capacitance loading on SYNC pin	External			10	pF
<b>RELIABILITY</b>					
Demonstrated	$T_A = +55^\circ\text{C}$	75			FITS
<b>THERMAL SHUTDOWN</b>					
IC temperature at shutdown			+150		$^\circ\text{C}$
Shutdown current			3		mA
<b>TEMPERATURE RANGE</b>					
Operating		–40		+85	$^\circ\text{C}$

**ELECTRICAL CHARACTERISTICS PER DEVICE**

 At  $T_A = +25^\circ\text{C}$ , unless otherwise noted.

PRODUCT	INPUT VOLTAGE (V)			OUTPUT VOLTAGE (V)			LOAD REGULATION (%)		NO LOAD CURRENT (mA)	EFFICIENCY (%)	BARRIER CAPACITANCE (pF)
	$V_S$			$V_{\text{NOM}}$					$I_q$		$C_{\text{ISO}}$
				75% LOAD <sup>(1)</sup>			10% TO 100% LOAD		0% LOAD	100% LOAD	$V_{\text{ISO}} = 750\text{V}_{\text{rms}}$
	MIN	TYP	MAX	MIN	TYP	MAX	TYP	MAX	TYP	TYP	TYP
DCP020503P, U	4.5	5	5.5	3.13	3.3	3.46	19	30	18	74	26
DCP020505P, U	4.5	5	5.5	4.75	5	5.25	14	20	18	80	22
DCP020507P, U	4.5	5	5.5	6.65	7	7.35	14	25	20	81	30
DCP020509P, U	4.5	5	5.5	8.55	9	9.45	12	20	23	82	31
DCP020512P	4.5	5	5.5	11.4	12	12.6	12	20	27	82	19
DCP020512DP	4.5	5	5.5	$\pm 11.4$	$\pm 12$	$\pm 12.6$	12	20	28	83	13
DCP020515DP, U	4.5	5	5.5	$\pm 14.25$	$\pm 15$	$\pm 15.75$	11	20	27	85	24
DCP020518DP	4.5	5	5.5	$\pm 17.1$	$\pm 18$	$\pm 18.9$	10	20	33	83	29
DCP021205P, U	10.8	12	13.2	4.75	5	5.25	7	15	14	83	33
DCP021212P, U	10.8	12	13.2	11.4	12	12.6	7	20	15	87	47
DCP021212DP, U	10.8	12	13.2	$\pm 11.4$	$\pm 12$	$\pm 12.6$	6	20	16	88	35
DCP021215DP	10.8	12	13.2	$\pm 14.25$	$\pm 15$	$\pm 15.75$	6	20	21	87	33
DCP021515P, U	13.5	15	16.5	14.25	15	15.75	6	20	15	88	42
DCP022405P	21.6	24	26.4	4.85	5	5.35	6	10	13	81	33
DCP022405U	21.6	24	26.4	4.75	5	5.25	10	15	13	81	33
DCP022405DP, U	21.6	24	26.4	$\pm 4.75$	$\pm 5$	$\pm 5.25$	6	15	12	80	22
DCP022412DP	21.6	24	26.4	$\pm 11.4$	$\pm 12$	$\pm 12.6$	4	16	19	83	29
DCP022415DP, U	21.6	24	26.4	$\pm 14.25$	$\pm 15$	$\pm 15.75$	6	25	16	79	44
DCP022418DP	21.6	24	26.4	$\pm 17.1$	$\pm 18$	$\pm 18.9$	9	25	20	84	32

 (1) 100% load current =  $2W/V_{\text{NOM}}$  typ.

DEVICE INFORMATION

NVA PACKAGE  
DIP-14 (Single-DIP)  
(Top View)

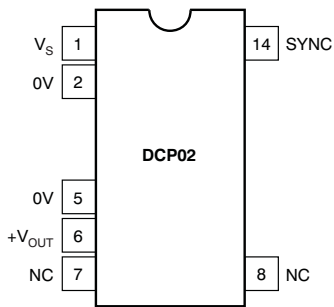

NVA PACKAGE  
DIP-14 (Dual-DIP)  
(Top View)

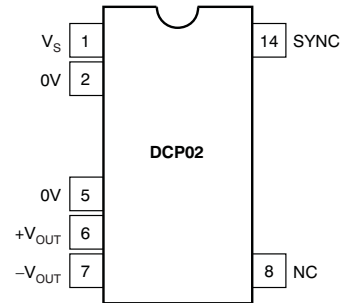

Table 1. Pin Description (Single-DIP)

TERMINAL		
NAME	NO.	DESCRIPTION
V <sub>S</sub>	1	Voltage input
0V	2	Input side common
0V	5	Output side common
+V <sub>OUT</sub>	6	+Voltage out
NC	7, 8	Not connected
SYNC	14	Synchronization pin

Table 3. TERMINAL FUNCTIONS (Dual-DIP)

TERMINAL		
NAME	NO.	DESCRIPTION
V <sub>S</sub>	1	Voltage input
0V	2	Input side common
0V	5	Output side common
+V <sub>OUT</sub>	6	+Voltage out
-V <sub>OUT</sub>	7	-Voltage out
NC	8	Not connected
SYNC	14	Synchronization pin

DVB PACKAGE  
SO-28 (Single-SO)  
(Top View)

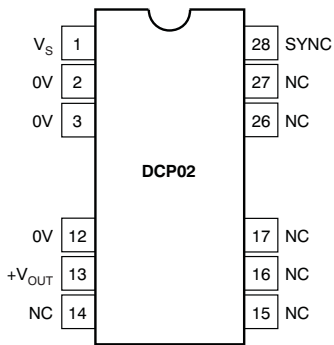

DVB PACKAGE  
SO-28 (Dual-SO)  
(Top View)

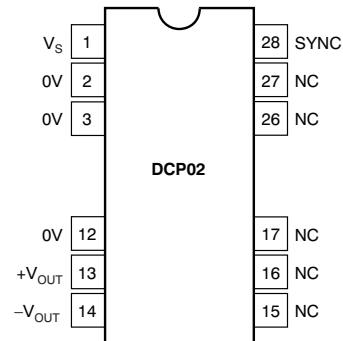

Table 2. TERMINAL FUNCTIONS (Single-SO)

TERMINAL		
NAME	NO.	DESCRIPTION
V <sub>S</sub>	1	Voltage input
0V	2	Input side common
0V	3	Input side common
0V	12	Output side common
+V <sub>OUT</sub>	13	+Voltage out
NC	14, 15, 16, 17, 26, 27	Not connected
SYNC	28	Synchronization pin

Table 4. TERMINAL FUNCTIONS (Dual-SO)

TERMINAL		
NAME	NO.	DESCRIPTION
V <sub>S</sub>	1	Voltage input
0V	2	Input side common
0V	3	Input side common
0V	12	Output side common
+V <sub>OUT</sub>	13	+Voltage out
-V <sub>OUT</sub>	14	-Voltage out
NC	15, 16, 17, 26, 27	Not connected
SYNC	28	Synchronization pin

**TYPICAL CHARACTERISTICS**

At  $T_A = +25^\circ\text{C}$ , unless otherwise noted.

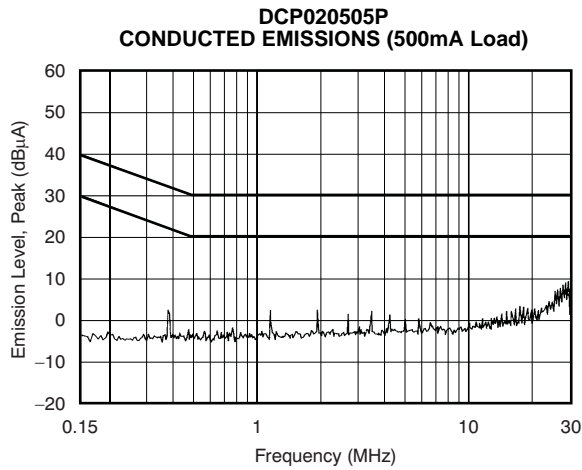

Figure 1.

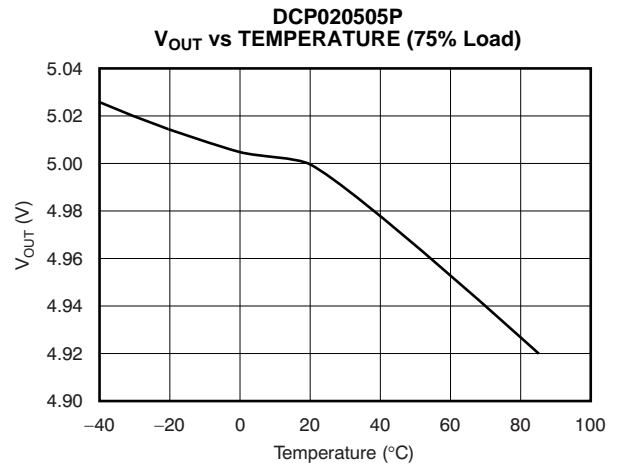

Figure 2.

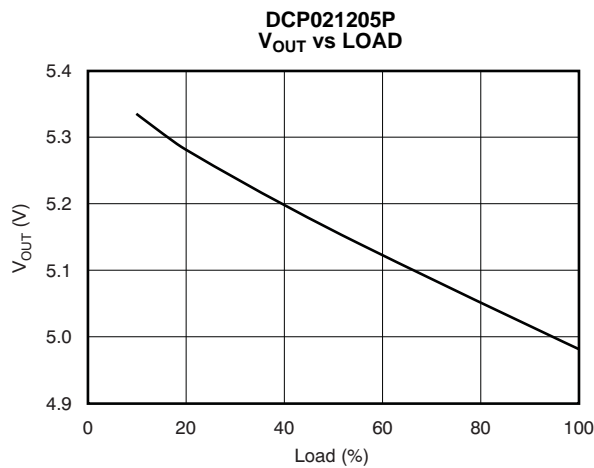

Figure 3.

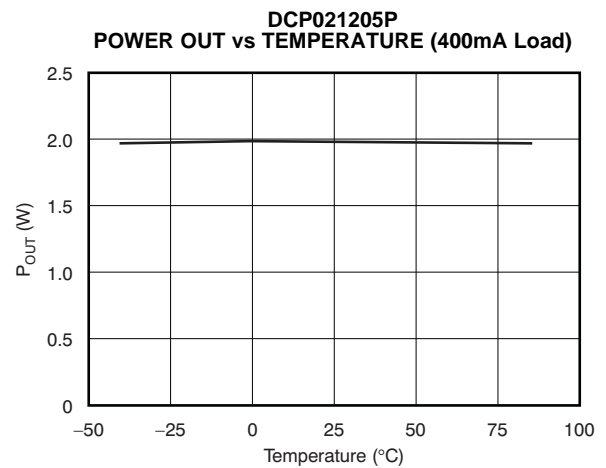

Figure 4.

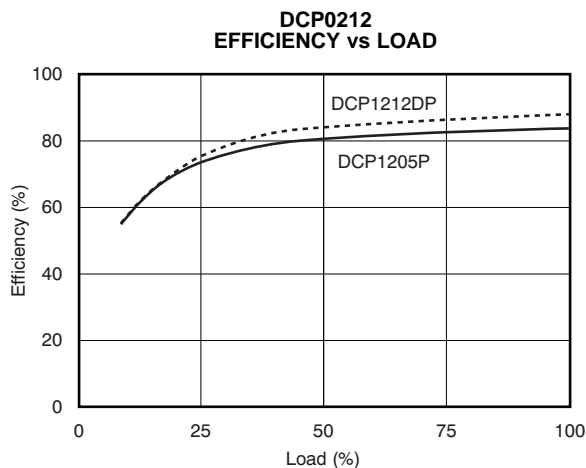

Figure 5.

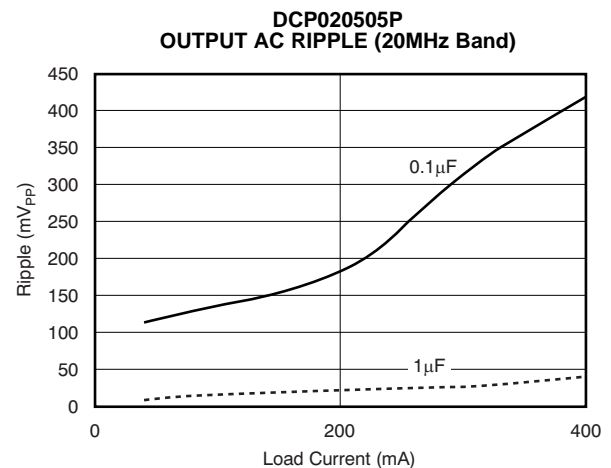

Figure 6.

## FUNCTIONAL DESCRIPTION

### OVERVIEW

The DCP02 offers up to 2W of unregulated output power from a 5V, 12V, 15V, or 24V input source with a typical efficiency of up to 89%. This efficiency is achieved through highly integrated packaging technology and the implementation of a custom power stage and control IC. The circuit design uses an advanced BiCMOS/DMOS process.

### POWER STAGE

The DCP02 uses a push-pull, center-tapped topology switching at 400kHz (divide-by-2 from an 800kHz oscillator).

### OSCILLATOR AND WATCHDOG

The onboard 800kHz oscillator generates the switching frequency via a divide-by-2 circuit. The oscillator can be synchronized to other DCP02 circuits or an external source, and is used to minimize system noise.

A watchdog circuit checks the operation of the oscillator circuit. The oscillator can be stopped by pulling the SYNC pin low. The output pins will be tri-stated, which occurs in 2 $\mu$ s.

### THERMAL SHUTDOWN

The DCP02 is protected by a thermal-shutdown circuit. If the on-chip temperature exceeds +150°C, the device will shut down. Once the temperature falls below +150°C, normal operation resumes.

### SYNCHRONIZATION

In the event that more than one DC/DC converter is needed onboard, beat frequencies and other electrical interference can be generated.

This interference occurs because of the small variations in switching frequencies between the DC/DC converters.

The DCP02 overcomes this interference by allowing devices to be synchronized to one another. Up to eight devices can be synchronized by connecting the SYNC pins together, taking care to minimize the capacitance of tracking. Stray capacitance (> 10pF) has the effect of reducing the switching frequency, or even stopping the oscillator circuit. It is also recommended that power and ground lines be star-connected.

It should be noted that if synchronized devices are used at start up, all devices will draw maximum current simultaneously. This configuration can cause the input voltage to dip; if it dips below the minimum input voltage (4.5V), the devices may not start up. A 2.2 $\mu$ F capacitor should be connected close to the input pins.

If more than eight devices are to be synchronized, it is recommended that the SYNC pins be driven by an external device. Details are contained in Application Report SBAA035, [External Synchronization of the DCP01/02 Series of DC/DC Converters](#), available for download from [www.ti.com](http://www.ti.com).

### CONSTRUCTION

The basic construction of the DCP02 is the same as standard ICs; there is no substrate within the molded package. The DCP02 is constructed using an IC, rectifier diodes, and a wound magnetic toroid on a leadframe. Since there is no solder within the package, the DCP02 does not require any special printed circuit board (PCB) assembly processing. This architecture results in an isolated DC/DC converter with inherently high reliability.

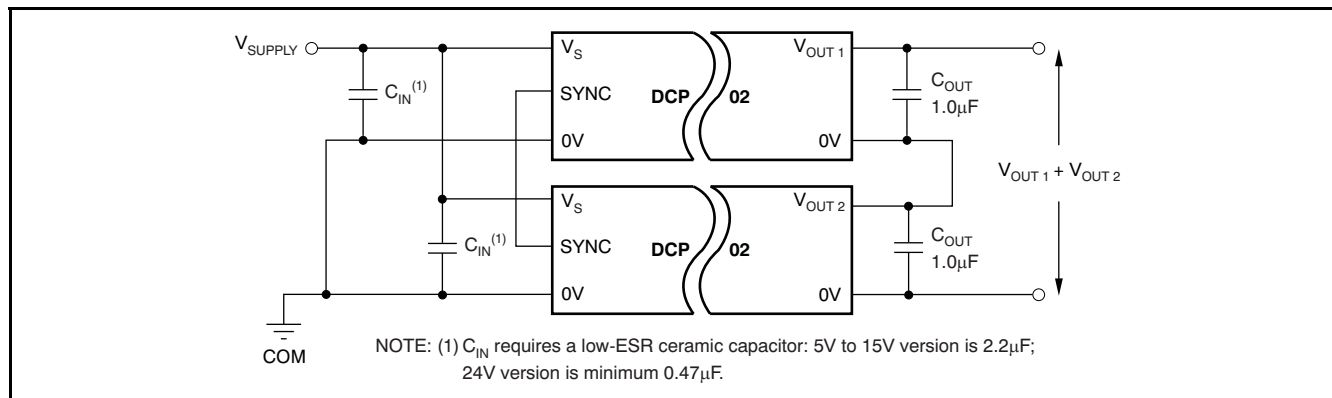

Figure 7. Connecting the DCP02 in Series

## ADDITIONAL FUNCTIONS

### DISABLE/ENABLE

The DCP02 can be disabled or enabled by driving the SYNC pin using an open drain CMOS gate. If the SYNC pin is pulled low, the DCP02 will be disabled. The disable time depends upon the external loading; the internal disable function is implemented in 2 $\mu$ s. Removal of the pull down causes the DCP02 to be enabled.

Capacitive loading on the SYNC pin should be minimized in order to prevent a reduction in the oscillator frequency.

### DECOUPLING

#### Ripple Reduction

The high switching frequency of 400kHz allows simple filtering. To reduce ripple, it is recommended that a 1 $\mu$ F capacitor be used on V<sub>OUT</sub>. Dual outputs should both be decoupled to pin 5. A 2.2 $\mu$ F capacitor on the input is also recommended.

### Connecting the DCP02 in Series

Multiple DCP02 isolated 2W DC/DC converters can be connected in series to provide nonstandard voltage rails. This configuration is possible by using the floating outputs provided by the galvanic isolation of the DCP02.

Connect the positive V<sub>OUT</sub> from one DCP02 to the negative V<sub>OUT</sub> (0V) of another (see Figure 7). If the SYNC pins are tied together, the self-synchronization feature of the DCP02 prevents beat frequencies on the voltage rails. The SYNC feature of the DCP02 allows easy series connection without external filtering, thus minimizing cost.

The outputs on the dual-output DCP02 versions can also be connected in series to provide two times the magnitude of V<sub>OUT</sub>, as shown in Figure 8. For example, a dual 15V DCP022415D could be connected to provide a 30V rail.

### Connecting the DCP02 in Parallel

If the output power from one DCP02 is not sufficient, it is possible to parallel the outputs of multiple DCP02s, as shown in Figure 9. Again, the SYNC feature allows easy synchronization to prevent power-rail beat frequencies at no additional filtering cost.

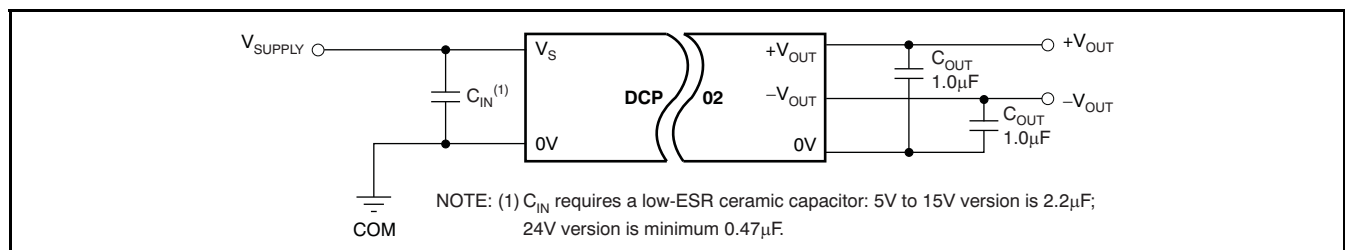

Figure 8. Connecting Dual Outputs in Series

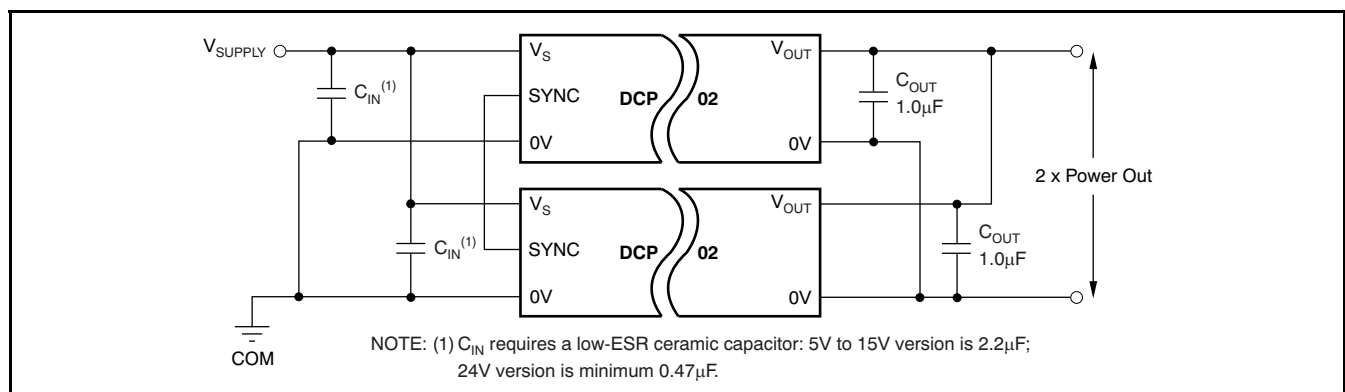

Figure 9. Connecting Multiple DCP02s in Parallel

## APPLICATION INFORMATION

The [DCP01B](#), [DCV01](#), and DCP02 are three families of miniature DC/DC converters providing an isolated unregulated voltage output. All are fabricated using a CMOS/DMOS process with the DCP01B replacing the familiar DCP01 family that was fabricated from a bipolar process. The DCP02 is essentially an extension of the DCP01B family, providing a higher power output with a significantly improved load regulation. The DCV01 is tested to a higher isolation voltage.

### TRANSFORMER DRIVE CIRCUIT

Transformer drive transistors have a characteristically low value of transistor *on* resistance ( $R_{DS}$ ); thus, more power is transferred to the transformer. The transformer drive circuit is limited by the base current available to switch on the power transistors driving the transformer and the characteristic current gain (beta), resulting in a slower turn-on time. Consequently, more power is dissipated within the transistor, resulting in a lower overall efficiency, particularly at higher output load currents.

### SELF-SYNCHRONIZATION

The input synchronizations facility ( $SYNC_{IN}$ ) allows for easy synchronizing of multiple devices. If two to eight devices (maximum) have their respective  $SYNC_{IN}$  pins connected together, then all devices will be synchronized.

Each device has its own onboard oscillator. This oscillator is generated by charging a capacitor from a constant current and producing a ramp. When this ramp passes a threshold, an internal switch is activated that discharges the capacitor to a second threshold before the cycle is repeated.

When several devices are connected together, all the internal capacitors are charged simultaneously.

When one device passes its threshold during the charge cycle, it starts the discharge cycle. All the other devices sense this falling voltage and, likewise, initiate a discharge cycle so that all devices discharge together. A subsequent charge cycle is only restarted when the last device has finished its discharge cycle.

### OPTIMIZING PERFORMANCE

Optimum performance can only be achieved if the device is correctly supported. The very nature of a switching converter requires power to be instantly available when it switches on. If the converter has DMOS switching transistors, the fast edges will create a high current demand on the input supply. This transient load placed on the input is supplied by the external input decoupling capacitor, thus maintaining the input voltage. Therefore, the input supply does not see this transient (this is an analogy to high-speed digital circuits). The positioning of the capacitor is critical and must be placed as close as possible to the input pins and connected via a low-impedance path.

The optimum performance primarily depends on two factors:

1. Connection of the input and output circuits for minimal loss.
2. The ability of the decoupling capacitors to maintain the input and output voltages at a constant level.

### PCB Design

The copper losses (resistance and inductance) can be minimized by the use of mutual ground and power planes (tracks) where possible. If that is not possible, use wide tracks to reduce the losses. If several devices are being powered from a common power source, a star-connected system for the track must be deployed; devices must not be connected in series, as this will cascade the resistive losses. The position of the decoupling capacitors is important. They must be as close to the devices as possible in order to reduce losses. See the [PCB Layout](#) section for more details.

## Decoupling Ceramic Capacitors

All capacitors have losses because of internal equivalent series resistance (ESR), and to a lesser degree, equivalent series inductance (ESL). Values for ESL are not always easy to obtain. However, some manufacturers provide graphs of frequency versus capacitor impedance. These graphs typically show the capacitor impedance falling as frequency is increased (as shown in Figure 10). As the frequency increases, the impedance stops decreasing and begins to rise. The point of minimum impedance indicates the resonant frequency of the capacitor. This frequency is where the components of capacitance and inductance reactance are of equal magnitude. Beyond this point, the capacitor is not effective as a capacitor.

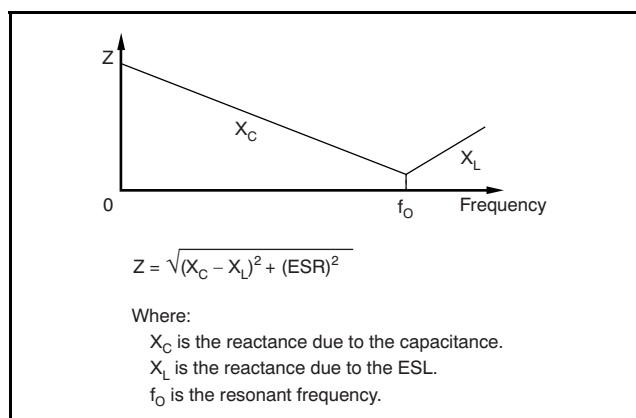

**Figure 10. Capacitor Impedance vs Frequency**

At  $f_0$ ,  $X_C = X_L$ ; however, there is a  $180^\circ$  phase difference resulting in cancellation of the imaginary component. The resulting effect is that the impedance at the resonant point is the real part of the complex impedance; namely, the value of the ESR. The resonant frequency must be well above the 800kHz switching frequency of the DCP and DCVs.

The effect of the ESR is to cause a voltage drop within the capacitor. The value of this voltage drop is simply the product of the ESR and the transient load current, as shown:

$$V_{IN} = V_{PK} - (ESR \times I_{TR}) \quad (1)$$

Where:

$V_{IN}$  is the voltage at the device input.

$V_{PK}$  is the maximum value of the voltage on the capacitor during charge.

$I_{TR}$  is the transient load current.

The other factor that affects the performance is the value of the capacitance. However, for the input and the full wave outputs (single-output voltage devices), ESR is the dominant factor.

## Input Capacitor and the Effects of ESR

If the input decoupling capacitor is not ceramic with  $< 20m\Omega$  ESR, then at the instant the power transistors switch on, the voltage at the input pins falls momentarily. Should the voltage fall below approximately 4V, the DCP detects an under-voltage condition and switches the DCP drive circuits to the off state. This detection is carried out as a precaution against a genuine low input voltage condition that could slow down or even stop the internal circuits from operating correctly. A slow-down or stoppage would result in the drive transistors being turned on too long, causing saturation of the transformer and destruction of the device.

Following detection of a low input voltage condition, the device switches off the internal drive circuits until the input voltage returns to a safe value. Then the device tries to restart. If the input capacitor is still unable to maintain the input voltage, shutdown recurs. This process is repeated until the capacitor is charged sufficiently to start the device correctly. Otherwise, the device will be caught up in a loop.

Normal startup should occur in approximately 1ms from power being applied to the device. If a considerably longer startup duration time is encountered, it is likely that either (or both) the input supply or the capacitors are not performing adequately.

For 5V to 15V input devices, a  $2.2\mu F$  low-ESR ceramic capacitor ensures a good startup performance. For the remaining input voltage ranges,  $0.47\mu F$  ceramic capacitors are recommended. Tantalum capacitors are not recommended, since most do not have low-ESR values and will degrade performance. If tantalum capacitors must be used, close attention must be paid to both the ESR and voltage as derated by the vendor.

### Output Ripple Calculation Example

DCP020505: Output voltage 5V, Output current 0.4A. At full output power, the load resistor is  $12.5\Omega$ . Output capacitor of  $1\mu F$ , ESR of  $0.1\Omega$ . Capacitor discharge time 1% of 800kHz (ripple frequency):

$$t_{DIS} = 0.0125\mu s$$

$$\tau = C \times R_{LOAD}$$

$$\tau = 1 \times 10^{-6} \times 12.5 = 12.5\mu s$$

$$V_{DIS} = V_O(1 - \text{EXP}(-t_{DIS}/\tau))$$

$$V_{DIS} = 5mV$$

By contrast, the voltage dropped because of ESR:

$$V_{ESR} = I_{LOAD} \times ESR$$

$$V_{ESR} = 40mV$$

$$\text{Ripple voltage} = 45mV$$

Clearly, increasing the capacitance has a much smaller effect on the output ripple voltage than does reducing the value of the ESR for the filter capacitor.

### DUAL OUTPUT VOLTAGE DCP AND DCVs

The voltage output for the dual DCPs is half wave rectified; therefore, the discharge time is 1.25 $\mu$ s. Repeating the above calculations using the 100% load resistance of 25 $\Omega$  (0.2A per output), the results are:

$$\tau = 25\mu\text{s}$$

$$t_{\text{DIS}} = 1.25\mu\text{s}$$

$$V_{\text{DIS}} = 244\text{mV}$$

$$V_{\text{ESR}} = 20\text{mV}$$

$$\text{Ripple Voltage} = 266\text{mV}$$

This time, it is the capacitor discharging that contributes to the largest component of ripple. Changing the output filter to 10 $\mu$ F, and repeating the calculations, the result is:

$$\text{Ripple Voltage} = 45\text{mV.}$$

This value is composed of almost equal components.

The previous calculations are given only as a guide. Capacitor parameters usually have large tolerances and can be susceptible to environmental conditions.

### PCB LAYOUT

Figure 11 and Figure 12 illustrate a printed circuit board (PCB) layout for the two conventional (DCP01/02, DCV01), and two SO-28 surface-mount packages (DCP02U). Figure 13 shows the schematic.

Input power and ground planes have been used, providing a low-impedance path for the input power. For the output, the common or 0V has been connected via a ground plane, while the connections for the positive and negative voltage outputs are conducted via wide traces in order to minimize losses.

The location of the decoupling capacitors in close proximity to their respective pins ensures low losses due to the effects of stray inductance, thus improving the ripple performance. This location is of particular importance to the input decoupling capacitor, because this capacitor supplies the transient current associated with the fast switching waveforms of the power drive circuits.

The SYNC<sub>IN</sub> pin, when not being used, is best left as a floating pad. A ground ring or annulus connected around the pin prevents noise being conducted onto the pin. If the SYNC<sub>IN</sub> pin is to be connected to one or more SYNC<sub>IN</sub> pins, then the linking trace should be narrow and must be kept short in length. In addition, no other trace should be in close proximity to this trace because that will increase the stray capacitance on this pin. In turn, the stray capacitance affects the performance of the oscillator.

### Ripple and Noise

Careful consideration should be given to the layout of the PCB in order to obtain the best results.

The DCP02 is a switching power supply, and as such can place high peak current demands on the input supply. In order to avoid the supply falling momentarily during the fast switching pulses, ground and power planes should be used to connect the power to the input of DCP02. If this connection is not possible, then the supplies must be connected in a star formation with the traces made as wide as possible.

If the SYNC<sub>IN</sub> pin is being used, then the trace connection between device SYNC<sub>IN</sub> pins should be short to avoid stray capacitance. If the SYNC<sub>IN</sub> pin is not being used, it is advisable to place a guard ring (connected to input ground) around this pin to avoid any noise pick up.

The output should be taken from the device using ground and power planes, thereby ensuring minimum losses.

A good quality low-ESR ceramic capacitor placed as close as practical across the input reduces reflected ripple and ensures a smooth startup.

A good quality low-ESR capacitor (ceramic preferred) placed as close as practical across the rectifier output terminal and output ground gives the best ripple and noise performance. See Application Bulletin [SBVA012, DC-to-DC Converter Noise Reduction](#), for more information on noise rejection.

### THERMAL MANAGEMENT

Because of the high power density of this device, it is advisable to provide ground planes on the input and output.

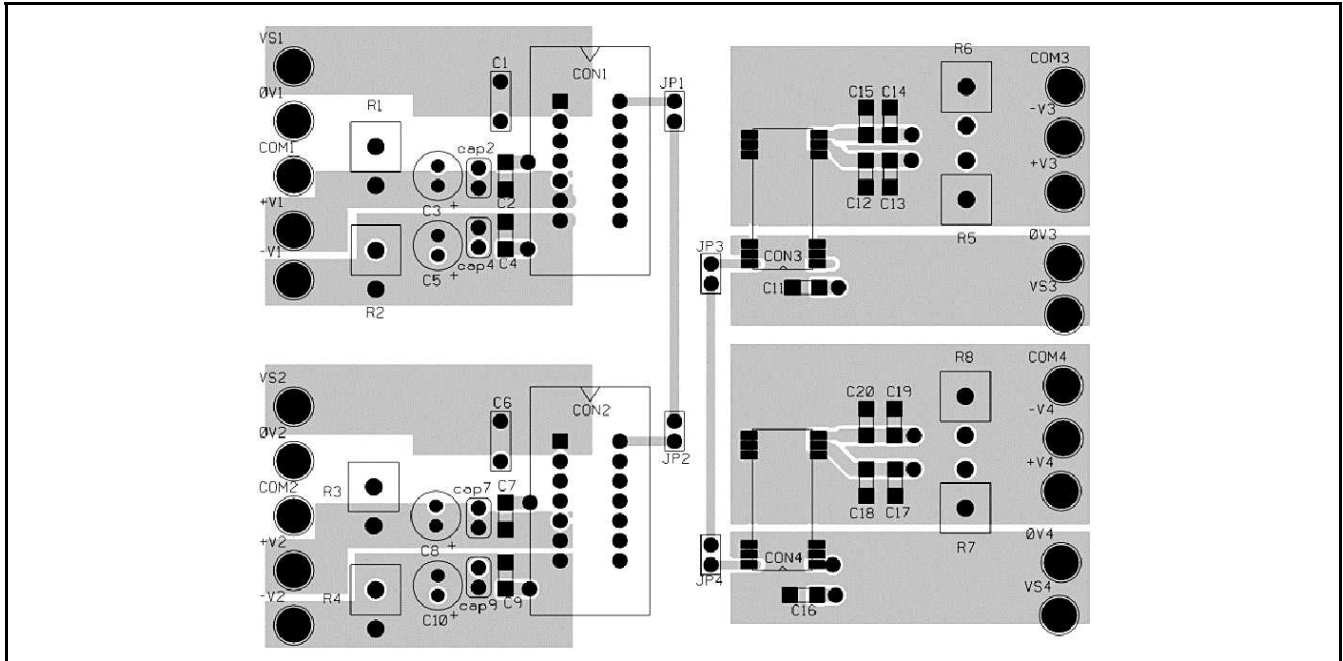

Figure 11. Example of PCB Layout, Component-Side View

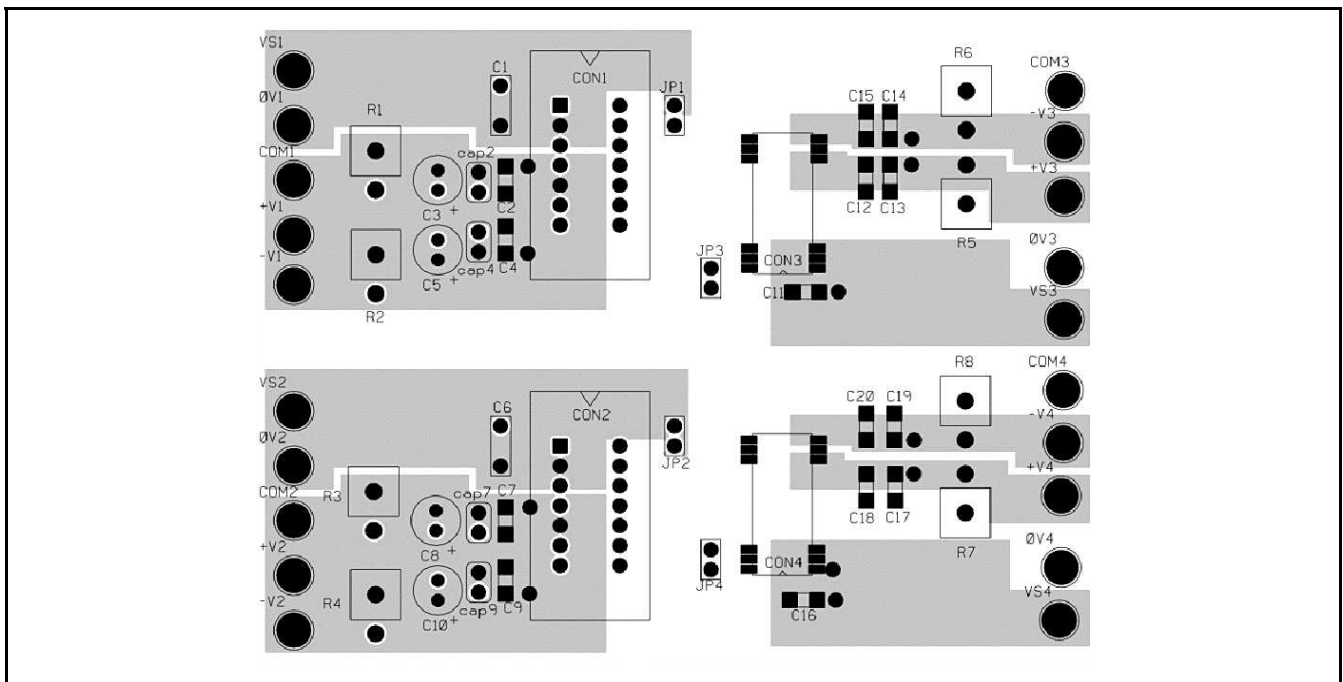

Figure 12. Example of PCB Layout, Non-Component-Side View

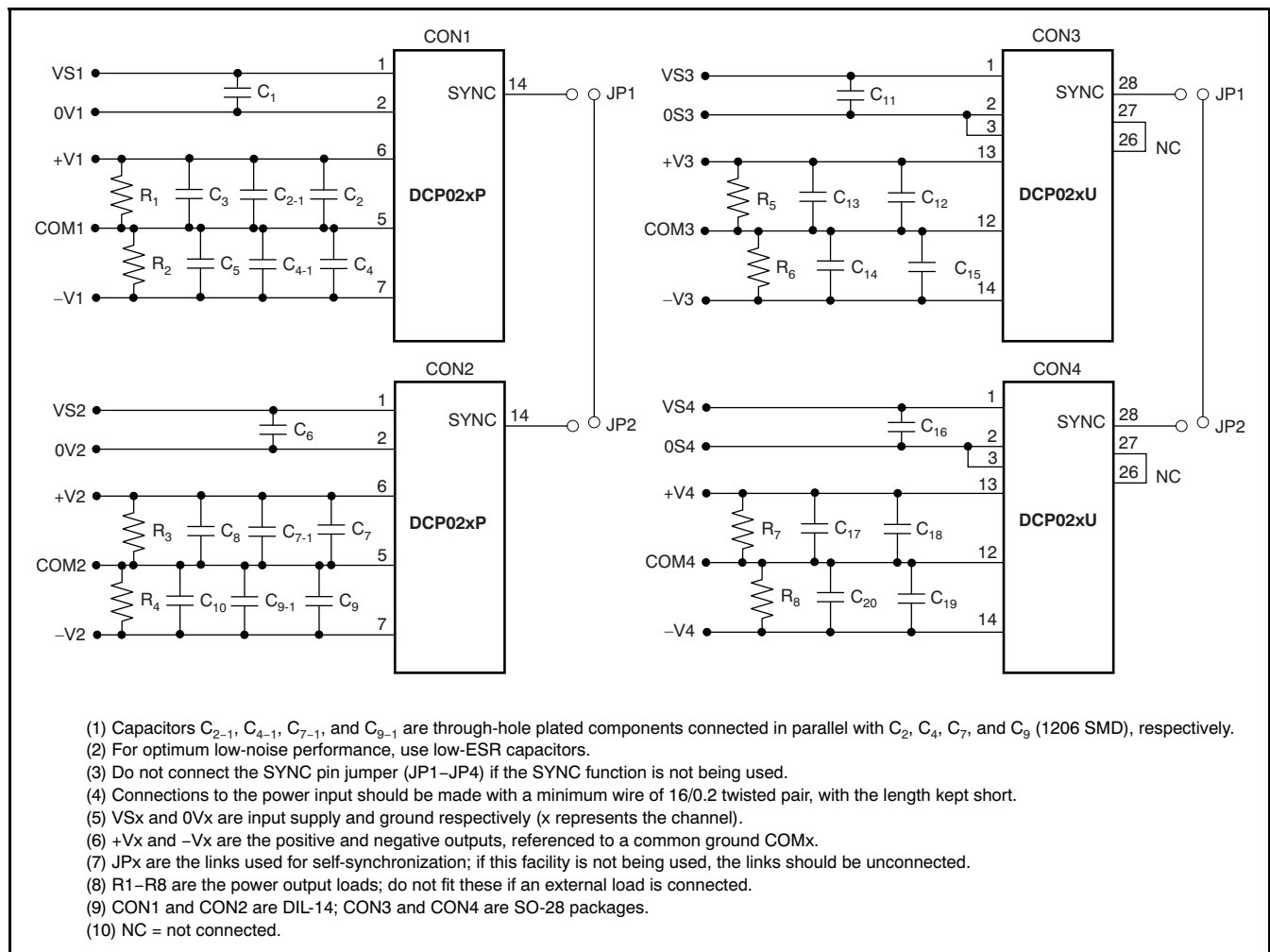

Figure 13. Example of PCB Layout, Schematic Diagram

**PACKAGING INFORMATION**

Orderable Device	Status <sup>(1)</sup>	Package Type	Package Drawing	Pins	Package Qty	Eco Plan <sup>(2)</sup>	Lead/Ball Finish	MSL Peak Temp <sup>(3)</sup>
DCP020503P	ACTIVE	PDIP	NVA	7	25	Pb-Free (RoHS)	CU NIPDAU	N / A for Pkg Type
DCP020503U	ACTIVE	SOP	DVB	12	28	TBD	CU NIPDAU	Level-3-240C-168 HR
DCP020503U/1K	ACTIVE	SOP	DVB	12	1000	TBD	CU NIPDAU	Level-3-240C-168 HR
DCP020505P	ACTIVE	PDIP	NVA	7	25	TBD	CU NIPDAU	N / A for Pkg Type
DCP020505U	ACTIVE	SOP	DVB	12	28	Pb-Free (RoHS)	CU NIPDAU	Level-3-260C-168 HR
DCP020505U/1K	ACTIVE	SOP	DVB	12	1000	Pb-Free (RoHS)	CU NIPDAU	Level-3-260C-168 HR
DCP020505U/1KE4	ACTIVE	SOP	DVB	12	1000	Pb-Free (RoHS)	CU NIPDAU	Level-3-260C-168 HR
DCP020505UE4	ACTIVE	SOP	DVB	12	28	Pb-Free (RoHS)	CU NIPDAU	Level-3-260C-168 HR
DCP020507P	ACTIVE	PDIP	NVA	7	25	Pb-Free (RoHS)	CU NIPDAU	N / A for Pkg Type
DCP020507U	ACTIVE	SOP	DVB	12	28	TBD	CU NIPDAU	Level-3-240C-168 HR
DCP020507U/1K	ACTIVE	SOP	DVB	12	1000	TBD	CU NIPDAU	Level-3-240C-168 HR
DCP020509P	ACTIVE	PDIP	NVA	7	25	Pb-Free (RoHS)	CU NIPDAU	N / A for Pkg Type
DCP020509U	ACTIVE	SOP	DVB	12	28	Pb-Free (RoHS)	CU NIPDAU	Level-3-260C-168 HR
DCP020515DP	ACTIVE	PDIP	NVA	7	25	Pb-Free (RoHS)	CU NIPDAU	N / A for Pkg Type
DCP020515DU	ACTIVE	SOP	DVB	12	28	Pb-Free (RoHS)	CU NIPDAU	Level-3-260C-168 HR
DCP020515DU/1K	ACTIVE	SOP	DVB	12	1000	Pb-Free (RoHS)	CU NIPDAU	Level-3-260C-168 HR
DCP021205P	ACTIVE	PDIP	NVA	7	25	Pb-Free (RoHS)	Call TI	N / A for Pkg Type
DCP021205PE4	ACTIVE	PDIP	NVA	7	25	Pb-Free (RoHS)	Call TI	N / A for Pkg Type
DCP021205U	ACTIVE	SOP	DVB	12	28	Pb-Free (RoHS)	Call TI	Level-3-260C-168 HR
DCP021205U/1K	ACTIVE	SOP	DVB	12	1000	Pb-Free (RoHS)	Call TI	Level-3-260C-168 HR
DCP021212DP	ACTIVE	PDIP	NVA	7	25	Pb-Free (RoHS)	CU NIPDAU	N / A for Pkg Type
DCP021212DU	ACTIVE	SOP	DVB	12	28	Pb-Free (RoHS)	CU NIPDAU	Level-3-260C-168 HR
DCP021212DU/1K	ACTIVE	SOP	DVB	12	1000	Pb-Free (RoHS)	CU NIPDAU	Level-3-260C-168 HR
DCP021212P	ACTIVE	PDIP	NVA	7	25	TBD	CU NIPDAU	N / A for Pkg Type
DCP021212U	ACTIVE	SOP	DVB	12	28	TBD	CU NIPDAU	Level-3-240C-168 HR
DCP021212U/1K	ACTIVE	SOP	DVB	12	1000	TBD	CU NIPDAU	Level-3-240C-168 HR
DCP021215DP	ACTIVE	PDIP	NVA	7	25	TBD	Call TI	Call TI
DCP021515P	ACTIVE	PDIP	NVA	7	25	Pb-Free (RoHS)	Call TI	N / A for Pkg Type
DCP021515PE4	ACTIVE	PDIP	NVA	7	25	Pb-Free	Call TI	N / A for Pkg Type

Orderable Device	Status <sup>(1)</sup>	Package Type	Package Drawing	Pins	Package Qty	Eco Plan <sup>(2)</sup>	Lead/Ball Finish	MSL Peak Temp <sup>(3)</sup>
(RoHS)								
DCP021515U	ACTIVE	SOP	DVB	12	28	TBD	CU NIPDAU	Level-3-240C-168 HR
DCP021515U/1K	ACTIVE	SOP	DVB	12	1000	TBD	CU NIPDAU	Level-3-240C-168 HR
DCP022405DP	ACTIVE	PDIP	NVA	7	25	Pb-Free (RoHS)	CU NIPDAU	N / A for Pkg Type
DCP022405DU	ACTIVE	SOP	DVB	12	28	TBD	CU NIPDAU	Level-3-240C-168 HR
DCP022405DU/1K	ACTIVE	SOP	DVB	12	1000	TBD	CU NIPDAU	Level-3-240C-168 HR
DCP022405P	ACTIVE	PDIP	NVA	7	25	Pb-Free (RoHS)	CU NIPDAULATEN	/ A for Pkg Type
DCP022405U	ACTIVE	SOP	DVB	12	28	TBD	CU NIPDAU	Level-3-240C-168 HR
DCP022405U/1K	ACTIVE	SOP	DVB	12	1000	TBD	CU NIPDAU	Level-3-240C-168 HR
DCP022412DP	ACTIVE	PDIP	NVA	7	25	TBD	Call TI	Call TI
DCP022415DP	ACTIVE	PDIP	NVA	7	25	Pb-Free (RoHS)	CU NIPDAU	N / A for Pkg Type
DCP022415DU	ACTIVE	SOP	DVB	12	28	TBD	CU NIPDAU	Level-3-240C-168 HR
DCP022415DU/1K	ACTIVE	SOP	DVB	12	1000	TBD	CU NIPDAU	Level-3-240C-168 HR
DCP022418DP	ACTIVE	PDIP	NVA	7	25	TBD	Call TI	Call TI

<sup>(1)</sup> The marketing status values are defined as follows:

**ACTIVE:** Product device recommended for new designs.

**LIFEBUY:** TI has announced that the device will be discontinued, and a lifetime-buy period is in effect.

**NRND:** Not recommended for new designs. Device is in production to support existing customers, but TI does not recommend using this part in a new design.

**PREVIEW:** Device has been announced but is not in production. Samples may or may not be available.

**OBSELETE:** TI has discontinued the production of the device.

<sup>(2)</sup> Eco Plan - The planned eco-friendly classification: Pb-Free (RoHS), Pb-Free (RoHS Exempt), or Green (RoHS & no Sb/Br) - please check <http://www.ti.com/productcontent> for the latest availability information and additional product content details.

**TBD:** The Pb-Free/Green conversion plan has not been defined.

**Pb-Free (RoHS):** TI's terms "Lead-Free" or "Pb-Free" mean semiconductor products that are compatible with the current RoHS requirements for all 6 substances, including the requirement that lead not exceed 0.1% by weight in homogeneous materials. Where designed to be soldered at high temperatures, TI Pb-Free products are suitable for use in specified lead-free processes.

**Pb-Free (RoHS Exempt):** This component has a RoHS exemption for either 1) lead-based flip-chip solder bumps used between the die and package, or 2) lead-based die adhesive used between the die and leadframe. The component is otherwise considered Pb-Free (RoHS compatible) as defined above.

**Green (RoHS & no Sb/Br):** TI defines "Green" to mean Pb-Free (RoHS compatible), and free of Bromine (Br) and Antimony (Sb) based flame retardants (Br or Sb do not exceed 0.1% by weight in homogeneous material)

<sup>(3)</sup> MSL, Peak Temp. -- The Moisture Sensitivity Level rating according to the JEDEC industry standard classifications, and peak solder temperature.

**Important Information and Disclaimer:**The information provided on this page represents TI's knowledge and belief as of the date that it is provided. TI bases its knowledge and belief on information provided by third parties, and makes no representation or warranty as to the accuracy of such information. Efforts are underway to better integrate information from third parties. TI has taken and continues to take reasonable steps to provide representative and accurate information but may not have conducted destructive testing or chemical analysis on incoming materials and chemicals. TI and TI suppliers consider certain information to be proprietary, and thus CAS numbers and other limited information may not be available for release.

In no event shall TI's liability arising out of such information exceed the total purchase price of the TI part(s) at issue in this document sold by TI to Customer on an annual basis.

NVA (R-PDIP-T7/14)

PLASTIC DUAL-IN-LINE

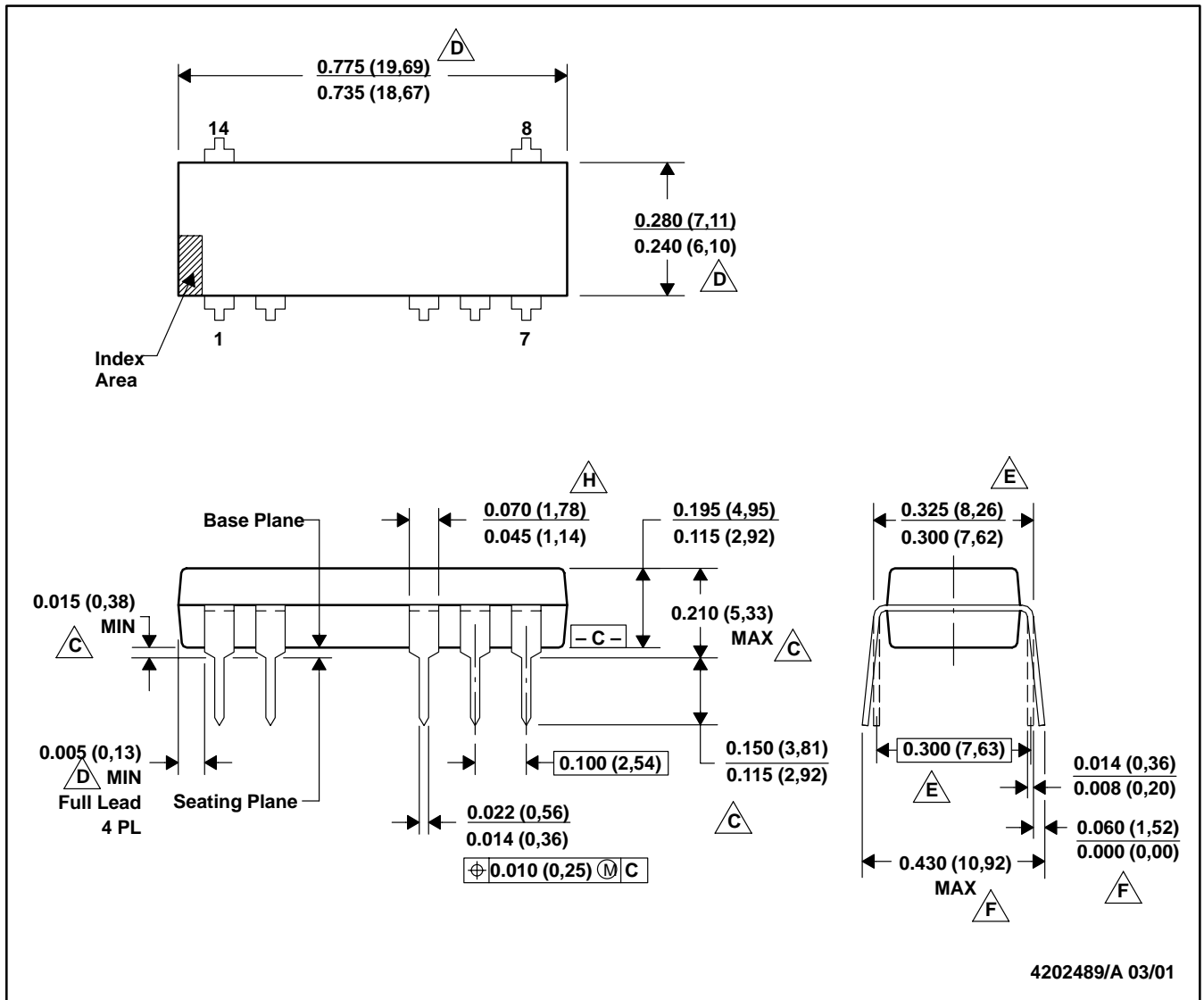

NOTES: A. All linear dimensions are in inches (millimeters).

B. This drawing is subject to change without notice.

C. Dimensions are measured with the package seated in JEDEC seating plane gauge GS-3.

D. Dimensions do not include mold flash or protrusions. Mold flash or protrusions shall not exceed 0.010 (0,25).

E. Dimensions measured with the leads constrained to be perpendicular to Datum C.

F. Dimensions are measured at the lead tips with the leads unconstrained.

G. Pointed or rounded lead tips are preferred to ease insertion.

H. Lead shoulder maximum dimension does not include dambar protrusions. Dambar protrusions shall not exceed 0.010 (0,25).

I. Distance between leads including dambar protrusions to be 0.005 (0,13) minimum.

J. A visual index feature must be located within the cross-hatched area.

K. For automatic insertion, any raised irregularity on the top surface (step, mesa, etc.) shall be symmetrical about the lateral and longitudinal package centerlines.

L. Falls within JEDEC MS-001-AA.

DVB(R-PDSO-G12/28)

PLASTIC SMALL-OUTLINE

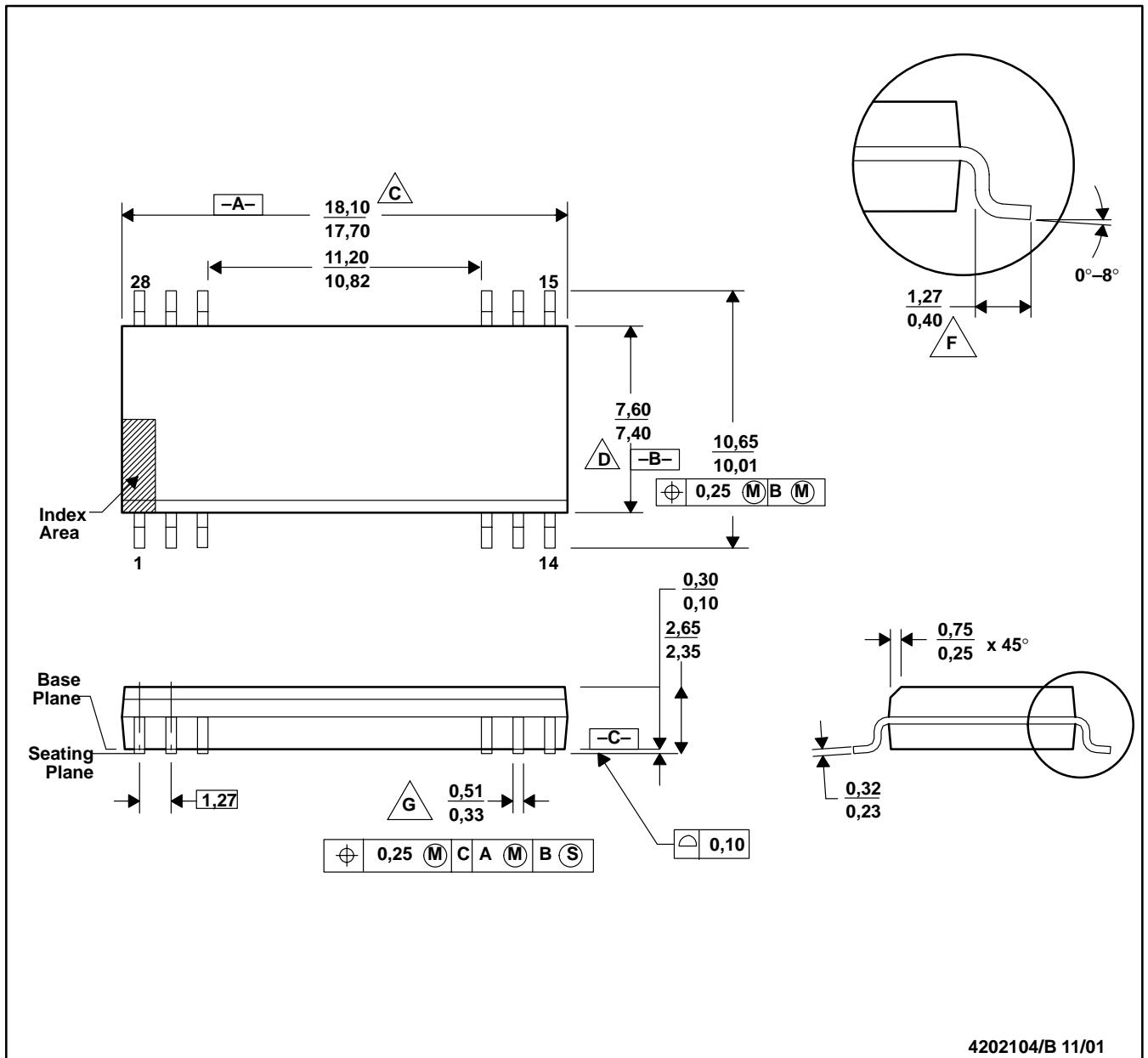

4202104/B 11/01

NOTES: A. All linear dimensions are in millimeters.

B. This drawing is subject to change without notice.

C. Body length dimension does not include mold flash, protrusions, or gate burrs. Mold flash, protrusions, and gate burrs shall not exceed 0,15 mm per side.

D. Body width dimension does not include inter-lead flash or protrusions. Inter-lead flash and protrusions shall not exceed 0,25 mm per side.

E. The chamfer on the body is optional. If it is not present, a visual index feature must be located within the cross-hatched area.

F. Lead dimension is the length of terminal for soldering to a substrate.

G. Lead width, as measured 0,36 mm or greater above the seating plane, shall not exceed a maximum value of 0,61 mm.

H. Lead-to-lead coplanarity shall be less than 0,10 mm from seating plane.

I. Falls within JEDEC MS-013-AE with the exception of the number of leads.



## IMPORTANT NOTICE

Texas Instruments Incorporated and its subsidiaries (TI) reserve the right to make corrections, modifications, enhancements, improvements, and other changes to its products and services at any time and to discontinue any product or service without notice. Customers should obtain the latest relevant information before placing orders and should verify that such information is current and complete. All products are sold subject to TI's terms and conditions of sale supplied at the time of order acknowledgment.

TI warrants performance of its hardware products to the specifications applicable at the time of sale in accordance with TI's standard warranty. Testing and other quality control techniques are used to the extent TI deems necessary to support this warranty. Except where mandated by government requirements, testing of all parameters of each product is not necessarily performed.

TI assumes no liability for applications assistance or customer product design. Customers are responsible for their products and applications using TI components. To minimize the risks associated with customer products and applications, customers should provide adequate design and operating safeguards.

TI does not warrant or represent that any license, either express or implied, is granted under any TI patent right, copyright, mask work right, or other TI intellectual property right relating to any combination, machine, or process in which TI products or services are used. Information published by TI regarding third-party products or services does not constitute a license from TI to use such products or services or a warranty or endorsement thereof. Use of such information may require a license from a third party under the patents or other intellectual property of the third party, or a license from TI under the patents or other intellectual property of TI.

Reproduction of information in TI data books or data sheets is permissible only if reproduction is without alteration and is accompanied by all associated warranties, conditions, limitations, and notices. Reproduction of this information with alteration is an unfair and deceptive business practice. TI is not responsible or liable for such altered documentation.

Resale of TI products or services with statements different from or beyond the parameters stated by TI for that product or service voids all express and any implied warranties for the associated TI product or service and is an unfair and deceptive business practice. TI is not responsible or liable for any such statements.

Following are URLs where you can obtain information on other Texas Instruments products and application solutions:

### Products

Amplifiers	<a href="http://amplifier.ti.com">amplifier.ti.com</a>
Data Converters	<a href="http://dataconverter.ti.com">dataconverter.ti.com</a>
DSP	<a href="http://dsp.ti.com">dsp.ti.com</a>
Interface	<a href="http://interface.ti.com">interface.ti.com</a>
Logic	<a href="http://logic.ti.com">logic.ti.com</a>
Power Mgmt	<a href="http://power.ti.com">power.ti.com</a>
Microcontrollers	<a href="http://microcontroller.ti.com">microcontroller.ti.com</a>
Low Power Wireless	<a href="http://www.ti.com/lpw">www.ti.com/lpw</a>

### Applications

Audio	<a href="http://www.ti.com/audio">www.ti.com/audio</a>
Automotive	<a href="http://www.ti.com/automotive">www.ti.com/automotive</a>
Broadband	<a href="http://www.ti.com/broadband">www.ti.com/broadband</a>
Digital Control	<a href="http://www.ti.com/digitalcontrol">www.ti.com/digitalcontrol</a>
Military	<a href="http://www.ti.com/military">www.ti.com/military</a>
Optical Networking	<a href="http://www.ti.com/opticalnetwork">www.ti.com/opticalnetwork</a>
Security	<a href="http://www.ti.com/security">www.ti.com/security</a>
Telephony	<a href="http://www.ti.com/telephony">www.ti.com/telephony</a>
Video & Imaging	<a href="http://www.ti.com/video">www.ti.com/video</a>
Wireless	<a href="http://www.ti.com/wireless">www.ti.com/wireless</a>

Mailing Address: Texas Instruments  
Post Office Box 655303 Dallas, Texas 75265