



Burr-Brown Products
from Texas Instruments

**DCP01B
Series**



www.ti.com

Miniature, 1W Isolated UNREGULATED DC/DC CONVERTERS

FEATURES

- UP TO 85% EFFICIENCY
- THERMAL PROTECTION
- DEVICE-TO-DEVICE SYNCHRONIZATION
- SHORT CIRCUIT PROTECTION
- EN55022 CLASS B EMC PERFORMANCE
- UL1950 RECOGNIZED COMPONENT
- JEDEC PDIP-14 AND GULL-WING PACKAGES

APPLICATIONS

- POINT-OF-USE POWER CONVERSION
- GROUND LOOP ELIMINATION
- DATA ACQUISITION
- INDUSTRIAL CONTROL AND INSTRUMENTATION
- TEST EQUIPMENT

DESCRIPTION

The DCP01B series is a family of 1W, unregulated, isolated DC/DC converters. Requiring a minimum of external components and including on-chip device protection, the DCP01B series provides extra features such as output disable and synchronization of switching frequencies.

The use of a highly integrated package design results in highly reliable products with a power density of 40W/in³ (2.4W/cm³). This combination of features and small size makes the DCP01B suitable for a wide range of applications.

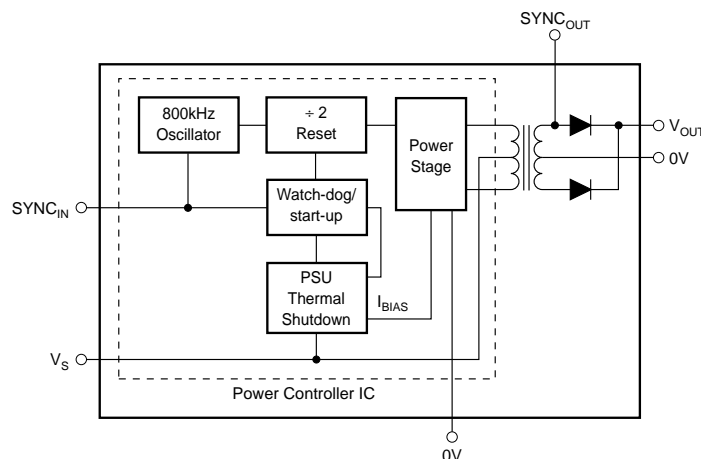

SPECIFICATIONS

At $T_A = +25^\circ\text{C}$, unless otherwise specified.

PARAMETER	CONDITIONS	DCP01B SERIES			UNITS
		MIN	TYP	MAX	
OUTPUT Power Ripple Voltage vs Temp	100% Full Load O/P Capacitor = $1\mu\text{F}$, 50% Load Room to Cold Room to Hot		0.97 20 0.046 0.016		W mVp-p %/°C %/°C
INPUT Voltage Range on V_S		-10		10	%
ISOLATION Voltage	1s Flash Test 60s Test, UL1950 ⁽¹⁾	1 1			kVrms kVrms
LINE Regulation			1		%/1% of V_S
SWITCHING/SYNCHRONIZATION Oscillator Frequency (f_{OSC}) Sync Input Low Sync Input Current Disable Time Capacitance Loading on SYNC_{IN} Pin	Switching Frequency = $f_{\text{OSC}}/2$ $V_{\text{SYNC}} = +2\text{V}$ External	0	800 75 2	0.4	kHz V μA μs pF
RELIABILITY Demonstrated	$T_A = +55^\circ\text{C}$			75	FITS
THERMAL SHUTDOWN IC Temperature at Shutdown Shutdown Current			150 3		°C mA
TEMPERATURE RANGE Operating		-40		+100	°C

PRODUCT	INPUT VOLTAGE (V)			OUTPUT VOLTAGE (V)			LOAD REGULATION (%)		NO LOAD CURRENT (mA)	EFFICIENCY (%)	BARRIER CAPACITANCE (pF)
	V_S			V_{NOM}					I_q		C_{ISO}
				75% LOAD ⁽²⁾			10% TO 100% LOAD ⁽³⁾		0% LOAD	100% LOAD	$V_{\text{ISO}} = 750V_{\text{RMS}}$
	MIN	TYP	MAX	MIN	TYP	MAX	TYP	MAX	TYP	TYP	TYP
DCP010505B	4.5	5	5.5	4.75	5	5.25	19	31	20	80	3.6
DCP010505DB	4.5	5	5.5	± 4.25	± 5	± 5.75	18	32	22	81	3.8
DCP010512B	4.5	5	5.5	11.4	12	12.6	21	38	29	85	5.1
DCP010512DB	4.5	5	5.5	± 11.4	± 12	± 12.6	19	37	40	82	4.0
DCP010515B	4.5	5	5.5	14.25	15	15.75	26	42	34	82	3.8
DCP010515DB	4.5	5	5.5	± 14.25	± 15	± 15.75	19	41	42	85	4.7
DCP011512DB	13.5	15	16.5	± 11.4	± 12	± 12.6	11	39	19	78	2.5
DCP011515DB	13.5	15	16.5	± 14.25	± 15	± 15.75	12	39	20	80	2.5
DCP012405B	21.6	24	26.4	4.75	5	5.25	13	23	14	77	2.5
DCP012415DB	21.6	24	26.4	± 4.25	± 5	± 5.75	10	35	17	76	3.8

NOTES: (1) During UL1950 recognition tests only. (2) 100% Load Current = $1W/V_{\text{NOM}}$ TYP. (3) Load regulation = $(V_{\text{OUT}} \text{ at } 10\% \text{ Load} - V_{\text{OUT}} \text{ at } 100\% \text{ Load})/V_{\text{OUT}} \text{ at } 75\% \text{ Load}$.

ABSOLUTE MAXIMUM RATINGS

Input Voltage:	
5V Input Models	7V
15V Input Models	18V
24V Input Models	29V
Storage Temperature	-40°C to +125°C
Lead Temperature (soldering, 10s)	270°C

ORDERING INFORMATION

Basic Model Number: 1W Product	DCP01	05	05	(D)	(B)	()
Voltage Input:						
5V In						
Voltage Output:						
5V Out						
Dual Output:						
Model Revision:						
Package Code:						
P = PDIP-14						
P-U = PDIP-14 Gull-Wing						



ELECTROSTATIC DISCHARGE SENSITIVITY

This integrated circuit can be damaged by ESD. Burr-Brown recommends that all integrated circuits be handled with appropriate precautions. Failure to observe proper handling and installation procedures can cause damage.

ESD damage can range from subtle performance degradation to complete device failure. Precision integrated circuits may be more susceptible to damage because very small parametric changes could cause the device not to meet its published specifications.

PIN CONFIGURATION (Single-DIP and Gull-Wing)

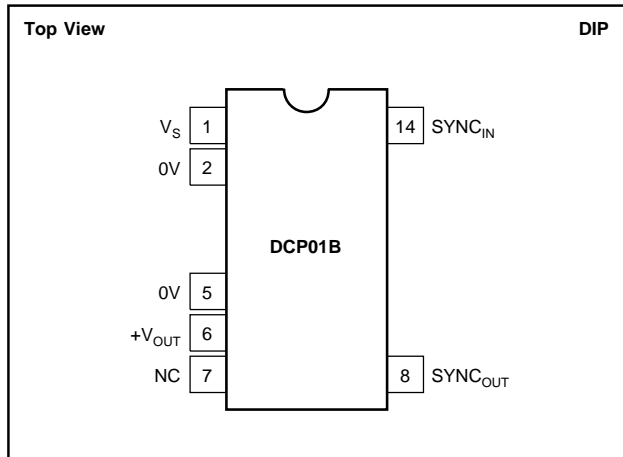

PIN CONFIGURATION (Dual-DIP and Gull-Wing)

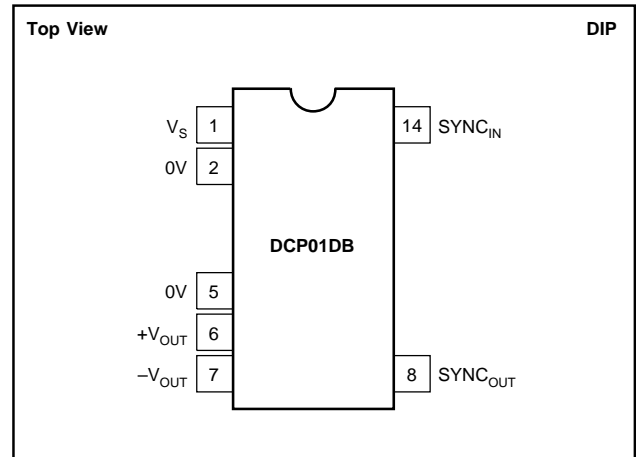

PIN DEFINITION (Single-DIP)

PIN #	PIN NAME	DESCRIPTION
1	V _S	Voltage Input
2	0V	Input Side Common
5	0V	Output Side Common
6	+V _{OUT}	+Voltage Out
7	NC	Not Connected
8	SYNC _{OUT}	Unrectified Transformer Output
14	SYNC _{IN}	Synchronization Pin

PIN DEFINITION (Dual-DIP)

PIN #	PIN NAME	DESCRIPTION
1	V _S	Voltage Input
2	0V	Input Side Common
5	0V	Output Side Common
6	+V _{OUT}	+Voltage Out
7	-V _{OUT}	-Voltage Out
8	SYNC _{OUT}	Unrectified Transformer Output
14	SYNC _{IN}	Synchronization Pin

PACKAGE/ORDERING INFORMATION

PRODUCT	PACKAGE	PACKAGE DRAWING NUMBER	SPECIFIED TEMPERATURE RANGE	PACKAGE MARKING	ORDERING NUMBER ⁽¹⁾	TRANSPORT MEDIA
Single						
DCP010505BP	DIP-14	010-1	-40°C to +100°C	DCP010505BP	DCP010505BP	Rails
DCP010505BP-U	DIP-14 Gull-Wing	010-2	-40°C to +100°C	DCP010505BP-U	DCP010505BP-U/700	Tape and Reel
DCP010512BP	DIP-14	010-1	-40°C to +100°C	DCP010512BP	DCP010512BP	Rails
DCP010512BP-U	DIP-14 Gull-Wing	010-2	-40°C to +100°C	DCP010512BP-U	DCP010512BP-U/700	Tape and Reel
DCP010515BP	DIP-14	010-1	-40°C to +100°C	DCP010515BP	DCP010515BP	Rails
DCP010515BP-U	DIP-14 Gull-Wing	010-2	-40°C to +100°C	DCP010515BP-U	DCP010515BP-U/700	Tape and Reel
DCP012405BP	DIP-14	010-1	-40°C to +100°C	DCP012405BP	DCP012405BP	Rails
DCP012405BP-U	DIP-14 Gull-Wing	010-2	-40°C to +100°C	DCP012405BP-U	DCP012405BP-U/700	Tape and Reel
Dual						
DCP010505DBP	DIP-14	010-1	-40°C to +100°C	DCP010505DBP	DCP010505DBP	Rails
DCP010505DBP-U	DIP-14 Gull-Wing	010-2	-40°C to +100°C	DCP010505DBP-U	DCP010505DBP-U/700	Tape and Reel
DCP010512DBP	DIP-14	010-1	-40°C to +100°C	DCP010512DBP	DCP010512DBP	Rails
DCP010512DBP-U	DIP-14 Gull-Wing	010-2	-40°C to +100°C	DCP010512DBP-U	DCP010512DBP-U/700	Tape and Reel
DCP010515DBP	DIP-14	010-1	-40°C to +100°C	DCP010515DBP	DCP010515DBP	Rails
DCP010515DBP-U	DIP-14 Gull-Wing	010-2	-40°C to +100°C	DCP010515DBP-U	DCP010515DBP-U/700	Tape and Reel
Dual						
DCP011512DBP	DIP-14	010-1	-40°C to +100°C	DCP011512DBP	DCP011512DBP	Rails
DCP011512DBP-U	DIP-14 Gull-Wing	010-2	-40°C to +100°C	DCP011512DBP-U	DCP011512DBP-U/700	Tape and Reel
DCP011515DBP	DIP-14	010-1	-40°C to +100°C	DCP011515DBP	DCP011515DBP	Rails
DCP011515DBP-U	DIP-14 Gull-Wing	010-2	-40°C to +100°C	DCP011515DBP-U	DCP011515DBP-U/700	Tape and Reel
DCP012415DBP	DIP-14	010-1	-40°C to +100°C	DCP012415DBP	DCP012415DBP	Rails
DCP012415DBP-U	DIP-14 Gull-Wing	010-2	-40°C to +100°C	DCP012415DBP-U	DCP012415DBP-U/700	Tape and Reel

NOTE: (1) Models with a slash (/) are available only in Tape and Reel in the quantities indicated (e.g., /700 indicates 700 devices per reel). Ordering 700 pieces of "DCP010505BP-U/700" will get a single 700-piece Tape and Reel.

TYPICAL PERFORMANCE CURVES

At $T_A = +25^\circ\text{C}$, unless otherwise noted.

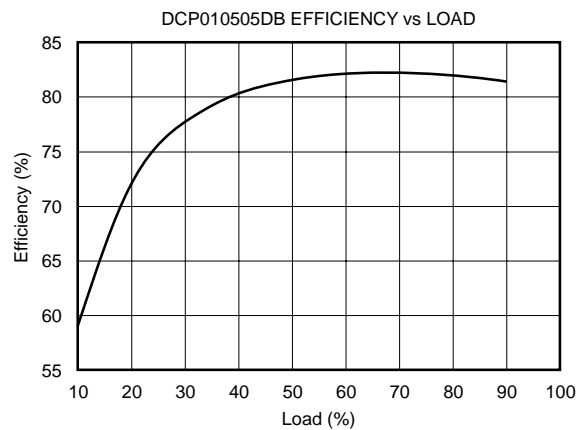
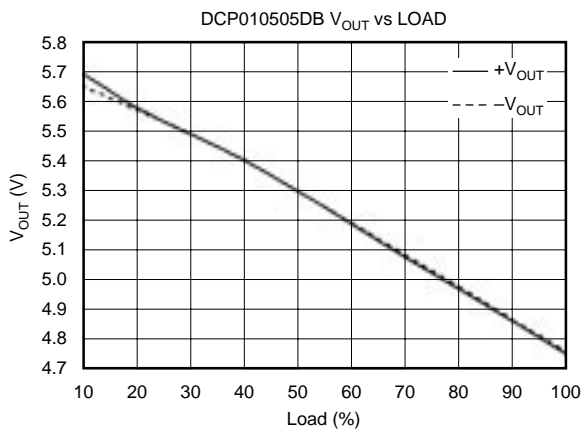
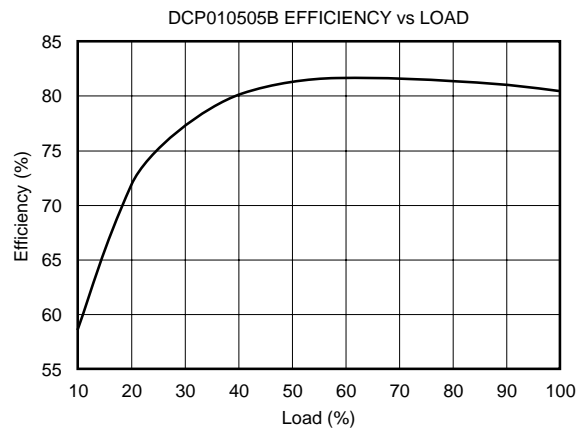
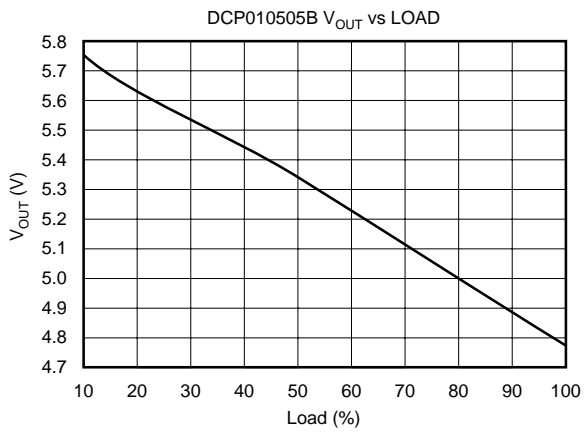
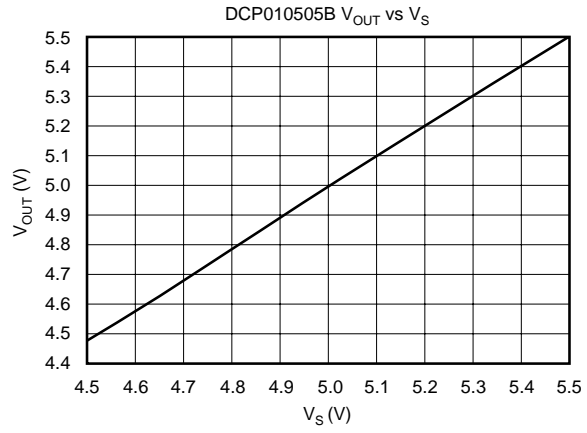
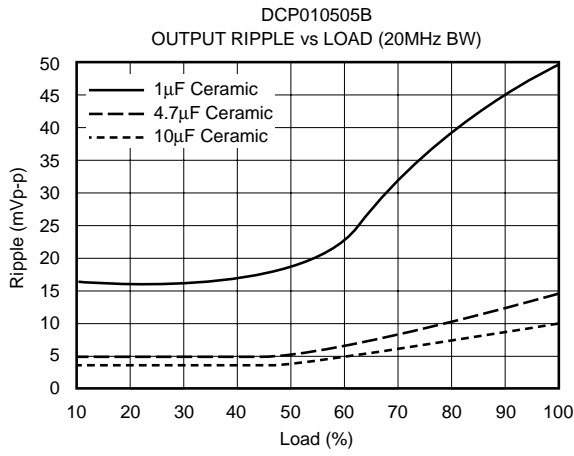

TYPICAL PERFORMANCE CURVES (Cont.)

At $T_A = +25^\circ\text{C}$, unless otherwise noted.

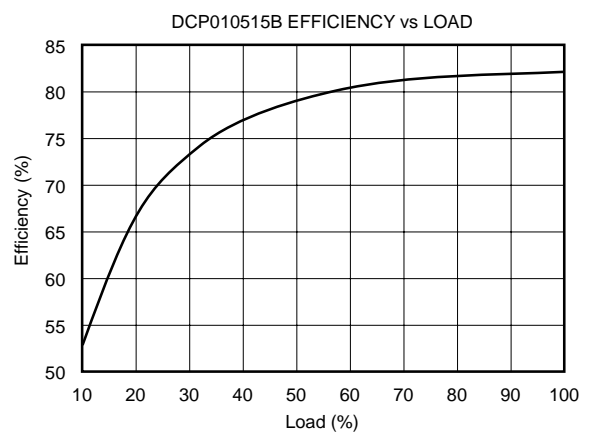
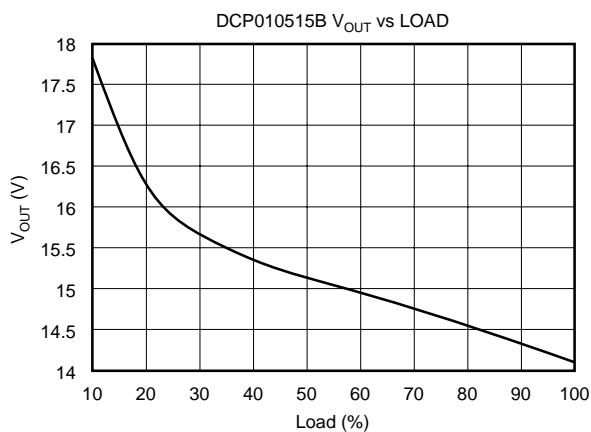
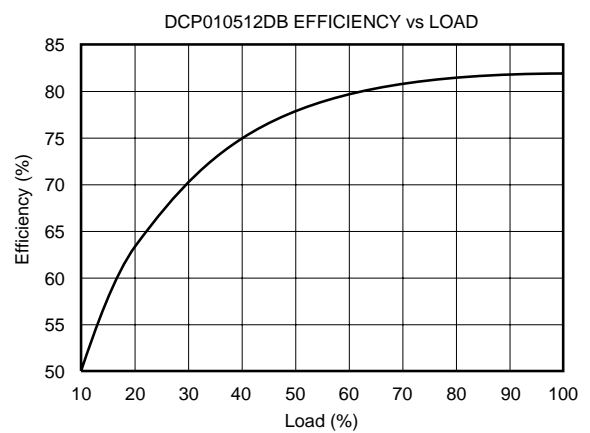
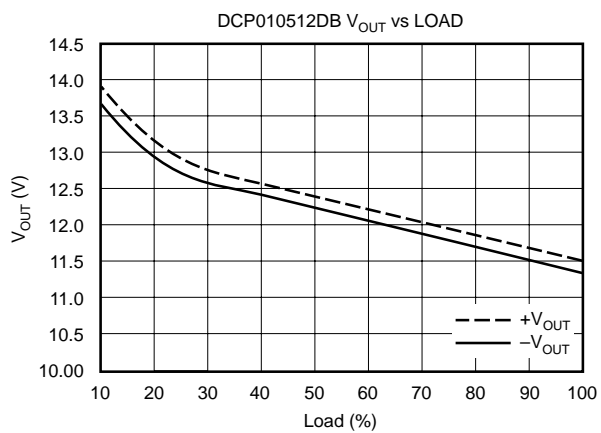
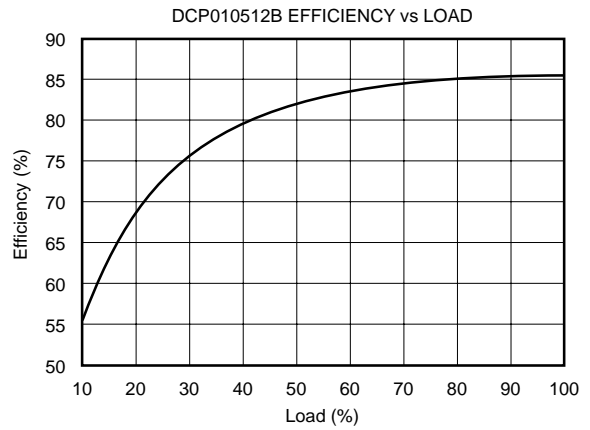
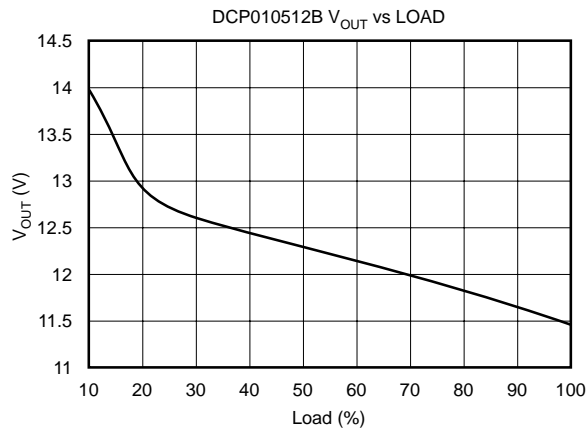

TYPICAL PERFORMANCE CURVES (Cont.)

At $T_A = +25^\circ\text{C}$, unless otherwise noted.

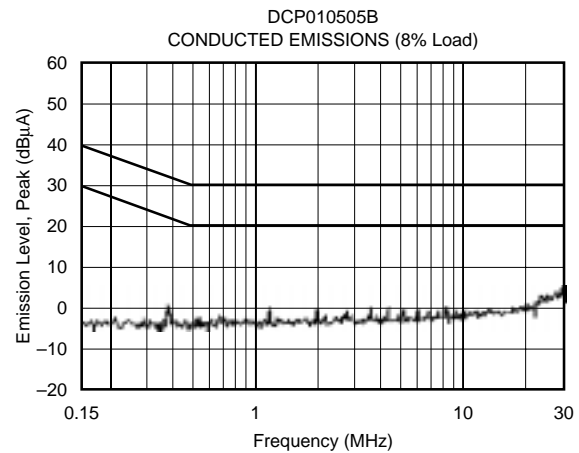
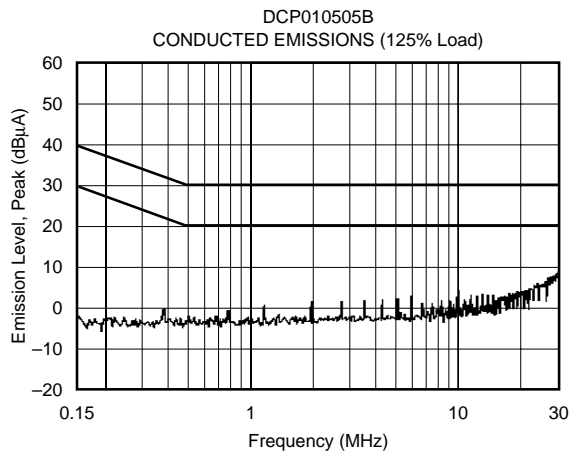
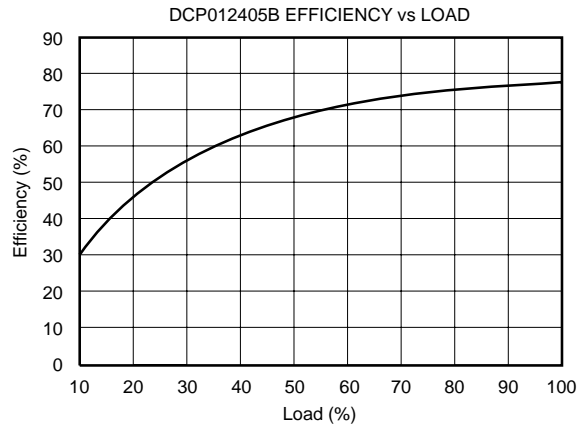
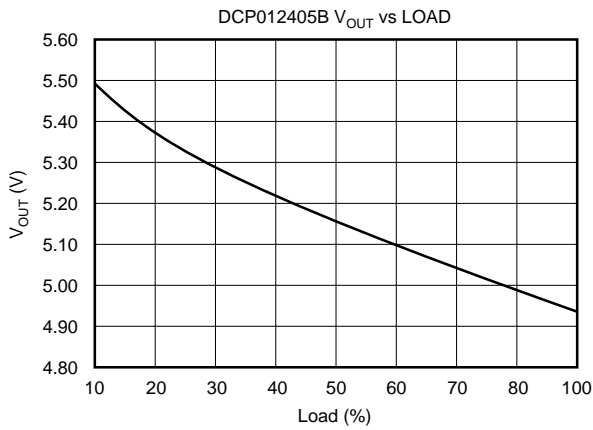
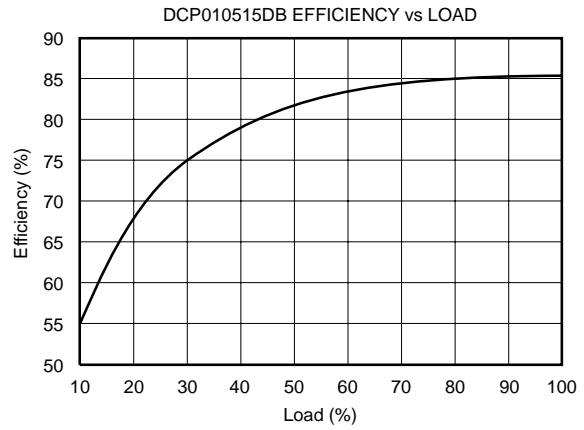
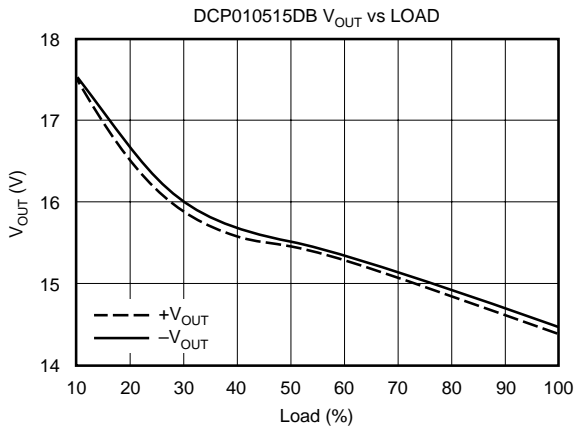

TYPICAL PERFORMANCE CURVES (Cont.)

At $T_A = +25^\circ\text{C}$, unless otherwise noted.

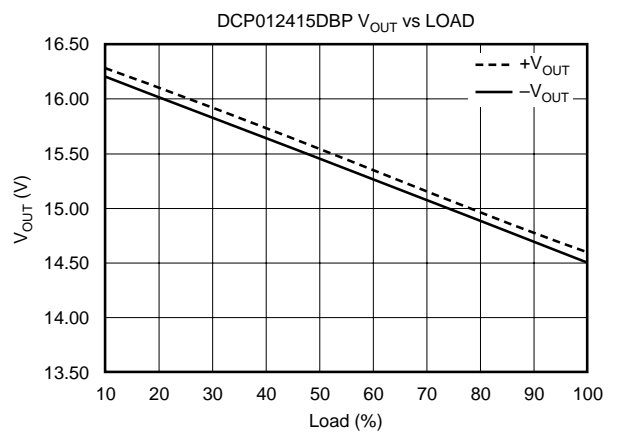
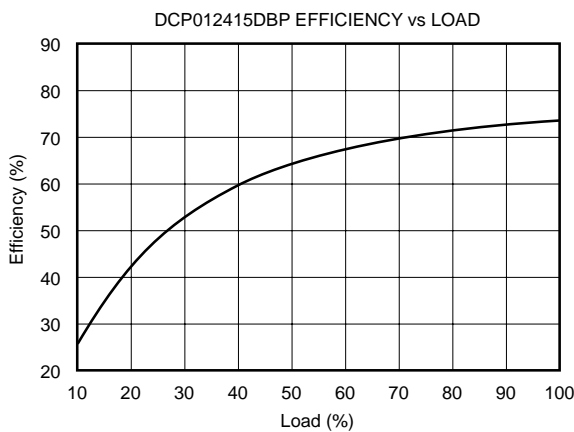
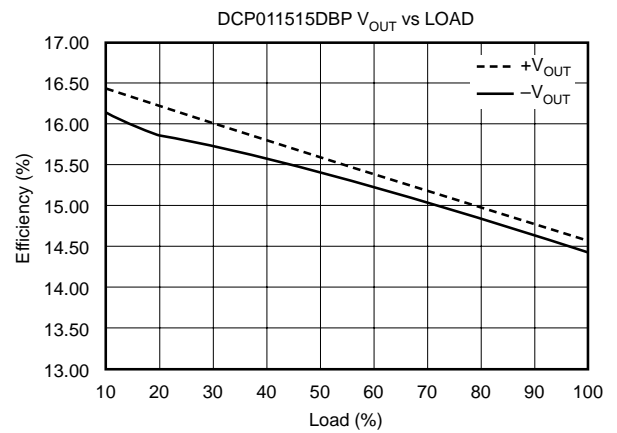
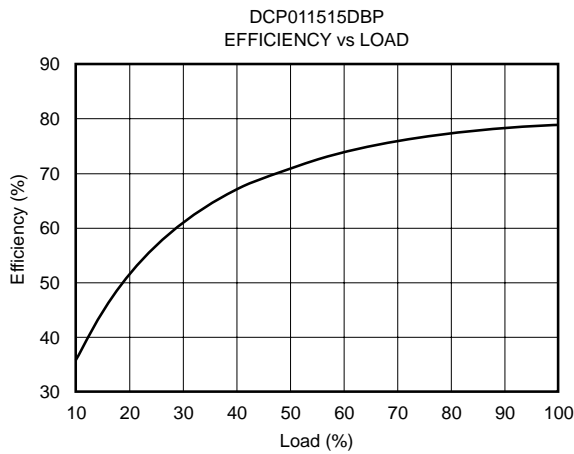
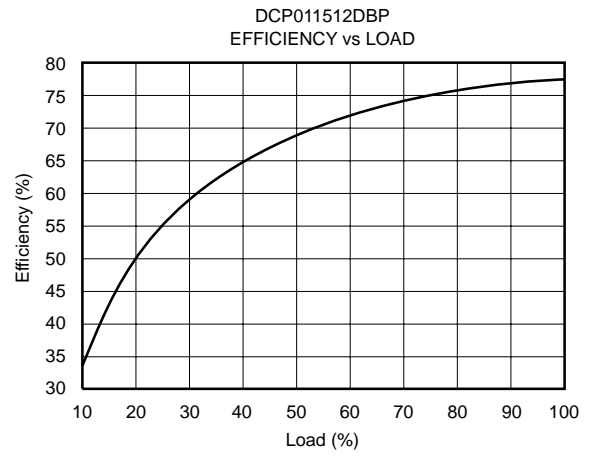
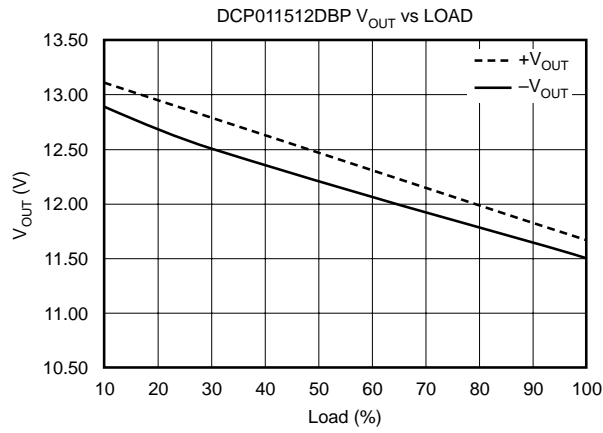

FUNCTIONAL DESCRIPTION

OVERVIEW

The DCP01B offers up to 1W of unregulated output power with a typical efficiency of up to 85%. This is achieved through highly integrated packaging technology and the implementation of a custom power stage and control IC. The circuit design utilizes an advanced BiCMOS/DMOS process.

POWER STAGE

This uses a push-pull, center-tapped topology switching at 400kHz (divide by 2 from 800kHz oscillator).

OSCILLATOR AND WATCHDOG

The onboard 800kHz oscillator generates the switching frequency via a divide by 2 circuit. The oscillator can be synchronized to other DCP01B circuits or an external source, and is used to minimize system noise.

A watchdog circuit checks the operation of the oscillator circuit. The oscillator can be stopped by pulling the SYNC pin LOW. The output pins will be tri-stated. This will occur in 2 μ s.

THERMAL SHUTDOWN

The DCP01B is protected by a thermal shutdown circuit. If the on-chip temperature exceeds 150°C, the device will shut down. Once the temperature falls below 150°C, normal operation will resume.

SYNCHRONIZATION

In the event that more than one DC/DC converter is needed onboard, beat frequencies and other electrical interference can be generated. This is due to the small variations in switching frequencies between the DC/DC converters.

The DCP01B overcomes this by allowing devices to be synchronized to one another. Up to eight devices can be synchronized by connecting the SYNC_{IN} pins together, taking care to minimize the capacitance of tracking. Stray capacitance (> 3pF) will have the effect of reducing the switching frequency, or even stopping the oscillator circuit.

If synchronized devices are used, it should be noted that, at start up, all devices will draw maximum current simultaneously. This can cause the input voltage to dip and should it dip below the minimum input voltage (4.5V), the devices may not start up. A 2.2 μ F capacitor should be connected close to the input pins.

If more than eight devices are to be synchronized, it is recommended that the SYNC_{IN} pins are driven by an external device. Details are contained in a separate applications bulletin (AB-153).

CONSTRUCTION

The DCP01B's basic construction is the same as standard ICs. There is no substrate within the molded package. The DCP01B is constructed using an IC, rectifier diodes, and a wound magnetic toroid on a leadframe. As there is no solder within the package, the DCP01B does not require any special PCB assembly processing. This results in an isolated DC/DC converter with inherently high reliability.

ADDITIONAL FUNCTIONS

DISABLE/ENABLE

The DCP01B can be disabled or enabled by driving the SYNC pin using an open drain CMOS gate. If the SYNC_{IN} pin is pulled low, the DCP01B will be disabled. The disable time depends upon the external loading; the internal disable function is implemented in 2 μ s. Removal of the pull down will cause the DCP01B to be enabled.

Capacitive loading on the SYNC_{IN} pin should be minimized in order to prevent a reduction in the oscillator frequency.

DECOUPLING

Ripple Reduction

The high switching frequency of 400kHz allows simple filtering. To reduce ripple, it is recommended that at least a 1 μ F capacitor is used on V_{OUT}. Dual outputs should both be decoupled to pin 5. A 2.2 μ F low ESR capacitor on the input of the 5V in versions, and a 0.47 μ F low ESR cap on the 24V DCP01B in versions is recommended.

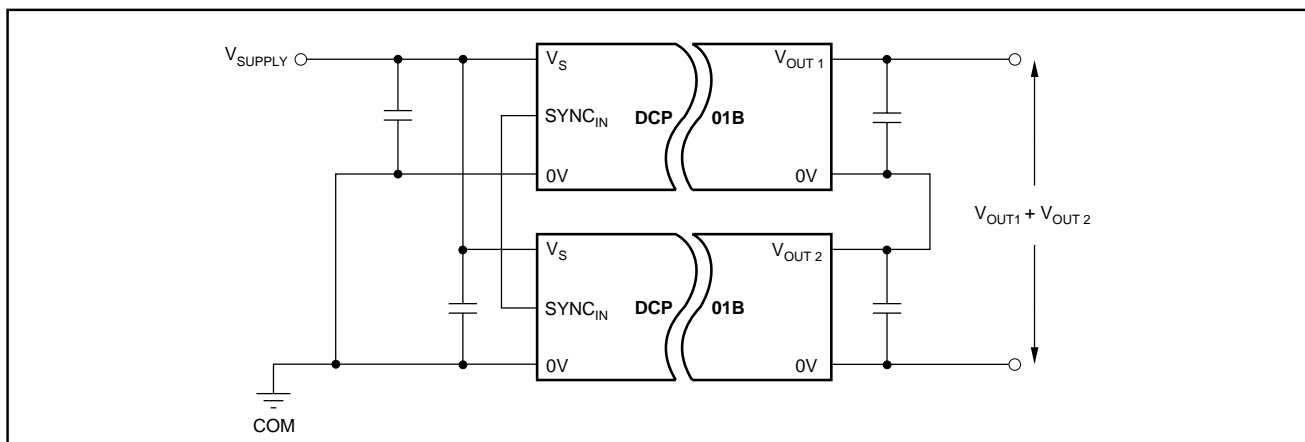

FIGURE 1. Connecting the DCP01B in Series.

Connecting the DCP01B in Series

Multiple DCP01B isolated 1W DC/DC converters can be connected in series to provide nonstandard voltage rails. This is possible by utilizing the floating outputs provided by the DCP01B's galvanic isolation.

Connect the positive V_{OUT} from one DCP01B to the negative V_{OUT} (0V) of another (see Figure 1). If the $SYNC_{IN}$ pins are tied together, the self-synchronization feature of the DCP01B will prevent beat frequencies on the voltage rails. The $SYNC_{IN}$ feature of the DCP01B allows easy series connection without external filtering, minimizing cost.

The outputs on dual output DCP01B versions can also be connected in series to provide two times the magnitude of V_{OUT} as shown in Figure 2. For example, a dual 15V DCP01B could be connected to provide a 30V rail.

Connecting the DCP01B in Parallel

If the output power from one DCP01B is not sufficient, it is possible to parallel the outputs of multiple DCP01Bs, as shown in Figure 3. Again, the $SYNC_{IN}$ feature allows easy synchronization to prevent power-rail beat frequencies at no additional filtering cost.

PCB LAYOUT

Ripple and Noise

Careful consideration should be given to the layout of the PCB in order that the best results can be obtained.

The DCP01B is a switching power supply and as such can place high peak current demands on the input supply. In order to avoid the supply falling momentarily during the fast switching pulses ground and power planes should be used to track the power to the input of DCP01B. If this is not possible then the supplies must be connected in a star formation with the tracks made as wide as possible.

If the $SYNC_{IN}$ pin is being used then the tracking between device $SYNC_{IN}$ pins should be short to avoid stray capacitance. If the $SYNC_{IN}$ pin is not being used it is advisable to place a guard ring, (connected to input ground) around this pin to avoid any noise pick up.

The output should be taken from the device using ground and power planes, this will ensure minimum losses.

A good quality low ESR capacitor placed as close as practicable across the input will reduce reflected ripple and ensure a smooth start up.

A good quality low ESR capacitor placed as close as practicable across the rectifier output terminal and output ground will give the best ripple and noise performance.

THERMAL MANAGEMENT

Due to the high power density of this device it is advisable to provide ground planes on the input and output.

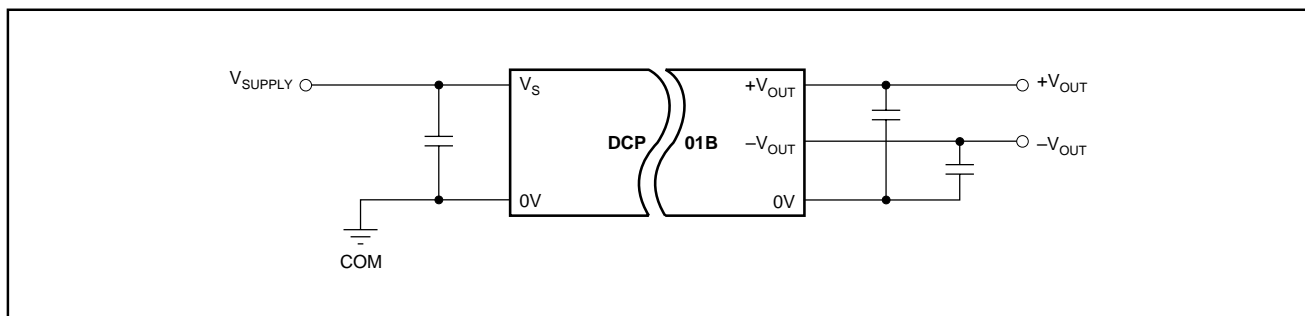

FIGURE 2. Connecting Dual Outputs in Series.

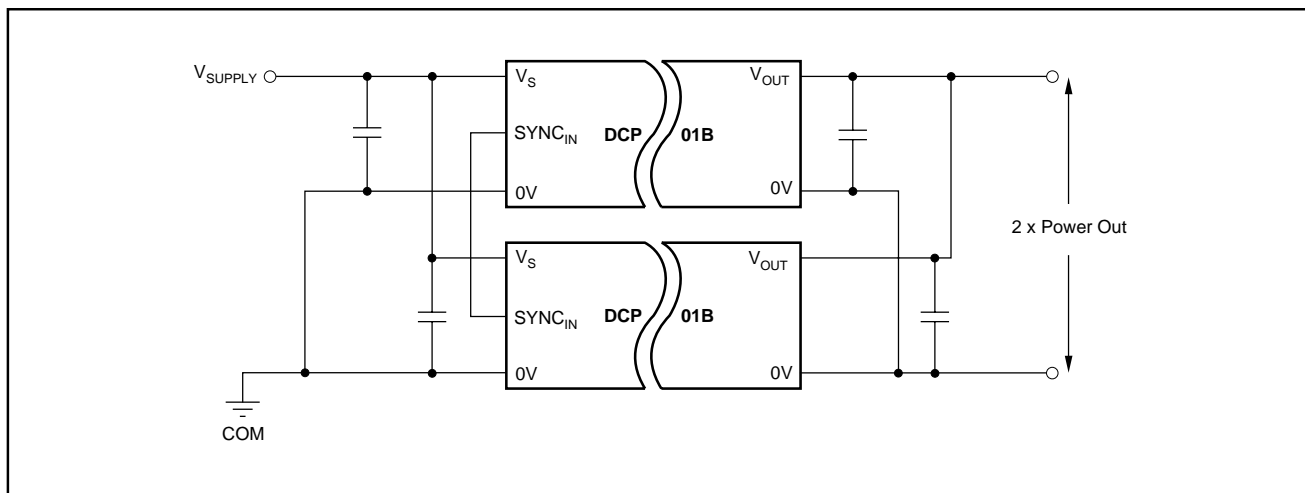

FIGURE 3. Connecting Multiple DCP01Bs in Parallel.

PACKAGING INFORMATION

Orderable Device	Status ⁽¹⁾	Package Type	Package Drawing	Pins	Package Qty	Eco Plan ⁽²⁾	Lead/Ball Finish	MSL Peak Temp ⁽³⁾
DCP010505BP	ACTIVE	PDIP	NVA	7	25	Pb-Free (RoHS)	Call TI	N / A for Pkg Type
DCP010505BP-U	ACTIVE	SOP	DUA	7	25	Pb-Free (RoHS)	Call TI	Level-3-260C-168 HR
DCP010505BP-U/700	ACTIVE	SOP	DUA	7	700	Pb-Free (RoHS)	Call TI	Level-3-260C-168 HR
DCP010505BP-U/7E4	ACTIVE	SOP	DUA	7	700	Pb-Free (RoHS)	Call TI	Level-3-260C-168 HR
DCP010505BP-UE4	ACTIVE	SOP	DUA	7	25	Pb-Free (RoHS)	Call TI	Level-3-260C-168 HR
DCP010505DBP	ACTIVE	PDIP	NVA	7	25	Pb-Free (RoHS)	CU NIPDAU	N / A for Pkg Type
DCP010505DBP-U	ACTIVE	SOP	DUA	7	25	Pb-Free (RoHS)	CU NIPDAU	Level-3-260C-168 HR
DCP010505DBP-U/700	ACTIVE	SOP	DUA	7	700	Pb-Free (RoHS)	CU NIPDAU	Level-3-260C-168 HR
DCP010505DBP-U/7E4	ACTIVE	SOP	DUA	7	700	Pb-Free (RoHS)	CU NIPDAU	Level-3-260C-168 HR
DCP010505DBP-UE4	ACTIVE	SOP	DUA	7	25	Pb-Free (RoHS)	CU NIPDAU	Level-3-260C-168 HR
DCP010512BP	ACTIVE	PDIP	NVA	7	25	Pb-Free (RoHS)	CU NIPDAU	N / A for Pkg Type
DCP010512BP-U	ACTIVE	SOP	DUA	7	25	TBD	CU NIPDAU	Level-3-240C-168 HR
DCP010512BP-U/700	ACTIVE	SOP	DUA	7	700	Pb-Free (RoHS)	CU NIPDAU	Level-3-260C-168 HR
DCP010512DBP	ACTIVE	PDIP	NVA	7	25	Pb-Free (RoHS)	CU NIPDAU	N / A for Pkg Type
DCP010512DBP-U	ACTIVE	SOP	DUA	7	25	TBD	CU NIPDAU	Level-3-240C-168 HR
DCP010512DBP-U/700	ACTIVE	SOP	DUA	7	700	TBD	CU NIPDAU	Level-3-240C-168 HR
DCP010512DBPE4	ACTIVE	PDIP	NVA	7	25	Pb-Free (RoHS)	CU NIPDAU	N / A for Pkg Type
DCP010515BP	ACTIVE	PDIP	NVA	7	25	Pb-Free (RoHS)	CU NIPDAU	N / A for Pkg Type
DCP010515BP-U	ACTIVE	SOP	DUA	7	25	Pb-Free (RoHS)	CU NIPDAU	Level-3-260C-168 HR
DCP010515BP-U/700	ACTIVE	SOP	DUA	7	700	TBD	CU NIPDAU	Level-3-240C-168 HR
DCP010515DBP	ACTIVE	PDIP	NVA	7	25	Pb-Free (RoHS)	CU NIPDAU	N / A for Pkg Type
DCP010515DBP-U	ACTIVE	SOP	DUA	7	25	Pb-Free (RoHS)	CU NIPDAU	Level-3-260C-168 HR
DCP010515DBP-U/700	ACTIVE	SOP	DUA	7	700	Pb-Free (RoHS)	CU NIPDAU	Level-3-260C-168 HR
DCP011512DBP	ACTIVE	PDIP	NVA	7	25	Pb-Free (RoHS)	CU NIPDAU	N / A for Pkg Type
DCP011512DBP-U	ACTIVE	SOP	DUA	7	25	Pb-Free (RoHS)	CU NIPDAU	Level-3-260C-168 HR
DCP011512DBP-U/700	ACTIVE	SOP	DUA	7	700	TBD	CU NIPDAU	Level-3-240C-168 HR
DCP011515DBP	ACTIVE	PDIP	NVA	7	25	Pb-Free (RoHS)	CU NIPDAU	N / A for Pkg Type

Orderable Device	Status ⁽¹⁾	Package Type	Package Drawing	Pins	Package Qty	Eco Plan ⁽²⁾	Lead/Ball Finish	MSL Peak Temp ⁽³⁾
DCP011515DBP-U	ACTIVE	SOP	DUA	7	25	Pb-Free (RoHS)	CU NIPDAU	Level-3-260C-168 HR
DCP011515DBP-U/700	ACTIVE	SOP	DUA	7	700	Pb-Free (RoHS)	CU NIPDAU	Level-3-260C-168 HR
DCP012405BP	ACTIVE	PDIP	NVA	7	25	TBD	CU NIPDAU	N / A for Pkg Type
DCP012405BP-U	ACTIVE	SOP	DUA	7	25	Pb-Free (RoHS)	CU NIPDAU	Level-3-260C-168 HR
DCP012405BP-U/700	ACTIVE	SOP	DUA	7	700	Pb-Free (RoHS)	CU NIPDAU	Level-3-260C-168 HR
DCP012405BP-U/7E4	ACTIVE	SOP	DUA	7	700	Pb-Free (RoHS)	CU NIPDAU	Level-3-260C-168 HR
DCP012415DBP	ACTIVE	PDIP	NVA	7	25	Pb-Free (RoHS)	CU NIPDAU	N / A for Pkg Type
DCP012415DBP-U	ACTIVE	SOP	DUA	7	25	Pb-Free (RoHS)	CU NIPDAU	Level-3-260C-168 HR
DCP012415DBP-U/700	ACTIVE	SOP	DUA	7	700	Pb-Free (RoHS)	CU NIPDAU	Level-3-260C-168 HR

⁽¹⁾ The marketing status values are defined as follows:

ACTIVE: Product device recommended for new designs.

LIFEBUY: TI has announced that the device will be discontinued, and a lifetime-buy period is in effect.

NRND: Not recommended for new designs. Device is in production to support existing customers, but TI does not recommend using this part in a new design.

PREVIEW: Device has been announced but is not in production. Samples may or may not be available.

OBSOLETE: TI has discontinued the production of the device.

⁽²⁾ Eco Plan - The planned eco-friendly classification: Pb-Free (RoHS), Pb-Free (RoHS Exempt), or Green (RoHS & no Sb/Br) - please check <http://www.ti.com/productcontent> for the latest availability information and additional product content details.

TBD: The Pb-Free/Green conversion plan has not been defined.

Pb-Free (RoHS): TI's terms "Lead-Free" or "Pb-Free" mean semiconductor products that are compatible with the current RoHS requirements for all 6 substances, including the requirement that lead not exceed 0.1% by weight in homogeneous materials. Where designed to be soldered at high temperatures, TI Pb-Free products are suitable for use in specified lead-free processes.

Pb-Free (RoHS Exempt): This component has a RoHS exemption for either 1) lead-based flip-chip solder bumps used between the die and package, or 2) lead-based die adhesive used between the die and leadframe. The component is otherwise considered Pb-Free (RoHS compatible) as defined above.

Green (RoHS & no Sb/Br): TI defines "Green" to mean Pb-Free (RoHS compatible), and free of Bromine (Br) and Antimony (Sb) based flame retardants (Br or Sb do not exceed 0.1% by weight in homogeneous material)

⁽³⁾ MSL, Peak Temp. -- The Moisture Sensitivity Level rating according to the JEDEC industry standard classifications, and peak solder temperature.

Important Information and Disclaimer: The information provided on this page represents TI's knowledge and belief as of the date that it is provided. TI bases its knowledge and belief on information provided by third parties, and makes no representation or warranty as to the accuracy of such information. Efforts are underway to better integrate information from third parties. TI has taken and continues to take reasonable steps to provide representative and accurate information but may not have conducted destructive testing or chemical analysis on incoming materials and chemicals. TI and TI suppliers consider certain information to be proprietary, and thus CAS numbers and other limited information may not be available for release.

In no event shall TI's liability arising out of such information exceed the total purchase price of the TI part(s) at issue in this document sold by TI to Customer on an annual basis.

IMPORTANT NOTICE

Texas Instruments Incorporated and its subsidiaries (TI) reserve the right to make corrections, modifications, enhancements, improvements, and other changes to its products and services at any time and to discontinue any product or service without notice. Customers should obtain the latest relevant information before placing orders and should verify that such information is current and complete. All products are sold subject to TI's terms and conditions of sale supplied at the time of order acknowledgment.

TI warrants performance of its hardware products to the specifications applicable at the time of sale in accordance with TI's standard warranty. Testing and other quality control techniques are used to the extent TI deems necessary to support this warranty. Except where mandated by government requirements, testing of all parameters of each product is not necessarily performed.

TI assumes no liability for applications assistance or customer product design. Customers are responsible for their products and applications using TI components. To minimize the risks associated with customer products and applications, customers should provide adequate design and operating safeguards.

TI does not warrant or represent that any license, either express or implied, is granted under any TI patent right, copyright, mask work right, or other TI intellectual property right relating to any combination, machine, or process in which TI products or services are used. Information published by TI regarding third-party products or services does not constitute a license from TI to use such products or services or a warranty or endorsement thereof. Use of such information may require a license from a third party under the patents or other intellectual property of the third party, or a license from TI under the patents or other intellectual property of TI.

Reproduction of information in TI data books or data sheets is permissible only if reproduction is without alteration and is accompanied by all associated warranties, conditions, limitations, and notices. Reproduction of this information with alteration is an unfair and deceptive business practice. TI is not responsible or liable for such altered documentation.

Resale of TI products or services with statements different from or beyond the parameters stated by TI for that product or service voids all express and any implied warranties for the associated TI product or service and is an unfair and deceptive business practice. TI is not responsible or liable for any such statements.

Following are URLs where you can obtain information on other Texas Instruments products and application solutions:

Products

Amplifiers	amplifier.ti.com
Data Converters	dataconverter.ti.com
DSP	dsp.ti.com
Interface	interface.ti.com
Logic	logic.ti.com
Power Mgmt	power.ti.com
Microcontrollers	microcontroller.ti.com
Low Power Wireless	www.ti.com/lpw

Applications

Audio	www.ti.com/audio
Automotive	www.ti.com/automotive
Broadband	www.ti.com/broadband
Digital Control	www.ti.com/digitalcontrol
Military	www.ti.com/military
Optical Networking	www.ti.com/opticalnetwork
Security	www.ti.com/security
Telephony	www.ti.com/telephony
Video & Imaging	www.ti.com/video
Wireless	www.ti.com/wireless

Mailing Address: Texas Instruments
Post Office Box 655303 Dallas, Texas 75265