



## 12-Bit, Parallel Input, Multiplying Digital-to-Analog Converter

### FEATURES

- 2.5V to 5.5V Supply Operation
- Fast Parallel Interface:  
17ns Write Cycle
- Update Rate of 20.4MSPS
- 10MHz Multiplying Bandwidth
- $\pm 10V$  Reference Input
- Low Glitch Energy: 5nV-s
- Extended Temperature Range:  
 $-40^{\circ}C$  to  $+125^{\circ}C$
- 20-Lead TSSOP Packages
- 12-Bit Monotonic
- $\pm 1LSB$  INL
- 4-Quadrant Multiplication
- Power-On Reset with Brownout Detection
- Readback Function
- Industry-Standard Pin Configuration

### APPLICATIONS

- Portable Battery-Powered Instruments
- Waveform Generators
- Analog Processing
- Programmable Amplifiers and Attenuators
- Digitally-Controlled Calibration
- Programmable Filters and Oscillators
- Composite Video
- Ultrasound

### DESCRIPTION

The DAC7821 is a CMOS 12-bit current output digital-to-analog converter (DAC). This device operates from a single 2.5V to 5.5V power supply, making it suitable for battery-powered and many other applications.

This DAC operates with a fast parallel interface. Data readback allows the user to read the contents of the DAC register via the DB pins. On power-up, the internal register and latches are filled with zeroes and the DAC outputs are at zero scale.

The DAC7821 offers excellent 4-quadrant multiplication characteristics, with a large signal multiplying bandwidth of 10MHz. The applied external reference input voltage ( $V_{REF}$ ) determines the full-scale output current. An integrated feedback resistor ( $R_{FB}$ ) provides temperature tracking and full-scale voltage output when combined with an external current-to-voltage precision amplifier.

The DAC7821 is available in a 20-lead TSSOP package.

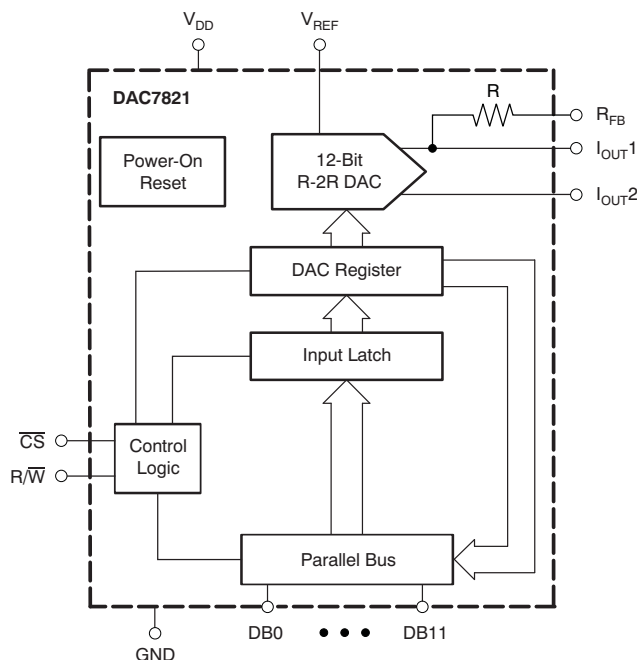

Please be aware that an important notice concerning availability, standard warranty, and use in critical applications of Texas Instruments semiconductor products and disclaimers thereto appears at the end of this data sheet.

All trademarks are the property of their respective owners.



This integrated circuit can be damaged by ESD. Texas Instruments recommends that all integrated circuits be handled with appropriate precautions. Failure to observe proper handling and installation procedures can cause damage.

ESD damage can range from subtle performance degradation to complete device failure. Precision integrated circuits may be more susceptible to damage because very small parametric changes could cause the device not to meet its published specifications.

## PACKAGE/ORDERING INFORMATION

For the most current package and ordering information, see the Package Option Addendum at the end of this document, or see the TI website at [www.ti.com](http://www.ti.com).

## ABSOLUTE MAXIMUM RATINGS

over operating free-air temperature range (unless otherwise noted)<sup>(1)</sup>

	DAC7821	UNIT
$V_{DD}$ to GND	–0.3 to +7	V
Digital input voltage to GND	–0.3 to $V_{DD} + 0.3$	V
$V_{(I/O)}$ to GND	–0.3 to $V_{DD} + 0.3$	V
Operating temperature range	–40 to +125	°C
Storage temperature range	–65 to +150	°C
Junction temperature ( $T_J$ max)	+150	°C
ESD Rating, HBM	3000	V
ESD Rating, CDM	1000	V

(1) Stresses above those listed under absolute maximum ratings may cause permanent damage to the device. Exposure to absolute maximum conditions for extended periods may affect device reliability.

**ELECTRICAL CHARACTERISTICS**

$V_{DD} = +2.5V$  to  $+5.5V$ ;  $I_{OUT1} = \text{Virtual GND}$ ;  $I_{OUT2} = 0V$ ;  $V_{REF} = +10V$ ;  $T_A = \text{full operating temperature}$ . All specifications  $-40^\circ\text{C}$  to  $+125^\circ\text{C}$ , unless otherwise noted.

PARAMETER	CONDITIONS	DAC7821			UNITS
		MIN	TYP	MAX	
<b>STATIC PERFORMANCE</b>					
Resolution		12			Bits
Relative accuracy				$\pm 1$	LSB
Differential nonlinearity				$\pm 1$	LSB
Output leakage current	Data = 000h, $T_A = +25^\circ\text{C}$			$\pm 10$	nA
Output leakage current	Data = 000h, $T_A = T_{MAX}$			$\pm 20$	nA
Full-scale gain error	All is loaded to DAC register		$\pm 5$	$\pm 10$	mV
Full-scale tempco			$\pm 5$		ppm/ $^\circ\text{C}$
Output capacitance	Code dependent		30		pF
<b>REFERENCE INPUT</b>					
$V_{REF}$ range		-15		15	V
Input resistance		8	10	12	k $\Omega$
$R_{FB}$ resistance		8	10	12	k $\Omega$
<b>LOGIC INPUTS AND OUTPUT<sup>(1)</sup></b>					
Input low voltage	$V_{IL}$ $V_{DD} = +2.7V$			0.6	V
	$V_{IL}$ $V_{DD} = +5V$			0.8	V
Input high voltage	$V_{IH}$ $V_{DD} = +2.7V$	2.1			V
	$V_{IH}$ $V_{DD} = +5V$	2.4			V
Input leakage current	$I_{IL}$			10	$\mu\text{A}$
Input capacitance	$C_{IL}$			10	pF
<b>POWER REQUIREMENTS</b>					
$V_{DD}$		2.7		5.5	V
$I_{DD}$ (normal operation)	Logic inputs = 0V			5	$\mu\text{A}$
$V_{DD} = +4.5V$ to $+5.5V$	$V_{IH} = V_{DD}$ and $V_{IL} = \text{GND}$		0.8	5	$\mu\text{A}$
$V_{DD} = +2.5V$ to $+3.6V$	$V_{IH} = V_{DD}$ and $V_{IL} = \text{GND}$		0.4	2.5	$\mu\text{A}$
<b>AC CHARACTERISTICS</b>					
Output voltage settling time				0.2	$\mu\text{s}$
Reference multiplying BW	$V_{REF} = 7V_{PP}$ , Data = FFFh		10		MHz
DAC glitch impulse	$V_{REF} = 0V$ to $10V$ , Data = 7FFh to 800h to 7FFh		5		nV-s
Feedthrough error $V_{OUT}/V_{REF}$	Data = 000h, $V_{REF} = 100\text{kHz}$		-70		dB
Digital feedthrough			2		nV-s
Total harmonic distortion			-105		dB
Output spot noise voltage			18		$\text{nV}/\sqrt{\text{Hz}}$

(1) Specified by design and characterization; not production tested.

TIMING INFORMATION

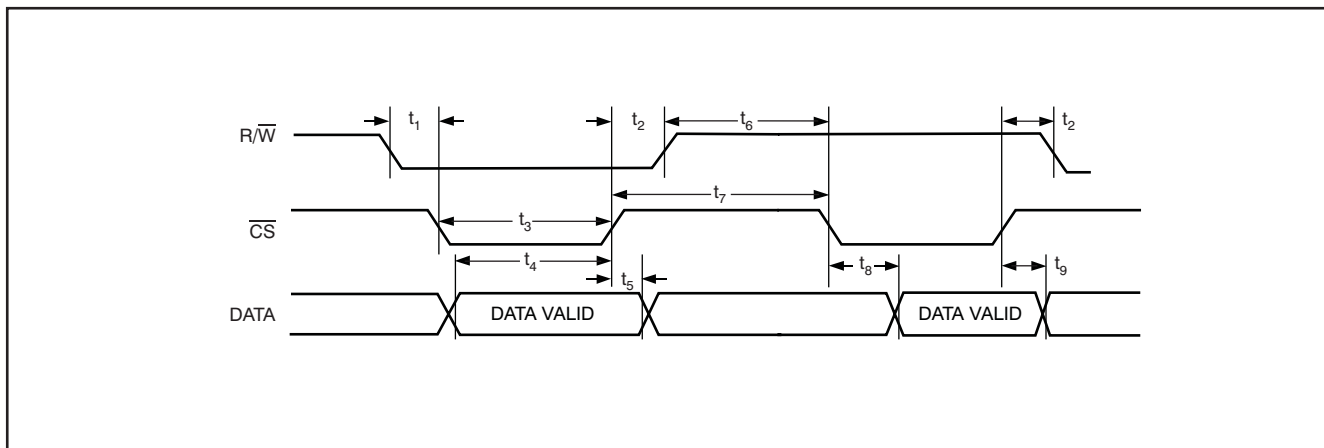

**TIMING REQUIREMENTS: 2.5 V to 4.5 V**

At  $t_r = t_f = 1\text{ns}$  (10% to 90% of  $V_{DD}$ ) and timed from a voltage level of  $(V_{IL} + V_{IH})/2$ ;  $V_{DD} = +2.5\text{V}$  to  $+4.5\text{V}$ ,  $V_{REF} = +10\text{V}$ ,  $I_{OUT2} = 0\text{V}$ . All specifications  $-40^\circ\text{C}$  to  $+125^\circ\text{C}$ , unless otherwise noted.

PARAMETER <sup>(1)</sup>	TEST CONDITIONS	DAC7821			UNIT
		MIN	TYP	MAX	
$t_1$	R/W to CS setup time	0			ns
$t_2$	R/W to CS hold time	0			ns
$t_3$	CS low time (write cycle)	10			ns
$t_4$	Data setup time	6			ns
$t_5$	Data hold time	0			ns
$t_6$	R/W high to CS low	5			ns
$t_7$	CS min high time	9			ns
$t_8$	Data access time		20	40	ns
$t_9$	Bus relinquish time		5	10	ns

(1) Ensured by design; not production tested.

**TIMING REQUIREMENTS: 4.5 V to 5.5 V**

At  $t_r = t_f = 1\text{ns}$  (10% to 90% of  $V_{DD}$ ) and timed from a voltage level of  $(V_{IL} + V_{IH})/2$ ;  $V_{DD} = +4.5\text{V}$  to  $+5.5\text{V}$ ,  $V_{REF} = +10\text{V}$ ,  $I_{OUT2} = 0\text{V}$ . All specifications  $-40^\circ\text{C}$  to  $+125^\circ\text{C}$ , unless otherwise noted.

PARAMETER <sup>(1)</sup>	TEST CONDITIONS	DAC7821			UNIT
		MIN	TYP	MAX	
$t_1$	R/W to CS setup time	0			ns
$t_2$	R/W to CS hold time	0			ns
$t_3$	CS low time (write cycle)	10			ns
$t_4$	Data setup time	6			ns
$t_5$	Data hold time	0			ns
$t_6$	R/W high to CS low	5			ns
$t_7$	CS min high time	7			ns
$t_8$	Data access time		10	20	ns
$t_9$	Bus relinquish time		5	10	ns

(1) Ensured by design; not production tested.

## DEVICE INFORMATION

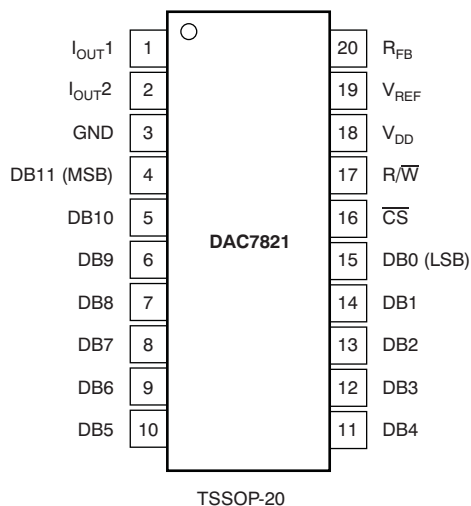

## TERMINAL FUNCTIONS

TERMINAL		DESCRIPTION
TSSOP NO.	NAME	
1	$I_{OUT1}$	DAC current output.
2	$I_{OUT2}$	DAC analog ground. This pin is normally tied to the analog ground of the system.
3	GND	Ground pin.
4–15	DB11 – DB0	Parallel data bits 11 to 0.
16	$\overline{CS}$	Chip select input. Active low. Used in conjunction with $R/\overline{W}$ to load parallel data to the input latch or read data from the DAC register. Rising edge of $\overline{CS}$ loads data.
17	$R/\overline{W}$	Read/Write. When low, use in conjunction with $\overline{CS}$ to load parallel data. When high, use with $\overline{CS}$ to read back contents of DAC register.
18	$V_{DD}$	Positive power supply input. These parts can be operated from a supply of 2.5V to 5.5V.
19	$V_{REF}$	DAC reference voltage input.
20	$R_{FB}$	DAC feedback resistor pin. Establish voltage output for the DAC by connecting to external amplifier output.

**TYPICAL CHARACTERISTICS:  $V_{DD} = +5V$**

At  $T_A = +25^\circ C$ , unless otherwise noted.

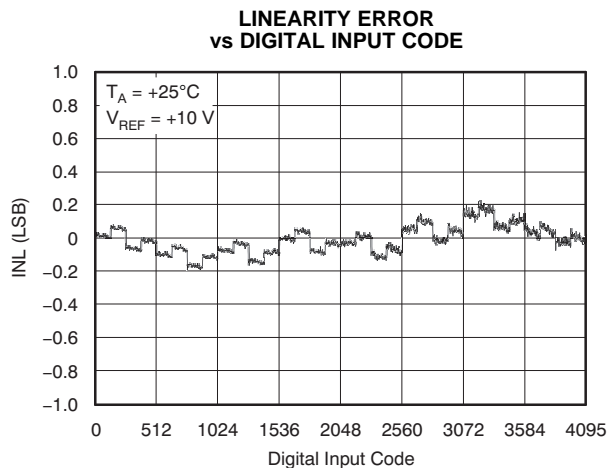

Figure 1.

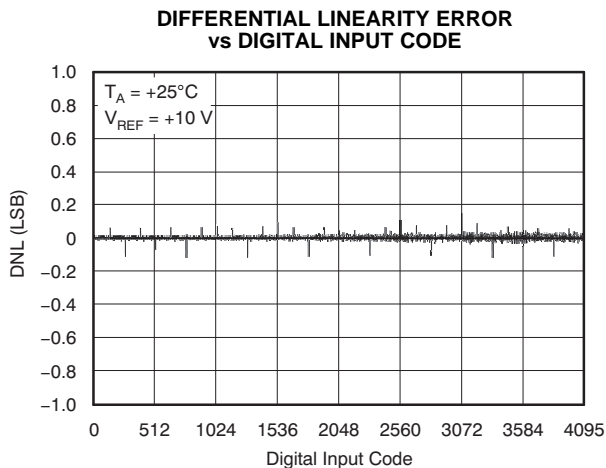

Figure 2.

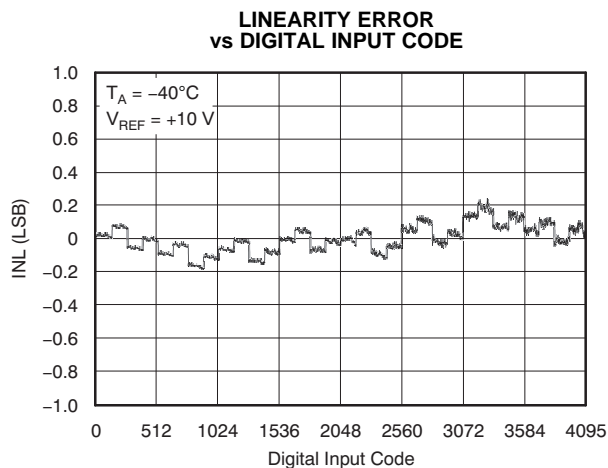

Figure 3.

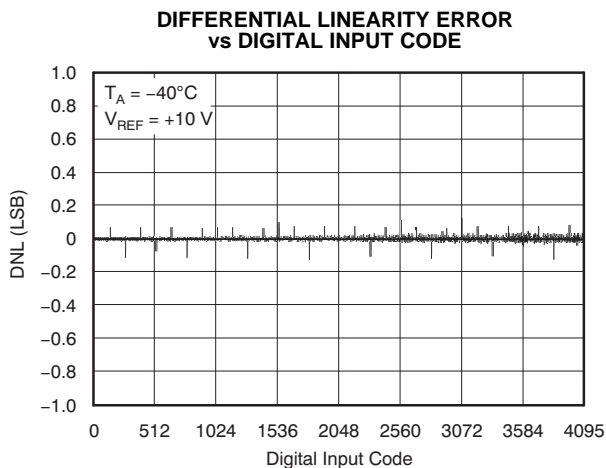

Figure 4.

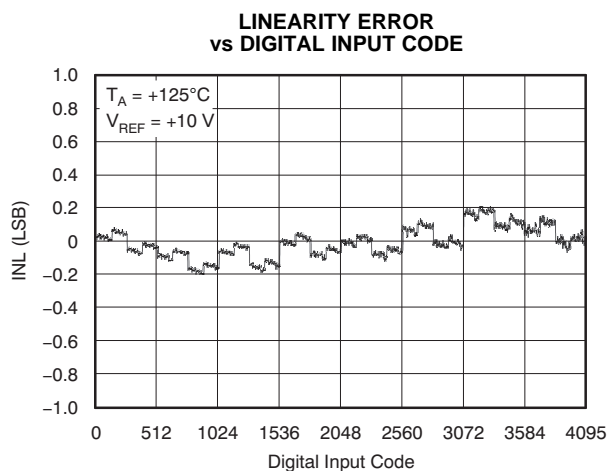

Figure 5.

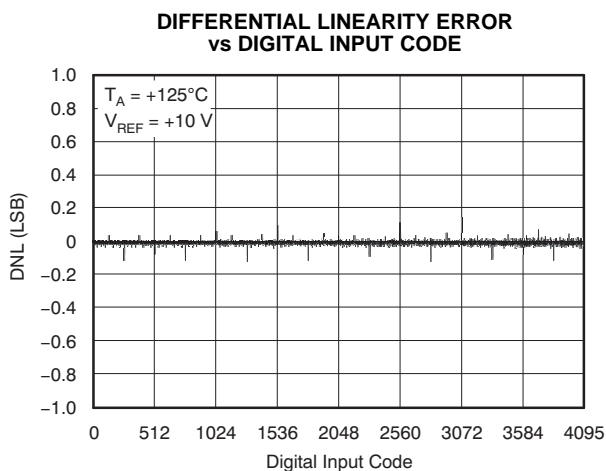

Figure 6.

TYPICAL CHARACTERISTICS:  $V_{DD} = +5V$  (continued)

At  $T_A = +25^\circ C$ , unless otherwise noted.

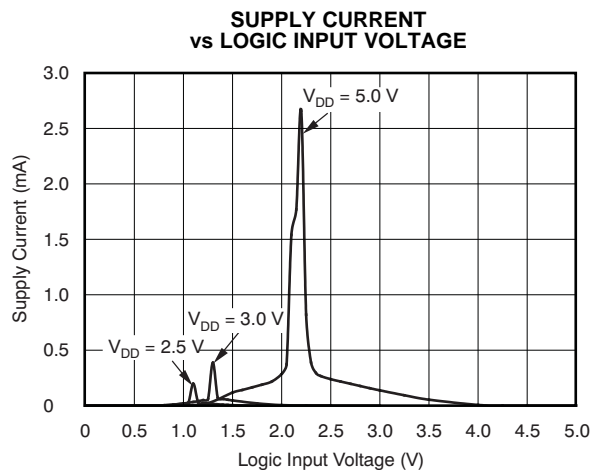

Figure 7.

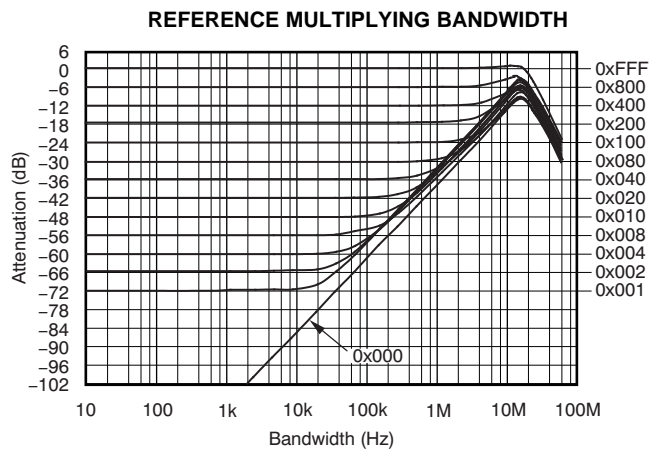

Figure 8.

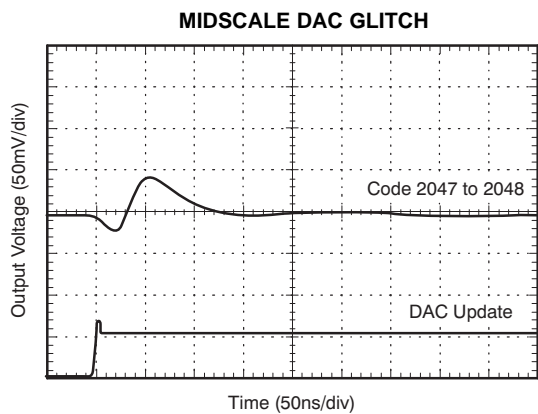

Figure 9.

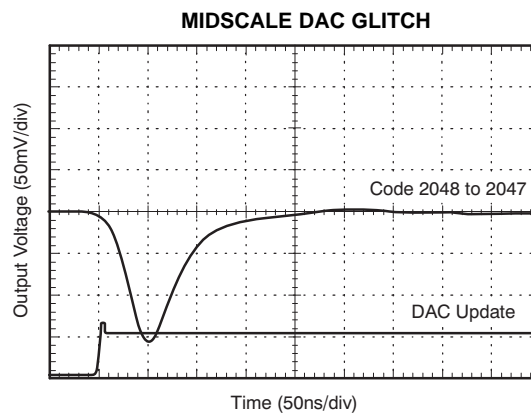

Figure 10.

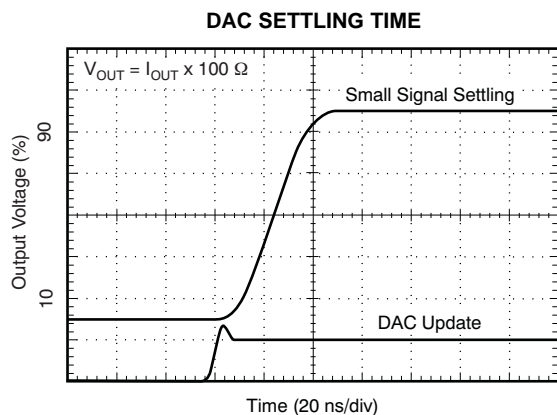

Figure 11.

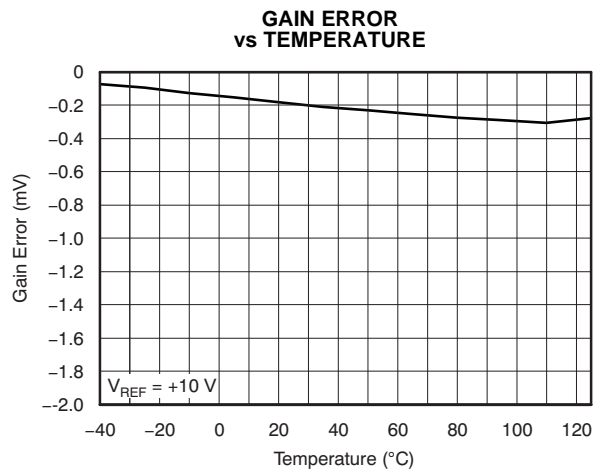
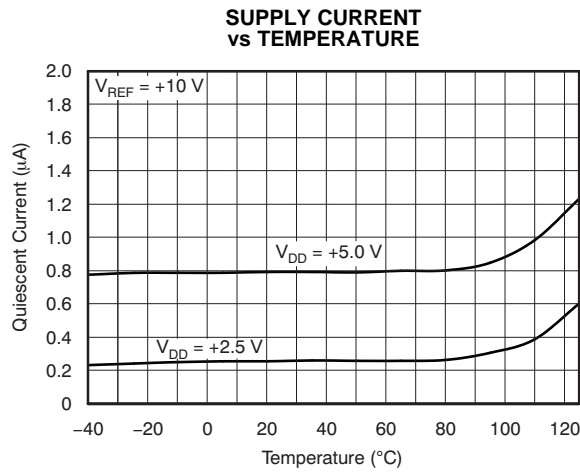

Figure 12.

**TYPICAL CHARACTERISTICS:  $V_{DD} = +5V$  (continued)**

At  $T_A = +25^\circ C$ , unless otherwise noted.



**Figure 13.**

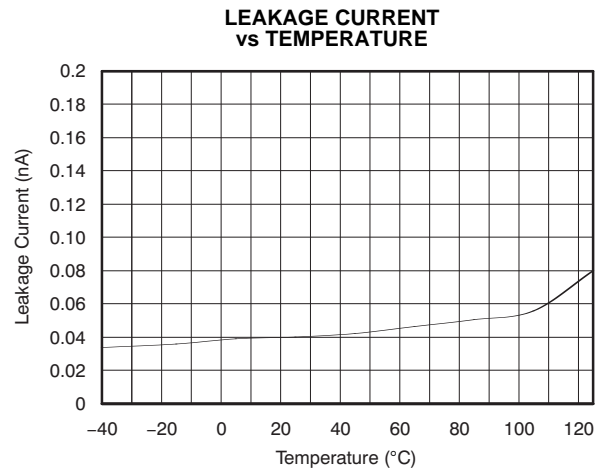

**Figure 14.**

**TYPICAL CHARACTERISTICS:  $V_{DD} = +2.5V$**

At  $T_A = +25^\circ C$ , unless otherwise noted.

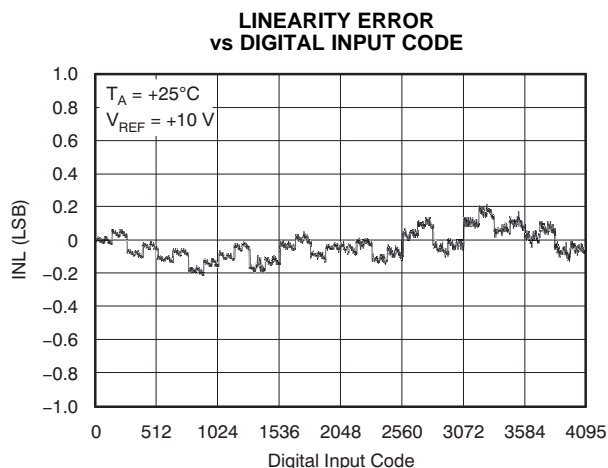

Figure 15.

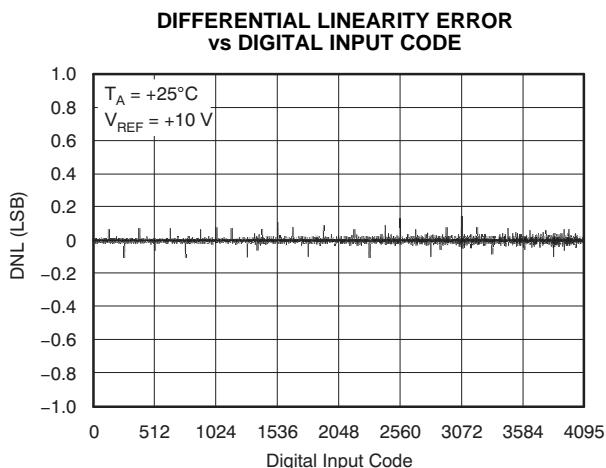

Figure 16.

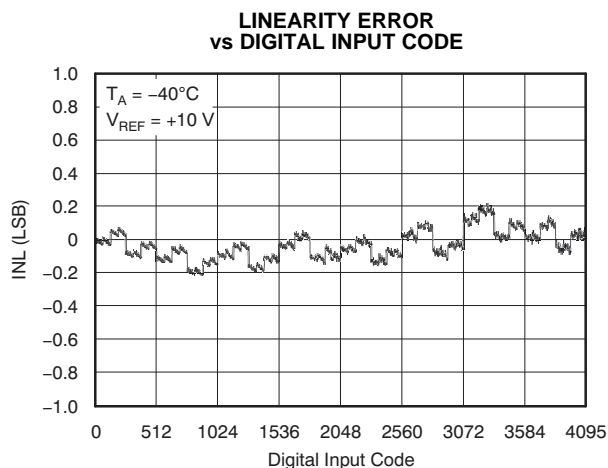

Figure 17.

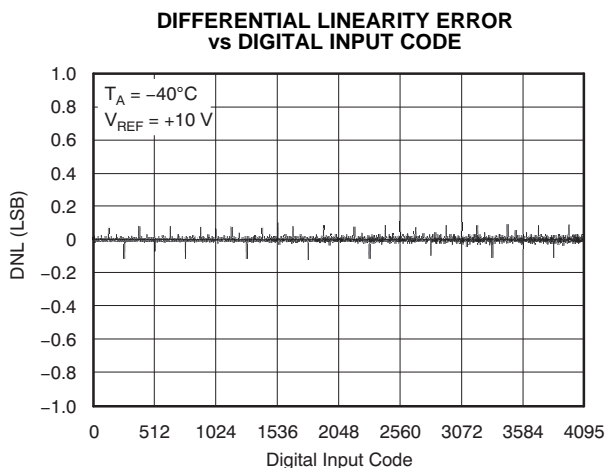

Figure 18.

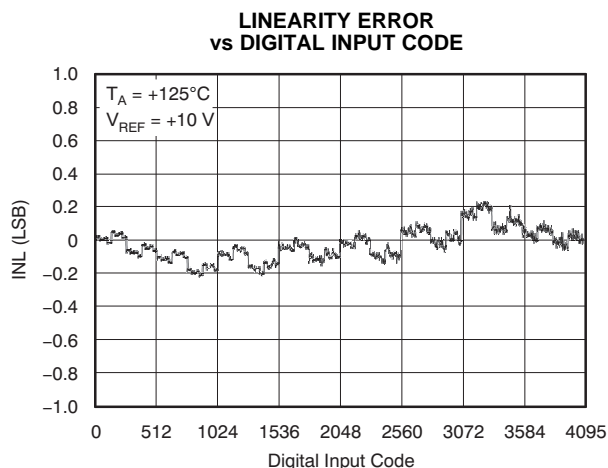

Figure 19.

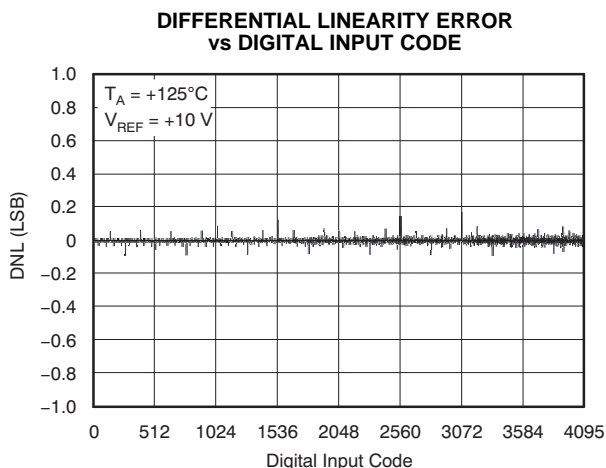
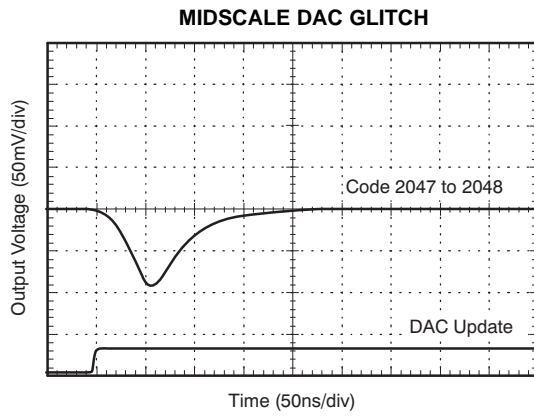

Figure 20.

**TYPICAL CHARACTERISTICS:  $V_{DD} = +2.5V$  (continued)**

At  $T_A = +25^\circ C$ , unless otherwise noted.



**Figure 21.**

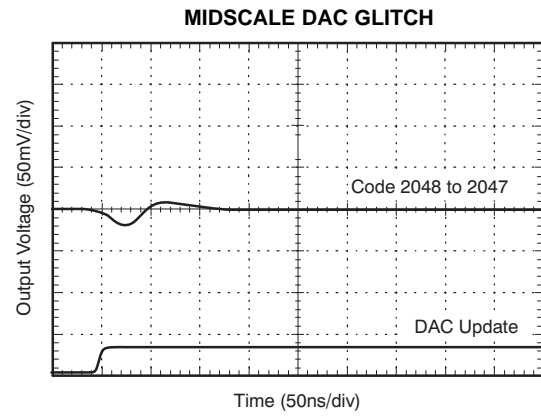

**Figure 22.**

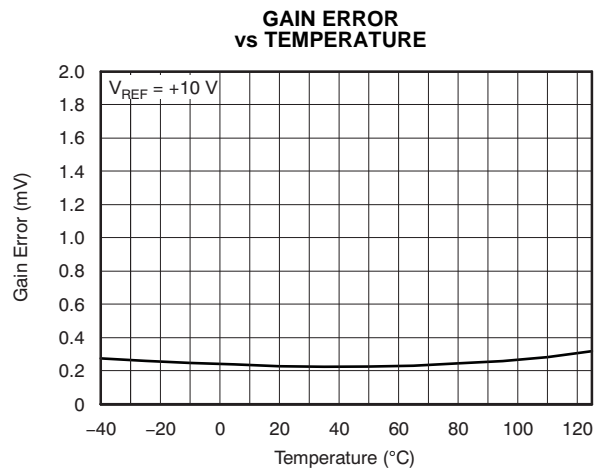

**Figure 23.**

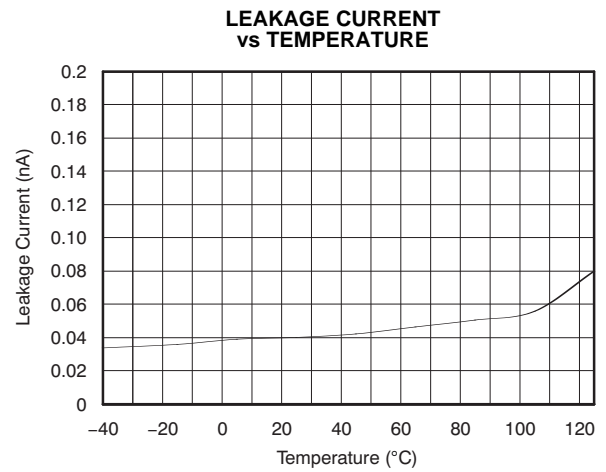

**Figure 24.**

## THEORY OF OPERATION

The DAC7821 is a single channel, current output, 12-bit digital-to-analog converter (DAC). The architecture, illustrated in [Figure 25](#), is an R-2R ladder configuration with the three MSBs segmented. Each 2R leg of the ladder is either switched to  $I_{OUT1}$  or the  $I_{OUT2}$  terminal. The  $I_{OUT1}$  terminal of the DAC is held at a virtual GND potential by the use of an external I/V converter op amp. The R-2R ladder is connected to an external reference input  $V_{REF}$  that determines the DAC full-scale current. The R-2R ladder presents a code-independent load impedance to the external reference of  $10k\Omega \pm 20\%$ . The external reference voltage can vary over a range of  $-15V$  to  $+15V$ , thus providing bipolar  $I_{OUT}$  current operation. By using an external I/V converter and the DAC7821  $R_{FB}$  resistor, output voltage ranges of  $-V_{REF}$  to  $V_{REF}$  can be generated.

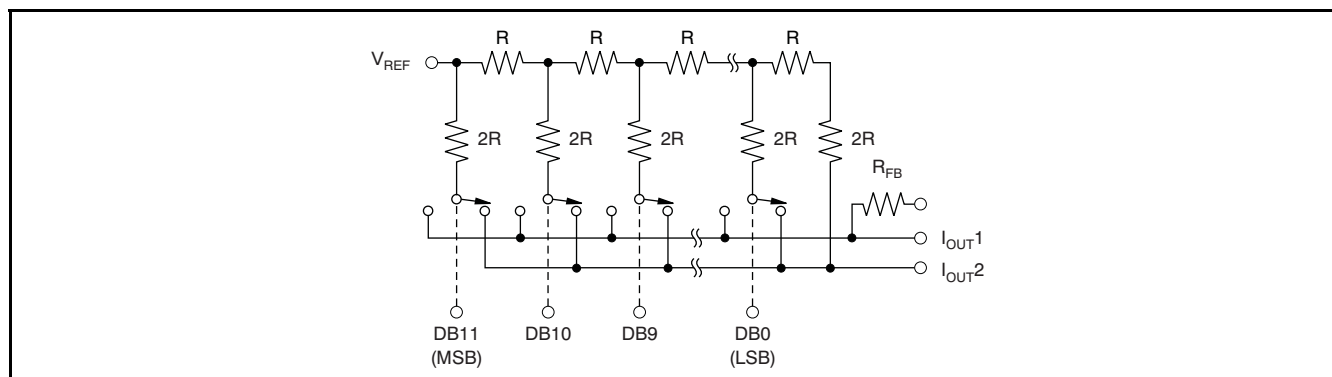

**Figure 25. Equivalent R-2R DAC Circuit**

When using an external I/V converter and the DAC7821  $R_{FB}$  resistor, the DAC output voltage is given by [Equation 1](#):

$$V_{OUT} = -V_{REF} \times \frac{CODE}{4096} \quad (1)$$

Each DAC code determines the 2R leg switch position to either GND or  $I_{OUT1}$ . Because the DAC output impedance as seen looking into the  $I_{OUT1}$  terminal changes versus code, the external I/V converter noise gain will also change. Because of this, the external I/V converter op amp must have a sufficiently low offset voltage such that the amplifier offset is not modulated by the DAC  $I_{OUT1}$  terminal impedance change. External op amps with large offset voltages can produce INL errors in the transfer function of the DAC7821 as a result of offset modulation versus DAC code.

For best linearity performance of the DAC7821, an op amp with a low input offset voltage ([OPA277](#)) is recommended (see [Figure 26](#)). This circuit allows  $V_{REF}$  swinging from  $-10V$  to  $+10V$ .

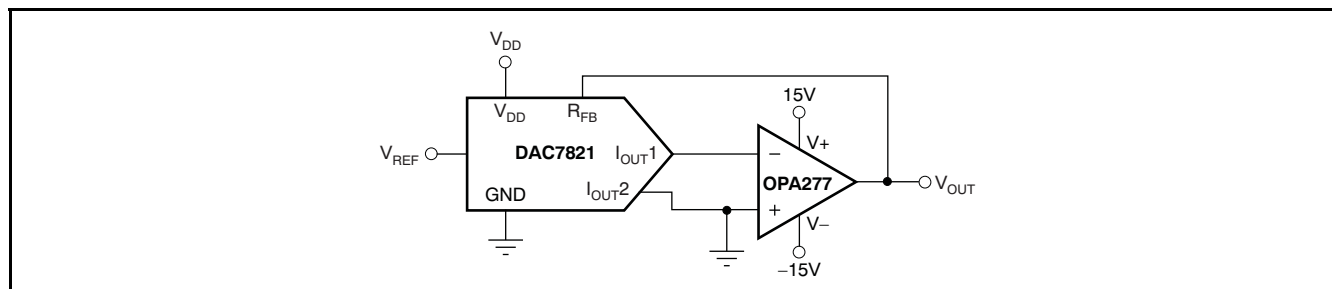

**Figure 26. Voltage Output Configuration**

APPLICATION INFORMATION

Stability Circuit

For a current-to-voltage design (see Figure 27), the DAC7821 current output ( $I_{OUT}$ ) and the connection with the inverting node of the op amp should be as short as possible and according to correct printed circuit board (PCB) layout design practices. For each code change, there is a step function. If the gain bandwidth product (GBP) of the op amp is limited and parasitic capacitance is excessive at the inverting node, then gain peaking is possible. Therefore, for circuit stability, compensation capacitor  $C_1$  (1pF to 5pF typ) can be added to the design, as shown in Figure 27.

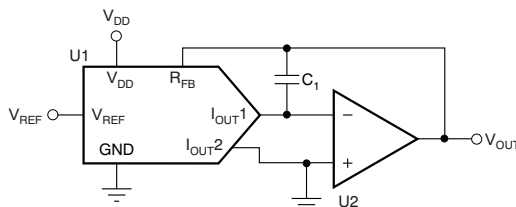

Figure 27. Gain Peaking Prevention Circuit with Compensation Capacitor

Amplifier Selection

There are many choices and many differences in selecting the proper operational amplifier for a multiplying DAC (MDAC). Making the analog signal out of the MDAC is one critical aspect. However, there are also other issues to take into account such as amplifier noise, input bias current, and offset voltage, as well as MDAC resolution and glitch energy. Table 1 and Table 2 suggest some suitable operational amplifiers for low power, fast settling, and high-speed applications. A greater selection of operational amplifiers can be found at [www.ti.com/amplifier](http://www.ti.com/amplifier).

Table 1. Suitable Precision Operational Amplifiers from Texas Instruments

PRODUCT	TOTAL SUPPLY VOLTAGE (V) (min)	TOTAL SUPPLY VOLTAGE (V) (max)	$I_Q$ PER CHANNEL (max) (mA)	GBW (typ) (MHz)	SLEW RATE (typ) (V/ $\mu$ s)	OFFSET DRIFT (typ) ( $\mu$ V/ $^{\circ}$ C)	$I_{IB}$ (max) (pA)	CMRR (min) (dB)	PACKAGE/ LEAD	DESCRIPTION
<b>Low Power</b>										
OPA703	4	12	0.2	1	0.6	4	10	70	SOT5-23, PDIP-8, SOIC-8	12V, CMOS, Rail-to-Rail I/O, Operational Amplifier
OPA735	2.7	12	0.75	1.6	1.5	0.01	200	115	SOT5-23, SOIC-8	0.05 $\mu$ V/ $^{\circ}$ C (max), Single-Supply CMOS Zero-Drift Series Operational Amplifier
OPA344	2.7	5.5	0.25	1	1	2.5	10	80	SOT5-23, PDIP-8, SOIC-8	Low Power, Single-Supply, Rail-To-Rail Operational Amplifiers MicroAmplifier Series
OPA348	2.1	5.5	0.065	1	0.5	2	10	70	SC5-70, SOT5-23, SOIC-8	1MHz, 45 $\mu$ A, Rail-to-Rail I/O, Single Op Amp
OPA277	4	36	0.825	1	0.8	0.1	1000	130	PDIP-8, SOIC-8, SON-8	High Precision Operational Amplifiers
<b>Fast Settling</b>										
OPA350	2.7	5.5	7.5	38	22	4	10	76	MSOP-8, PDIP-8, SOIC-8	High-Speed, Single-Supply, Rail-to-Rail Operational Amplifiers MicroAmplifier Series
OPA727	4	12	6.5	20	30	0.6	500	86	MSOP-8, SON-8	e-trim 20MHz, High Precision CMOS Operational Amplifier
OPA227	5	36	3.8	8	2.3	0.1	10000	120	PDIP-8, SOIC-8	High Precision, Low Noise Operational Amplifiers

**Table 2. Suitable High Speed Operational Amplifiers from Texas Instruments (Multiple Channel Options)**

PRODUCT	SUPPLY VOLTAGE (V)	GBW PRODUCT (MHz)	VOLTAGE NOISE nV/ $\sqrt{\text{Hz}}$	GBW (typ) (MHz)	SLEW RATE (V/ $\mu\text{s}$ )	V <sub>os</sub> (typ) ( $\mu\text{V}$ )	V <sub>os</sub> (max) ( $\mu\text{V}$ )	CMRR (min) (dB)	PACKAGE/ LEAD	DESCRIPTION
<b>Single Channel</b>										
THS4281	$\pm 2.7$ to $\pm 15$	38	12.5	35	500	3500	500	1000	SOT5-23, MSOP-8, SOIC-8	Very Low-Power High Speed Rail-To-Rail Input/Output Voltage Feedback Operational Amplifier
THS4031	$\pm 4.5$ to $\pm 16.5$	200	1.6	100	500	3000	3000	8000	CDIP-8, MSOP-8, SOIC-8	100-MHz Low Noise Voltage-Feedback Amplifier
THS4631	$\pm 4.5$ to $\pm 16.5$	210	7	900	260	2000	50pA	2	SOIC-8, MSOP-8	High Speed FET-Input Operational Amplifier
OPA656	$\pm 4$ to $\pm 6$	230	7	290	250	2600	2pA	5pA	SOIC-8, SOT5-23	Wideband, Unity Gain Stable FET-Input Operational Amplifier
OPA820	$\pm 2.5$ to $\pm 6$	280	2.5	240	200	1200	900	23,000	SOIC-8, SOT5-23	Unity Gain Stable, Low Noise, Voltage Feedback Operational Amplifier
<b>Dual Channel</b>										
THS4032	$\pm 4.5$ to $\pm 16.5$	200	1.6	100	500	3000	3000	8000	SOIC-8, MSOP-8	100-MHz Low Noise Voltage-Feedback Amplifier, Dual
OPA2822	$\pm 2$ to $\pm 6.3$	220	2	170	200	1200	9600	12000	SOIC-8, MSOP-8	SpeedPlus Dual Wideband, Low-Noise Operational Amplifier

### Positive Voltage Output Circuit

As Figure 28 illustrates, in order to generate a positive voltage output, a negative reference is input to the DAC7821. This design is suggested instead of using an inverting amp to invert the output because of possible resistor tolerance errors. For a negative reference,  $V_{OUT}$  and GND of the reference are level-shifted to a virtual ground and a  $-2.5V$  input to the DAC7821 with an op amp.

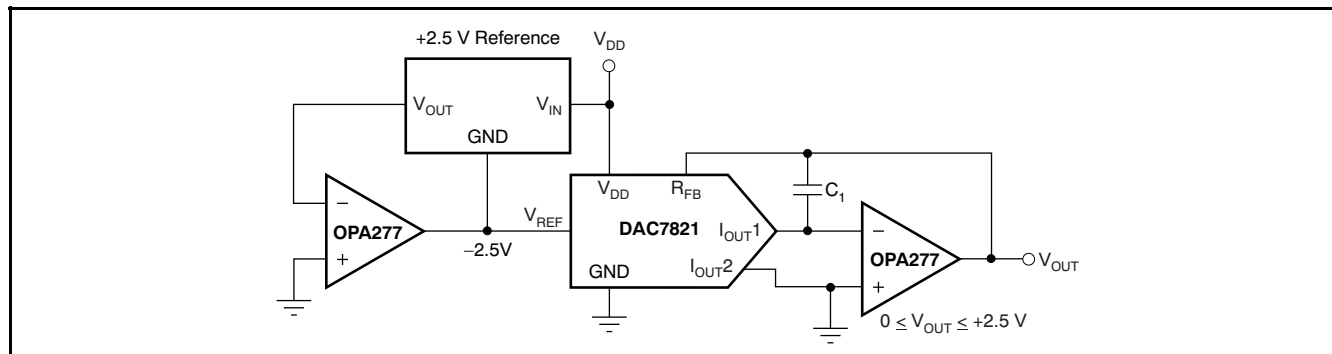

Figure 28. Positive Voltage Output Circuit

### Bipolar Output Section

The DAC7821, as a 2-quadrant multiplying DAC, can be used to generate a unipolar output. The polarity of the full-scale output  $I_{OUT}$  is the inverse of the input reference voltage at  $V_{REF}$ .

Some applications require full 4-quadrant multiplying capabilities or bipolar output swing. As shown in Figure 29, external op amp U4 is added as a summing amp and has a gain of 2X that widens the output span to 5V. A 4-quadrant multiplying circuit is implemented by using a 2.5V offset of the reference voltage to bias U4. According to the circuit transfer equation given in Equation 2, input data (D) from code 0 to full-scale produces output voltages of  $V_{OUT} = -2.5V$  to  $V_{OUT} = +2.5V$ .

$$V_{OUT} = \left( \frac{D}{0.5 \times 2^N} - 1 \right) \times V_{REF} \tag{2}$$

External resistance mismatching is the significant error in Figure 29.

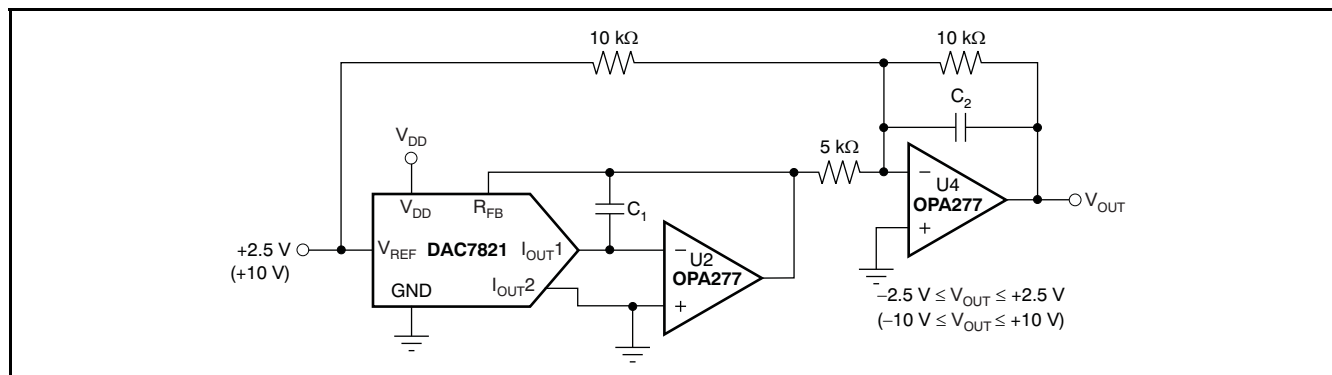

Figure 29. Bipolar Output Circuit

### Programmable Current Source Circuit

A DAC7821 can be integrated into the circuit in [Figure 30](#) to implement an improved Howland current pump for precise voltage-to-current conversions. Bidirectional current flow and high voltage compliance are two features of the circuit. With a matched resistor network, the load current of the circuit is shown by [Equation 3](#):

$$I_L = \frac{(R_2 + R_3)/R_1}{R_3} \times V_{REF} \times D \quad (3)$$

The value of  $R_3$  in the previous equation can be reduced to increase the output current drive of  $U_3$ .  $U_3$  can drive  $\pm 20\text{mA}$  in both directions with voltage compliance limited up to  $15\text{V}$  by the  $U_3$  voltage supply. Elimination of the circuit compensation capacitor  $C_1$  in the circuit is not suggested as a result of the change in the output impedance  $Z_O$ , according to [Equation 4](#):

$$Z_O = \frac{R_1' R_3 (R_1 + R_2)}{R_1 (R_2' + R_3') - R_1' (R_2 + R_3)} \quad (4)$$

As shown in [Equation 4](#), with matched resistors,  $Z_O$  is infinite and the circuit is optimum for use as a current source. However, if unmatched resistors are used,  $Z_O$  is positive or negative with negative output impedance being a potential cause of oscillation. Therefore, by incorporating  $C_1$  into the circuit, possible oscillation problems are eliminated. The value of  $C_1$  can be determined for critical applications; for most applications, however, a value of several pF is suggested.

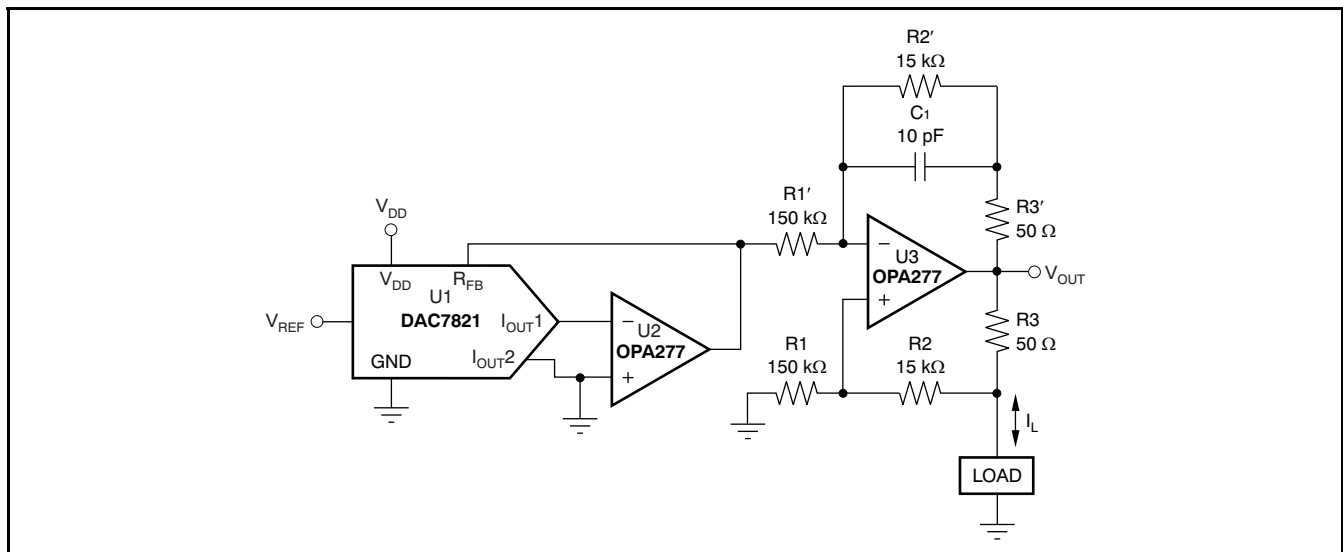

Figure 30. Programmable Bidirectional Current Source Circuit

## Parallel Interface

Data are loaded to the DAC7821 as a 12-bit parallel word. The bidirectional bus is controlled with  $\overline{CS}$  and  $R/\overline{W}$ , allowing data to be written to or read from the DAC register. To write to the device,  $\overline{CS}$  and  $R/\overline{W}$  are brought low, and data available on the data lines fill the input register. The rising edge of  $\overline{CS}$  latches the data and transfers the latched data-word to the DAC register. The DAC latches are not transparent; therefore, a write sequence must consist of a falling and rising edge on  $\overline{CS}$  in order to ensure that data are loaded to the DAC register and its analog equivalent is reflected on the DAC output.

To read data stored in the device,  $R/\overline{W}$  is held high and  $\overline{CS}$  is brought low. Data are loaded from the DAC register back to the input register and out onto the data line, where it can be read back to the controller.

## Cross-Reference

The DAC7821 has an industry-standard pinout. [Table 3](#) provides the cross-reference information.

**Table 3. Cross-Reference**

PRODUCT	INL (LSB)	DNL (LSB)	SPECIFIED TEMPERATURE RANGE	PACKAGE DESCRIPTION	PACKAGE OPTION	CROSS-REFERENCE PART
DAC7821	±1	±1	–40°C to +125°C	20-Lead TSSOP	TSSOP-20	AD5445

**PACKAGING INFORMATION**

Orderable Device	Status <sup>(1)</sup>	Package Type	Package Drawing	Pins	Package Qty	Eco Plan <sup>(2)</sup>	Lead/Ball Finish	MSL Peak Temp <sup>(3)</sup>
DAC7821IPW	ACTIVE	TSSOP	PW	20	78	Green (RoHS & no Sb/Br)	CU NIPDAU	Level-2-260C-1 YEAR
DAC7821IPWG4	ACTIVE	TSSOP	PW	20	78	Green (RoHS & no Sb/Br)	CU NIPDAU	Level-2-260C-1 YEAR
DAC7821IPWR	ACTIVE	TSSOP	PW	20	2000	TBD	Call TI	Call TI
DAC7821IPWRG4	ACTIVE	TSSOP	PW	20	2000	TBD	Call TI	Call TI

<sup>(1)</sup> The marketing status values are defined as follows:

**ACTIVE:** Product device recommended for new designs.

**LIFEBUY:** TI has announced that the device will be discontinued, and a lifetime-buy period is in effect.

**NRND:** Not recommended for new designs. Device is in production to support existing customers, but TI does not recommend using this part in a new design.

**PREVIEW:** Device has been announced but is not in production. Samples may or may not be available.

**OBSOLETE:** TI has discontinued the production of the device.

<sup>(2)</sup> Eco Plan - The planned eco-friendly classification: Pb-Free (RoHS), Pb-Free (RoHS Exempt), or Green (RoHS & no Sb/Br) - please check <http://www.ti.com/productcontent> for the latest availability information and additional product content details.

**TBD:** The Pb-Free/Green conversion plan has not been defined.

**Pb-Free (RoHS):** TI's terms "Lead-Free" or "Pb-Free" mean semiconductor products that are compatible with the current RoHS requirements for all 6 substances, including the requirement that lead not exceed 0.1% by weight in homogeneous materials. Where designed to be soldered at high temperatures, TI Pb-Free products are suitable for use in specified lead-free processes.

**Pb-Free (RoHS Exempt):** This component has a RoHS exemption for either 1) lead-based flip-chip solder bumps used between the die and package, or 2) lead-based die adhesive used between the die and leadframe. The component is otherwise considered Pb-Free (RoHS compatible) as defined above.

**Green (RoHS & no Sb/Br):** TI defines "Green" to mean Pb-Free (RoHS compatible), and free of Bromine (Br) and Antimony (Sb) based flame retardants (Br or Sb do not exceed 0.1% by weight in homogeneous material)

<sup>(3)</sup> MSL, Peak Temp. -- The Moisture Sensitivity Level rating according to the JEDEC industry standard classifications, and peak solder temperature.

**Important Information and Disclaimer:**The information provided on this page represents TI's knowledge and belief as of the date that it is provided. TI bases its knowledge and belief on information provided by third parties, and makes no representation or warranty as to the accuracy of such information. Efforts are underway to better integrate information from third parties. TI has taken and continues to take reasonable steps to provide representative and accurate information but may not have conducted destructive testing or chemical analysis on incoming materials and chemicals. TI and TI suppliers consider certain information to be proprietary, and thus CAS numbers and other limited information may not be available for release.

In no event shall TI's liability arising out of such information exceed the total purchase price of the TI part(s) at issue in this document sold by TI to Customer on an annual basis.

PW (R-PDSO-G\*\*)

PLASTIC SMALL-OUTLINE PACKAGE

14 PINS SHOWN



4040064/F 01/97

- NOTES: A. All linear dimensions are in millimeters.  
 B. This drawing is subject to change without notice.  
 C. Body dimensions do not include mold flash or protrusion not to exceed 0,15.  
 D. Falls within JEDEC MO-153

## IMPORTANT NOTICE

Texas Instruments Incorporated and its subsidiaries (TI) reserve the right to make corrections, modifications, enhancements, improvements, and other changes to its products and services at any time and to discontinue any product or service without notice. Customers should obtain the latest relevant information before placing orders and should verify that such information is current and complete. All products are sold subject to TI's terms and conditions of sale supplied at the time of order acknowledgment.

TI warrants performance of its hardware products to the specifications applicable at the time of sale in accordance with TI's standard warranty. Testing and other quality control techniques are used to the extent TI deems necessary to support this warranty. Except where mandated by government requirements, testing of all parameters of each product is not necessarily performed.

TI assumes no liability for applications assistance or customer product design. Customers are responsible for their products and applications using TI components. To minimize the risks associated with customer products and applications, customers should provide adequate design and operating safeguards.

TI does not warrant or represent that any license, either express or implied, is granted under any TI patent right, copyright, mask work right, or other TI intellectual property right relating to any combination, machine, or process in which TI products or services are used. Information published by TI regarding third-party products or services does not constitute a license from TI to use such products or services or a warranty or endorsement thereof. Use of such information may require a license from a third party under the patents or other intellectual property of the third party, or a license from TI under the patents or other intellectual property of TI.

Reproduction of TI information in TI data books or data sheets is permissible only if reproduction is without alteration and is accompanied by all associated warranties, conditions, limitations, and notices. Reproduction of this information with alteration is an unfair and deceptive business practice. TI is not responsible or liable for such altered documentation. Information of third parties may be subject to additional restrictions.

Resale of TI products or services with statements different from or beyond the parameters stated by TI for that product or service voids all express and any implied warranties for the associated TI product or service and is an unfair and deceptive business practice. TI is not responsible or liable for any such statements.

TI products are not authorized for use in safety-critical applications (such as life support) where a failure of the TI product would reasonably be expected to cause severe personal injury or death, unless officers of the parties have executed an agreement specifically governing such use. Buyers represent that they have all necessary expertise in the safety and regulatory ramifications of their applications, and acknowledge and agree that they are solely responsible for all legal, regulatory and safety-related requirements concerning their products and any use of TI products in such safety-critical applications, notwithstanding any applications-related information or support that may be provided by TI. Further, Buyers must fully indemnify TI and its representatives against any damages arising out of the use of TI products in such safety-critical applications.

TI products are neither designed nor intended for use in military/aerospace applications or environments unless the TI products are specifically designated by TI as military-grade or "enhanced plastic." Only products designated by TI as military-grade meet military specifications. Buyers acknowledge and agree that any such use of TI products which TI has not designated as military-grade is solely at the Buyer's risk, and that they are solely responsible for compliance with all legal and regulatory requirements in connection with such use.

TI products are neither designed nor intended for use in automotive applications or environments unless the specific TI products are designated by TI as compliant with ISO/TS 16949 requirements. Buyers acknowledge and agree that, if they use any non-designated products in automotive applications, TI will not be responsible for any failure to meet such requirements.

Following are URLs where you can obtain information on other Texas Instruments products and application solutions:

<b>Products</b>		<b>Applications</b>	
Amplifiers	<a href="http://amplifier.ti.com">amplifier.ti.com</a>	Audio	<a href="http://www.ti.com/audio">www.ti.com/audio</a>
Data Converters	<a href="http://dataconverter.ti.com">dataconverter.ti.com</a>	Automotive	<a href="http://www.ti.com/automotive">www.ti.com/automotive</a>
DSP	<a href="http://dsp.ti.com">dsp.ti.com</a>	Broadband	<a href="http://www.ti.com/broadband">www.ti.com/broadband</a>
Interface	<a href="http://interface.ti.com">interface.ti.com</a>	Digital Control	<a href="http://www.ti.com/digitalcontrol">www.ti.com/digitalcontrol</a>
Logic	<a href="http://logic.ti.com">logic.ti.com</a>	Military	<a href="http://www.ti.com/military">www.ti.com/military</a>
Power Mgmt	<a href="http://power.ti.com">power.ti.com</a>	Optical Networking	<a href="http://www.ti.com/opticalnetwork">www.ti.com/opticalnetwork</a>
Microcontrollers	<a href="http://microcontroller.ti.com">microcontroller.ti.com</a>	Security	<a href="http://www.ti.com/security">www.ti.com/security</a>
RFID	<a href="http://www.ti-rfid.com">www.ti-rfid.com</a>	Telephony	<a href="http://www.ti.com/telephony">www.ti.com/telephony</a>
Low Power Wireless	<a href="http://www.ti.com/lpw">www.ti.com/lpw</a>	Video & Imaging	<a href="http://www.ti.com/video">www.ti.com/video</a>
		Wireless	<a href="http://www.ti.com/wireless">www.ti.com/wireless</a>

Mailing Address: Texas Instruments, Post Office Box 655303, Dallas, Texas 75265  
Copyright © 2007, Texas Instruments Incorporated