

Dual-Channel, 16-Bit, 1.6/2.5 GSPS, Digital-to-Analog Converter with 12.5 Gbps JESD204B Interface

Check for Samples: [DAC37J82](#), [DAC38J82](#)

FEATURES

- **Resolution: 16-Bit**
- **Maximum Sample Rate:**
 - **DAC37J82: 1.6 GSPS**
 - **DAC38J82: 2.5 GSPS**
- **Maximum Input Data Rate: 1.23GSPS**
- **JESD204B Interface**
 - **8 JESD204B Serial Input Lanes**
 - **12.5 Gbps Maximum Bit Rate per Lane**
 - **Subclass 1 Multi-DAC synchronization**
- **On-Chip Very Low Jitter PLL**
- **Selectable 1x -16x Interpolation**
- **Independent Complex Mixers with 48-bit NCO/
or $\pm n \times F_s/8$**
- **Wideband Digital Quadrature Modulator
Correction**
- **Sinx/x Correction Filters**
- **Fractional Sample Group Delay Correction**
- **Multi-Band Mode: Digital Summation of
Independent Complex Signals**
- **3/4-Wire Serial Control Bus (SPI): 1.5V – 1.8V**
- **Integrated Temperature Sensor**
- **JTAG Boundary Scan**
- **Pin-compatible with Quad-channel
DAC37J84/DAC38J84**
- **Power Dissipation: 1.1W at 2.5GSPS**
- **Package: 10x10mm, 144-Ball Flip-Chip BGA**

APPLICATIONS

- **Cellular Base Stations**
- **Diversity Transmit**
- **Wideband Communications**
- **Direct Digital Synthesis (DDS) Instruments**
- **Millimeter/Microwave Backhaul**
- **Automated Test Equipment**
- **Cable Infrastructure**

DESCRIPTION

The pin-compatible DAC37J82/DAC38J82 family is a very low power, 16-bit, dual-channel, 1.6/2.5 GSPS digital to analog converter (DAC) with JESD204B interface up to 12.5 Gbps. The maximum input data rate is 1.23 GSPS. The DAC37J82/DAC38J82 family is also pin-compatible with the 16-bit, quad-channel, 1.6/2.5 GSPS DAC37J84/DAC38J84 family.

Digital data is input to the device through 1, 2, 4 or 8 configurable serial JESD204B lanes running up to 12.5 Gbps with on-chip termination and programmable equalization. The interface allows JESD204B Subclass 1 SYSREF based deterministic latency and full synchronization of multiple devices.

The device includes features that simplify the design of complex transmit architectures. Fully bypassable 2x to 16x digital interpolation filters with over 90 dB of stop-band attenuation simplify the data interface and reconstruction filters. An on-chip 48-bit Numerically Controlled Oscillator (NCO) and independent complex mixers allow flexible and accurate carrier placement. A high-performance low jitter PLL simplifies clocking of the device without significant impact on the dynamic range. The digital Quadrature Modulator Correction (QMC) and Group Delay Correction (QDC) enable complete IQ compensation for gain, offset, phase, and group delay between channels in direct up-conversion applications. A programmable Power Amplifier (PA) protection mechanism is available to provide PA protection in cases when the abnormal power behavior of the input data is detected.

The DAC37J82/DAC38J82 family is packaged in a 10x10mm 144-pin flip-chip BGA. The DAC37J82/DAC38J82 family is specified over the full industrial temperature range (-40°C to 85°C).



Please be aware that an important notice concerning availability, standard warranty, and use in critical applications of Texas Instruments semiconductor products and disclaimers thereto appears at the end of this data sheet.

BLOCK DIAGRAM

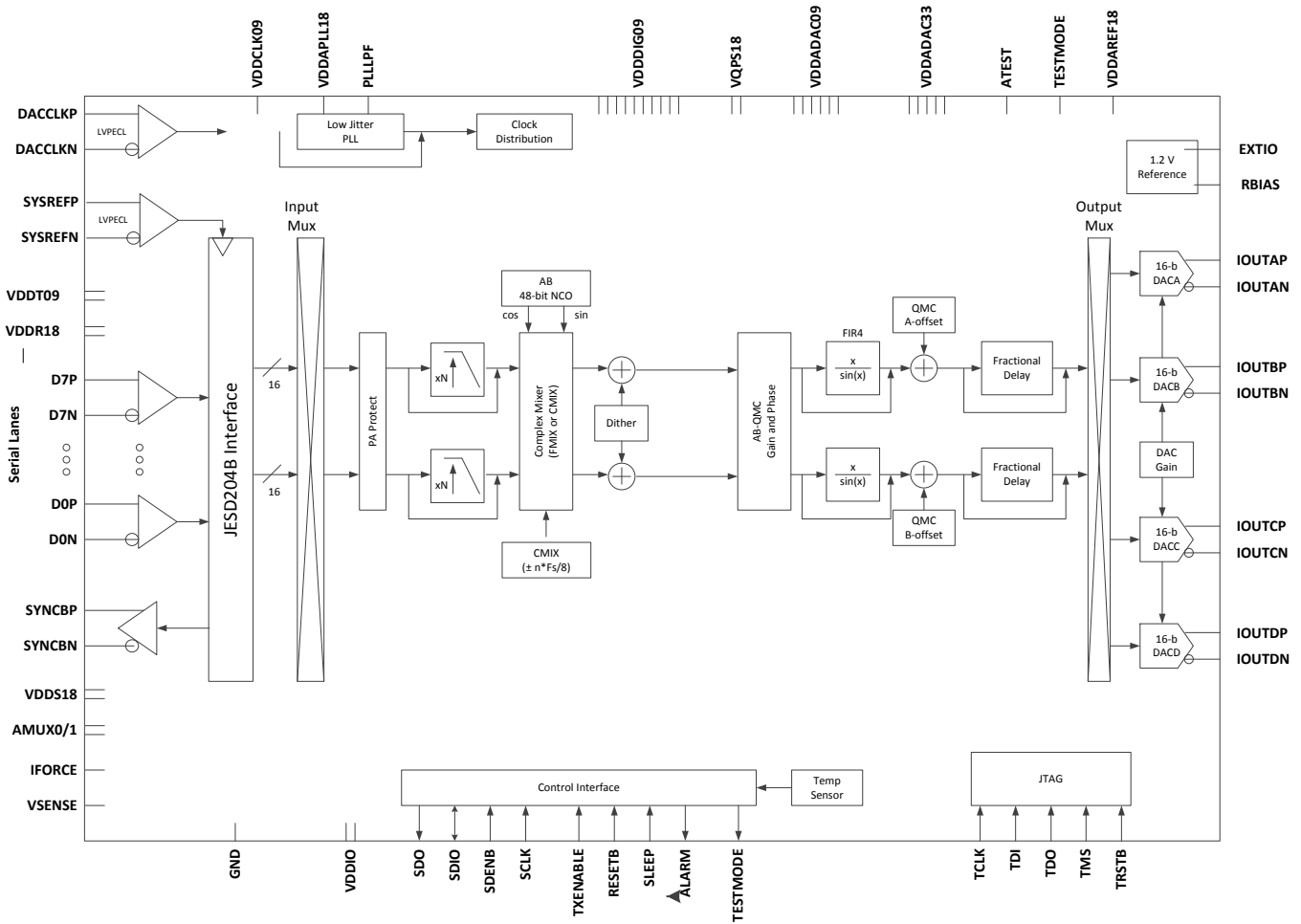

PRODUCT PREVIEW

CONTENTS

FEATURES 1

APPLICATIONS..... 1

DESCRIPTION 1

ABSOLUTE MAXIMUM RATINGS 6

THERMAL INFORMATION 6

RECOMMENDED OPERATING CONDITIONS 6

ELECTRICAL CHARACTERISTICS - DC SPECIFICATIONS (to be Verified) 7

ELECTRICAL CHARACTERISTICS – DC SPECIFICATIONS (to be verified)..... 8

ELECTRICAL CHARACTERISTICS – DC SPECIFICATIONS (to be verified)..... 9

ELECTRICAL CHARACTERISTICS – DIGITAL SPECIFICATIONS (to be verified) 10

ELECTRICAL CHARACTERISTICS – AC SPECIFICATIONS (to be verified)..... 11

TYPICAL PERFORMANCE PLOTS 13

Table 1. Ordering Information

T _A	ORDER CODE	PACKAGE DRAWING/TYPE ⁽¹⁾	TRANSPORT MEDIA	QUANTITY
–40°C to 85°C	DAC37J82IAAV	AAV/144-ball flip chip BGA	Tape and Reel	160
	DAC37J82IAAVR			1000
–40°C to 85°C	DAC38J82IAAV	AAV/144-ball flip chip BGA	Tape and Reel	160
	DAC38J82IAAVR			1000

(1) MSL Peak Temperature: Level-3-260C-168 HR

PIN ASSIGNMENT (Top view)

	A	B	C	D	E	F	G	H	J	K	L	M	
12	GND	IOUTAP	IOUTAN	IOUTBN	IOUTBP	GND	GND	IOUTCP	IOUTCN	IOUTDN	IOUTDP	GND	12
11	GND	GND	GND	GND	GND	GND	GND	GND	GND	GND	GND	GND	11
10	DACCLKP	VDDAPLL 1.8V	VDDAREF 1.8V	VDDADAC 3.3V	VDDADAC 3.3V	EXTIO	RBIAS	VDDADAC 3.3V	VDDADAC 3.3V	VDDAREF 1.8V	SDIO	SDO	10
9	DACCLKN	VDDAPLL 1.8V	LPF	VDDDAC 0.9V	VDDDAC 0.9V	VDDDAC 0.9V	VDDDAC 0.9V	VDDDAC 0.9V	VDDDAC 0.9V	ATEST	SCLK	SDENB	9
8	VDDCLK 0.9V	VDDCLK 0.9V	GND	GND	GND	GND	GND	GND	GND	RESETB	ALARM	SLEEP	8
7	SYSREFP	SYNCPB	VDDS 1.8V	VDDS 1.8V	GND	GND	GND	GND	VDDDIG 0.9V	VDDIO 1.8V	SYNC_N_CD	NC	7
6	SYSREFN	SYNCBN	VDDS 1.8V	VDDS 1.8V	GND	GND	GND	GND	VDDDIG 0.9V	VDDIO 1.8V	SYNC_N_AB	NC	6
5	GND	GND	IFORCE	VDDDIG 0.9V	GND	GND	GND	GND	VDDDIG 0.9V	TXENABLE	TDI	TDO	5
4	GND	GND	VSENSE	VDDDIG 0.9V	VDDDIG 0.9V	VDDDIG 0.9V	VDDDIG 0.9V	VDDDIG 0.9V	VDDDIG 0.9V	TCLK	TMS	GND	4
3	RXP7	GND	GND	VDDDIG 0.9V	AMUX1	VDDT 0.9V	VDDT 0.9V	AMUX0	TRSTB	TESTMODE	GND	RXP3	3
2	RXN7	GND	GND	GND	GND	VDDR 1.8V	VDDR 1.8V	GND	GND	GND	GND	RXN3	2
1	RXN6	RXP6	RXP5	RXN5	RXN4	RXP4	RXP0	RXN0	RXN1	RXP1	RXP2	RXN2	1
	A	B	C	D	E	F	G	H	J	K	L	M	

PRODUCT PREVIEW

Pin Functions

BALL NAME	BALL NO.	I/O	DESCRIPTION (SUBJECT TO CHANGE)
ALARM	L8	O	CMOS output for ALARM condition. The ALARM output functionality is defined through the <i>config7 register</i> . Default polarity is active low, but can be changed to active high via <i>config0 alarm_out_pol</i> control bit.
AMUX0	H3	I/O	Analog test pin for SerDes, Lane 0 to Lane 3
AMUX1	E3	I/O	Analog test pin for SerDes, Lane 4 to Lane 7
ATEST	K9	I/O	Analog test pin for DAC, references and PLL
DACCLKP	A10	I	Positive external LVPECL clock input for DAC core with a self-bias.
DACCLKN	A9	I	Complementary external LVPECL clock input for DAC core. (see the DACCLKP description)
EXTIO	F10	I/O	Used as external reference input when internal reference is disabled through <i>config27 extref_ena = '1'</i> . Used as internal reference output when <i>config27 extref_ena = '0'</i> (default). Requires a 0.1 μ F decoupling capacitor to AGND when used as reference output.
GND	A12, F12, G12, M12, A11, B11, C11, D11, E11, F11, G11, H11, J11, K11, L11, M11, C8, D8, E8, F8, G8, H8, J8, E7, F7, G7, H7, E6, F6, G6, H6, A5, B5, E5, F5, G5, H5, A4, B4, M4, B3, C3, L3, B2, C2, D2, E2, H2, J2, K2, L2	I	These pins are ground for all supplies.
IFORCE	C5	I/O	Analog test pin for on chip parameters
IOUTAP	B12	O	A-Channel DAC current output.
IOUTAN	C12	O	A-Channel DAC complementary current output.
IOUTBP	E12	O	B-Channel DAC current output.
IOUTBN	D12	O	B-Channel DAC complementary current output.
IOUTCP	H12	O	C-Channel DAC current output.
IOUTCN	J12	O	C-Channel DAC complementary current output.
IOUTDP	L12	O	D-Channel DAC current output.
IOUTDN	K12	O	D-Channel DAC complementary current output.
LPF	C9	I/O	PLL loop filter connection. If not using the clock multiplying PLL, the LPF pin can be left unconnected.
RBIAS	G10	O	Full-scale output current bias. Change the full-scale output current through <i>coarse_dac(3:0)</i> in <i>register tbd</i>
RESETB	K8	I	Active low input for chip RESET, which resets all the programming registers to their default state. Internal pull-up.
RX0P	G1	I	CML SerDes interface lane 0 input, positive
RX0N	H1	I	CML SerDes interface lane 0 input, negative
RX1P	K1	I	CML SerDes interface lane 1 input, positive
RX1N	J1	I	CML SerDes interface lane 1 input, negative
RX2P	L1	I	CML SerDes interface lane 2 input, positive
RX2N	M1	I	CML SerDes interface lane 2 input, negative
RX3P	M3	I	CML SerDes interface lane 3 input, positive
RX3N	M2	I	CML SerDes interface lane 3 input, negative
RX4P	F1	I	CML SerDes interface lane 4 input, positive
RX4N	E1	I	CML SerDes interface lane 4 input, negative
RX5P	C1	I	CML SerDes interface lane 5 input, positive
RX5N	D1	I	CML SerDes interface lane 5 input, negative
RX6P	B1	I	CML SerDes interface lane 6 input, positive
RX6N	A1	I	CML SerDes interface lane 6 input, negative

PRODUCT PREVIEW

Pin Functions (continued)

BALL NAME	BALL NO.	I/O	DESCRIPTION (SUBJECT TO CHANGE)
RX7P	A3	I	CML SerDes interface lane 7 input, positive
RX7N	A2	I	CML SerDes interface lane 7 input, negative
SYSREFP	A7	I	LVPECL SYSREF positive input. This positive/negative pair is captured with the rising edge of DACCLKP/N. It is used for multiple DAC synchronization.
SYSREFN	A6	I	LVPECL SYSREF negative input. (See the SYSREF description)
SCLK	L9	I	Serial interface clock. Internal pull-down.
SDENB	M9	I	Active low serial data enable, always an input to the DAC37J82/DAC38J82. Internal pull-up.
SDIO	L10	I/O	Serial interface data. Bi-directional in 3-pin mode (default) and 4-pin mode. Internal pull-down.
SDO	M10	O	Uni-directional serial interface data in 4-pin mode. The SDO pin is tri-stated in 3-pin interface mode (default).
SLEEP	M8	I	Active high asynchronous hardware power-down input. Internal pull-down.
SYNCBP	B7	O	Synchronization request to transmitter, LVDS positive output.
SYNCBN	B6	O	Synchronization request to transmitter, LVDS negative output.
SYNC_N_AB	L6	O	Synchronization request to transmitter, CMOS output. Defaults to link 0, but can be programmable for any link.
SYNC_N_CD	L7	O	Synchronization request to transmitter, CMOS output. Defaults to link 1, but can be programmable for any link.
TCLK	K4	I	JTAG test clock.
TDI	L5	I	JTAG test data in.
TDO	M5	O	JTAG test data out.
TMS	L4	I	JTAG test mode select.
TRSTB	J3	I	JTAG test reset. Must be pulled low if the JTAG port is not used.
TXENABLE	K5	I	Transmit enable active high input. Internal pull-down. To enable analog output data transmission, set <i>sif_txenable</i> in register <i>config3</i> to "1" or pull CMOS TXENABLE pin to high. To disable analog output, set <i>sif_txenable</i> to "0" and pull CMOS TXENABLE pin to low. The DAC output is forced to midscale.
TESTMODE	K3	O	This pin is used for factory testing. Internal pull-down. Leave unconnected for normal operation.
VDDADAC33	D10, E10, H10, J10,	I	Analog supply voltage. (3.3V)
VDDAPLL18	B10, B9	I	PLL analog supply voltage. (1.8V)
VDDAREF18	C10, K10	I	Analog reference supply voltage (1.8V)
VDDCLK09	A8, B8	I	Internal clock buffer supply voltage (0.9V). It is recommended to isolate this supply from VDDDIG09.
VDDDAC09	D9, E9, F9, G9, H9, J9	I	DAC core supply voltage. (0.9V). It is recommended to isolate this supply from VDDDIG09.
VDDDIG09	J7, J6, D5, J5, D4, E4, F4, G4, H4, J4, D3	I	Digital supply voltage. (0.9V). It is recommended to isolate this supply from VDDCLK09 and VDDDAC09.
VDDIO18	K7, K6	I	Supply voltage for all digital I/O and CMOS I/O. (1.8V)
VDDR18	F2, G2	I	Supply voltage for SerDes (1.8V)
VDDS18	C7, C6	I	Supply voltage for LVDS SYNCBP/N (1.8V)
VDDT09	F3, G3	I	Supply voltage for SerDes termination (0.9V)
VQPS18	D7, D6	I	Fuse supply voltage. This supply pin is also used for factory fuse programming. Connect to 1.8V.
VSENSE	C4	I/O	Analog test pin for on chip parameters.

ABSOLUTE MAXIMUM RATINGS

over operating free-air temperature range (unless otherwise noted)⁽¹⁾

		VALUE	UNIT
Supply Voltage Range ⁽²⁾	VDDDAC09, VDDDIG09	-0.5 to 1.1	V
	VDDCLK09	-0.5 to 1.1	V
	VDDT09	-0.5 to 1.1	V
	VDDR18, VDDIO, VDDS18, VQPS18	-0.5 to 1.89	V
	VDDAPLL18, VDDAREF18	-0.5 to 1.89	V
	VDDADAC33	-0.5 to 3.63	V
Pin Voltage Range ⁽²⁾	RX[7..0]P/N	-0.5 V to VDDT09 + 0.5 V	V
	SDENB, SCLK, SDIO, SDO, TXENA, ALARM, RESETB, SLEEP, TMS, TCLK, TDI, TDO, TRSTB, TESTMODE, SYNC_N_AB, SYNC_N_CD	-0.5 V to VDDIO18 + 0.5 V	V
	DACCLKP/N, SYSREFP/N	-0.5 V to VDDAPLL18 + 0.5 V	
	SYNCBP/N	-0.5 V to VDDS18 + 0.5 V	V
	PLLLPF	-0.5 V to VDDAPLL18 + 0.5 V	
	IOUTAP/N, IOUTBP/N, IOUTCP/N, IOUTDP/N	-0.5 V to VDDADAC33 + 0.5 V	V
	RBIAS, EXTIO, ATEST	-0.5 V to VDDAREF18 + 0.5 V	V
	IFORCE, VSENSE	-0.5 V to VDDDIG09 + 0.5 V	V
AMUX1, AMUX0	-0.5 V to VDDT09 + 0.5 V	V	
Peak input current (any input)		20	mA
Peak total input current (all inputs)		30	mA
Absolute maximum junction temperature T _J		150	°C
Operating free-air temperature range, T _A : DAC37J82/DAC38J82		-40 to 85	°C
Storage temperature range		-65 to 150	°C
Lead temperature 1,6 mm (1/16 inch) from the case for 10 seconds		260	°C

- (1) Stresses beyond those listed under absolute maximum ratings may cause permanent damage to the device. These are stress ratings only and functional operation of these or any other conditions beyond those indicated under “recommended operating conditions” is not implied. Exposure to absolute-maximum-rated conditions for extended periods may affect device reliability.
- (2) Measured with respect to GND.

THERMAL INFORMATION

THERMAL CONDUCTIVITY ^{(1) (2)}		144-Ball BGA	UNIT
θ _{JA}	Theta junction-to-ambient (still air)	31.4	°C/W
θ _{JB}	Theta junction-to-board	12.6	
θ _{JC}	Theta junction-to-case, top	1.8	
ψ _{JT}	Psi junction-to-top of package	0.2	
ψ _{JB}	Psi junction-to-bottom of package	12	

- (1) Air flow or heat sinking reduces θ_{JA} and may be required for sustained operation at 85° and maximum operating conditions.
- (2) It is strongly recommended to solder the device thermal pad to the board ground plane.

RECOMMENDED OPERATING CONDITIONS

		MIN	NOM	MAX	UNIT
T _J	Recommended operating junction temperature ⁽¹⁾			105	°C
	Maximum rated operating junction temperature	125			°C
T _A	Recommended free-air temperature	-40	25	85	°C

- (1) Prolonged use at this junction temperature may increase the device failure-in-time (FIT) rate.

ELECTRICAL CHARACTERISTICS - DC SPECIFICATIONS (to be Verified)

 Typical values at $T_A = 25^\circ\text{C}$, full temperature range is $T_{\text{MIN}} = -40^\circ\text{C}$ to $T_{\text{MAX}} = 85^\circ\text{C}$, nominal supplies, unless otherwise noted.

PARAMETER	TEST CONDITIONS	DAC37J82			DAC38J82			UNIT		
		MIN	TYP	MAX	MIN	TYP	MAX			
Resolution		16			16			Bits		
DC ACCURACY										
DNL	Differential nonlinearity	1 LSB = $I_{\text{OUTFS}}/2^{16}$			± 2			LSB		
INL	Integral nonlinearity				± 4			LSB		
ANALOG OUTPUT										
	Coarse gain linearity				± 0.04			LSB		
	Offset error	Mid code offset			± 0.001			%FSR		
	Gain error	With external reference			± 2			%FSR		
		With internal reference			± 2			%FSR		
	Gain mismatch	With internal reference			± 2			%FSR		
	Full scale output current				20	30	20	30	mA	
	Output compliance range				-0.5	0.6	-0.5	0.6	V	
	Output resistance				300			k Ω		
	Output capacitance				5			pF		
REFERENCE OUTPUT										
V_{REF}	Reference output voltage				0.9			V		
	Reference output current ⁽¹⁾				100			nA		
REFERENCE INPUT										
V_{EXTIO}	Input voltage range	External Reference Mode		0.1	0.9	1	0.1	0.9	1	V
	Input resistance				1			M Ω		
	Input capacitance				50			pF		
TEMPERATURE COEFFICIENTS										
	Offset drift				± 1			Ppm/ $^\circ\text{C}$		
	Gain drift	with external reference			± 15			ppm/ $^\circ\text{C}$		
		with internal reference			± 30			ppm/ $^\circ\text{C}$		
	Reference voltage drift				± 8			ppm/ $^\circ\text{C}$		
POWER SUPPLY										
	VDDDAC33				3.3			V		
	VDDAPLL18, VDDAREF18, VDDS18, VQPS18, VDDR18				1.8			V		
	VDDIO18				1.8			V		
	VDDDIG09, VDDDAC09, VDDCLK09, VDDT09				0.9			V		
PSRR	Power Supply Rejection Ratio	DC tested		± 0.2			± 0.2		%FSR/V	

(1) Use an external buffer amplifier with high impedance input to drive any external load

ELECTRICAL CHARACTERISTICS – DC SPECIFICATIONS (to be verified)

Typical values at $T_A = 25^\circ\text{C}$, full temperature range is $T_{\text{MIN}} = -40^\circ\text{C}$ to $T_{\text{MAX}} = 85^\circ\text{C}$, nominal supplies, unless otherwise noted.

PARAMETER	TEST CONDITIONS	DAC37J82			DAC38J82			UNIT
		MIN	TYP	MAX	MIN	TYP	MAX	
POWER CONSUMPTION								
$I_{\text{VDDADAC33}}$	Analog supply current	MODE 1:(DAC38J82)			64			mA
I_{VDDDIG09}	Digital supply current	$f_{\text{DAC}}=2.46\text{GSPS}$, 2x interpolation, NCO on, QMC on, inverse sinc on, GDC off, PAP off, PLL on, LMF=421,			628			
I_{VDDDAC09}	DAC supply current	SerDes rate = 12.3GSPS, 20mA FS output,			13			
I_{VDDCLK09}	Clock supply current	IF=150MHz.			86			
I_{VDDT09}	SerDes core supply current				168			
I_{VDDR18}	SerDes analog supply current				18			
I_{VDD18}	Other 1.8V supply current				53			
P	Power Dissipation				1144			
$I_{\text{VDDADAC33}}$	Analog supply current	MODE 2: (DAC37J82)			64			mA
I_{VDDDIG09}	Digital supply current	$f_{\text{DAC}}=1.6\text{GSPS}$, 2x interpolation, NCO on, QMC on, invsinc on, GDC off, PAP off, PLL on, LMF=421,			418			
I_{VDDDAC09}	DAC supply current	SerDes rate = 8GSPS, 20mA FS output, IF=150MHz.			10			
I_{VDDCLK09}	Clock supply current				57			
I_{VDDT09}	SerDes core supply current				139			
I_{VDDR18}	SerDes analog supply current				12			
I_{VDD18}	Other 1.8V supply current				50			
P	Power Dissipation				884			
$I_{\text{VDDADAC33}}$	Analog supply current	MODE 3:			64			mA
I_{VDDDIG09}	Digital supply current	$f_{\text{DAC}}=1.47456\text{GSPS}$, 2x interpolation, NCO on, QMC off, invsinc off, GDC off, PAP off, PLL off, LMF=421,			363			
I_{VDDDAC09}	DAC supply current	SerDes rate = 7.3728GSPS, 20mA FS output, IF=150MHz.			10			
I_{VDDCLK09}	Clock supply current				50			
I_{VDDT09}	SerDes core supply current				135			
I_{VDDR18}	SerDes analog supply current				12			
I_{VDD18}	Other 1.8V supply current				30			
P	Power Dissipation				789			
$I_{\text{VDDADAC33}}$	Analog supply current	MODE 4:			64			mA
I_{VDDDIG09}	Digital supply current	$f_{\text{DAC}}=1.47456\text{GSPS}$, 4x interpolation, NCO on, QMC off, invsinc off, GDC off, PAP off, PLL off, LMF=222,			312			
I_{VDDDAC09}	DAC supply current	SerDes rate = 7.3728GSPS, 20mA FS output, IF=150MHz.			10			
I_{VDDCLK09}	Clock supply current				50			
I_{VDDT09}	SerDes core supply current				76			
I_{VDDR18}	SerDes analog supply current				12			
I_{VDD18}	Other 1.8V supply current				30			
P	Power Dissipation				690			
$I_{\text{VDDADAC33}}$	Analog supply current	MODE 5:			13			mA
I_{VDDDIG09}	Digital supply current	$f_{\text{DAC}}=1.47456\text{GSPS}$, x4, NCO off, QMC off, invsinc off, GDC off, PAP off,			263			
I_{VDDDAC09}	DAC supply current	PLL off, LMF=222, SerDes rate = 7.3728GSPS, DAC output in sleep mode.			8			
I_{VDDCLK09}	Clock supply current				50			
I_{VDDT09}	SerDes core supply current				76			
I_{VDDR18}	SerDes analog supply current				12			
I_{VDD18}	Other 1.8V supply current				26			
P	Power Dissipation				469			

PRODUCT PREVIEW

ELECTRICAL CHARACTERISTICS – DC SPECIFICATIONS (to be verified)

Typical values at $T_A = 25^\circ\text{C}$, full temperature range is $T_{\text{MIN}} = -40^\circ\text{C}$ to $T_{\text{MAX}} = 85^\circ\text{C}$, nominal supplies, unless otherwise noted.

PARAMETER	TEST CONDITIONS	DAC37J82			DAC38J82			UNIT
		MIN	TYP	MAX	MIN	TYP	MAX	
POWER CONSUMPTION								
$I_{\text{VDDADAC33}}$	Analog supply current	MODE 6:			64			mA
I_{VDDDIG09}	Digital supply current	$f_{\text{DAC}}=1000\text{MSPS}$, 2x interpolation, NCO off, QMC off, invsinc off,			257			
I_{VDDDAC09}	DAC supply current	GDC off, PAP off, PLL on,			8			
I_{VDDCLK09}	Clock supply current	LMF=222, SerDes rate = 10GSPS, 20mA FS output, IF=150MHz.			36			
I_{VDDT09}	SerDes core supply current				85			
I_{VDDR18}	SerDes analog supply current				15			
I_{VDD18}	Other 1.8V supply current				50			
P	Power Dissipation				676			
$I_{\text{VDDADAC33}}$	Analog supply current	MODE 7:			64			mA
I_{VDDDIG09}	Digital supply current	$f_{\text{DAC}}=1000\text{MSPS}$, 2x interpolation, NCO off, QMC off, invsinc off,			256			
I_{VDDDAC09}	DAC supply current	GDC off,			8			
I_{VDDCLK09}	Clock supply current	PAP off, PLL off, LMF=222, SerDes rate = 10GSPS,			35			
I_{VDDT09}	SerDes core supply current	20mA FS output, IF=150MHz.			85			
I_{VDDR18}	SerDes analog supply current				15			
I_{VDD18}	Other 1.8V supply current				29			
P	Power Dissipation				636			
$I_{\text{VDDADAC33}}$	Analog supply current	MODE 8:			64			mA
I_{VDDDIG09}	Digital supply current	$f_{\text{DAC}}=625\text{MSPS}$, 2x interpolation, NCO off, QMC off, invsinc off,			195			
I_{VDDDAC09}	DAC supply current	GDC off,			4			
I_{VDDCLK09}	Clock supply current	PAP off, PLL off, LMF=421, SerDes rate = 3.125GSPS,			22			
I_{VDDT09}	SerDes core supply current	20mA FS output, IF=20MHz.			119			
I_{VDDR18}	SerDes analog supply current				11			
I_{VDD18}	Other 1.8V supply current				25			
P	Power Dissipation				582			
$I_{\text{VDDADAC33}}$	Analog supply current	MODE 9:			64			mA
I_{VDDDIG09}	Digital supply current	$f_{\text{DAC}}=1.23\text{GSPS}$, no interpolation, NCO off, QMC off, invsinc off, GDC off,			311			
I_{VDDDAC09}	DAC supply current	PAP off, PLL off, LMF=421, SerDes rate = 12.3GSPS,			10			
I_{VDDCLK09}	Clock supply current	20mA FS output, IF=150MHz;			42			
I_{VDDT09}	SerDes core supply current				165			
I_{VDDR18}	SerDes analog supply current				18			
I_{VDD18}	Other 1.8V supply current				29			
P	Power Dissipation				771			
$I_{\text{VDDADAC33}}$	Analog supply current	MODE 10:			5			mA
I_{VDDDIG09}	Digital supply current	Power down mode, no clock, DAC in sleep mode,			76			
I_{VDDDAC09}	DAC supply current	SerDes in sleep mode			1			
I_{VDDCLK09}	Clock supply current				1			
I_{VDDT09}	SerDes core supply current				9			
I_{VDDR18}	SerDes analog supply current				0			
I_{VDD18}	Other 1.8V supply current				10			
P	Power Dissipation				112			

ELECTRICAL CHARACTERISTICS – DIGITAL SPECIFICATIONS (to be verified)

Typical values at $T_A = 25^\circ\text{C}$, full temperature range is $T_{\text{MIN}} = -40^\circ\text{C}$ to $T_{\text{MAX}} = 85^\circ\text{C}$, nominal supplies, unless otherwise noted.

PARAMETER	TEST CONDITIONS	DAC37J82			DAC38J82			UNIT
		MIN	TYP	MAX	MIN	TYP	MAX	
CML SerDes Inputs: RX[7:0]P/N								
V_{DIFF}	Receiver Input Amplitude	50		1200	50		1200	mV
V_{COM}	Input Common Mode (TERM=111)		600			600		mV
	Input Common Mode (TERM=001)		700			700		mV
	Input Common Mode (TERM=100)		0			0		mV
	Input Common Mode (TERM=101)		250			250		mV
Z_{DDIFF}	Internal differential termination		100		85	100	115	Ω
f_{DATA}	Serdes bit rate	0.78125		12.5	0.78125		12.5	Gbps
LVPECL Inputs: SYSREFP/N								
V_{COM}	Input common mode voltage		0.5			0.5		V
V_{IDPP}	Differential input peak-to-peak voltage	100	800		100	800		mV
Z_{T}	Internal termination		100			100		Ω
C_{L}	Input capacitance							pF
LVPECL Inputs: DACCLKP/N								
V_{COM}	Input common mode voltage		0.5			0.5		V
V_{IDPP}	Differential input peak-to-peak voltage	100	800		100	800		mV
Z_{T}	Internal termination		100			100		Ω
C_{L}	Input capacitance							pF
	Duty cycle	40%		60%	40%		60%	
f_{DACCLK}	DACCLKP/N Input Frequency			1.6			2.5	GHz
LVDS Outputs: SYNCBP/N								
V_{COM}	Output common mode voltage		1.2			1.2		V
Z_{T}	Internal termination		100			100		Ω
V_{OD}	Differential output voltage swing		0.5			0.5		V
CMOS interface: SDENB, SCLK, SDIO, SDO, TXENA, ALARM, RESETB, SLEEP, TMS, TCLK, TDI, TDO, TRSTB, TESTMODE, SYNC_N_AB, SYNC_N_CD								
V_{IH}	High-level input voltage		0.7 x VDDIO			0.7 x VDDIO		V
V_{IL}	Low-level input voltage		0.3 x VDDIO			0.3 x VDDIO		V
I_{IH}	High-level input current		-40	40		-40	40	nA
I_{IL}	Low-level input current		-40	40		-40	40	nA
C_{I}	CMOS Input capacitance		2			2		pF
V_{OH}	ALARM, SDO, SDIO, TDO	Iload = -100 μA	VDDIO - 0.2			VDDIO - 0.2		V
		Iload = -2 mA	0.8 x VDDIO			0.8 x VDDIO		V
V_{OL}	ALARM, SDO, SDIO, TDO	Iload = 100 μA		0.2		0.2		V
		Iload = 2 mA		0.5		0.5		V
DIGITAL INPUT TIMING SPECIFICATIONS								
Timing SYSREF input: DACCLKP/N rising edge latching (3)								
$t_{\text{s}}(\text{SYSREF})$	Setup time, SYSREFP/N valid to rising edge of DACCLKP/N		50			50		ps
$t_{\text{h}}(\text{SYSREF})$	Hold time, SYSREFP/N valid after rising edge of DACCLKP/N		50			50		ps

ELECTRICAL CHARACTERISTICS – DIGITAL SPECIFICATIONS (to be verified) (continued)

 Typical values at $T_A = 25^\circ\text{C}$, full temperature range is $T_{\text{MIN}} = -40^\circ\text{C}$ to $T_{\text{MAX}} = 85^\circ\text{C}$, nominal supplies, unless otherwise noted.

PARAMETER	TEST CONDITIONS	DAC37J82			DAC38J82			UNIT
		MIN	TYP	MAX	MIN	TYP	MAX	
TIMING SERIAL PORT								
$t_{s(\text{SDENB})}$	Setup time, SDENB to rising edge of SCLK		20		20			ns
$t_{s(\text{SDIO})}$	Setup time, SDIO valid to rising edge of SCLK		10		10			ns
$t_{h(\text{SDIO})}$	Hold time, SDIO valid to rising edge of SCLK		5		5			ns
$t_{(\text{SCLK})}$	Period of SCLK	Register config7 read (temperature sensor read)	1		1			μs
		All other registers	100		100			ns
$t_{d(\text{Data})}$	Data output delay after falling edge of SCLK			10		10		ns
t_{RESET}	Minimum RESETB pulsewidth			25		25		ns

ELECTRICAL CHARACTERISTICS – AC SPECIFICATIONS (to be verified)

 Typical values at $T_A = 25^\circ\text{C}$, full temperature range is $T_{\text{MIN}} = -40^\circ\text{C}$ to $T_{\text{MAX}} = 85^\circ\text{C}$, nominal supplies, unless otherwise noted.

PARAMETER	TEST CONDITIONS / COMMENTS	DAC37J82			DAC38J82			UNIT
		MIN	TYP	MAX	MIN	TYP	MAX	
ANALOG OUTPUT ⁽¹⁾								
f_{DAC}	Maximum DAC rate	4x or higher interpolation	1600		2500			MSPS
		2x interpolation	1600		2460			MSPS
		1x interpolation	1230		1230			MSPS
$t_{s(\text{DAC})}$	Output settling time to 0.1%	Transition: Code 0x0000 to 0xFFFF			10		10	ns
t_{pd}	Output propagation delay	DAC outputs are updated on the falling edge of DAC clock. Does not include Digital Latency (see below).			2		2	ns
$t_{r(\text{IOUT})}$	Output rise time 10% to 90%		50		50			ps
$t_{f(\text{IOUT})}$	Output fall time 90% to 10%		50		50			ps
Digital Latency (F=2, 2x interpolation)		No interpolation, FIFO off, Mixer off, QMC off, Inverse sinc off	11		11			DAC clock cycles
		2x Interpolation	83		83			
		4x Interpolation	211		211			
		8x Interpolation	483		483			
		16x Interpolation	1051		1051			
		Fine Mixer	48		48			
		QMC	32		32			
		Inverse Sinc	36		36			
		PA Protection (<i>pap_dlyten_sel</i> = "0")	68		68			
		Dithering	0		0			
		Complex Summation	0		0			
		Coarse Fractional Delay	51		51			
Fine Fractional Delay	52		52					
Power-up Time	DAC Wake-up Time	IOUT current settling to 1% of IOUT _{FS} from deep sleep			90		90	μs
	DAC Sleep Time	IOUT current settling to less than 1% of IOUT _{FS} in deep sleep			90		90	

 (1) Measured single ended into 50 Ω load.

ELECTRICAL CHARACTERISTICS – AC SPECIFICATIONS (to be verified) (continued)

Typical values at $T_A = 25^\circ\text{C}$, full temperature range is $T_{\text{MIN}} = -40^\circ\text{C}$ to $T_{\text{MAX}} = 85^\circ\text{C}$, nominal supplies, unless otherwise noted.

PARAMETER	TEST CONDITIONS / COMMENTS	DAC37J82			DAC38J82			UNIT
		MIN	TYP	MAX	MIN	TYP	MAX	
AC PERFORMANCE ⁽²⁾								
SFDR	Spurious Free Dynamic Range (0 to $f_{\text{DAC}}/2$)	$f_{\text{DAC}} = 2.5 \text{ GSPS}, f_{\text{OUT}} = 20 \text{ MHz}, 0 \text{ dBFS}$	-	-	-	80	dBc	
		$f_{\text{DAC}} = 2.5 \text{ GSPS}, f_{\text{OUT}} = 70 \text{ MHz}, 0 \text{ dBFS}$	-	-	-	77		
		$f_{\text{DAC}} = 2.5 \text{ GSPS}, f_{\text{OUT}} = 150 \text{ MHz}, 0 \text{ dBFS}$	-	-	-	70		
		$f_{\text{DAC}} = 2.5 \text{ GSPS}, f_{\text{OUT}} = 230 \text{ MHz}, 0 \text{ dBFS}$	-	-	-	66		
		$f_{\text{DAC}} = 2.5 \text{ GSPS}, f_{\text{OUT}} = 20 \text{ MHz}, -12 \text{ dBFS}$	-	-	-	73		
		$f_{\text{DAC}} = 2.5 \text{ GSPS}, f_{\text{OUT}} = 70 \text{ MHz}, -12 \text{ dBFS}$	-	-	-	70		
		$f_{\text{DAC}} = 2.5 \text{ GSPS}, f_{\text{OUT}} = 150 \text{ MHz}, -12 \text{ dBFS}$	-	-	-	67		
		$f_{\text{DAC}} = 2.5 \text{ GSPS}, f_{\text{OUT}} = 230 \text{ MHz}, -12 \text{ dBFS}$	-	-	-	63		
		$f_{\text{DAC}} = 1.6 \text{ GSPS}, f_{\text{OUT}} = 20 \text{ MHz}, 0 \text{ dBFS}$	84	-	-	84		
		$f_{\text{DAC}} = 1.6 \text{ GSPS}, f_{\text{OUT}} = 70 \text{ MHz}, 0 \text{ dBFS}$	78	-	-	78		
		$f_{\text{DAC}} = 1.6 \text{ GSPS}, f_{\text{OUT}} = 150 \text{ MHz}, 0 \text{ dBFS}$	73	-	-	73		
		$f_{\text{DAC}} = 1.6 \text{ GSPS}, f_{\text{OUT}} = 230 \text{ MHz}, 0 \text{ dBFS}$	68	-	-	68		
		$f_{\text{DAC}} = 1.6 \text{ GSPS}, f_{\text{OUT}} = 20 \text{ MHz}, -12 \text{ dBFS}$	77	-	-	77		
		$f_{\text{DAC}} = 1.6 \text{ GSPS}, f_{\text{OUT}} = 70 \text{ MHz}, -12 \text{ dBFS}$	72	-	-	72		
		$f_{\text{DAC}} = 1.6 \text{ GSPS}, f_{\text{OUT}} = 150 \text{ MHz}, -12 \text{ dBFS}$	68	-	-	68		
		$f_{\text{DAC}} = 1.6 \text{ GSPS}, f_{\text{OUT}} = 230 \text{ MHz}, -12 \text{ dBFS}$	64	-	-	64		
IMD3	Third-order two-tone intermodulation distortion Each tone at -12 dBFS	$f_{\text{DAC}} = 2.5 \text{ GSPS}, f_{\text{OUT}} = 70 \pm 0.5 \text{ MHz}$	-	-	-	87	dBc	
		$f_{\text{DAC}} = 2.5 \text{ GSPS}, f_{\text{OUT}} = 150 \pm 0.5 \text{ MHz}$	-	-	-	79		
		$f_{\text{DAC}} = 2.5 \text{ GSPS}, f_{\text{OUT}} = 230 \pm 0.5 \text{ MHz}$	-	-	-	75		
		$f_{\text{DAC}} = 2.0 \text{ GSPS}, f_{\text{OUT}} = 70 \pm 0.5 \text{ MHz}$	-	-	-	86		
		$f_{\text{DAC}} = 2.0 \text{ GSPS}, f_{\text{OUT}} = 150 \pm 0.5 \text{ MHz}$	-	-	-	78		
		$f_{\text{DAC}} = 2.0 \text{ GSPS}, f_{\text{OUT}} = 230 \pm 0.5 \text{ MHz}$	-	-	-	73		
		$f_{\text{DAC}} = 1.6 \text{ GSPS}, f_{\text{OUT}} = 70 \pm 0.5 \text{ MHz}$	86	-	-	86		
		$f_{\text{DAC}} = 1.6 \text{ GSPS}, f_{\text{OUT}} = 150 \pm 0.5 \text{ MHz}$	77	-	-	77		
$f_{\text{DAC}} = 1.6 \text{ GSPS}, f_{\text{OUT}} = 230 \pm 0.5 \text{ MHz}$	71	-	-	71				
NSD	Noise Spectral Density ⁽²⁾ Tone at -7 dBFS	$f_{\text{DAC}} = 2.5 \text{ GSPS}, f_{\text{OUT}} = 70 \text{ MHz}$	-	-	-	-161	dBc/Hz	
		$f_{\text{DAC}} = 2.5 \text{ GSPS}, f_{\text{OUT}} = 150 \text{ MHz}$	-	-	-	-159		
		$f_{\text{DAC}} = 2.5 \text{ GSPS}, f_{\text{OUT}} = 230 \text{ MHz}$	-	-	-	-157		
		$f_{\text{DAC}} = 2.0 \text{ GSPS}, f_{\text{OUT}} = 70 \text{ MHz}$	-	-	-	-162		
		$f_{\text{DAC}} = 2.0 \text{ GSPS}, f_{\text{OUT}} = 150 \text{ MHz}$	-	-	-	-160		
		$f_{\text{DAC}} = 2.0 \text{ GSPS}, f_{\text{OUT}} = 230 \text{ MHz}$	-	-	-	-158		
		$f_{\text{DAC}} = 1.6 \text{ GSPS}, f_{\text{OUT}} = 70 \text{ MHz}$	-161	-	-	-161		
		$f_{\text{DAC}} = 1.6 \text{ GSPS}, f_{\text{OUT}} = 150 \text{ MHz}$	-159	-	-	-159		
		$f_{\text{DAC}} = 1.6 \text{ GSPS}, f_{\text{OUT}} = 230 \text{ MHz}$	-157	-	-	-157		
ACLR ⁽³⁾	Adjacent channel leakage ratio, single carrier	$f_{\text{DAC}} = 2.4576 \text{ GSPS}, f_{\text{OUT}} = 70 \text{ MHz}$	-	-	-	82	dBc	
		$f_{\text{DAC}} = 2.4576 \text{ GSPS}, f_{\text{OUT}} = 150 \text{ MHz}$	-	-	-	80		
		$f_{\text{DAC}} = 2.4576 \text{ GSPS}, f_{\text{OUT}} = 230 \text{ MHz}$	-	-	-	78		
		$f_{\text{DAC}} = 1.99608 \text{ GSPS}, f_{\text{OUT}} = 70 \text{ MHz}$	-	-	-	82		
		$f_{\text{DAC}} = 1.99608 \text{ GSPS}, f_{\text{OUT}} = 150 \text{ MHz}$	-	-	-	80		
		$f_{\text{DAC}} = 1.99608 \text{ GSPS}, f_{\text{OUT}} = 230 \text{ MHz}$	-	-	-	76		
		$f_{\text{DAC}} = 1.47456 \text{ GSPS}, f_{\text{OUT}} = 70 \text{ MHz}$	81	-	-	81		
		$f_{\text{DAC}} = 1.47456 \text{ GSPS}, f_{\text{OUT}} = 150 \text{ MHz}$	80	-	-	80		
		$f_{\text{DAC}} = 1.47456 \text{ GSPS}, f_{\text{OUT}} = 230 \text{ MHz}$	76	-	-	76		
Channel Isolation		$f_{\text{DAC}} = 2.5 \text{ GSPS}, f_{\text{OUT}} = 10 \text{ MHz}$	-	-	-	90	dBc	
		$f_{\text{DAC}} = 1.6 \text{ GSPS}, f_{\text{OUT}} = 10 \text{ MHz}$	90	-	-	90		

(2) 2:1 transformer output termination, 50 Ω doubly terminated load.

(3) Single carrier, W-CDMA with 3.84 MHz BW, 5-MHz spacing, centered at IF. TESTMODEL 1, 10 ms

TYPICAL PERFORMANCE PLOTS

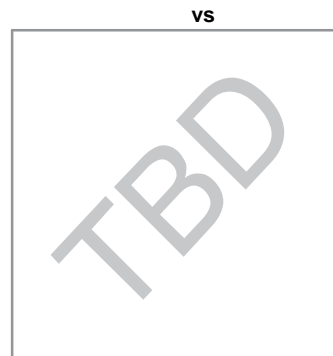
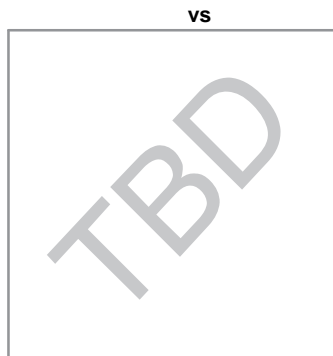
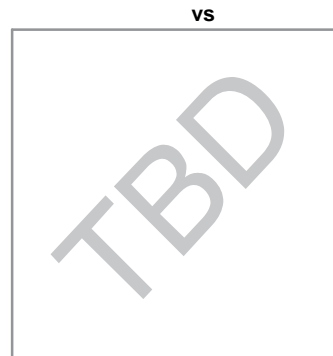
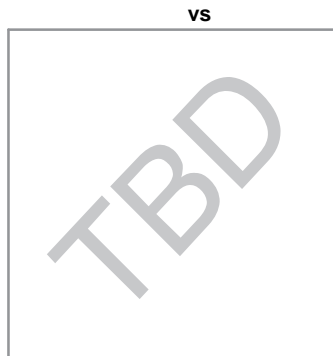

PRODUCT PREVIEW

SERDES INPUT

The RX [7:0]P/N differential inputs are each internally terminated to a common point via 50Ω, as shown in Figure 1.

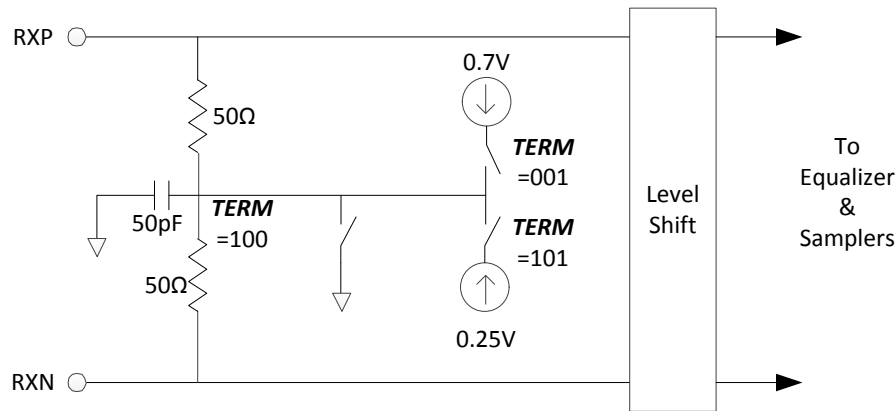

Figure 1. Serial Lane Input Termination

Common mode termination is via a 50pF capacitor to GND. The common mode voltage and termination of the differential signal can be controlled in a number of ways to suit a variety of applications via *mem_rw_cfgrx0* [10:8] (**TERM**), as described in Table 1.

(Note: AC coupling is recommended for JESD204B compliance.)

Table 2. Receiver Termination Selection

TERM	EFFECT
000	Reserved
001	Common point set to 0.7V. This configuration is for AC coupled systems. The transmitter has no effect on the receiver common mode, which is set to optimize the input sensitivity of the receiver.
01x	Reserved
100	Common point set to GND. This configuration is for applications that require a 0V common mode.
101	Common point set to 0.25V. This configuration is for applications that require a low common mode.
110	Reserved
111	Common point floating. This configuration is for DC coupled systems in which the common mode voltage is set by the attached transmit link partner to 0 and 0.6V. Note: this mode is not compatible with JESD204B.

Data input is sampled by the differential sensing amplifier using clocks derived from the clock recovery algorithm. The polarity of RXP and RXN can be inverted by setting the **INVPAIR** [7:0] bit of the corresponding lane to “1”. This can potentially simplify PCB layout and improve signal integrity by avoiding the need to swap over the differential signal traces.

Due to processing effects, the devices in the RXP and RXN differential sense amplifiers will not be perfectly matched and there will be some offset in switching threshold. DAC38J82/DAC37J82 family contains circuitry to detect and correct for this offset. This feature can be enabled by setting the *mem_rw_cfgrx0* [23] (**ENOC**) bit to “1”. It is anticipated the most users will enable this feature. During the compensation process, *mem_rw_cfgrx0* [25:24] (**LOOPBACK**) bit must be set to “00”.

Serdes Rate

DAC37J82/DAC38J82 has 8 configurable JESD204B serial lanes. The highest speed of each SerDes lane is 12.5Gbps. Because the primary operating frequency of the SerDes is determined by its reference clock and PLL multiplication factor, there is a limit on the lowest SerDes rate supported, please refer to Table 2 for details. To support lower speed application, each receiver should be configured to operate at half, quarter or eighth of the full rate via *mem_rw_cfgrx0* [6:5] (**RATE**).

Table 3. Lane Rate Selection

RATE	EFFECT
00	Full rate. Four data samples taken per SerDes PLL output clock cycle.
01	Half rate. Two data samples taken per SerDes PLL output clock cycle..
10	Quarter rate. One data samples taken per SerDes PLL output clock cycle.
11	Eighth rate. One data samples taken every two SerDes PLL output clock cycles.

Serdes PLL

DAC37J82/DAC38J82 has two integrated PLLs, one PLL is to provide the clocking of DAC, which will be discussed in a DAC PLL section; the other PLL is to provide the clocking for the high speed SerDes. The reference frequency of the SerDes PLL can be in the range of 100-800MHz nominal, and 300-800MHz optimal.

The reference frequency is derived from DACCLK divided down based on the *mem_serdes_refclk_div* programming, as shown in Figure 2.

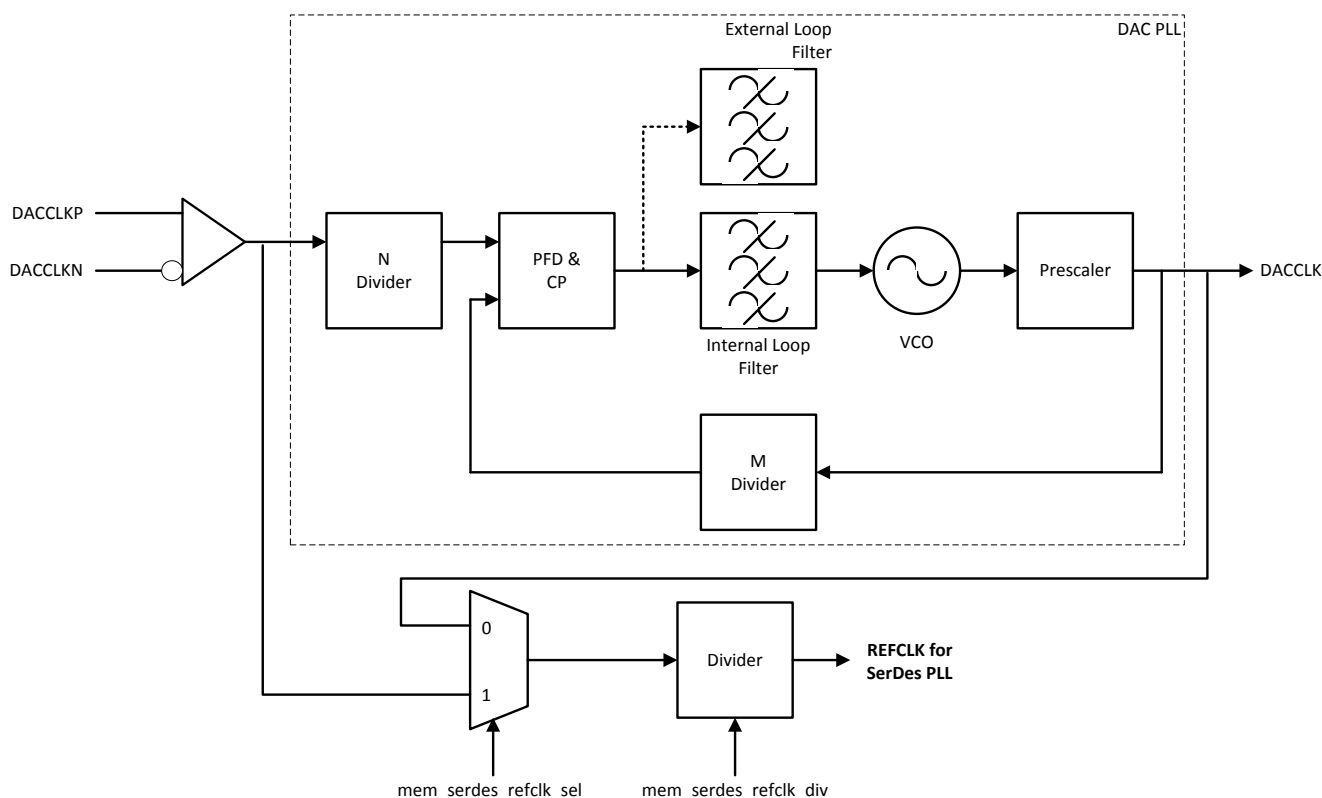

Figure 2. Reference Clock of SerDes PLL

During normal operation, the clock generated by PLL will be 4-25 times the reference frequency, according to the multiply factor selected via *mem_rw_cfgpll* [8:1] (MPY). In order to select the appropriate multiply factor and refclkp/n frequency, it is first necessary to determine the required PLL output clock frequency. The relationship between the PLL output clock frequency and the lane rate is shown in Table 3. Having computed the PLL output frequency, the reference frequency can be obtained by dividing this by the multiply factor specified via MPY.

Note that high multiplication factor settings will be especially sensitive to reference clock jitter, and should not be employed without prior consultation with TI.

PRODUCT PREVIEW

Table 4. Relationship Between Lane Rate and SerDes PLL Output Frequency

RATE	LINE RATE	PLL OUTPUT FREQUENCY
Full	x Gbps	0.25x GHz
Half	x Gbps	0.5x GHz
Quarter	x Gbps	x GHz
Eighth	x Gbps	2x GHz

Table 5. SerDes PLL Modes Selection

MPY	EFFECT
00010000	4x
00010100	5x
00011000	6x
00100000	8x
00100001	8.25x
00101000	10x
00110000	12x
00110010	12.5x
00111100	15x
01000000	16x
01000010	16.5x
01010000	20x
01011000	22x
01100100	25x
Other codes	reserved

The wide range of multiply factors combined with the different rate modes means it will often be possible to achieve a given line rate from multiple different reference frequencies. The configuration which utilizes the highest reference frequency achievable is always preferable.

The SerDes PLL VCO must be in the nominal range of 1.5625 - 3.125 GHz. It is necessary to adjust the loop filter depending on the operating frequency of the VCO. To indicate the selection the user must set the *mem_rw_cfgpll* [9] (**VRANGE**) bit. If the PLL output frequency is below 2.17GHz, **VRANGE** should be set high.

Performance of the integrated PLL can be optimized according to the jitter characteristics of the reference clock by setting the appropriate loop bandwidth via *mem_rw_cfgpll* [12:11] (**LB**) bits. The loop bandwidth is obtained by dividing the reference frequency by BWSCALE, where the BWSCALE is a function of both LB and PLL output frequency as shown in [Table 5](#).

Table 6. SerDes PLL Loop Bandwidth Selection

LB	EFFECT	BWSCALE vs PLL OUTPUT FREQUENCY		
		3.125 GHz	2.17 GHz	1.5625 GHz
00	Medium loop bandwidth	13	14	16
01	Ultra high loop bandwidth	7	8	8
10	Low loop bandwidth	21	23	30
11	High loop bandwidth	10	11	14

An approximate loop bandwidth of 8–30MHz is suitable and recommended for most systems where the reference clock is via low jitter clock input buffer. For systems where the reference clock is via a low jitter input cell, but of low quality, an approximate loop bandwidth of less than 8MHz may offer better performance. For systems where the reference clock is cleaned via an ultra low jitter LC-based cleaner PLL, a high loop bandwidth up to 60MHz is more appropriate. Note that the use of ultra high loop bandwidth setting is not recommended for PLL multiply factor of less than 8.

A free running clock output is available when *mem_rw_cfgpll* [15:14] (**ENDIVCLK**) is set high. It runs at a fixed divided-by-5 of the PLL output frequency and has a duty cycle of 50%. A divided-by-16 of this free running clock can be configured to come out the alarm pin during digital test, see *mem_dtest* [11:8] for the specific configuration needed.

SERDES EQUALIZER

All channels of the DAC37J82/DAC38J82 incorporate an adaptive equalizer, which can compensate for channel insertion loss by attenuating the low frequency components with respect to the high frequency components of the signal, thereby reducing inter-symbol interference. Figure 3 shows the response of the equalizer, which can be expressed in terms of the amount of low frequency gain and the frequency up to which this gain is applied (i.e., the frequency of the 'zero'). Above the zero frequency, the gain increases at 6dB/octave until it reaches the high frequency gain.

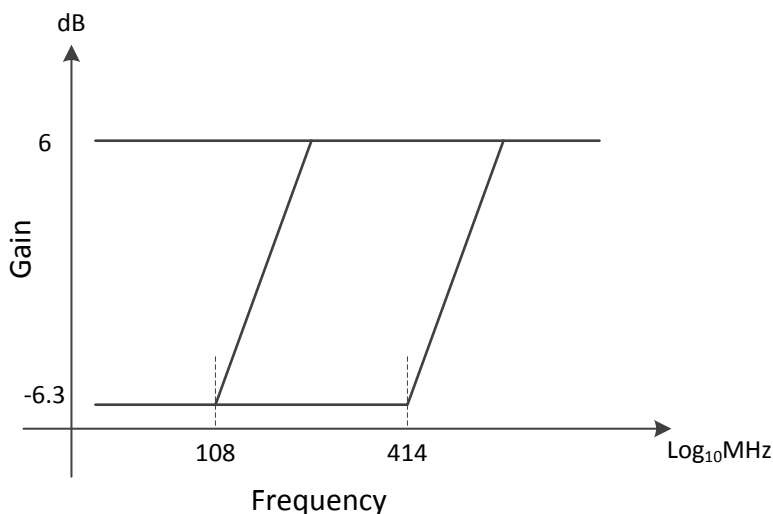

Figure 3. Equalizer Frequency Response

The equalizer can be configured via *mem_rw_cfgrx0*[21:19] (EQ) and *mem_rx_cfgrx0*[22] (EQHLD). Table 6 and Table 7 summarize the options. When enabled, the receiver equalization logic analyzes data patterns and transition times to determine whether the low frequency gain should be increased or decreased. The decision logic is implemented as a voting algorithm with a relatively long analysis interval. The slow time constant that results reduces the probability of incorrect decisions but allows the equalizer to compensate for the relatively stable response of the channel. The lock time for the adaptive equalizer is data dependent, and so it is not possible to specify a generally applicable absolute limit. However, assuming random data, the maximum lock time will be 6×10^6 divided by the CDR activity level. For CDR (*mem_rw_cfgrx0*[18:16]) = 110, this is 1.5×10^6 UI.

When EQ[2] = 0, finer control of gain boost is available using the EQBOOSTi IEEE1500 tuning chain field, as shown in Table 8.

Table 7. Receiver Equalization Configuration

EQ[1:0]	EFFECT
0	<i>No equalization.</i> The equalizer provides a flat response at the maximum gain. This setting may be appropriate if jitter at the receiver occurs predominantly as a result of crosstalk rather than frequency dependent loss.
1	<i>Fully adaptive equalization.</i> The zero position is determined by the selected operating rate, and the low frequency gain of the equalizer is determined algorithmically by analyzing the data patterns and transition positions in the received data. This setting should be used for most applications.
10	<i>Precursor equalization analysis.</i> The data patterns and transition positions in the received data are analyzed to determine whether the transmit link partner is applying more or less precursor equalization than necessary.
11	<i>Postcursor equalization analysis.</i> The data patterns and transition positions in the received data are analyzed to determine whether the transmit link partner is applying more or less postcursor equalization than necessary.

Table 7. Receiver Equalization Configuration (continued)

EQ[2]	EFFECT
0	Default
1	<i>Boost.</i> Equalizer gain boosted by 6dB, with a 20% reduction in bandwidth, and an increase of 5mW power consumption. May improve performance over long links.

Table 8. Receiver Equalizer Hold

EQHOLD	EFFECT
0	Equalizer adaption enabled. The equalizer adaption and analysis algorithm is enabled. This should be the default state.
1	Equalizer adaption held. The equalizer is held in it's current state. Additionally, the adaption and analysis algorithm is reset. See section 7.2.5.1 for further details..

Table 9. Receiver Equalizer Gain Boost

EQBoost VALUE	GAIN BOOST (dB)	BANDWIDTH CHANGE (%)	POWER INCREASE (mW)
0	0	0	0
1	2	-30	0
10	4	10	5
11	6	-20	5

When EQ is set to 010 or 011, the equalizer is reconfigured to provide analytical data about the amount of pre and post cursor equalization respectively present in the received signal. This can in turn be used to adjust the equalization settings of the transmitting link partner, where a suitable mechanism for communicating this data back to the transmitter exists. Status information is provided via *mem_dtest*[11:8] (EQOVER, EQUNDER), by using the following method:

1. Enable the equalizer by setting EQHLD low and EQ to 001. Allow sufficient time for the equalizer to adapt;
2. Set EQHLD to 1 to lock the equalizer and reset the adaption algorithm. This also causes both EQOVER and EQUNDER to become low;
3. Wait at least 48UI, and proportionately longer if the CDR activity is less than 100%, to ensure the 1 on EQHLD is sampled and acted upon;
4. Set EQ to 010 or 011, and EQHLD to 0. The equalization characteristics of the received signal are analysed (the equalizer response will continue to be locked);
5. Wait at least 150_103UI to allow time for the analysis to occur, proportionately longer if the CDR activity is less than 100%;
6. Examine EQOVER and EQUNDER for results of analysis.
 - If EQOVER is high, it indicates the signal is over equalized;
 - If EQUNDER is high, it indicates the signal is under equalized;
7. Set EQHLD to 1;
8. Repeat items 3–7 if required;
9. Set EQ to 001, and EQHLD to 0 to exit analysis mode and return to normal adaptive equalization.

Note that when changing EQ from one non-zero value to another, EQHLD must already be 1. If this is not the case, there is a chance the equalizer could be reset by a transitory input state (i.e., if EQ is momentarily 000). EQHLD can be set to 0 at the same time as EQ is changed.

As the equalizer adaption algorithm is designed to equalize the post cursor, EQOVER or EQUNDER will only be set during post cursor analysis if the amount of post cursor equalization required is more or less than the adaptive equalizer can provide.

JESD204B DESCRAMBLER

The descrambler is a 16-bit parallel self-synchronous descrambler based on the polynomial $1 + x^{14} + x^{15}$. From the JESD204B specification, the scrambling/descrambling process only occurs on the user data, not on the code group synchronization or the ILA sequence. The descrambler output can be selected to sent out during JESD test, see *mem_jesd_testbus_sel* for the specific configuration needed.

JESD204B FRAME ASSEMBLY

The JESD204B defines the following parameters:

- L is the number of lanes per link
- M is the number of converters per device
- F is the number of octets per frame clock period
- S is the number of samples per frame
- HD is the High-Density bit which controls whether a sample may be divided over more lanes.

Table 9 list the available JESD204B formats for the DAC37J82/DAC38J82. Table 10 and Table 11 list the speed limits of DAC38J82/DAC37J82. The ranges are limited by the Serdes PLL VCO frequency range, the Serdes PLL reference clock range, the maximum Serdes line rate, and the maximum DAC sample frequency.

Table 10. JESD204B Frame Assembly Byte Representation

	LMF = 821			LMF = 421				LMF = 222				LMF = 124							
Lane 0	I0[15:8]	I2[15:8]	I4[15:8]	I0[15:8]	I1[15:8]	I2[15:8]	I3[15:8]	I0[15:8]	I0[7:0]	I1[15:8]	I1[7:0]	I0[15:8]	I0[7:0]	Q0[15:8]	Q0[7:0]	I1[15:8]	I1[7:0]	Q1[15:8]	Q1[7:0]
Lane 1	I0[7:0]	I2[7:0]	I4[7:0]	I0[7:0]	I1[7:0]	I2[7:0]	I3[7:0]	Q0[15:8]	Q0[15:8]	Q0[7:0]	Q1[15:8]	Q1[15:8]	Q1[7:0]						
Lane 2	I1[15:8]	I3[15:8]	I5[15:8]	Q0[15:8]	Q1[15:8]	Q2[15:8]	Q3[15:8]												
Lane 3	I1[7:0]	I3[7:0]	I5[7:0]	Q0[7:0]	Q1[7:0]	Q2[7:0]	Q3[7:0]												
Lane 4	Q0[15:8]	Q2[15:8]	Q4[15:8]																
Lane 5	Q0[7:0]	Q2[7:0]	Q4[7:0]																
Lane 6	Q1[15:8]	Q3[15:8]	Q5[15:8]																
Lane 7	Q1[7:0]	Q3[7:0]	Q5[7:0]																

Table 11. DAC38J82 Speed Limits

L	M	F	S	HD	Interpolation	Min f_{SERDES} (Gbps)	Max f_{SERDES} (Gbps)	Min f_{DATA} (MSPS)	Max f_{DATA} (MSPS)	Min f_{DAC} (MSPS)	Max f_{DAC} (MSPS)	Max BW (MHz)
8	2	1	2	1	1	0.78125	6.15	156.25	1230	156.25	1230	1230
					2	0.78125	6.15	156.25	1230	312.5	2460	984
					4	0.78125	3.125	156.25	625	625	2500	500
					8	0.78125	1.5625	156.25	312.5	1250	2500	250
					16	N/A	N/A	N/A	N/A	N/A	N/A	N/A
4	2	1	1	1	1	1	12.3	100	1230	100	1230	1230
					2	0.78125	12.3	78.125	1230	156.25	2460	984
					4	0.78125	6.25	78.125	625	312.5	2500	500
					8	0.78125	3.125	78.125	312.5	625	2500	250
					16	0.78125	1.5625	78.125	156.25	1250	2500	125
2	2	2	1	0	1	2	12.5	100	625	100	625	625
					2	1	12.5	50	625	100	1250	500
					4	0.78125	12.5	39.0625	625	156.25	2500	500
					8	0.78125	6.25	39.0625	312.5	312.5	2500	250
					16	0.78125	3.125	39.0625	156.25	625	2500	125
1	2	4	1	0	1	N/A	N/A	N/A	N/A	N/A	N/A	N/A
					2	2	12.5	50	312.5	100	625	250
					4	1.5625	12.5	39.0625	312.5	156.25	1250	250
					8	1.5625	12.5	39.0625	312.5	312.5	2500	250
					16	1.5625	6.25	39.0625	156.25	625	2500	125

L = # of lanes
M = # of DACs
F = # of Octets per lane per frame cycle
S = # of Samples per DAC per frame cycle
HD = High density mode
 f_{SERDES} = Serdes line rate
 f_{DATA} = Input data rate per DAC
 f_{DAC} = Output sample rate
BW = Complex bandwidth (= $f_{DATA} \times 0.8$ with interpolation, = f_{DATA} without interpolation)

PRODUCT PREVIEW

Table 12. DAC37J82 Speed Limits

L	M	F	S	HD	Interpolation	Min f_{SERDES} (Gbps)	Max f_{SERDES} (Gbps)	Min f_{DATA} (MSPS)	Max f_{DATA} (MSPS)	Min f_{DAC} (MSPS)	Max f_{DAC} (MSPS)	Max BW (MHz)
8	2	1	2	1	1	0.78125	6.15	156.25	1230	156.25	1230	1230
					2	0.78125	4	156.25	800	312.5	1600	640
					4	0.78125	2	156.25	400	625	1600	320
					8	0.78125	1	156.25	200	1250	1600	160
					16	N/A	N/A	N/A	N/A	N/A	N/A	N/A
4	2	1	1	1	1	1	12.3	100	1230	100	1230	1230
					2	0.78125	8	78.125	800	156.25	1600	640
					4	0.78125	4	78.125	400	312.5	1600	320
					8	0.78125	2	78.125	200	625	1600	160
					16	0.78125	1	78.125	100	1250	1600	80
2	2	2	1	0	1	2	12.5	100	625	100	625	625
					2	1	12.5	50	625	100	1250	500
					4	0.78125	8	39.0625	400	156.25	1600	320
					8	0.78125	4	39.0625	200	312.5	1600	160
					16	0.78125	2	39.0625	100	625	1600	80
1	2	4	1	0	1	N/A	N/A	N/A	N/A	N/A	N/A	N/A
					2	2	12.5	50	312.5	100	625	250
					4	1.5625	12.5	39.0625	312.5	156.25	1250	250
					8	1.5625	8	39.0625	200	312.5	1600	160
					16	1.5625	4	39.0625	100	625	1600	80

L = # of lanes

M = # of DACs

F = # of Octets per lane per frame cycle

S = # of Samples per DAC per frame cycle

HD = High density mode

 f_{SERDES} = Serdes line rate

 f_{DATA} = Input data rate per DAC

 f_{DAC} = Output sample rate

 BW = Complex bandwidth (= $f_{DATA} \times 0.8$ with interpolation, = f_{DATA} without interpolation)

SERIAL PERIPHERAL INTERFACE (SPI)

The serial port of the DAC37J82/DAC38J82 is a flexible serial interface which communicates with industry standard microprocessors and microcontrollers. The interface provides read/write access to all registers used to define the operating modes of DAC37J82/DAC38J82. It is compatible with most synchronous transfer formats and can be configured as a 3 or 4 pin interface by *sif4_ena* in register *config2*. In both configurations, SCLK is the serial interface input clock and SDENB is serial interface enable. For 3 pin configuration, SDIO is a bidirectional pin for both data in and data out. For 4 pin configuration, SDIO is bidirectional and SDO is data out only. Data is input into the device with the rising edge of SCLK. Data is output from the device on the falling edge of SCLK.

Each read/write operation is framed by signal SDENB (Serial Data Enable Bar) asserted low. The first frame byte is the instruction cycle which identifies the following data transfer cycle as read or write as well as the 7-bit address to be accessed. [Table 12](#) indicates the function of each bit in the instruction cycle and is followed by a detailed description of each bit. The data transfer cycle consists of two bytes.

Table 13. Instruction Byte of the Serial Interface

	MSB							LSB
Bit	7	6	5	4	3	2	1	0
Description	R/W	A6	A5	A4	A3	A2	A1	A0

R/W Identifies the following data transfer cycle as a read or write operation. A high indicates a read operation from DAC37J82/DAC38J82 and a low indicates a write operation to DAC37J82/DAC38J82.

[A6 : A0] Identifies the address of the register to be accessed during the read or write operation.

[Figure 4](#) shows the serial interface timing diagram for a DAC37J82/DAC38J82 write operation. SCLK is the serial interface clock input to DAC37J82/DAC38J82. Serial data enable SDENB is an active low input to DAC37J82/DAC38J82. SDIO is serial data in. Input data to DAC37J82/DAC38J82 is clocked on the rising edges of SCLK.

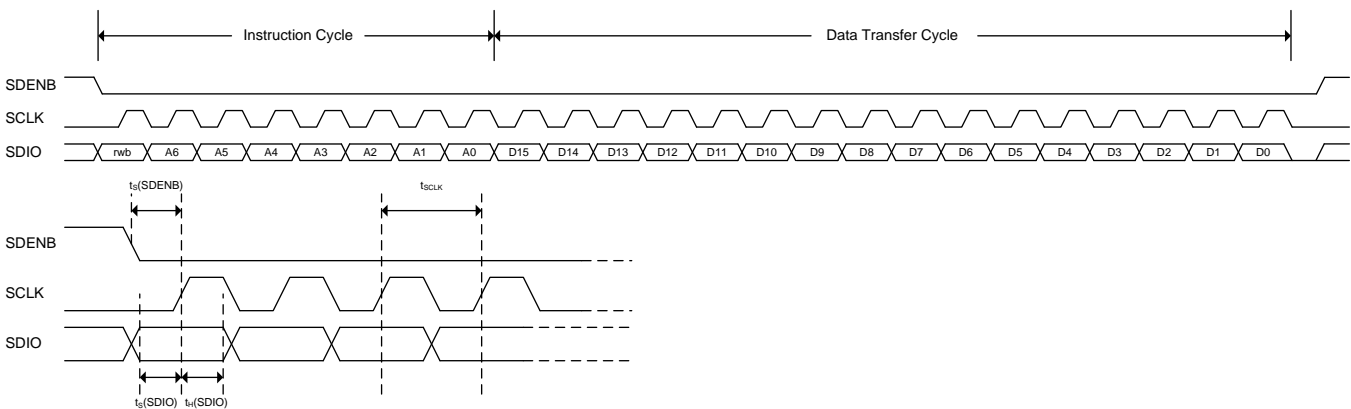

Figure 4. Serial Interface Write Timing Diagram

[Table 13](#) shows the serial interface timing diagram for a DAC37J82/DAC38J82 read operation. SCLK is the serial interface clock input to DAC37J82/DAC38J82. Serial data enable SDENB is an active low input to DAC37J82/DAC38J82. SDIO is serial data in during the instruction cycle. In 3 pin configuration, SDIO is data out from the DAC37J82/DAC38J82 during the data transfer cycle, while SDO is in a high-impedance state. In 4 pin configuration, both SDIO and SDO are data out from the DAC37J82/DAC38J82 during the data transfer cycle. At the end of the data transfer, SDIO and SDO will output low on the final falling edge of SCLK until the rising edge of SDENB when they will 3-state.

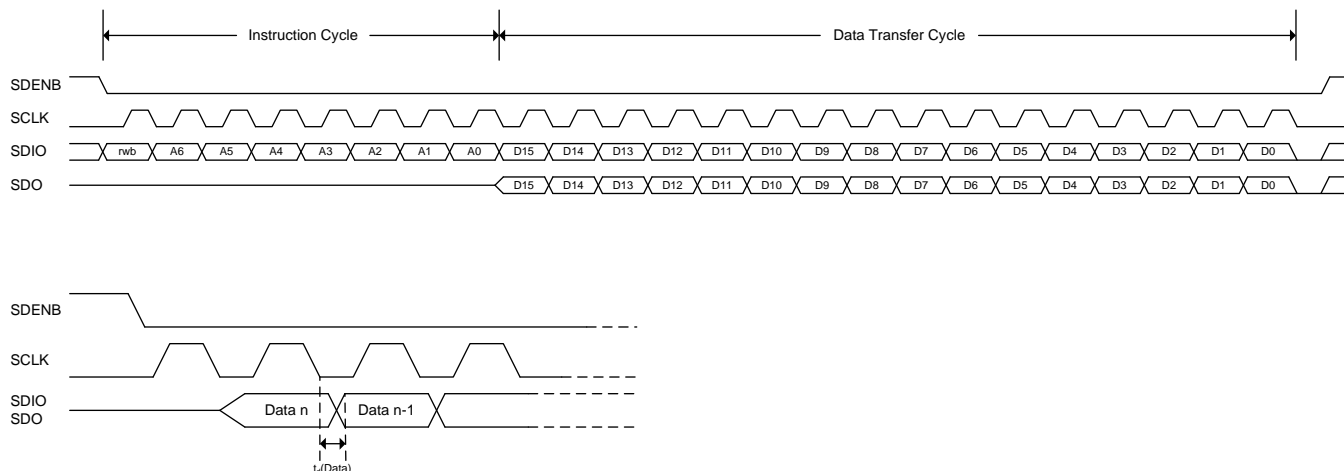

Figure 5. Serial Interface Read Timing Diagram

In the SIF interface there are four types of registers:

- **NORMAL:** The NORMAL register type allows data to be written and read from. All 16-bits of the data are registered at the same time. There is no synchronizing with an internal clock thus all register writes are asynchronous with respect to internal clocks. There are three subtypes of NORMAL:
 - **AUTOSYNC:** A NORMAL register that causes a sync to be generated after the write is finished. These are used when it is desirable to synchronize the block after writing the register or in the case of a single field that spans across multiple registers. For instance, the NCO requires three 16-bit register writes to set the frequency. Upon writing the last of these registers an autosync is generated to deliver the entire field to the NCO block at once, rather than in pieces after each individual register write. For a field that spans multiple registers, all non-AUTOSYNC registers for the field must be written first before the actual AUTOSYNC register.
 - **No RESET Value:** These are NORMAL registers, but the reset value **cannot** be guaranteed. This could be because the register has some read_only bits or some internal logic partially controls the bit values.
- **READ_ONLY:** Registers that can be read from but not written to.
- **WRITE_TO_CLEAR:** These registers are just like NORMAL registers with one exception. They can be written and read, however, when the internal logic asynchronously sets a bit high in one of these registers, that bit stays high until it is written to '0'. This way interrupts will be captured and stay constant until cleared by the user. In DAC37J82/DAC38J82, register *config100-108* are WRTE_TO_CLEAR registers.

Table 14. Register Map

Name	Address	Default	(MSB) Bit 15	Bit 14	Bit 13	Bit 12	Bit 11	Bit 10	Bit 9	Bit 8	Bit 7	Bit 6	Bit 5	Bit 4	Bit 3	Bit 2	Bit 1	(LSB) Bit 0	
config0	0x00	0x0218	qmc_offsetab_ena	qmc_offsetcd_ena	qmc_corrab_ena	qmc_corrccd_ena	interp(3:0)					alarm_zer_ostxenable_ena	outsum_ena	alarm_zeros_jesd_data_ena	alarm_out_ena	alarm_out_pol	pap_ena	inv_sinc_ab_ena	inv_sinc_cd_ena
config1	0x01	0x0003	sfrac_ena_ab	sfrac_ena_cd	lfrac_ena_ab	lfrac_ena_cd	sfrac_sel_ab	sfrac_sel_cd	reserved	reserved	daca_compliment	dacb_compliment	dacc_compliment	dacd_compliment	reserved	reserved	reserved	reserved	
config2	0x02	0x2002	dac_bitwidth(1:0)		zer_invalid_data	shorttest_ena	reserved	reserved	reserved	reserved	sif4_ena	mixer_ena	mixer_gain	nco_ena	reserved	reserved	twos	sif_reset	
config3	0x03	0xF380	coarse_dac(3:0)				reserved					fif_error_zeros_data_ena	reserved					sif_tenable	
config4	0x04	0x00FF	alarms_mask(15:0)																
config5	0x05	0xFFFF	alarms_mask(31:16)																
config6	0x06	0xFFFF	alarms_mask(47:32)																
config7	0x07	0x0000	memin_tempdata(7:0)								reserved				memin_lane_skew(4:0)				
config8	0x08	0x0000	reserved	reserved	reserved	qmc_offseta(12:0)													
config9	0x09	0x0000	reserved	reserved	reserved	qmc_offsetb(12:0)													
config10	0x0A	0x0000	reserved	reserved	reserved	qmc_offsetc(12:0)													
config11	0x0B	0x0000	reserved	reserved	reserved	qmc_offsetd(12:0)													
config12	0x0C	0x0400	reserved	reserved	reserved	reserved	reserved	qmc_gaina(10:0)											
config13	0x0D	0x0400	fs8	fs4	fs2	fsm4	reserved	qmc_gainb(10:0)											
config14	0x0E	0x0400	reserved	reserved	reserved	reserved	reserved	qmc_gainc(10:0)											
config15	0x0F	0x0400	output_delayab_reserved(1:0)		output_delaycd_reserved(1:0)		reserved	qmc_gaind(10:0)											
config16	0x10	0x0000	reserved	reserved	reserved	reserved	qmc_phaseab(11:0)												
config17	0x11	0x0000	reserved	reserved	reserved	reserved	qmc_phasecd(11:0)												
config18	0x12	0x0000	phaseoffsetab(15:0)																
config19	0x13	0x0000	phaseoffsetcd(15:0)																
config20	0x14	0x0000	phaseaddab(15:0)																
config21	0x15	0x0000	phaseaddab(31:16)																
config22	0x16	0x0000	phaseaddab(47:32)																
config23	0x17	0x0000	phaseaddcd(15:0)																
config24	0x18	0x0000	phaseaddcd(31:16)																
config25	0x19	0x0000	phaseaddcd(47:32)																
config26	0x1A	0x0020	reserved						reserved	vbgr_sleep	biasopamp_sleep	tsense_sleep	pll_sleep	clkrecv_sleep	daca_sleep	dacb_sleep	dacc_sleep	dacd_sleep	
config27	0x1B	0x0000	extref_ena	dtest_lane(2:0)			dtest(3:0)				reserved	reserved	atest(5:0)						
config28	0x1C	0x0000	reserved																
config29	0x1D	0x0000	reserved																
config30	0x1E	0x1111	syncsel_qmoffsetab(3:0)				syncsel_qmoffsetcd(3:0)				syncsel_qmcorrab(3:0)				syncsel_qmcorrcd(3:0)				
config31	0x1F	0x1140	syncsel_mixerab(3:0)				syncsel_mixercd(3:0)				syncsel_nco(3:0)				reserved	sif_sync	reserved		

PRODUCT PREVIEW

Table 14. Register Map (continued)

Name	Address	Default	(MSB) Bit 15	Bit 14	Bit 13	Bit 12	Bit 11	Bit 10	Bit 9	Bit 8	Bit 7	Bit 6	Bit 5	Bit 4	Bit 3	Bit 2	Bit 1	(LSB) Bit 0
config32	0x20	0x0000	syncsel_dither(3:0)			reserved			syncsel_pap(3:0)			syncsel_fir5a(3:0)						
config33	0x21	0x0000	reserved															
config34	0x22	0x1B1B	patha_in_sel(1:0)		pathb_in_sel(1:0)		pathc_in_sel(1:0)		pathd_in_sel(1:0)		patha_out_sel(1:0)		pathb_out_sel(1:0)		pathc_out_sel(1:0)		pathd_out_sel(1:0)	
config35	0x23	0xFFFF	sleep_cntl(15:0)															
config36	0x24	0x0000	reserved						cdrvser_sysref_mode(2:0)			reserved		reserved				
config37	0x25	0x0000	clkjesd_div(2:0)			reserved			reserved			reserved			reserved		reserved	
config38	0x26		dither_ena(3:0)			dither_mixer_ena(3:0)			dither_sra_sel(3:0)			reserved		reserved	dither_zero			
config39	0x27	0x0000	reserved(15:0)															
config40	0x28	0x0000	reserved(15:0)															
config41	0x29	0x0000	reserved(15:0)															
config42	0x2A	0x0000	reserved(15:0)															
config43	0x2B	0x0000	reserved(15:0)															
config44	0x2C	0x0000	reserved(15:0)															
config45	0x2D	0x0000	reserved	reserved											pap_dlylen_sel	pap_gain(2:0)		
config46	0x2E	0xFFFF	pap_vth(15:0)															
config47	0x2F	0x0004	reserved	titest_dieid_read_ena	reserved	reserved									reserved	reserved	sifdac_ena	
config48	0x30	0x0000	sifdac(15:0)															
config49	0x31	0x0000	lockdet_adj(2:0)			pll_reset	pll_ndivsync_ena	pll_ena	pll_cp(1:0)		pll_n(4:0)				memin_pll_lfvolt(2:0)			
config50	0x32	0x0000	pll_m(7:0)							pll_p(3:0)			reserved					
config51	0x33	0x0100	pll_vcose	pll_vco(5:0)					pll_vcoitune(1:0)		pll_cp_adj(4:0)			reserved				
config52	0x34	0x0000	syncb_lvds_lopwrb	syncb_lvds_lopwra	syncb_lvds_lpsel	syncb_lvds_effuse_sel	reserved		reserved	lvds_sleep	lvds_sub_ena	reserved(6:0)						
config53	0x35	0x0000	reserved			reserved			reserved			reserved			reserved			
config54	0x36	0x0000	reserved															
config55	0x37	0x0000	reserved															
config56	0x38	0x0000	reserved															
config57	0x39	0x0000	reserved															
config58	0x3A	0x0000	reserved															
config59	0x3B	0x0000	serdes_clk_sel	serdes_refclk_div(3:0)				reserved						reserved				
config60	0x3C	0x0000	rw_cfgpll(15:0)															
config61	0x3D	0x0000	reserved	rw_cfggrx0(14:0)														
config62	0x3E	0x0000	rw_cfggrx0(15:0)															
config63	0x3F	0x0000	reserved								INVPAIR(7:0)							
config64	0x40	0x0000	reserved															
config65	0x41	0x0000	errorcnt_link0(15:0)															
config66	0x42	0x0000	errorcnt_link1(15:0)															

Table 14. Register Map (continued)

Name	Address	Default	(MSB) Bit 15	Bit 14	Bit 13	Bit 12	Bit 11	Bit 10	Bit 9	Bit 8	Bit 7	Bit 6	Bit 5	Bit 4	Bit 3	Bit 2	Bit 1	(LSB) Bit 0
config67	0x43	0x0000	errorcnt_link2(15:0)															
config68	0x44	0x0000	errorcnt_link3(15:0)															
config69	0x45	0x0000	reserved															
config70	0x46	0x0044	lid0(4:0)				lid1(4:0)				lid2(4:0)				reserved			
config71	0x47	0x190A	lid3(4:0)				lid4(4:0)				lid5(4:0)				reserved			
config72	0x48	0x31C3	lid6(4:0)				lid7(4:0)				reserved		subclassv(2:0)			jesdv		
config73	0x49	0x0000	link_assign(15:0)															
config74	0x4A	0x001E	lane_ena(7:0)						jesd_test_seq(1:0)		dual	init_state(3:0)			jesd_reset_n			
config75	0x4B	0x0000	reserved			rbd_m1(4:0)				f_m1(7:0)								
config76	0x4C	0x0000	reserved			k_m1(4:0)				reserved	reserved	reserved	l_m1(4:0)					
config77	0x4D	0x0300	m_m1(7:0)						reserved						s_m1(4:0)			
config78	0x4E	0x0F0F	reserved			nprime_m1(4:0)				reserved	hd	scr	n_m1(4:0)					
config79	0x4F	0x1CC1	match_data(7:0)						match_specific	match_ctrl	no_lane_sync	reserved				jesd_commaalign_ena		
config80	0x50	0x0000	adjcnt_link0(3:0)			adjdir_link0	bid_link0(3:0)				cf_link0(4:0)				cs_link0(1:0)			
config81	0x51	0x00FF	did_link0(7:0)						sync_request_ena_link0(7:0)									
config82	0x52	0x00FF	reserved				disable_err_report_link0	phadj_link0	error_ena_link0(7:0)									
config83	0x53	0x0000	adjcnt_link1(3:0)			adjdir_link1	bid_link1(3:0)				cf_link1(4:0)				cs_link1(1:0)			
config84	0x54	0x00FF	did_link1(7:0)						sync_request_ena_link1(7:0)									
config85	0x55	0x00FF	reserved				disable_err_report_link1	phadj_link1	error_ena_link1(7:0)									
config86	0x56	0x0000	adjcnt_link2(3:0)			adjdir_link2	bid_link2(3:0)				cf_link2(4:0)				cs_link2(1:0)			
config87	0x57	0x00FF	did_link2(7:0)						sync_request_ena_link2(7:0)									
config88	0x58	0x00FF	reserved				disable_err_report_link2	phadj_link2	error_ena_link2(7:0)									
config89	0x59	0x0000	adjcnt_link3(3:0)			adjdir_link3	bid_link3(3:0)				cf_link3(4:0)				cs_link3(1:0)			
config90	0x5A	0x00FF	did_link3(7:0)						sync_request_ena_link3(7:0)									
config91	0x5B	0x00FF	reserved				disable_err_report_link3	phadj_link3	error_ena_link3(7:0)									
config92	0x5C	0x1111	err_cnt_clr_link3	sysref_mode_link3(2:0)			err_cnt_clr_link2	sysref_mode_link2(2:0)			err_cnt_clr_link1	sysref_mode_link1(2:0)		err_cnt_clr_link0	sysref_mode_link0(2:0)			
config93	0x5D	0x0000	reserved															
config94	0x5E	0x0000	res1(7:0)						res2(7:0)									
config95	0x60	0x0123	reserved	octetpath_sel(0)(2:0)			reserved	octetpath_sel(1)(2:0)			reserved	octetpath_sel(2)(2:0)		reserved	octetpath_sel(3)(2:0)			
config96	0x61	0x0456	reserved	octetpath_sel(4)(2:0)			reserved	octetpath_sel(5)(2:0)			reserved	octetpath_sel(6)(2:0)		reserved	octetpath_sel(7)(2:0)			

PRODUCT PREVIEW

Table 14. Register Map (continued)

Name	Address	Default	(MSB) Bit 15	Bit 14	Bit 13	Bit 12	Bit 11	Bit 10	Bit 9	Bit 8	Bit 7	Bit 6	Bit 5	Bit 4	Bit 3	Bit 2	Bit 1	(LSB) Bit 0
config97	0x62	0x000F	syncn_pol	reserved			syncncd_sel(3:0)			syncnab_sel(3:0)			syncn_sel(3:0)					
config98	0x63	0x0000	reserved	reserved			reserved			reserved								
config98	0x64	0x0000	reserved	reserved			reserved			reserved			Reserved					
config100	0x65	0x0000				alarm_l_error(0)(7:0)						reserved			alarm_fifo_flags(0)(3:0)			
config101	0x66	0x0000				alarm_l_error(1)(7:0)						reserved			alarm_fifo_flags(1)(3:0)			
config102	0x67	0x0000				alarm_l_error(2)(7:0)						reserved			alarm_fifo_flags(2)(3:0)			
config103	0x68	0x0000				alarm_l_error(3)(7:0)						reserved			alarm_fifo_flags(3)(3:0)			
config104	0x69	0x0000				alarm_l_error(4)(7:0)						reserved			alarm_fifo_flags(4)(3:0)			
config105	0x6A	0x0000				alarm_l_error(5)(7:0)						reserved			alarm_fifo_flags(5)(3:0)			
config106	0x6B	0x0000				alarm_l_error(6)(7:0)						reserved			alarm_fifo_flags(6)(3:0)			
config107	0x6C	0x0000				alarm_l_error(7)(7:0)						reserved			alarm_fifo_flags(7)(3:0)			
config108	0x6D	0x0000	alarm_sysref_err(3:0)						alarm_pap(3:0)			reserved			alarm_rw0_pll	alarm_rw1_pll	reserved	alarm_from_pll
config109	0x6E	0x00xx				alarm_from_shorttest(7:0)						memin_rw_losdct(7:0)						
config110	0x6F	0x0000	sfrac_coef0_ab(1;0)	sfrac_coef1_ab(4;0)						sfrac_coef2_ab(7;0)			Reserved					
config111	0x70	0x0000	reserved						sfrac_coef3_ab(9;0)									
config112	0x71	0x0000	sfrac_coef4_ab(15;0)															
config113	0x72	0x0000	sfrac_coef4_ab(18:16)	reserved						sfrac_coef5_ab(9;0)								
config114	0x73	0x0000	reserved						sfrac_coef6_ab(8;0)									
config115	0x74	0x0000	sfrac_coef7_ab(6;0)						sfrac_coef8_ab(4;0)			sfrac_coef9_ab(1;0)	Reserved					
config116	0x75	0x0000	sfrac_invgain_ab(15;0)															
config117	0x76	0x0000	sfrac_invgain_ab(19:16)			reserved						lfras_coefset_a(2;0)		lfras_coefset_b(2;0)				
config118	0x77	0x0000	sfrac_coef0_cd(1;0)	sfrac_coef1_cd(4;0)						sfrac_coef2_cd(7;0)			Reserved					
config119	0x78	0x0000	reserved						sfrac_coef3_cd(9;0)									
config120	0x79	0x0000	sfrac_coef4_cd(15;0)															
config121	0x7A	0x0000	sfrac_coef4_cd(18:16)	reserved						sfrac_coef5_cd(9;0)								
config122	0x7B	0x0000	reserved						sfrac_coef6_cd(8;0)									
config123	0x7C	0x0000	sfrac_coef7_cd(6;0)						sfrac_coef8_cd(4;0)			sfrac_coef9_cd(1;0)	Reserved					
config124	0x7D	0x0000	sfrac_invgain_cd(15;0)															
config125	0x7E	0x0000	sfrac_invgain_cd(19:16)			reserved						lfras_coefset_c(2;0)		lfras_coefset_d(2;0)				
config126	0x7F	0x0000	reserved			reserved			reserved			reserved						
config127	0x80	0x0000	memin_efc_autoload_done	memin_efc_error(4;0)			reserved			reserved			vendorid(1;0)		versionid(2;0)			

PRODUCT PREVIEW

REGISTER DESCRIPTIONS

REGISTER NAME: config0 – Address: 0x00, Default: 0x0218					
Register Name	Addr (Hex)	Bit	Name	Function	Default Value
config0	0x0	15	qmc_offsetab_ena	Enable the offset function for the AB data path when asserted.	0
		14	qmc_offsetcd_ena	Enable the offset function for the CD data path when asserted.	0
		13	qmc_corrab_ena	Enable the Quadrature Modulator Correction (QMC) function for the AB data path when asserted.	0
		12	qmc_corr_ena	Enable the QMC function for the CD data path when asserted.	0
		11:08	interp	Determines the interpolation amount. 0000: 1x 0001: 2x 0010: 4x 0100: 8x 1000: 16x	0010
		7	alarm_zeros_txenable_ena	When asserted any alarm that isn't masked will mid-level the DAC output.	0
		6	outsum_ena	Turns on the summing of the A+C and B+D data paths.	0
		5	alarm_zeros_jesd_data_ena	When asserted any alarm that isn't masked will zero the data coming out of the JESD block.	0
		4	alarm_out_ena	When asserted the pin ALARM becomes an output instead of a tri-stated pin.	1
		3	alarm_out_pol	This bit changes the polarity of the ALARM signal. (0=negative logic, 1=positive logic)	1
		2	pap_ena	Turns on the Power Amp Protection (PAP) logic.	0
		1	inv_sinc_ab_ena	Turns on the inverse sinc filter for the AB path when programmed to '1'.	0
		0	inv_sinc_cd_ena	Turns on the inverse sinc filter for the CD path when programmed to '1'.	0

REGISTER NAME: config1 – Address: 0x01, Default: 0x0003					
Register Name	Addr (Hex)	Bit	Name	Function	Default Value
config1	0x1	15	sfrac_ena_ab	Turn on the small fractional delay filter for the AB data path.	0
		14	sfrac_ena_cd	Turn on the small fractional delay filter for the CD data path.	0
		13	lfrac_ena_ab	Turn on the large fractional delay filter for the AB data path.	0
		12	lfrac_ena_cd	Turn on the large fractional delay filter for the CD data path.	0
		11	sfrac_sel_ab	Select which data path is delay through the filter and which is delayed through the matched delay line. 0 : Data path B goes through filter 1 : Data path A goes through filter	0
		10	sfrac_sel_cd	Select which data path is delay through the filter and which is delayed through the matched delay line. 0 : Data path D goes through filter 1 : Data path C goes through filter	0
		9	reserved	Reserved	0
		8	reserved	Reserved	0
		7	daca_compliment	When asserted the output to the DACA is complimented. This allows the user of the chip to effectively change the + and – designations of the IOUTA pins.	0
		6	dacb_compliment	When asserted the output to the DACB is complimented. This allows the user of the chip to effectively change the + and – designations of the IOUTB pins.	0
		5	dacc_compliment	When asserted the output to the DACC is complimented. This allows the user of the chip to effectively change the + and – designations of the IOUTC pins.	0
		4	dacd_compliment	When asserted the output to the DACD is complimented. This allows the user of the chip to effectively change the + and – designations of the IOUTD pins.	0
		3	reserved	Reserved	0
		2	reserved	Reserved	0
1	reserved	Reserved	1		
0	reserved	Reserved	1		

REGISTER NAME: config2 – Address: 0x02, Default: 0x2002					
Register Name	Addr (Hex)	Bit	Name	Function	Default Value
config2	0x2	10:14	dac_bitwidth	Determines the bit width of the DAC. 00 : 16 bits 01 : 14 bits 10 : 16 bits 11 : 12 bits	00
		13	zero_invalid_data	Zero the data from the JESD block when the link is not established.	1
		12	shorttest_ena	Turns on the short test pattern of the JESD interface.	0
		11	reserved	Reserved	0
		10	reserved	Reserved	0
		9	reserved	Reserved	0
		8	reserved	Reserved	0
		7	sif4_ena	When asserted the SIF interface becomes a 4 pin interface. This bit has a lower priority than the dieid_ena bit.	0
		6	mixer_ena	When set high, the mixer block is turned on.	0
		5	mixer_gain	Add 6dB of gain to the mixer output when asserted.	0
		4	nco_ena	When set high, the full NCO block is turned on. This is not necessary for the fs/2, fs/4, -fs/4 and fs/8 modes.	0
		3	reserved	Reserved	0
		2	reserved	Reserved	0
		1	twos	When asserted, this bit tells the chip to presume that 2's complement data is arriving at the input. Otherwise offset binary is presumed.	1
0	sif_reset	A transition from 0->1 causes a reset of the SIF registers. This bit is self clearing.	0		

REGISTER NAME: config3 – Address: 0x03, Default: 0xF380					
Register Name	Addr (Hex)	Bit	Name	Function	Default Value
config3	0x3	15:12	coarse_dac	Scales the output current in 16 equal steps. $\frac{V_{refIO}}{R_{bias}} \times 4 \times (\text{mem_coarse_daca} + 1)$	1111
		11:8	reserved	Reserved	0011
		7	fifo_error_zeros_data_ena	When asserted SerDes FIFO errors zero the data out of the JESD block.	1
		6:1	reserved	Reserved	000000
		0	sif_txenable	When asserted the internal value of TXENABLE is '1'.	0

PRODUCT PREVIEW

REGISTER NAME: config4 – Address: 0x04, Default: 0x00FF					
Register Name	Addr (Hex)	Bit	Name	Function	Default Value
config4	0x4	15:0	alarms_maxk(15:0)	Each bit is used to mask an alarm. Assertion masks the alarm: bit15 = mask lane7 lane errors bit14 = mask lane6 lane errors bit13 = mask lane5 lane errors bit12 = mask lane4 lane errors bit11 = mask lane3 lane errors bit10 = mask lane2 lane errors bit9 = mask lane1 lane errors bit8 = mask lane0 lane errors bit7 = mask lane7 FIFO flags bit6 = mask lane6 FIFO flags bit5 = mask lane5 FIFO flags bit4 = mask lane4 FIFO flags bit3 = mask lane3 FIFO flags bit2 = mask lane2 FIFO flags bit1 = mask lane1 FIFO flags bit0 = mask lane0 FIFO flags	0x00FF

REGISTER NAME: config5 – Address: 0x05, Default: 0xFFFF					
Register Name	Addr (Hex)	Bit	Name	Function	Default Value
config5	0x5	15:0	alarms_mask(31:16)	Each bit is used to mask an alarm. Assertion masks the alarm: bit15 = mask SYSREF errors on link3 bit14 = mask SYSREF errors on link2 bit13 = mask SYSREF errors on link1 bit12 = mask SYSREF errors on link0 bit11 = mask alarm from PAP A block bit10 = mask alarm from PAP B block bit9 = mask alarm from PAP C block bit8 = mask alarm from PAP D block bit7 = reserved bit6 = reserved bit5 = reserved bit4 = reserved bit3 = mask alarm from SerDes block 0 PLL lock bit2 = mask alarm from SerDes block 1 PLL lock bit1 = mask SYSREF setup/hold measurement alarm bit0 = mask DAC PLL lock alarm	0xFFFF

REGISTER NAME: config6 – Address: 0x06, Default: 0xFFFF					
Register Name	Addr (Hex)	Bit	Name	Function	Default Value
config6	0x6	15:0	alarms_mask(47:32)	Each bit is used to mask an alarm. Assertion masks the alarm: bit15 = mask alarm from lane7 short test bit14 = mask alarm from lane6 short test bit13 = mask alarm from lane5 short test bit12 = mask alarm from lane4 short test bit11 = mask alarm from lane3 short test bit10 = mask alarm from lane2 short test bit9 = mask alarm from lane1 short test bit8 = mask alarm from lane0 short test bit7 = mask alarm from lane7 loss of signal detect bit6 = mask alarm from lane6 loss of signal detect bit5 = mask alarm from lane5 loss of signal detect bit4 = mask alarm from lane4 loss of signal detect bit3 = mask alarm from lane3 loss of signal detect bit2 = mask alarm from lane2 loss of signal detect bit1 = mask alarm from lane1 loss of signal detect bit0 = mask alarm from lane0 loss of signal detect	0xFFFF

REGISTER NAME: config7 – Address: 0x07, Default: 0x0000					
Register Name	Addr (Hex)	Bit	Name	Function	Default Value
config7 No RESET Value	0x7	15:8	memin_tempdata	This is the output from the chip temperature sensor. NOTE: when reading these bits the SIF interface must be extremely slow, 1MHz range.	0x00
		7:5	reserved	Reserved	000
		4:0	memin_lane_skew	Measure of the lane skew for link0 only. Updated when the RBD is released and measured in terms of JESD clock. NOTE: these bits are READ_ONLY	0000

REGISTER NAME: config8 – Address: 0x08, Default: 0x0000					
Register Name	Addr (Hex)	Bit	Name	Function	Default Value
config8 AUTO SYNC	0x8	15	reserved	Reserved	0
		14	reserved	Reserved	0
		13	reserved	Reserved	0
		12:0	qmc_offseta	The DAC A offset correction. The offset is measured in DAC LSBs. NOTE: Writing this register causes an auto-sync to be generated in the QMC OFFSET block.	0x0000

REGISTER NAME: config9 – Address: 0x09, Default: 0x0000					
Register Name	Addr (Hex)	Bit	Name	Function	Default Value
config9	0x9	15:13	reserved	Reserved	000
		12:0	qmc_offsetb	The DAC B offset correction. The offset is measured in DAC LSBs.	0x0000

REGISTER NAME: config10 – Address: 0x0A, Default: 0x0000					
Register Name	Addr (Hex)	Bit	Name	Function	Default Value
config10 AUTO SYNC	0xA	15:13	reserved	Reserved	000
		12:0	qmc_offsetc	The DAC C offset correction. The offset is measured in DAC LSBs. NOTE: Writing this register causes an auto-sync to be generated in the QMC OFFSET block.	0x0000

REGISTER NAME: config11 – Address: 0x0B, Default: 0x0000					
Register Name	Addr (Hex)	Bit	Name	Function	Default Value
config11	0xB	15:13	reserved	Reserved	000
		12:0	qmc_offsetd	The DAC D offset correction. The offset is measured in DAC LSBs	0x0000

REGISTER NAME: config12 – Address: 0xC, Default: 0x0400					
Register Name	Addr (Hex)	Bit	Name	Function	Default Value
config12	0xC	15	reserved	Reserved	0
		14	reserved	Reserved	0
		13	reserved	Reserved	0
		12	reserved	Reserved	0
		11	reserved	Reserved	0
		10:0	gmc_gaina	The quadrature correction gain A for DACAB path. The decimal point for the multiplication is just left of bit9. This word is treated as unsigned so the range is 0 to 1.9990. LSB=0.0009766	0x400

REGISTER NAME: config13 – Address: 0xD, Default: 0x0400					
Register Name	Addr (Hex)	Bit	Name	Function	Default Value
config13	0xD	15	fs8	These bits turn on the different coarse mixing options. Combining the different options together can result in every possible n*Fs/8 [n=0->7]. Below is the valid programming table: cmix=(fs8, fs4, fs2, fsm4) 0000 : no mixing 0001 : -fs/4 0010 : fs/2 0100 : fs/4 1000 : fs/8 1100 : 3fs/8 1010 : 5fs/8 1110 : 7fs/8	0
		14	fs4		0
		13	fs2		0
		12	fsm4		0
		11	reserved	Reserved	0
		10:0	qmc_gainb	The quadrature correction gain B for DAC AB path. The decimal point for the multiplication is just left of bit9. This word is treated as unsigned so the range is 0 to 1.9990. LSB=0.0009766.	0x400

REGISTER NAME: config14 – Address: 0x0E, Default: 0x0400					
Register Name	Addr (Hex)	Bit	Name	Function	Default Value
config14	0xE	15	reserved	Reserved	0
		14	reserved	Reserved	0
		13	reserved	Reserved	0
		12	reserved	Reserved	0
		11	reserved	Reserved	0
		10:0	gmc_gainc	The quadrature correction gain A for DACCD path. The decimal point for the multiplication is just left of bit9. This word is treated as unsigned so the range is 0 to 1.9990. LSB=0.0009766.	0x400

REGISTER NAME: config15 – Address: 0x0F, Default: 0x0400					
Register Name	Addr (Hex)	Bit	Name	Function	Default Value
config15	0xF	15:14	output_delayab	Delays the output to the DACs from 0 to 3 DAC clock cycles.	00
		13:12	output_delaycd	Delays the output to the DACs from 0 to 3 DAC clock cycles.	00
		11	reserved	Reserved	0
		10:0	qmc_gaind	The quadrature correction gain B for DACCD path. The decimal point for the multiplication is just left of bit9. This word is treated as unsigned so the range is 0 to 1.9990. LSB=0.0009766.	0x400

REGISTER NAME: config16 – Address: 0x10, Default: 0x0000					
Register Name	Addr (Hex)	Bit	Name	Function	Default Value
config16 AUTO SYNC	0x10	15	reserved	Reserved	0
		14	reserved	Reserved	0
		13	reserved	Reserved	0
		12	reserved	Reserved	0
		11:0	qmc_phaseab	The QMC correction phase term for the DACAB path. The range is –0.5 to 0.49975. Programming “100000000000” = –0.5. Programming “011111111111” = 0.49975.	0x000

REGISTER NAME: config17 – Address: 0x11, Default: 0x0000					
Register Name	Addr (Hex)	Bit	Name	Function	Default Value
config17 AUTO SYNC	0x11	15	reserved	Reserved	0
		14	reserved	Reserved	0
		13	reserved	Reserved	0
		12	reserved	Reserved	0
		11:0	qmc_phaseacd	The QMC correction phase term for the DACAD path. The range is –0.5 to 0.49975. Programming “100000000000” = –0.5. Programming “011111111111” = 0.49975.	0x000

REGISTER NAME: config18 – Address: 0x12, Default: 0x0000					
Register Name	Addr (Hex)	Bit	Name	Function	Default Value
config18 AUTO SYNC	0x12	15:0	phaseoffsetab	Phase offset for NCO in DACAB path	0x0000

REGISTER NAME: config19 – Address: 0x13, Default: 0x0000					
Register Name	Addr (Hex)	Bit	Name	Function	Default Value
config19 AUTO SYNC	0x13	15:0	phaseoffsetcd	Phase offset for NCO in DACAB path	0x0000

REGISTER NAME: config20 – Address: 0x14, Default: 0x0000					
Register Name	Addr (Hex)	Bit	Name	Function	Default Value
config20	0x14	15:0	phaseaddab	Lower 16 bits of NCO Frequency adjust word for DACAB path.	0x0000

REGISTER NAME: config21 – Address: 0x15, Default: 0x0000					
Register Name	Addr (Hex)	Bit	Name	Function	Default Value
config21	0x15	15:0	phaseaddab	Middle 16 bits of NCO Frequency adjust word for DACAB path.	0x0000

REGISTER NAME: config22 – Address: 0x16, Default: 0x0000					
Register Name	Addr (Hex)	Bit	Name	Function	Default Value
config22	0x16	15:0	phaseaddab	Upper 16 bits of NCO Frequency adjust word for DACAB path.	0x0000

REGISTER NAME: config23 – Address: 0x17, Default: 0x0000					
Register Name	Addr (Hex)	Bit	Name	Function	Default Value
config23	0x17	15:0	phaseaddcd	Lower 16 bits of NCO Frequency adjust word for DACCD path.	0x0000

REGISTER NAME: config24 – Address: 0x18, Default: 0x0000					
Register Name	Addr (Hex)	Bit	Name	Function	Default Value
config24	0x18	15:0	phaseaddcd	Middle 16 bits of NCO Frequency adjust word for DACCD path.	0x0000

REGISTER NAME: config25 – Address: 0x19, Default: 0x0000					
Register Name	Addr (Hex)	Bit	Name	Function	Default Value
config25	0x19	15:0	phaseaddcd	Upper 16 bits of NCO Frequency adjust word for DACCD path.	0x0000

REGISTER NAME: config26 – Address: 0x1A, Default: 0x0020					
Register Name	Addr (Hex)	Bit	Name	Function	Default Value
config26	0x1A	15:10	reserved	Reserved	000000
		9	reserved	Reserved	0
		8	vbgr_sleep	Turns off the Bandgap over internal R bias current generator bias	0
		7	biasopamp_sleep	Turns off the bias OP amp when high.	0
		6	tsense_sleep	Turns off the temperature sensor when asserted.	0
		5	pll_sleep	Puts the DAC PLL into sleep mode when asserted.	1 FUSE controlled
		4	clkrecv_sleep	When asserted the clock input receiver gets put into sleep mode. This also affects the SYSREF receiver as well.	0
		3	daca_sleep	When asserted DACA is put into sleep mode	0
		2	dacb_sleep	When asserted DACB is put into sleep mode	0
		1	dacc_sleep	When asserted DACC is put into sleep mode	0
0	dacd_sleep	When asserted DACD is put into sleep mode	0		

REGISTER NAME: config27 – Address: 0x1B, Default: 0x0000					
Register Name	Addr (Hex)	Bit	Name	Function	Default Value
config27	0x1B	15	extref_ena	Allows the chip to use an external reference or the internal reference. (0=internal, 1=external)	0
		14:12	dtest_lane	Selects the lane to output the test signal. 0=lane0, 7=lane7	000
		11:8	dtest	Allows digital test signals to come out the ALARM pin. 0000 : Test disabled, normal ALARM pin function 0001 : SERDES Block0 PLL clock/80 0010 : SERDES Block1 PLL clock/80 0011 : TESTFAIL (lane selected by dtest_lane) 0100 : SYNC(lane selected by dtest_lane) 0101 : OCIP (lane selected by dtest_lane) 0110 : EQUUNDER (lane selected by dtest_lane) 0111 : EQOVER (lane selected by dtest_lane) 1000 – 1111 : not used	0000
		7	reserved	Reserved	0
		6	reserved	Reserved	0
		5:0	atest	Selects measurement of various internal signals at the ATEST pin. 0=off 000001 : DAC PLL VSSA (0V) 000010 : DAC PLL VDD at DACCLK receiver and ndivider (0.9V) 000011 : DAC PLL 100uA bias current measurement into 0V 000100 : DAC PLL 100uA vbias at VCO (~-0.8V nmos diode) 000101 : DAC PLL VDD at prescaler and mdivider (0.9V) 000110 : DAC PLL VSSA (0V) 000111 : DAC PLL VDDA1.8 (1.8V) 001000 : DAC PLL loop filter voltage (0 to 1V, -0.5V when locked) 001001 : DACA VDDA18 (1.8V) 001010 : DACA VDDCLK (0.9) 001011 : DACA VDDDAC (0.9) 001100 : DACA VSSA (0V) 001101 : DACA VSSESD (0V) 001110 : DACA VSSA (0V) 001111 : DACA main current source PMOS cascode bias (1.65V) 010000 : DACA output switch cascode bias (0.4V) 010001 : DACB VDDA18 (1.8V) 010010 : DACB VDDCLK (0.9) 010011 : DACB VDDDAC (0.9) 010100 : DACB VSSA (0V) 010101 : DACB VSSESD (0V) 010110 : DACB VSSA (0V) 010111 : DACB main current source PMOS cascode bias (1.65V) 011000 : DACB output switch cascode bias (0.4V) 011001 : DACC VDDA18 (1.8V) 011010 : DACC VDDCLK (0.9) 011011 : DACC VDDDAC (0.9) 011100 : DACC VSSA (0V) 011101 : DACC VSSESD (0V) 011110 : DACC VSSA (0V) 011111 : DACC main current source PMOS cascode bias (1.65V)	000000

PRODUCT PREVIEW

REGISTER NAME: config27 – Address: 0x1B, Default: 0x0000					
Register Name	Addr (Hex)	Bit	Name	Function	Default Value
config27 (continued)	0x1B	5:0	atest	100000 : DACC output switch cascode bias (0.4V) 100001 : DACD VDDA18 (1.8V) 100010 : DACD VDDCLK (0.9) 100011 : DACD VDDDAC (0.9) 100100 : DACD VSSA (0V) 100101 : DACD VSSES (0V) 100110 : DACD VSSA (0V) 100111 : DACD main current source PMOS cascode bias (1.65V) 101000 : DACD output switch cascode bias (0.4V) 101001 : Temp Sensor VSSA (0V) 101010 : Temp Sensor amplifier output (0 to 1.8V) 101011 : Temp Sensor reference output (-0.6V, can be trimmed) 101100 : Temp Sensor comparator output (0 to 1.8V) 101101 : Temp Sensor 64uA bias voltage (-0.8V nmos diode) 101110 : BIASGEN 100uA bias measured to 0V (to be trimmed) 101111 : Temp Sensor VDD (0.9V) 110000 : Temp Sensor VDDA18 (1.8V) 110001 : DAC bias current measured into 1.8V. scales with coarse DAC setting (7.3µA to 117µA) 110010 : Bangap PTAT current measured into 0V (~20µA) 110011 : CoarseDAC PMOS current source gate (-1V) 110100 : RBIAS (0.9V) 110101 : EXTIO (0.9V) 110110 : Bandgap PMOS cascode gate (0.7V) 110111 : Bandgap startup circuit output (-0V when BG started) 111000 : Bandgap output (0.9V, can be trimmed) 111001 : SYNCB LVDS buffer reference voltage (1.2V) must set syncb_lvds_efuse_sel to measure. 111010 : VSS in digital core MET1 (0V) 111011 : VSS in digital core MET1 (0V) 111100 : VSS near bump (0V) 111101 : VDDDIG in digital core MET1 (0.9V) 111110 : VDDDIG in digital core MET1 (0.9V)	000000

REGISTER NAME: config28 – Address: 0x1, Default: 0x0000					
Register Name	Addr (Hex)	Bit	Name	Function	Default Value
config28	0x1C	15:8	reserved	reserved	0x00
		7:0	reserved	reserved	0x00

REGISTER NAME: config29 – Address: 0x1D, Default: 0x0000					
Register Name	Addr (Hex)	Bit	Name	Function	Default Value
config29	0x1D	15:8	reserved	reserved	0x00
		7:0	reserved	reserved	0x00

REGISTER NAME: config30 – Address: 0x1E, Default: 0x1111					
Register Name	Addr (Hex)	Bit	Name	Function	Default Value
config30	0x1E	15:12	syncsel_ qmoffsetab	Select the sync for the QMCOffsetAB block. A '1' in the selected bit place allows the selected sync to pass to the block. bit0 = auto-sync from SIF register write bit1 = sysref bit2 = sync_out from JESD bit3 = sif_sync	0x1
		11:8	syncsel_ qmoffsetcd	Select the sync for the QMCOffsetCD block. A '1' in the selected bit place allows the selected sync to pass to the block. bit0 = auto-sync from SIF register write bit1 = sysref bit2 = sync_out from JESD bit3 = sif_sync	0x1
		7:4	syncsel_ qmcorrab	Select the sync for the QMCCorrAB block. A '1' in the selected bit place allows the selected sync to pass to the block. bit0 = auto-sync from SIF register write bit1 = sysref bit2 = sync_out from JESD bit3 = sif_sync	0x1
		3:0	syncsel_ qmcorrcd	Select the sync for the QMCCorrCD block. A '1' in the selected bit place allows the selected sync to pass to the block. bit0 = auto-sync from SIF register write bit1 = sysref bit2 = sync_out from JESD bit3 = sif_sync	0x1

REGISTER NAME: config31 – Address: 0x1F, Default: 0x1111					
Register Name	Addr (Hex)	Bit	Name	Function	Default Value
config31	0x1F	15:12	syncsel_ mixerab	Select the sync for the mixerAB block. A '1' in the selected bit place allows the selected sync to pass to the block. bit0 = auto-sync from SIF register write bit1 = sysref bit2 = sync_out from JESD bit3 = sif_sync	0x1
		11:8	syncsel_ mixercd	Select the sync for the mixerCD block. A '1' in the selected bit place allows the selected sync to pass to the block. bit0 = auto-sync from SIF register write bit1 = sysref bit2 = sync_out from JESD bit3 = sif_sync	0x1
		7:4	syncsel_ nco	Select the sync for the NCO accumulators. A '1' in the selected bit place allows the selected sync to pass to the block. bit0 = '0' bit1 = sysref bit2 = sync_out from JESD bit3 = sif_sync	0x4
		3:2	reserved	Reserved	00
		1	sif_sync	This is the SIF SYNC signal.	0
		0	reserved	Reserved	0

REGISTER NAME: config32 – Address: 0x20, Default: 0x0000					
Register Name	Addr (Hex)	Bit	Name	Function	Default Value
config32	0x20	15:12	syncsel_dither	Select the sync for the Dithering block. bit0 = '0' bit1 = sysref bit2 = sync_out from JESD bit3 = sif_sync	0x0
		11:8	reserved	Reserved	0x0
		7:4	syncsel_pap	7:4 Select the sync for the PA Protection block. bit0 = '0' bit1 = sysref bit2 = sync_out from JESD bit3 = sif_sync 0x0	0x0
		3:0	syncsel_fir5a	Select the sync for the small fractional delay FIR filter coefficient loading. bit0 = '0' bit1 = sysref bit2 = sync_out from JESD bit3 = sif_sync	0x0

REGISTER NAME: config33 – Address: 0x21, Default: 0x0000					
Register Name	Addr (Hex)	Bit	Name	Function	Default Value
config33	0x21	15:0	reserved	Reserved	0x0000

REGISTER NAME: config34 – Address: 0x22, Default: 0x1B1B					
Register Name	Addr (Hex)	Bit	Name	Function	Default Value
config34	0x22	15:14	patha_in_sel	This selects the word used for the path A input. 00 = Sample 0 from JESD is selected for data path A 01 = Sample 1 from JESD is selected for data path A 10 = Sample 2 from JESD is selected for data path A 11 = Sample 3 from JESD is selected for data path A	00
		13:12	pathb_in_sel	This selects the word used for the path B input. 00 = Sample 0 from JESD is selected for data path B 01 = Sample 1 from JESD is selected for data path B 10 = Sample 2 from JESD is selected for data path B 11 = Sample 3 from JESD is selected for data path B	01
		11:10	pathc_in_sel	This selects the word used for the path C input. 00 = Sample 0 from JESD is selected for data path C 01 = Sample 1 from JESD is selected for data path C 10 = Sample 2 from JESD is selected for data path C 11 = Sample 3 from JESD is selected for data path C	10
		9:8	pathd_in_sel	This selects the word used for the path D input. 00 = Sample 0 from JESD is selected for data path D 01 = Sample 1 from JESD is selected for data path D 10 = Sample 2 from JESD is selected for data path D 11 = Sample 3 from JESD is selected for data path D	11
		7:6	patha_out_sel	This selects the word used for the DACA output. 00 = data path A goes to DACA 01 = data path B goes to DACA 10 = data path C goes to DACA 11 = data path D goes to DACA	00
		5:4	pathb_out_sel	This selects the word used for the DACB output. 00 = data path A goes to DACB 01 = data path B goes to DACB 10 = data path C goes to DACB 11 = data path D goes to DACB	01
		3:2	pathc_out_sel	This selects the word used for the DACC output. 00 = data path A goes to DACC 01 = data path B goes to DACC 10 = data path C goes to DACC 11 = data path D goes to DACC	10
		1:0	pathd_out_sel	This selects the word used for the DACD output. 00 = data path A goes to DACD 01 = data path B goes to DACD 10 = data path C goes to DACD 11 = data path D goes to DACD	11

PRODUCT PREVIEW

REGISTER NAME: config35 – Address: 0x23, Default: 0xFFFF					
Register Name	Addr (Hex)	Bit	Name	Function	Default Value
config35	0x23	15:0	sleep_cntl	This controls the routing of the SLEEP pin signal to different blocks. Assertion means that the SLEEP signal will be sent to the block. These bits do not override the SIF bits, just the SLEEP signal from the pin. When asserted, bit15 through bit9 = Not used bit8 = Allows the Band gap over R to sleep (BUG... in this PG it is hooked to bit7) bit7 = Allows the Bias OP Amp to sleep bit6 = Allows the TEMP Sensor to sleep bit5 = Allows the PLL to sleep bit4 = Allows the CLK_RECV to sleep bit3 = Allows DACD to sleep bit2 = Allows DACC to sleep bit1 = Allows DACB to sleep bit0 = Allows DACA to sleep	0xFFFF

REGISTER NAME: config36 – Address: 0x24, Default: 0x0000					
Register Name	Addr (Hex)	Bit	Name	Function	Default Value
config36	0x24	15:13	reserved	Reserved	000
		12:7	reserved	Reserved	000000
		6:4	cdvrser_sysref_mode	Determines how SYSREF is used to sync the clock dividers in the device. 000 = Don't use SYSREF pulse 001 = Use all SYSREF pulses 010 = Use only the next SYSREF pulse 011 = Skip one SYSREF pulse then use only the next one 100 = Skip one SYSREF pulse then use all pulses.	000
		3:2	reserved	Reserved	00
		1:0	reserved	Reserved	00

REGISTER NAME: config37 – Address: 0x25, Default: 0x8000					
Register Name	Addr (Hex)	Bit	Name	Function	Default Value
config37	0x25	15:13	clkjesd_div	This controls the amount of dividing down the DACCLK gets to generate the JESD clock. It is independent of the interpolation because of the different JESD interfaces. "000" : DACCLK "001" : div2 "010" : div4 "011" : div8 "100" : div16 "101" : div32 "110" : always 1 "111" : always 0	100
		12:10	reserved	Reserved	000
		9:7	reserved	Reserved	000
		6:4	reserved	Reserved	000
		3:1	reserved	Reserved	000
		0	reserved	Reserved	0

REGISTER NAME: config38 – Address: 0x26, Default: 0x0000					
Register Name	Addr (Hex)	Bit	Name	Function	Default Value
config38	0x26	15:12	dither_ena	Turns on DITHER block for each data path bit15 = data path D bit14 = data path C bit13 = data path B bit12 = data path A	0000
		11:8	dither_mixer_ena	Turns on the FS/2 mixer at the output of the CIC in the DITHER block. bit11 = data path D bit10 = data path C bit9 = data path B bit8 = data path A	0000
		7:4	dither_sra_sel	Select the amount of dithering added to the signal. 0 is the maximum dithering.	0000
		3:2	reserved	Reserved	00
		1	reserved	Reserved	0
		0	reserved	Reserved	0

REGISTER NAME: config39 – Address: 0x27, Default: 0x0000					
Register Name	Addr (Hex)	Bit	Name	Function	Default Value
config39	0x27	15:0	reserved	Reserved	0x0000

REGISTER NAME: config40 – Address: 0x28, Default: 0x0000					
Register Name	Addr (Hex)	Bit	Name	Function	Default Value
config40 WRITE TO CLEAR	0x28	15:0	reserved	Reserved	0x0000

REGISTER NAME: config41 – Address: 0x29, Default: 0x0000					
Register Name	Addr (Hex)	Bit	Name	Function	Default Value
config41	0x29	15:0	reserved	Reserved	0xFFFF

REGISTER NAME: config42 – Address: 0x2A, Default: 0x0000					
Register Name	Addr (Hex)	Bit	Name	Function	Default Value
config42	0x2A	15:0	reserved	Reserved	0000

REGISTER NAME: config43 – Address: 0x2B, Default: 0x0000					
Register Name	Addr (Hex)	Bit	Name	Function	Default Value
config43	0x2B	15:0	reserved	Reserved	0x0000

REGISTER NAME: config44 – Address: 0x2C, Default: 0x0000					
Register Name	Addr (Hex)	Bit	Name	Function	Default Value
config44	0x2C	15:0	reserved	Reserved	0000

REGISTER NAME: config45 – Address: 0x2D, Default: 0x0000					
Register Name	Addr (Hex)	Bit	Name	Function	Default Value
config45	0x2D	15	reserved	Reserved	0
		14:4	reserved	Reserved	0000000000
		3	pap_dlylen_sel	Select the length of the PAP average: 0 : 64 samples 1 : 128 samples	0
		2:0	pap_gain	The amount of attenuation to apply when the threshold for PAP is met: 000 : no attenuation 001 : divide by 2 010 : divided by 4 011 : divided by 8 100 : divided by 16 101 : no attenuation 110 : no attenuation 111 : no attenuation	000

REGISTER NAME: config46 – Address: 0x2E, Default: 0xFFFF					
Register Name	Addr (Hex)	Bit	Name	Function	Default Value
config46	0x2E	15:0	pap_vth	The threshold value for the PA protection logic. When the power measurement is greater than this activate the PA protection logic.	0xFFFF

REGISTER NAME: config47 – Address: 0x2F, Default: 0x0004					
Register Name	Addr (Hex)	Bit	Name	Function	Default Value
config47	0x2F	15	reserved	Reserved	0
		14	titest_dieid_read_ena	When asserted, the die ID can be read out after fuse autoload is finished on register 100-107. When de-asserted normal function of the registers is read out.	0
		13	reserved	Reserved	0
		12:3	reserved	Reserved	0000000000
		2	reserved	Reserved	1
		1	reserved	Reserved	0
		0	sifdac_ena	When asserted the DAC output is set to the value in register sifdac.	0

REGISTER NAME: config48 – Address: 0x30, Default: 0x0000					
Register Name	Addr (Hex)	Bit	Name	Function	Default Value
config48	0x30	15:0	sifdc	This is the value that is sent to the digital blocks when register sifdac_ena is asserted.	0x0000

REGISTER NAME: config49 – Address: 0x31, Default: 0x0000					
Register Name	Addr (Hex)	Bit	Name	Function	Default Value
config49	0x31	15:13	lockdet_adj	Adjusts the sensitivity of the DAC PLL lock detector; 4 settings from 000 to 011. The 011 setting has the widest lock detection window, tolerating more jitter while reporting a lock. The 000 setting has a narrow window and will indicate an unlocked state more often.	000
		12	pll_reset	When set, the M divider, N divider and PFD are held reset.	0
		11	pll_ndivsync_ena	When on, the SYSREF input is used to sync the N dividers of the PLL.	0
		10	pll_ena	Enables the PLL output as the DAC clock when set; the clock provided at the DACCLKP/N is used as the PLL reference clock. When cleared, the PLL is bypassed and the clock provided at the DACCLKP/N pins is used as the DAC clock	0 FUSE controlle d
		9:8	pll_cp	Must be set to 00 for proper PLL operation	00
		7:3	pll_n	Reference clock divider; divide by is N+1	00000
		2:0	memin_pll_lfvolt	Indicates the loop filter voltage; 111 is max, 000 is min. When the PLL is correctly programmed, this will read 011 or 100 for a centered loop filter voltage.	000 READ ONLY

REGISTER NAME: config50 – Address: 0x32, Default: 0x0000					
Register Name	Addr (Hex)	Bit	Name	Function	Default Value
config50	0x32	15:8	PLL_M	VCO feedback divider; divide by is M+1	00000000
		7:4	PLL_P	VCO prescaler divider; 0000 : div by 2 0001 : div by 3 0010 : div by 4 0011 : div by 5 0100 : div by 6 0101 : div by 7 0110 : div by 8 0111 : div by 9 1000 : div by 4 1001 : div by 6 1010 : div by 8 1011 : div by 10 1100 : div by 12	0000
		3:0	reserved	Reserved	0000

REGISTER NAME: config51 – Address: 0x33, Default: 0x100					
Register Name	Addr (Hex)	Bit	Name	Function	Default Value
config51	0x33	15	pll_vcose1	4GHz VCO selected when set, 5GHz VCO selected when cleared.	0
		14:9	pll_vco	VCO frequency range control; 000000 is fmin, 11111 is fmax	000000
		8:7	pll_vcoitune	VCO core bias current adjustment; 00 is 7mA, 01 is 8.4mA, 10 is 9.8mA, 11 is 11.2mA.	10
		6:2	pll_cp_adj	adjusts the charge pump current; 0 to 1.55mA is 50µA steps. Setting to 00000 will hold the LPF pin at 0V.	00000
		1:0	reserved	Reserved	00

PRODUCT PREVIEW

REGISTER NAME: config52 – Address: 0x34, Default: 0x0000					
Register Name	Addr (Hex)	Bit	Name	Function	Default Value
config52	0x34	15	syncb_lvds_lopwrb	SYNCB LVDS Output current control LSB; allows output current to be scaled from ~2mA to ~4mA	0
		14	syncb_lvds_lopwra	SYNCB LVDS Output current control MSB; allows output current to be scaled from ~2mA to ~4mA	0
		13	syncb_lvds_lpsel	SYNCB LVDS output on chip termination control; 100 Ω when cleared, 200 Ω when set.	0
		12	syncb_lvds_effuse_sel	Enabled SYNCB LVDS bias bandgap reference voltage to the ATEST multiplexer. ATEST must be set to 111001 to enable this output.	0
		11:10	reserved	Reserved	00
		9	reserved	Reserved	0
		8	syncb_lvds_sleep	The SYNCB LVDS output is in power down when set, active when cleared.	0
		7	syncb_lvds_sub_ena	SYNCB LVDS output common mode is 1.2V when cleared, 0.9V when set.	0
	6:0	reserved	Reserved	0000000	

REGISTER NAME: config53 – Address: 0x35, Default: 0x0000					
Register Name	Addr (Hex)	Bit	Name	Function	Default Value
config53	0x35	15:12	reserved	Reserved	0000
		11:8	reserved	Reserved	0000
		7:2	reserved	Reserved	000000
		1:0	reserved	Reserved	00

REGISTER NAME: config54 – Address: 0x36, Default: 0x0000					
Register Name	Addr (Hex)	Bit	Name	Function	Default Value
config54	0x36	15:0	reserved	Reserved	0x0000

REGISTER NAME: config55 – Address: 0x37, Default: 0x0000					
Register Name	Addr (Hex)	Bit	Name	Function	Default Value
config55	0x37	15:0	reserved	Reserved	0x0000

REGISTER NAME: config56 – Address: 0x38, Default: 0x0000					
Register Name	Addr (Hex)	Bit	Name	Function	Default Value
config56	0x38	15:0	reserved	Reserved	0x0000

REGISTER NAME: config57 – Address: 0x39, Default: 0x0000					
Register Name	Addr (Hex)	Bit	Name	Function	Default Value
config57	0x39	15:0	reserved	Reserved	0x0000

REGISTER NAME: config58 – Address: 0x3A, Default: 0x0000					
Register Name	Addr (Hex)	Bit	Name	Function	Default Value
config58	0x3A	15:0	reserved	Reserved	0x0000

REGISTER NAME: config59 – Address: 0x3B, Default: 0x0000					
Register Name	Addr (Hex)	Bit	Name	Function	Default Value
config59	0x3B	15	serdes_clk_sel	Select either the DAC PLL output or the DACCLK from the pins to be the SerDes PLL reference divider input clock.	0
		14:11	serdes_refclk_div	The divide amount for the serdes PLL reference clock divider. The divider amount is serdes_refclk_div plus one.	0000
		10:2	reserved	Reserved	000000000
		1:0	reserved	Reserved	00

REGISTER NAME: config60 – Address: 0x3C, Default: 0x0000					
Register Name	Addr (Hex)	Bit	Name	Function	Default Value
config60	0x3C	15:0	rw_cfgpll	Control the PLL of the SerDes. Bit15 – ENDIVCLK, enables output of a divide-by-5 of PLL clock. Bit14:13 – reserved. Bit12:11 – LB, specify loop bandwidth settings. Bit10 – SLEEPPLL, puts the PLL into sleep state when high. Bit9 – VRANGE, select between high and low VCO. Bit8:1 – MPY, select PLL multiply factor between 4 and 25. Bit0 – reserved.	0x0000

REGISTER NAME: config61 – Address: 0x3D, Default: 0x0000					
Register Name	Addr (Hex)	Bit	Name	Function	Default Value
config61	0x3D	15	reserved	Reserved	0
		14:0	rw_cfggrx0	Upper 15 bits of the configuration info for SerDes receivers. Bit14:12 – TESTPATT, Enables and selects verification of one of three PRBS patterns, a user defined pattern or a clock test pattern. Bit11 – reserved Bit10 – reserved Bit9:8 – reserved. Bit7 – reserved Bit6 – ENOC, enable samplers offset compensation. Bit5:3 – EQHLD, hold the equalizer in its current status. Bit2:0 – EQ, enable and configure the equalizer to compensate the loss in the transmission media. – CDR, configure the clock/data recovery algorithm.	0000000000000000

REGISTER NAME: config62 – Address: 0x3E, Default: 0x0000					
Register Name	Addr (Hex)	Bit	Name	Function	Default Value
config62	0x3E	15:0	rw_cfggrx0	Lower 16 bits of the configuration info for SerDes receivers. Bit15:13 – LOS, enable loss of signal detection. Bit12:11 – reserved. Bit10:8 – TERM, select input termination options for serial lanes. Note: AC coupling is recommended for JESD204B compliance. Bit7 – reserved Bit6:5 – reserved Bit4:2 – RATE, operating rate, select full, half, quarter or eighth rate operation. Bit1 – BUSWIDTH, select the parallel interface width (16 bit or 20bit). Note: 16bit is not compatible with JESD204B. Bit0 – SLEEPRX, powers the receiver down into sleep (fast power up) state when high. – reserved.	0x0000

REGISTER NAME: config63 – Address: 0x3F, Default: 0x0000					
Register Name	Addr (Hex)	Bit	Name	Function	Default Value
config63	0x3F	15:8	Not Used	Not Used	0x00
		7:0	INVPAIR	Allows the PN pairs of the SerDes lanes to be inverted. bit7 = lane7 bit6 = lane6 bit5 = lane5 bit4 = lane4 bit3 = lane3 bit2 = lane2 bit1 = lane1 bit0 = lane0	0x00

REGISTER NAME: config64 – Address: 0x40, Default: 0x0000					
Register Name	Addr (Hex)	Bit	Name	Function	Default Value
config64	0x40	15:0	reserved	Reserved	0x0000

REGISTER NAME: config65 – Address: 0x41, Default: 0x0000					
Register Name	Addr (Hex)	Bit	Name	Function	Default Value
config65 READ ONLY	0x41	15:0	errorcnt_link0	This is the error count for link0. What is counted as an error is determined by error_ena_link0. This is a 16bit value that is cleared when a JESD synchronization is performed or err_cnt_clr_link0 is programmed to a '1'.	0x0000

REGISTER NAME: config66 – Address: 0x42, Default: 0x0000					
Register Name	Addr (Hex)	Bit	Name	Function	Default Value
config66 READ ONLY	0x42	15:0	errorcnt_link1	This is the error count for link1. What is counted as an error is determined by error_ena_link1. This is a 16bit value that is cleared when a JESD synchronization is performed or err_cnt_clr_link0 is programmed to a '1'.	0x0000

REGISTER NAME: config67 – Address: 0x43, Default: 0x0000					
Register Name	Addr (Hex)	Bit	Name	Function	Default Value
config67 READ ONLY	0x43	15:0	errorcnt_link2	This is the error count for link2. What is counted as an error is determined by error_ena_link2. This is a 16bit value that is cleared when a JESD synchronization is performed or err_cnt_clr_link0 is programmed to a '1'.	0x0000

REGISTER NAME: config68 – Address: 0x44, Default: 0x0000					
Register Name	Addr (Hex)	Bit	Name	Function	Default Value
config68 READ ONLY	0x44	15:0	errorcnt_link3	This is the error count for link3. What is counted as an error is determined by error_ena_link3. This is a 16bit value that is cleared when a JESD synchronization is performed or err_cnt_clr_link0 is programmed to a '1'.	0x0000

REGISTER NAME: config69 – Address: 0x45, Default: 0x0000					
Register Name	Addr (Hex)	Bit	Name	Function	Default Value
config69	0x45	15:0	reserved	Reserved	0x0000

REGISTER NAME: config70 – Address: 0x46, Default: 0x0120					
Register Name	Addr (Hex)	Bit	Name	Function	Default Value
config70	0x46	15:11	lid0	The JESD ID for JESD lane 0.	00000
		10:6	lid1	The JESD ID for JESD lane 1.	00001
		5:1	lid2	The JESD ID for JESD lane 2.	00010
		0	reserved	Reserved	0

REGISTER NAME: config71 – Address: 0x47, Default: 0x3450					
Register Name	Addr (Hex)	Bit	Name	Function	Default Value
config71	0x47	15:11	lid3	The JESD ID for JESD lane 3.	00011
		10:6	lid4	The JESD ID for JESD lane 4.	00100
		5:1	lid5	The JESD ID for JESD lane 5.	00101
		0	reserved	Reserved	0

REGISTER NAME: config72 – Address: 0x48, Default: 0x31C3					
Register Name	Addr (Hex)	Bit	Name	Function	Default Value
config72	0x48	15:11	lid6	The JESD ID for JESD lane 6.	00110
		10:6	lid7	The JESD ID for JESD lane 7.	00111
		5:4	reserved	reserved	00
		3:1	subclassv	Selects the JESD subclass supported. Note: “001” is subclass 1 and this is the only mode supported	001
		0	jesdv	Selects the version of JESD supported (0=A, 1=B) Note: JESD 204B is only supported version.	1

REGISTER NAME: config73 – Address: 0x49, Default: 0x0000					
Register Name	Addr (Hex)	Bit	Name	Function	Default Value
config73	0x49	15:0	link_assign	Each JESD lane can be assigned to any of the 4 links. There are two bits for each lane: “00”=link0, “01”=link1, “10”=link2 and “11”=link3 bits(15:14) : JESD lane7 link selection bits(13:12) : JESD lane6 link selection bits(11:10) : JESD lane5 link selection bits(9:8) : JESD lane4 link selection bits(7:6) : JESD lane3 link selection bits(5:4) : JESD lane2 link selection bits(3:2) : JESD lane1 link selection bits(1:0) : JESD lane0 link selection	0x0000

REGISTER NAME: config74 – Address: 0x4A, Default: 0x001E					
Register Name	Addr (Hex)	Bit	Name	Function	Default Value
config74	0x4A	15:8	lane_ena	Turn on each SerDes lane as needed. Signal is active high. bit15 : SerDes lane7 enable bit14 : SerDes lane6 enable bit13 : SerDes lane5 enable bit12 : SerDes lane4 enable bit11 : SerDes lane3 enable bit10 : SerDes lane2 enable bit9 : SerDes lane1 enable bit8 : SerDes lane0 enable	0x00
		7:6	jesd_test_seq	Set to select and verify link layer test sequences. The error for these sequences comes out the lane alarms bit0. 1= fail and 0 = pass. 00 : test sequence disabled 01 : verify repeating D.21.5 high frequency pattern for random jitter 10 : verify repeating K.28.5 mixed frequency pattern for deterministic jitter 11 : verify repeating ILA sequence	00
		5	dual	Turn on "DUAL DAC" mode. This disables the clocks to the C and D data paths, reducing the power of the DIG block.	0
		4:1	init_state	Put the JESD block into "INIT_STATE" mode when high. During this mode the JESD can be programmed and its outputs will stay at zero. NOTE: See the JESD description of the correct startup sequence.	1111
		0	jesd_reset_n	Reset the JESD block when low. NOTE: See the JESD description of the correct startup sequence.	0

REGISTER NAME: config75 – Address: 0x4B, Default: 0x0000					
Register Name	Addr (Hex)	Bit	Name	Function	Default Value
config75	0x4B	15:13	reserved	Reserved	000
		12:8	rbd_m1	This controls the amount of elastic buffers being used in the JESD. Larger numbers will mean more latency, but smaller numbers may not hold enough data to capture the input skew. This value must always be $\leq k_m1$	00000
		7:0	f_m1	This is the number of octets in the frame. The DAC37J84/DAC38J84 only supports 1,2,4 or 8 octets per frame so the only valid values are 0,1,3, and 7.	0x00

REGISTER NAME: config76 – Address: 0x4C, Default: 0x0000					
Register Name	Addr (Hex)	Bit	Name	Function	Default Value
config76	0x4C	15:13	reserved	Reserved	000
		12:8	k_m1	This is the number of frames in a multi-frame. The range is 0-31.	00000
		7	reserved	Reserved	0
		6	reserved	Reserved	0
		5	reserved	Reserved	0
		4:0	l_m1	This is the number of lanes used by the JESD. Possible values are 0-7. 00000	00000

REGISTER NAME: config77 – Address: 0x4D, Default: 0x0300					
Register Name	Addr (Hex)	Bit	Name	Function	Default Value
config77	0x4D	15:8	m_m1	This is the number of converters per link. NOTE: Valid programmed values are 0, 1 and 3.	0x03
		7:5	reserved	Reserved	000
		4:0	s_m1	This is the number of converter samples per frame. NOTE: Valid programming is 0 or 1.	00000

REGISTER NAME: config78 – Address: 0x4E, Default: 0x0F0F					
Register Name	Addr (Hex)	Bit	Name	Function	Default Value
config78	0x4E	15:13	reserved	Reserved	000
		12:8	nprime_m1	This is the number of adjusted bits per sample. NOTE: 15 is the only valid value.	01111
		7	reserved	Reserved	0
		6	hd	High Density mode for the JESD. When asserted samples are split across lanes.	0
		5	scr	Turns on the scrambler function in the JESD block.	0
		4:0	n_m1	This is the number of bits per sample. NOTE: 15 is the only valid value.	01111

REGISTER NAME: config79 – Address: 0x4F, Default: 0x0000					
Register Name	Addr (Hex)	Bit	Name	Function	Default Value
config79	0x4F	15:8	match_data	The character to match. Normally it is a /R/=/K28.0/=0x1C, but the user can program it to any character.	00011100
		7	match_specific	Match a specified character to start JESD buffering when '1'. If programmed to '0' then the first non-K will start the buffering.	1
		6	match_ctrl	When asserted, the match character is a CONTROL character instead of a DATA character.	1
		5	no_lane_sync	Assert if the TX side does not support lane initialization. This way the RX won't flag errors in the configuration portion of the ILA.	0
		4:1	reserved	Reserved	0000
		0	jesd_commaalign_ena	always "1"	1

REGISTER NAME: config80 – Address: 0x50, Default: 0x0000					
Register Name	Addr (Hex)	Bit	Name	Function	Default Value
config80	0x50	15:12	adjcnt_link0	Lane configuration data for link0. Not used by DAC37J84/DAC38J84 except for lane configuration checking.	0000
		11	adjdir_link0	Lane configuration data for link0. Not used by DAC37J84/DAC38J84 except for lane configuration checking.	0
		10:7	bid_link0	Lane configuration data for link0. Not used by DAC37J84/DAC38J84 except for lane configuration checking.	0000
		6:2	cf_link0	Lane configuration data for link0. Not used by DAC37J84/DAC38J84 except for lane configuration checking.	00000
		1:0	cs_link0	Lane configuration data for link0. Not used by DAC37J84/DAC38J84 except for lane configuration checking.	00

REGISTER NAME: config81 – Address: 0x51, Default: 0x0000					
Register Name	Addr (Hex)	Bit	Name	Function	Default Value
config81	0x51	15:8	did_link0	Lane configuration data for link0. Not used by DAC37J84/DAC38J84 except for lane configuration checking.	0x00
		7:0	sync_request_ena_link0	These bits select which errors cause a sync request. Sync requests take priority over the error notification, so if sync request isn't desired, set these bits to a '0'. bit7 = multi-frame alignment error bit6 = frame alignment error bit5 = link configuration error bit4 = elastic buffer overflow (bad RBD value) bit3 = elastic buffer end char mismatch (match_ctrl match_data) bit2 = code synchronization error bit1 = 8b/10b not-in-table code error bit0 = 8b/10b disparity error	0xFF

REGISTER NAME: config82 – Address: 0x52, Default: 0x0000					
Register Name	Addr (Hex)	Bit	Name	Function	Default Value
config82	0x52	15:10	reserved	Reserved	000000
		9	disable_err_report_link0	Assertion means that errors will not be reported on the sync_n output.	0
		8	phadj_link0	Lane configuration data for link0. Not used by DAC37J84/DAC38J84 except for lane configuration checking.	0
		7:0	error_ena_link0	These bits select the errors generated are counted in the err_c for the link. The bits also control what signals are sent out the pad_syncb pin for error notification. bit7 = multi-frame alignment error bit6 = frame alignment error bit5 = link configuration error bit4 = elastic buffer overflow (bad RBD value) bit3 = elastic buffer end char mismatch (match_ctrl match_data) bit2 = code synchronization error bit1 = 8b/10b not-in-table code error bit0 = 8b/10b disparity error	0xFF

REGISTER NAME: config83 – Address: 0x53, Default: 0x0000					
Register Name	Addr (Hex)	Bit	Name	Function	Default Value
config83	0x53	15:12	adjcnt_link1	Lane configuration data for link1. Not used by DAC37J84/DAC38J84 except for lane configuration checking.	0000
		11	adjdir_link1	Lane configuration data for link1. Not used by DAC37J84/DAC38J84 except for lane configuration checking.	0
		10:7	bid_link1	Lane configuration data for link1. Not used by DAC37J84/DAC38J84 except for lane configuration checking.	0000
		6:2	cf_link1	Lane configuration data for link1. Not used by DAC37J84/DAC38J84 except for lane configuration checking.	00000
		1:0	cs_link1	Lane configuration data for link1. Not used by DAC37J84/DAC38J84 except for lane configuration checking.	00

REGISTER NAME: config84 – Address: 0x54, Default: 0x00FF					
Register Name	Addr (Hex)	Bit	Name	Function	Default Value
config84	0x54	15:8	did_link1	Lane configuration data for link1. Not used by DAC37J84/DAC38J84 except for lane configuration checking.	0x00
		7:0	sync_request_ena_link1	These bits select which errors cause a sync request. Sync requests take priority over the error notification, so if sync request isn't desired, set these bits to a '0'. bit7 = multi-frame alignment error bit6 = frame alignment error bit5 = link configuration error bit4 = elastic buffer overflow (bad RBD value) bit3 = elastic buffer end char mismatch (match_ctrl match_data) bit2 = code synchronization error bit1 = 8b/10b not-in-table code error bit0 = 8b/10b disparity error	0xFF

REGISTER NAME: config85 – Address: 0x55, Default: 0x0000					
Register Name	Addr (Hex)	Bit	Name	Function	Default Value
config85	0x55	15:10	reserved	Reserved	000000
		9	disable_err_report_link1	Assertion means that errors will not be reported on the sync_n output.	0
		8	phadj_link1	Lane configuration data for link1. Not used by DAC37J84/DAC38J84 except for lane configuration checking.	0
		7:0	error_ena_link1	These bits select the errors generated are counted in the err_cnt for the link. The bits also control what signals are sent out the pad_syncb pin for error notification. bit7 = multi-frame alignment error bit6 = frame alignment error bit5 = link configuration error bit4 = elastic buffer overflow (bad RBD value) bit3 = elastic buffer end char mismatch (match_ctrl match_data) bit2 = code synchronization error bit1 = 8b/10b not-in-table code error bit0 = 8b/10b disparity error	0xFF

REGISTER NAME: config86 – Address: 0x56, Default: 0x0000					
Register Name	Addr (Hex)	Bit	Name	Function	Default Value
config86	0x56	15:12	adjcnt_link2	Lane configuration data for link2. Not used by DAC37J84/DAC38J84 except for lane configuration checking.	0000
		11	adjdir_link2	Lane configuration data for link2. Not used by DAC37J84/DAC38J84 except for lane configuration checking.	0
		10:7	bid_link2	Lane configuration data for link2. Not used by DAC37J84/DAC38J84 except for lane configuration checking.	0000
		6:2	cf_link2	Lane configuration data for link2. Not used by DAC37J84/DAC38J84 except for lane configuration checking.	00000
		1:0	cs_link2	Lane configuration data for link2. Not used by DAC37J84/DAC38J84 except for lane configuration checking.	00

REGISTER NAME: config87 – Address: 0x57, Default: 0x00FF					
Register Name	Addr (Hex)	Bit	Name	Function	Default Value
config87	0x57	15:8	did_link2	Lane configuration data for link2. Not used by DAC37J84/DAC38J84 except for lane configuration checking.	0x00
		7:0	sync_request_ena_link2	These bits select which errors cause a sync request. Sync requests take priority over the error notification, so if sync request isn't desired, set these bits to a '0'. bit7 = multi-frame alignment error bit6 = frame alignment error bit5 = link configuration error bit4 = elastic buffer overflow (bad RBD value) bit3 = elastic buffer end char mismatch (match_ctrl match_data) bit2 = code synchronization error bit1 = 8b/10b not-in-table code error bit0 = 8b/10b disparity error	0xFF

REGISTER NAME: config88 – Address: 0x58, Default: 0x00FF					
Register Name	Addr (Hex)	Bit	Name	Function	Default Value
config88	0x58	15:10	reserved	Reserved	000000
		9	disable_err_report_link2	Assertion means that errors will not be reported on the sync_n output.	0
		8	phadj_link2	Lane configuration data for link2. Not used by DAC37J84/DAC38J84 except for lane configuration checking.	0
		7:0	error_ena_link2	These bits select the errors generated are counted in the err_cnt for the link. The bits also control what signals are sent out the pad_syncb pin for error notification. bit7 = multi-frame alignment error bit6 = frame alignment error bit5 = link configuration error bit4 = elastic buffer overflow (bad RBD value) bit3 = elastic buffer end char mismatch (match_ctrl match_data) bit2 = code synchronization error bit1 = 8b/10b not-in-table code error bit0 = 8b/10b disparity error	0xFF

REGISTER NAME: config89 – Address: 0x59, Default: 0x0000					
Register Name	Addr (Hex)	Bit	Name	Function	Default Value
config89	0x59	15:12	adjcnt_link3	Lane configuration data for link3. Not used by DAC37J84/DAC38J84 except for lane configuration checking.	0000
		11	adjdir_link3	Lane configuration data for link3. Not used by DAC37J84/DAC38J84 except for lane configuration checking.	0
		10:7	bid_link3	Lane configuration data for link3. Not used by DAC37J84/DAC38J84 except for lane configuration checking.	0000
		6:2	cf_link3	Lane configuration data for link3. Not used by DAC37J84/DAC38J84 except for lane configuration checking.	00000
		1:0	cs_link3	Lane configuration data for link3. Not used by DAC37J84/DAC38J84 except for lane configuration checking.	00

REGISTER NAME: config90 – Address: 0x5A, Default: 0x00FF					
Register Name	Addr (Hex)	Bit	Name	Function	Default Value
config90	0x5A	15:8	did_link3	Lane configuration data for link3. Not used by DAC37J84/DAC38J84 except for lane configuration checking.	0x00
		7:0	sync_request_ena_link3	These bits select which errors cause a sync request. Sync requests take priority over the error notification, so if sync request isn't desired, set these bits to a '0'. bit7 = multi-frame alignment error bit6 = frame alignment error bit5 = link configuration error bit4 = elastic buffer overflow (bad RBD value) bit3 = elastic buffer end char mismatch (match_ctrl match_data) bit2 = code synchronization error bit1 = 8b/10b not-in-table code error bit0 = 8b/10b disparity error	0xFF

REGISTER NAME: config91 – Address: 0x5B, Default: 0x00FF					
Register Name	Addr (Hex)	Bit	Name	Function	Default Value
config91	0x5B	15:10	reserved	Reserved	000000
		9	disable_err_report_link3	Assertion means that errors will not be reported on the sync_n output.	0
		8	phadj_link3	Lane configuration data for link3. Not used by DAC37J84/DAC38J84 except for lane configuration checking.	0
		7:0	error_ena_link3	These bits select the errors generated are counted in the err_cnt for the link. The bits also control what signals are sent out the pad_syncb pin for error notification. bit7 = multi-frame alignment error bit6 = frame alignment error bit5 = link configuration error bit4 = elastic buffer overflow (bad RBD value) bit3 = elastic buffer end char mismatch (match_ctrl match_data) bit2 = code synchronization error bit1 = 8b/10b not-in-table code error bit0 = 8b/10b disparity error	0xFF

REGISTER NAME: config92 – Address: 0x5C, Default: 0x1111					
Register Name	Addr (Hex)	Bit	Name	Function	Default Value
config92	0x5C	15	err_cnt_clr_link3	A transition from 0 \geq 1 causes the error_cnt for link3 to be cleared.	0
		14:12	sysref_mode_link3	Determines how SYSREF is used in the JESD synchronizing block. 000 = Don't use SYSREF pulse 001 = Use all SYSREF pulses 010 = Use only the next SYSREF pulse 011 = Skip one SYSREF pulse then use only the next one 100 = Skip one SYSREF pulse then use all pulses. 101 = Skip two SYSREF pulses then use only the next one 110 = Skip two SYSREF pulses then use all pulses.	001
		11	err_cnt_clr_link2	A transition from 0 \geq 1 causes the error_cnt for link2 to be cleared.	0
		10:8	sysref_mode_link2	Determines how SYSREF is used in the JESD synchronizing block. 000 = Don't use SYSREF pulse 001 = Use all SYSREF pulses 010 = Use only the next SYSREF pulse 011 = Skip one SYSREF pulse then use only the next one 100 = Skip one SYSREF pulse then use all pulses. 101 = Skip two SYSREF pulses then use only the next one 110 = Skip two SYSREF pulses then use all pulses.	001
		7	err_cnt_clr_link1	A transition from 0 \geq 1 causes the error_cnt for link1 to be cleared.	0
		6:4	sysref_mode_link1	Determines how SYSREF is used in the JESD synchronizing block. 000 = Don't use SYSREF pulse 001 = Use all SYSREF pulses 010 = Use only the next SYSREF pulse 011 = Skip one SYSREF pulse then use only the next one 100 = Skip one SYSREF pulse then use all pulses. 101 = Skip two SYSREF pulses then use only the next one 110 = Skip two SYSREF pulses then use all pulses.	001
		3	err_cnt_clr_link0	A transition from 0 \geq 1 causes the error_cnt for link0 to be cleared.	0
		2:0	sysref_mode_link0	Determines how SYSREF is used in the JESD synchronizing block. 000 = Don't use SYSREF pulse 001 = Use all SYSREF pulses 010 = Use only the next SYSREF pulse 011 = Skip one SYSREF pulse then use only the next one 100 = Skip one SYSREF pulse then use all pulses. 101 = Skip two SYSREF pulses then use only the next one 110 = Skip two SYSREF pulses then use all pulses.	001

PRODUCT PREVIEW

REGISTER NAME: config93 – Address: 0x5D, Default: 0x0000					
Register Name	Addr (Hex)	Bit	Name	Function	Default Value
config93	0x5D	15:0	reserved	Reserved	0x0000

REGISTER NAME: config94 – Address: 0x5E, Default: 0x0000					
Register Name	Addr (Hex)	Bit	Name	Function	Default Value
config94	0x5E	15:8	res1	Since these bits are reserved, these values are shared across all links for the checksum comparison against ILA values. Not used by DAC37J84/DAC38J84 except for lane configuration checking.	00000000
		7:0	res2	Since these bits are reserved, these values are shared across all links for the checksum comparison against ILA values. Not used by DAC37J84/DAC38J84 except for lane configuration checking.	

REGISTER NAME: config95 – Address: 0x5F, Default: 0x0000					
Register Name	Addr (Hex)	Bit	Name	Function	Default Value
config95	0x5F	15	reserved	Reserved	0
		14:12	octetpath_sel(0)	These bits are used by the cross-bar switch to map any SerDes lane to any JESD lane. "000" = pass SerDes lane0 to JESD lane0 "001" = pass SerDes lane1 to JESD lane0 "010" = pass SerDes lane2 to JESD lane0 "011" = pass SerDes lane3 to JESD lane0 "100" = pass SerDes lane4 to JESD lane0 "101" = pass SerDes lane5 to JESD lane0 "110" = pass SerDes lane6 to JESD lane0 "111" = pass SerDes lane7 to JESD lane0	000
		11	reserved	Reserved	0
		10:8	octetpath_sel(1)	These bits are used by the cross-bar switch to map any SerDes lane to any JESD lane. "000" = pass SerDes lane0 to JESD lane1 "001" = pass SerDes lane1 to JESD lane1 "010" = pass SerDes lane2 to JESD lane1 "011" = pass SerDes lane3 to JESD lane1 "100" = pass SerDes lane4 to JESD lane1 "101" = pass SerDes lane5 to JESD lane1 "110" = pass SerDes lane6 to JESD lane1 "111" = pass SerDes lane7 to JESD lane1	001
		7	reserved	Reserved	0
		6:4	octetpath_sel(2)	These bits are used by the cross-bar switch to map any SerDes lane to any JESD lane. "000" = pass SerDes lane0 to JESD lane2 "001" = pass SerDes lane1 to JESD lane2 "010" = pass SerDes lane2 to JESD lane2 "011" = pass SerDes lane3 to JESD lane2 "100" = pass SerDes lane4 to JESD lane2 "101" = pass SerDes lane5 to JESD lane2 "110" = pass SerDes lane6 to JESD lane2 "111" = pass SerDes lane7 to JESD lane2	010
		3	reserved	Reserved	0
		2:0	octetpath_sel(3)	These bits are used by the cross-bar switch to map any SerDes lane to any JESD lane. "000" = pass SerDes lane0 to JESD lane3 "001" = pass SerDes lane1 to JESD lane3 "010" = pass SerDes lane2 to JESD lane3 "011" = pass SerDes lane3 to JESD lane3 "100" = pass SerDes lane4 to JESD lane3 "101" = pass SerDes lane5 to JESD lane3 "110" = pass SerDes lane6 to JESD lane3 "111" = pass SerDes lane7 to JESD lane3	011

PRODUCT PREVIEW

REGISTER NAME: config96 – Address: 0x60, Default: 0x4567					
Register Name	Addr (Hex)	Bit	Name	Function	Default Value
config96	0x60	15	reserved	Reserved	0
		14:12	octetpath_sel(4)	These bits are used by the cross-bar switch to map any SerDes lane to any JESD lane. "000" = pass SerDes lane0 to JESD lane4 "001" = pass SerDes lane1 to JESD lane4 "010" = pass SerDes lane2 to JESD lane4 "011" = pass SerDes lane3 to JESD lane4 "100" = pass SerDes lane4 to JESD lane4 "101" = pass SerDes lane5 to JESD lane4 "110" = pass SerDes lane6 to JESD lane4 "111" = pass SerDes lane7 to JESD lane4	100
		11	reserved	Reserved	0
		10:8	octetpath_sel(5)	These bits are used by the cross-bar switch to map any SerDes lane to any JESD lane. "000" = pass SerDes lane0 to JESD lane5 "001" = pass SerDes lane1 to JESD lane5 "010" = pass SerDes lane2 to JESD lane5 "011" = pass SerDes lane3 to JESD lane5 "100" = pass SerDes lane4 to JESD lane5 "101" = pass SerDes lane5 to JESD lane5 "110" = pass SerDes lane6 to JESD lane5 "111" = pass SerDes lane7 to JESD lane5	101
		7	reserved	Reserved	0
		6:4	octetpath_sel(6)	These bits are used by the cross-bar switch to map any SerDes lane to any JESD lane. "000" = pass SerDes lane0 to JESD lane6 "001" = pass SerDes lane1 to JESD lane6 "010" = pass SerDes lane2 to JESD lane6 "011" = pass SerDes lane3 to JESD lane6 "100" = pass SerDes lane4 to JESD lane6 "101" = pass SerDes lane5 to JESD lane6 "110" = pass SerDes lane6 to JESD lane6 "111" = pass SerDes lane7 to JESD lane6	110
		3	reserved	Reserved	0
		2:0	octetpath_sel(7)	These bits are used by the cross-bar switch to map any SerDes lane to any JESD lane. "000" = pass SerDes lane0 to JESD lane7 "001" = pass SerDes lane1 to JESD lane7 "010" = pass SerDes lane2 to JESD lane7 "011" = pass SerDes lane3 to JESD lane7 "100" = pass SerDes lane4 to JESD lane7 "101" = pass SerDes lane5 to JESD lane7 "110" = pass SerDes lane6 to JESD lane7 "111" = pass SerDes lane7 to JESD lane7	111

PRODUCT PREVIEW

REGISTER NAME: config97 – Address: 0x61, Default: 0x000F					
Register Name	Addr (Hex)	Bit	Name	Function	Default Value
config97	0x61	15	syncn_pol	Sets the polarity of the SYNC_N_AB and SYNC_N_CD outputs.	0
		14:2	reserved	Reserved	000
		11:8	syncncd_sel	Select which link sync_n outputs are ANDed together to generate the SYNC_N_CD CMOS output. bit0=link0 bit1=link1 bit2=link2 bit3=link3	0000
		7:4	syncnab_sel	Select which link sync_n outputs are ANDed together to generate the SYNC_N_AB CMOS output. bit0=link0 bit1=link1 bit2=link2 bit3=link3	0000
		3:0	syncn_sel	Select which link sync_n outputs are ANDed together to generate the SYNCB LVDS output. bit0=link0 bit1=link1 bit2=link2 bit3=link3	1111

REGISTER NAME: config98 – Address: 0x62, Default: 0x0000					
Register Name	Addr (Hex)	Bit	Name	Function	Default Value
config98	0x62	15	reserved	Reserved	0
		14:12	reserved	Reserved	000
		11:8	reserved	Reserved	0000
		7:0	reserved	Reserved	0x00

REGISTER NAME: config99 – Address: 0x63, Default: 0x0000					
Register Name	Addr (Hex)	Bit	Name	Function	Default Value
config99	0x63	15	reserved	Reserved	0
		14:12	reserved	Reserved	000
		11:8	reserved	Reserved	0000
		7:0	reserved	Reserved	0000

Addresses config100 – config107 are dual purpose registers. When config47(14) is set to a ‘1’ then config100 – config107 become the DIEID(127:0). Normal function (config47(14)=‘0’) is shown below.

REGISTER NAME: config100 – Address: 0x64, Default: 0x0000					
Register Name	Addr (Hex)	Bit	Name	Function	Default Value
config100 WRITE TO CLEAR	0x64	15:8	alarm_l_ error(0)	Lane0 errors: bit15 = multiframe alignment error bit14 = frame alignment error bit13 = link configuration error bit12 = elastic buffer overflow (bad RBD value) bit11 = elastic buffer match error. The first non-/K/ doesn't match "match_ctrl" and "match_data" programmed values. bit10 = code synchronization error bit9 = 8b/10b not-in-table code error bit8 = 8b/10b disparity error	0x00
		7:4	Not Used	Not Used	0000
		3:0	alarm_fifo_ flags(0)	Lane0 FIFO errors: bit3 = write_error : Asserted if write request and FIFO is full bit2 = write_full : FIFO is FULL bit1 = read_error : Asserted if read request with empty FIFO bit0 = read_empty : FIFO is empty	0000

REGISTER NAME: config101 – Address: 0x65, Default: 0x0000					
Register Name	Addr (Hex)	Bit	Name	Function	Default Value
config101 WRITE TO CLEAR	0x65	15:8	alarm_l_ error(1)	Lane0 errors: bit15 = multiframe alignment error bit14 = frame alignment error bit13 = link configuration error bit12 = elastic buffer overflow (bad RBD value) bit11 = elastic buffer match error. The first non-/K/ doesn't match "match_ctrl" and "match_data" programmed values. bit10 = code synchronization error bit9 = 8b/10b not-in-table code error bit8 = 8b/10b disparity error	0x00
		7:4	Not Used	Not Used	0000
		3:0	alarm_fifo_ flags(0)	Lane0 FIFO errors: bit3 = write_error : Asserted if write request and FIFO is full bit2 = write_full : FIFO is FULL bit1 = read_error : Asserted if read request with empty FIFO bit0 = read_empty : FIFO is empty	0000

REGISTER NAME: config102 – Address: 0x66, Default: 0x0000					
Register Name	Addr (Hex)	Bit	Name	Function	Default Value
config102 WRITE TO CLEAR	0x66	15:8	alarm_lane_error(2)	Lane0 errors: bit15 = multiframe alignment error bit14 = frame alignment error bit13 = link configuration error bit12 = elastic buffer overflow (bad RBD value) bit11 = elastic buffer match error. The first non-/K/ doesn't match "match_ctrl" and "match_data" programmed values. bit10 = code synchronization error bit9 = 8b/10b not-in-table code error bit8 = 8b/10b disparity error	0x00
		7:4	reserved	Reserved	0000
		3:0	alarm_fifo_flags(0)	Lane0 FIFO errors: bit3 = write_error : Asserted if write request and FIFO is full bit2 = write_full : FIFO is FULL bit1 = read_error : Asserted if read request with empty FIFO bit0 = read_empty : FIFO is empty	0000

REGISTER NAME: config103 – Address: 0x67, Default: 0x0000					
Register Name	Addr (Hex)	Bit	Name	Function	Default Value
config103 WRITE TO CLEAR	0x67	15:8	alarm_land_error(3)	Lane0 errors: bit15 = multiframe alignment error bit14 = frame alignment error bit13 = link configuration error bit12 = elastic buffer overflow (bad RBD value) bit11 = elastic buffer match error. The first non-/K/ doesn't match "match_ctrl" and "match_data" programmed values. bit10 = code synchronization error bit9 = 8b/10b not-in-table code error bit8 = 8b/10b disparity error	0x00
		7:4	reserved	Reserved	0000
		3:0	alarm_fifo_flags(0)	Lane0 FIFO errors: bit3 = write_error : Asserted if write request and FIFO is full bit2 = write_full : FIFO is FULL bit1 = read_error : Asserted if read request with empty FIFO bit0 = read_empty : FIFO is empty	0000

REGISTER NAME: config104 – Address: 0x68, Default: 0x0000					
Register Name	Addr (Hex)	Bit	Name	Function	Default Value
config104 WRITE TO CLEAR	0x68	15:8	alarm_lane_error(4)	Lane0 errors: bit15 = multiframe alignment error bit14 = frame alignment error bit13 = link configuration error bit12 = elastic buffer overflow (bad RBD value) bit11 = elastic buffer match error. The first non-/K/ doesn't match "match_ctrl" and "match_data" programmed values. bit10 = code synchronization error bit9 = 8b/10b not-in-table code error bit8 = 8b/10b disparity error	0x00
		7:4	reserved	Reserved	0000
		3:0	alarm_fifo_flags(0)	Lane0 FIFO errors: bit3 = write_error : Asserted if write request and FIFO is full bit2 = write_full : FIFO is FULL bit1 = read_error : Asserted if read request with empty FIFO bit0 = read_empty : FIFO is empty	0000

PRODUCT PREVIEW

REGISTER NAME: config105 – Address: 0x69, Default: 0x0000					
Register Name	Addr (Hex)	Bit	Name	Function	Default Value
config105 WRITE TO CLEAR	0x69	15:8	alarm_lane_error(5)	Lane0 errors: bit15 = multiframe alignment error bit14 = frame alignment error bit13 = link configuration error bit12 = elastic buffer overflow (bad RBD value) bit11 = elastic buffer match error. The first non-/K/ doesn't match "match_ctrl" and "match_data" programmed values. bit10 = code synchronization error bit9 = 8b/10b not-in-table code error bit8 = 8b/10b disparity error	0x00
		7:4	reserved	Reserved	0000
		3:0	alarm_fifo_flags(0)	Lane0 FIFO errors: bit3 = write_error : Asserted if write request and FIFO is full bit2 = write_full : FIFO is FULL bit1 = read_error : Asserted if read request with empty FIFO bit0 = read_empty : FIFO is empty	0000

REGISTER NAME: config106 – Address: 0x6A, Default: 0x0000					
Register Name	Addr (Hex)	Bit	Name	Function	Default Value
config106 WRITE TO CLEAR	0x6A	15:8	alarm_lane_error(6)	Lane0 errors: bit15 = multiframe alignment error bit14 = frame alignment error bit13 = link configuration error bit12 = elastic buffer overflow (bad RBD value) bit11 = elastic buffer match error. The first non-/K/ doesn't match "match_ctrl" and "match_data" programmed values. bit10 = code synchronization error bit9 = 8b/10b not-in-table code error bit8 = 8b/10b disparity error	0x00
		7:4	reserved	Reserved	0000
		3:0	alarm_fifo_flags(0)	Lane0 FIFO errors: bit3 = write_error : Asserted if write request and FIFO is full bit2 = write_full : FIFO is FULL bit1 = read_error : Asserted if read request with empty FIFO bit0 = read_empty : FIFO is empty	0000

REGISTER NAME: config107 – Address: 0x6B, Default: 0x0000					
Register Name	Addr (Hex)	Bit	Name	Function	Default Value
config107 WRITE TO CLEAR	0x6B	15:8	alarm_lane_error(7)	Lane7 errors: bit15 = multiframe alignment error bit14 = frame alignment error bit13 = link configuration error bit12 = elastic buffer overflow (bad RBD value) bit11 = elastic buffer match error. The first non-/K/ doesn't match "match_ctrl" and "match_data" programmed values. bit10 = code synchronization error bit9 = 8b/10b not-in-table code error bit8 = 8b/10b disparity error	0x00
		7:4	reserved	Reserved	0000
		3:0	alarm_fifo_flags(0)	Lane0 FIFO errors: bit3 = write_error : Asserted if write request and FIFO is full bit2 = write_full : FIFO is FULL bit1 = read_error : Asserted if read request with empty FIFO bit0 = read_empty : FIFO is empty	0000

REGISTER NAME: config108 – Address: 0x6C, Default: 0x0000					
Register Name	Addr (Hex)	Bit	Name	Function	Default Value
config108 WRITE TO CLEAR	0x6C	15:12	alarm_sysref_err	SYSREF Errors discovered for each lane. bit15 = lane3 bit14 = lane2 bit13 = lane1 bit12 = lane0	0000
		11:8	alarm_pap	Alarms from the PAP blocks bit11 = data path D bit10 = data path C bit9 = data path B bit8 = data path A While any alarm_pap is asserted the attenuation for the appropriate data path is applied.	0000
		7:4	reserved	Reserved	0000
		3	alarm_rw0_pll	Driven high if the PLL in the SerDes block0 goes out of lock. A false alarm is generated at startup when the PLL is locking. User will have to reset this bit after start to monitor accurately.	0
		2	alarm_rw1_pll	Driven high if the PLL in the SerDes block1 goes out of lock. A false alarm is generated at startup when the PLL is locking. User will have to reset this bit after start to monitor accurately.	0
		1	reserved	Reserved	0
		0	alarm_from_pll	When this bit is a '1' the DAC PLL is out of lock.	0

REGISTER NAME: config109 – Address: 0x6D, Default: 0x00xx					
Register Name	Addr (Hex)	Bit	Name	Function	Default Value
config109	0x6D	15:8	alarm_from_shorttest	These are the alarms from the different lanes during JESD short test checking. bit15 = lane7 alarm bit14 = lane6 alarm bit13 = lane5 alarm bit12 = lane4 alarm bit11 = lane3 alarm bit10 = lane2 alarm bit9 = lane1 alarm bit8 = lane0 alarm	0x00
		7:0	memin_rw_losdct	These are the loss of signal detect outputs from the SERDES lanes: bit7 = lane7 loss off signal bit6 = lane6 loss off signal bit5 = lane5 loss off signal bit4 = lane4 loss off signal bit3 = lane3 loss off signal bit2 = lane2 loss off signal bit1 = lane1 loss off signal bit0 = lane0 loss off signal	No default

REGISTER NAME: config110 – Address: 0x6E, Default: 0x0000					
Register Name	Addr (Hex)	Bit	Name	Function	Default Value
config110	0x6E	15:14	sfrac_coef0_ab	Small delay fractional filter tap0: Valid values [-2 to 1]	00
		13:9	sfrac_coef1_ab	Small delay fractional filter tap1: Valid values [-16 to 15]	00000
		8:1	sfrac_coef2_ab	Small delay fractional filter tap2: Valid values [-128 127]	00000000
		0	reserved	Reserved	0

REGISTER NAME: config111 – Address: 0x6F, Default: 0x0000					
Register Name	Addr (Hex)	Bit	Name	Function	Default Value
config111	0x6F	15:10	reserved	Reserved	000000
		9:0	sfrac_coef3_ab	Small delay fractional filter tap3: Valid values [-512 to 511]	0000000000

REGISTER NAME: config112 – Address: 0x70, Default: 0x0000					
Register Name	Addr (Hex)	Bit	Name	Function	Default Value
config112	0x70	15:0	sfrac_coef4_ab(15:0)	Small delay fractional filter tap4: Valid values [-262144 to 262143]	0x0000

REGISTER NAME: config113 – Address: 0x71, Default: 0x0000					
Register Name	Addr (Hex)	Bit	Name	Function	Default Value
config113	0x71	15:13	sfrac_coef4_ab(18:16)	Upper bits of small delay fraction filter tap4.	000
		12:10	reserved	Reserved	000
		9:0	sfrac_coef5_ab	Small delay fractional filter tap5: Valid values [-512 to 511]	0000000000

REGISTER NAME: config114 – Address: 0x72, Default: 0x0000					
Register Name	Addr (Hex)	Bit	Name	Function	Default Value
config114	0x72	15:9	reserved	Reserved	00000000
		8:0	sfrac_coef6_ab	Small delay fractional filter tap6: Valid values [-256 to 255]	0000000000

REGISTER NAME: config115 – Address: 0x73, Default: 0x0000					
Register Name	Addr (Hex)	Bit	Name	Function	Default Value
config115	0x73	15:9	sfrac_coef7_ab	Small delay fractional filter tap7: Valid values [-64 to 63]	00000000
		8:4	sfrac_coef8_ab	Small delay fractional filter tap8: Valid values [-16 to 15]	000000
		3:2	sfrac_coef9_ab	Small delay fractional filter tap9: Valid values [-2 to 1]	00
		1:0	Not Used	Not Used	00

REGISTER NAME: config16 – Address: 0x74, Default: 0x0000					
Register Name	Addr (Hex)	Bit	Name	Function	Default Value
config16	0x74	15:0	sfrac_invgain_ab(15:0)	Controls the divide amount in the small fractional delay gain computation: Valid values [-524288 to 524284]	0x0000

REGISTER NAME: config117 – Address: 0x75, Default: 0x0000					
Register Name	Addr (Hex)	Bit	Name	Function	Default Value
config117	0x75	15:12	sfrac_invgain_ab(19:16)	Upper bits of the small fraction delay FIR gain value.	0000
		11:3	reserved	Reserved	0000000000
		5:3	lfrac_coefsel_a	Selected that coefficients used for the A data path FIR5B or large fractional delay FIR.	000
		2:0	lfrac_coefsel_b	Selected that coefficients used for the B data path FIR5B or large fractional delay FIR.	000

REGISTER NAME: config118 – Address: 0x76, Default: 0x0000					
Register Name	Addr (Hex)	Bit	Name	Function	Default Value
config118	0x76	15:14	sfrac_coef0_cd	Small delay fractional filter tap0: Valid values [–2 to 1]	00
		13:9	sfrac_coef1_cd	Small delay fractional filter tap1: Valid values [–16 to 15]	00000
		8:1	sfrac_coef2_cd	Small delay fractional filter tap2: Valid values [–128 127]	00000000
		0	reserved	Reserved	0

REGISTER NAME: config119 – Address: 0x77, Default: 0x0000					
Register Name	Addr (Hex)	Bit	Name	Function	Default Value
config119	0x77	15:10	reserved	Reserved	000000
		9:0	sfrac_coef3_cd	Small delay fractional filter tap3: Valid values [–512 to 511]	0000000000

REGISTER NAME: config120 – Address: 0x78, Default: 0x0000					
Register Name	Addr (Hex)	Bit	Name	Function	Default Value
config120	0x78	15:0	sfrac_coef4_cd(15:0)	Small delay fractional filter tap4: Valid values [–262144 to 262143]	0x0000

REGISTER NAME: config121 – Address: 0x79, Default: 0x0000					
Register Name	Addr (Hex)	Bit	Name	Function	Default Value
config121	0x79	15:13	sfrac_coef4_cd(18:16)	Upper bits of small delay fraction filter tap4.	000
		12:10	reserved	Reserved	000
		9:0	sfrac_coef5_cd	Small delay fractional filter tap5: Valid values [–512 to 511]	0000000000

REGISTER NAME: config122 – Address: 0x7A, Default: 0x0000					
Register Name	Addr (Hex)	Bit	Name	Function	Default Value
config122	0x7A	15:9	reserved	Reserved	0000000
		8:0	sfrac_coef6_cd	Small delay fractional filter tap6: Valid values [–256 to 255]	

REGISTER NAME: config123 – Address: 0x7B, Default: 0x0000					
Register Name	Addr (Hex)	Bit	Name	Function	Default Value
config123	0x7B	15:9	sfrac_coef7_cd	Small delay fractional filter tap7: Valid values [–64 to 63]	0000000
		8:4	sfrac_coef8_cd	Small delay fractional filter tap8: Valid values [–16 to 15]	00000
		3:2	sfrac_coef9_cd	Small delay fractional filter tap9: Valid values [–2 to 1]	00
		1:0	Not Used	Not Used	00

REGISTER NAME: config124 – Address: 0x7C, Default: 0x0000					
Register Name	Addr (Hex)	Bit	Name	Function	Default Value
config124	0x7C	15:0	sfrac_invgain_cd(15:0)	Controls the divide amount in the small fractional delay gain computation: Valid values [–524288 to 524284]	0x0000

REGISTER NAME: config125 – Address: 0x7D, Default: 0x0000					
Register Name	Addr (Hex)	Bit	Name	Function	Default Value
config125	0x7D	15:12	sfrac_invgain_cd(19:16)	Upper bits of the small fraction delay FIR gain value.	0000
		11:6	reserved	Reserved	000000000
		5:3	lfrac_coefssel_c	Selected that coefficients used for the C data path FIR5B or large fractional delay FIR.	000
		2:0	lfrac_coefssel_d	Selected that coefficients used for the D data path FIR5B or large fractional delay FIR.	000

REGISTER NAME: config126 – Address: 0x7E, Default: 0x0000					
Register Name	Addr (Hex)	Bit	Name	Function	Default Value
config126	0x7E	15:12	reserved	Reserved	0000
		11:8	reserved	Reserved	0000
		7:4	reserved	Reserved	0000
		3:0	reserved	Reserved	0000

REGISTER NAME: config127 – Address: 0x7F, Default: 0x0000					
Register Name	Addr (Hex)	Bit	Name	Function	Default Value
config127 READ ONLY/No RESET Value	0x7F	15	memin_efc_autoload_done	Goes high when the autoload from the fusefarm is done.	0
		14:10	memin_efc_error	Resulting error code from last Fusefarm instruction	00000
		9:8	not used	Not Used	00
		7:5	not used	Not Used	000
		4:3	vendorid	This is the vendor ID. It shouldn't change but will have access to change through a hardwire connection outside the DIG block.	01
		2:0	versionid	A hardwired register that contains the version of the chip. This value is accessible outside the DIG block for changing.	001

CLOCKING MODES

The DAC37J82/DAC38J82 has a single differential clock DACCLKN/P to clock the DAC cores and internal digital logic. The DAC37J82/DAC38J82 DACCLK can be sourced directly or generated through an on-chip low-jitter phase-locked loop (PLL).

In those applications requiring extremely low noise it is recommended to bypass the PLL and source the DAC clock directly from a high-quality external clock to the DACCLK input. In most applications system clocking can be simplified by using the on-chip PLL to generate the DAC core clock while still satisfying performance requirements. In this case the DACCLK pins are used as the reference frequency input to the PLL.

PLL Bypass Mode

In PLL bypass mode a high quality clock is sourced to the DACCLK inputs. This clock is used to directly clock the DAC37J82/DAC38J82 DAC cores. This mode gives the device best performance and is recommended for extremely demanding applications.

The bypass mode is selected by setting the following:

1. **mem_pll_ena** bit in register *config49* to “0” to bypass the PLL circuitry.
2. **mem_pll_sleep** bit in register *config26* to “1” to put the PLL and VCO into sleep mode.

PLL Mode

In this mode the clock at the DACCLK input functions as a reference clock source to the on-chip PLL. The on-chip PLL will then multiply this reference clock to supply a higher frequency DAC cores clock. Figure 6 shows the block diagram of the PLL circuit, where N divider ratio ranges from 1 to 32, M divider ratio ranges from 1 to 256, and VCO prescaler divider from 2 to 18.

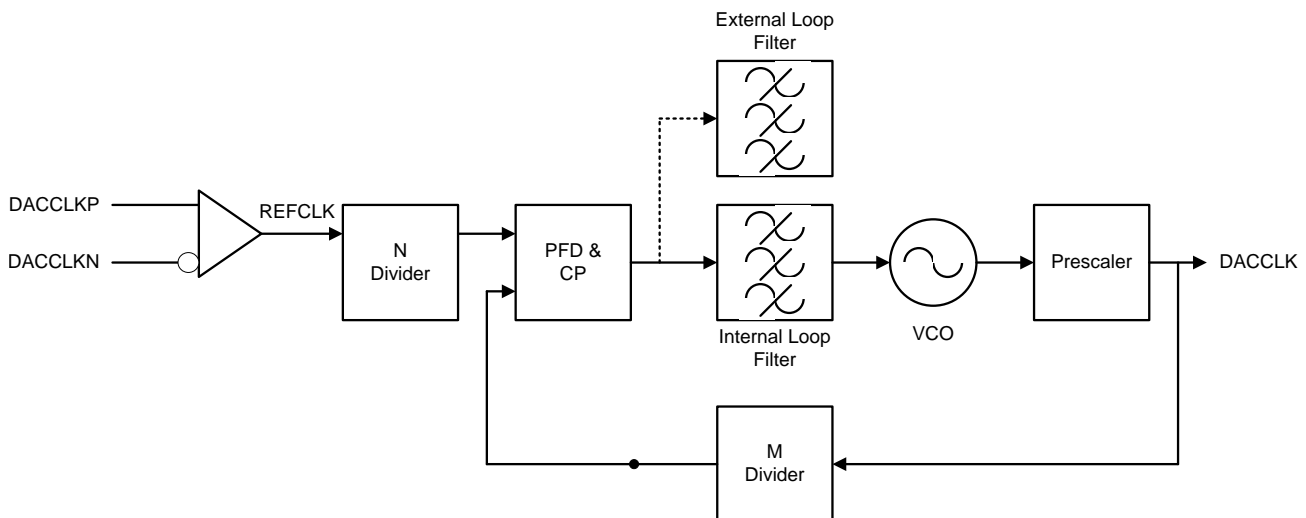

Figure 6. PLL Block Diagram

The DAC37J82/DAC38J82 PLL mode is selected by setting the following:

1. **mem_pll_ena** bit in register *config49* to “1” to route to the PLL and clock path.
2. **mem_pll_sleep** bit in register *config26* to “0” to enable the PLL and VCO.

The output frequency of the VCO covers two frequency spans: H-band (4.44-5.6GHz) and L-band (3.7-4.66GHz). When **mem_pll_vcose1** in register *config51* is “1”, the L-band is selected; when **mem_pll_vcose1** is “0”, the H-band is selected. At each band, the VCO range can be further adjusted by using the 6-bits **mem_pll_vco** in register *config51*. Common wireless infrastructure frequencies are generated from this VCO frequency in conjunction with the pre-scaler setting **mem_pll_p** in register *config50* as shown in Table 14. When there are multiple valid VCO frequency and the pre-scaler settings to generate the same desired DACCLK frequency, higher pre-scaler divider ratio is recommended for better phase noise performance.

Table 15. VCO Operation

VCO Frequency (MHz)	mem_pll_vcose1	Pre-Scale Divider	Desired DACCLK (MHz)	mem_pll_p(3:0)
4915.2	0	2	2457.6	0000
3932.16	1	2	1966.08	0000
4423.68	1	3	1474.56	0001
4915.2	0	4	1228.8	0010
4915.2	0	5	983.04	0011
5160.96	0	7	737.28	0101
4915.2	0	8	614.4	0110
4915.2	0	10	491.52	0111

The M divider is used to determine the phase-frequency-detector (PFD) and charge-pump (CP) frequency.

Table 16. PFD and CP Operation

DACCLK Frequency (MHz)	M Divider	PFD Update Rate (MHz)	pll_m(7:0)
1474.56	12	122.88	00001011
1474.56	24	61.44	00010111
1474.56	48	30.72	00101111
1474.56	64	15.36	00111111

The N divider in the loop allows the PFD to operate at a lower frequency than the reference clock.

The overall divide ratio inside the loop is the product of the Pre-Scale and M dividers (P*M). The 5-bit *mem_pll_cp_adj* is to set the charge pump current from 0 to 1.55mA with a step of 50µA. In nominal condition, if vco runs at 5GHz with P-ratio and M-ratio set as 2 and 4, the DACCLK frequency would be 2.5GHz and PFD frequency 625MHz. This needs 600µA charge pump current to stabilize the loop and gives the optimized phase noise performance. When P*M ratio increases, the charge pump current needs to be increased accordingly to sustain enough phase margin for the loop. By tuning the charge pump current, a wide range of PM ratio can be supported with the internal loop filter. In very extreme cases when the P*M ratio is huge (ex. PFD frequency of 10MHz, VCO frequency of 4GHz) and the loop cannot be stabilized even with the largest charge pump current, an external loop filter is required.

If an external filter is required, the following filter should be connected to the LPF pin (C9):

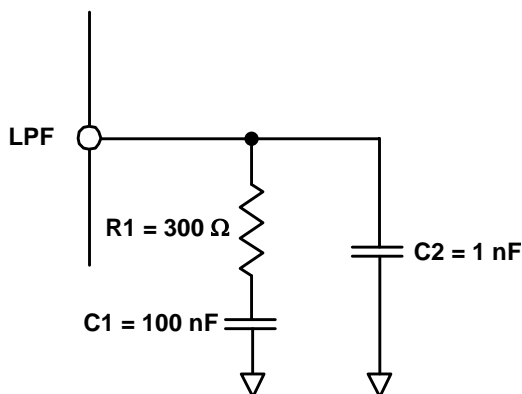

Figure 7. Recommended External Loop Filter

MULTI-DEVICE SYNCHRONIZATION

In many applications, such as multi antenna systems where the various transmit channels information is correlated, it is required that the latency across the link is deterministic and multiple DAC devices are completely synchronized such that their outputs are phase aligned. DAC37J82/DAC38J82 achieves the deterministic latency using SYSREF (JESD204B Subclass 1).

SYSREF is generated from the same clock domain as DACCLK, and is sampled at the rising edges of the device clock. It can be periodic, single-shot or “gapped” periodic. After having resynchronized its local multiframe clock (LMFC) to SYSREF, the DAC will request a link re-initialization via SYNC interface. Processing of the signal on the SYSREF input can be enabled and disabled via the SPI interface.

INPUT MULTIPLEXER

The DAC37J82/DAC38J82 includes a multiplexer after the JESD204B interface that allows any input stream A-B to be routed to any signal channel A-B. See *mem_pathx_in_sel* for details on how to configure the cross-bar switches.

FIR FILTERS

through show the magnitude spectrum response for the FIR0, FIR1, FIR2 and FIR3 interpolating filters where f_{IN} is the input data rate to the FIR filter. to show the composite filter response for 2x, 4x, 8x and 16x interpolation. The transition band for all interpolation settings is from 0.4 to $0.6 \times f_{DATA}$ (the input data rate to the device) with < 0.001 dB of pass-band ripple and > 90 dB stop-band attenuation.

The DAC37J82/DAC38J82 includes a no interpolation 1x mode. However, the input data rate in this mode is limited to 1230MSPS. See more details in [Table 10](#) and [Table 11](#).

The DAC37J82/DAC38J82 also has a 9-tap inverse sinc filter (FIR4) that runs at the DAC update rate (f_{DAC}) that can be used to flatten the frequency response of the sample-and-hold output. The DAC sample-and-hold output sets the output current and holds it constant for one DAC clock cycle until the next sample, resulting in the well-known $\sin(x)/x$ or $\text{sinc}(x)$ frequency response (, red line). The inverse sinc filter response (, blue line) has the opposite frequency response from 0 to $0.4 \times f_{DAC}$, resulting in the combined response (, green line). Between 0 to $0.4 \times f_{DAC}$, the inverse sinc filter compensates the sample-and-hold roll-off with less than 0.03 dB error.

The inverse sinc filter has a gain > 1 at all frequencies. Therefore, the signal input to FIR4 must be reduced from full scale to prevent saturation in the filter. The amount of back-off required depends on the signal frequency, and is set such that at the signal frequencies the combination of the input signal and filter response is less than 1 (0 dB). For example, if the signal input to FIR4 is at $0.25 \times f_{DAC}$, the response of FIR4 is 0.9 dB, and the signal must be backed off from full scale by 0.9 dB to avoid saturation. The gain function in the QMC blocks can be used to reduce the amplitude of the input signal. The advantage of FIR4 having a positive gain at all frequencies is that the user is then able to optimize the back-off of the signal based on its frequency.

The filter taps for all digital filters are listed in [Table 16](#). Note that the loss of signal amplitude may result in lower SNR due to decrease in signal amplitude.

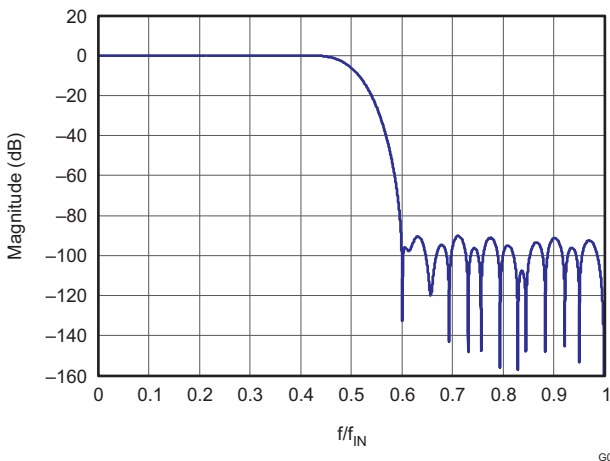

Figure 8. Magnitude Spectrum for FIR0

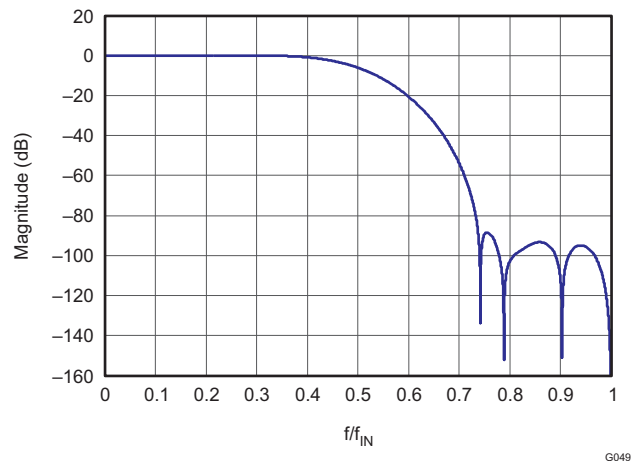

Figure 9. Magnitude Spectrum for FIR1

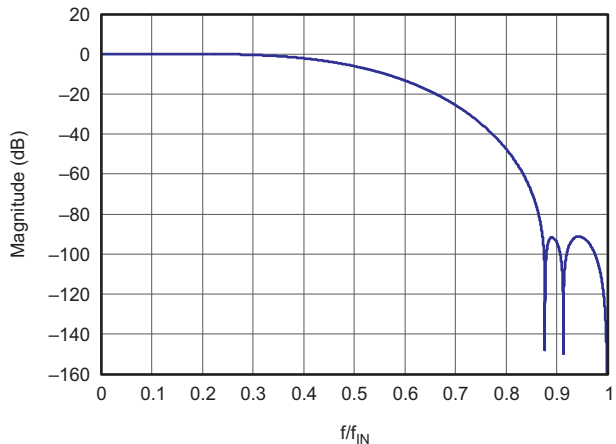

Figure 10. Magnitude Spectrum for FIR2

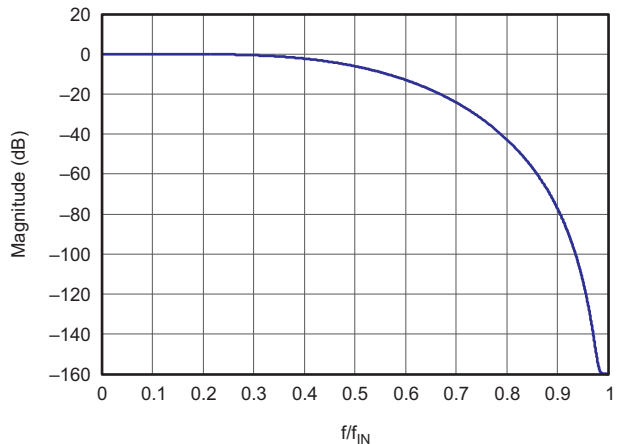

Figure 11. Magnitude Spectrum for FIR3

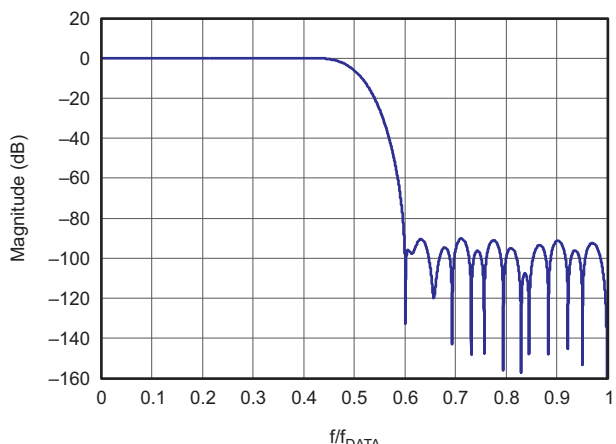

Figure 12. 2x Interpolation Composite Response

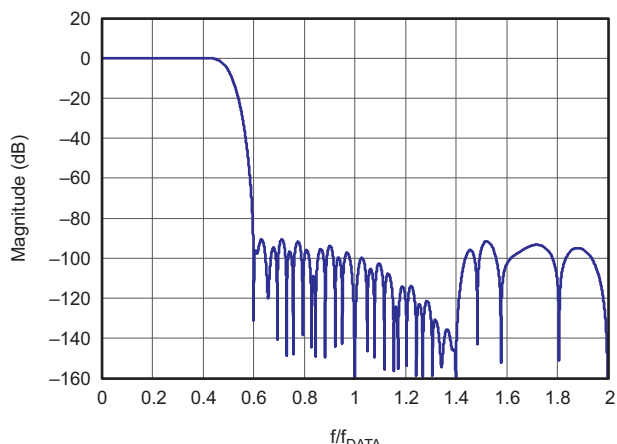

Figure 13. 4x Interpolation Composite Response

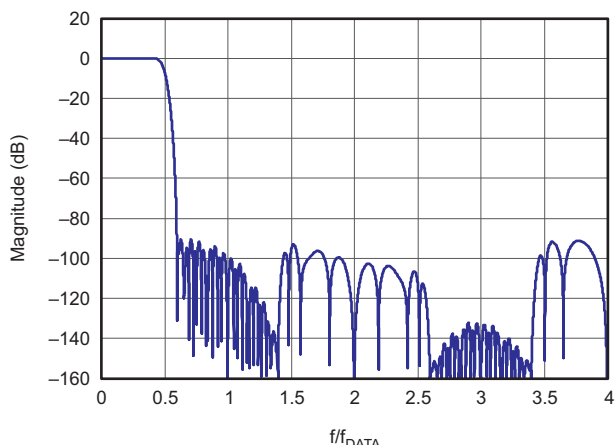

Figure 14. 8x Interpolation Composite Response

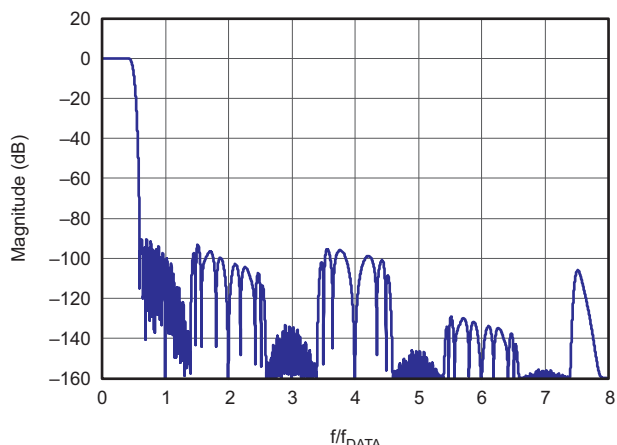

Figure 15. 16x Interpolation Composite Response

PRODUCT PREVIEW

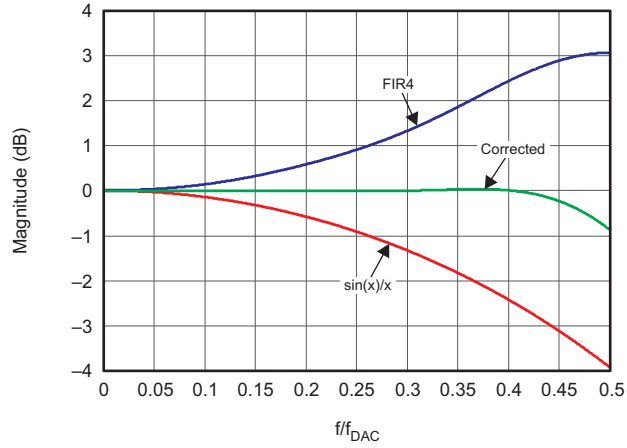

Figure 16. Magnitude Spectrum for Inverse Sinc Filter G056

PRODUCT PREVIEW

Table 17. FIR Filter Coefficients

2x Interpolating Half-band Filters								Non-Interpolating Inverse-SINC Filter	
FIR0		FIR1		FIR2		FIR3		FIR4	
59 Taps		23 Taps		11 Taps		11 Taps		9 Taps	
6	6	-12	-12	29	29	3	3	1	1
0	0	0	0	0	0	0	0	-4	-4
-19	-19	84	84	-214	-214	-25	-25	13	13
0	0	0	0	0	0	0	0	-50	-50
47	47	-336	-336	1209	1209	150	150	592 ⁽¹⁾	
0	0	0	0	2048 ⁽¹⁾		256 ⁽¹⁾			
-100	-100	1006	1006						
0	0	0	0						
192	192	-2691	-2691						
0	0	0	0						
-342	-342	10141	10141						
0	0	16384 ⁽¹⁾							
572	572								
0	0								
-914	-914								
0	0								
1409	1409								
0	0								
-2119	-2119								
0	0								
3152	3152								
0	0								
-4729	-4729								
0	0								
7420	7420								
0	0								
-13334	-13334								
0	0								
41527	41527								
65536 ⁽¹⁾									

(1) CENTER TAPS ARE HIGHLIGHTED IN BOLD

FULL COMPLEX MIXER

The DAC37J82/DAC38J82 has one full complex mixer (FMIX) blocks with Numerically Controlled Oscillators (NCO) that enables flexible frequency placement without imposing additional limitations in the signal bandwidth. The NCO has 48-bit frequency registers *mem_phaseaddab* (47:0) and 16-bit phase registers *mem_phaseoffsetab* (15:0) that generate the sine and cosine terms for the complex mixing. The NCO block diagram is shown in [Figure 17](#).

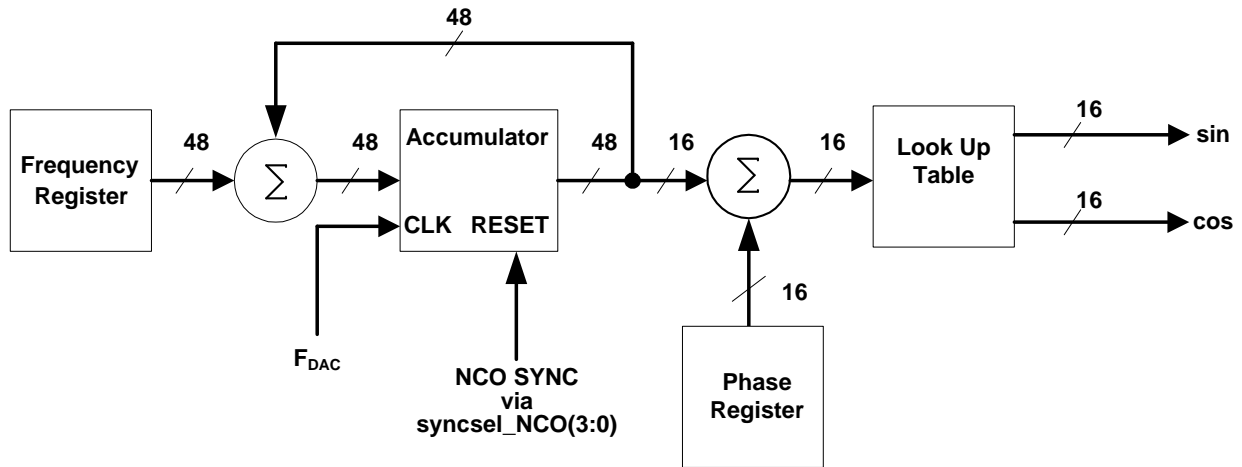

Figure 17. NCO Block Diagram

Synchronization of the NCOs occurs by resetting the NCO accumulators to zero. The synchronization source is selected by *mem_syncsel_NCO* (3:0) in *config31*. The frequency word in the *mem_phaseaddab* (47:0) registers is added to the accumulators every clock cycle, f_{DAC} . The output frequency of the NCO is

$$f_{NCO} = \frac{freq \times f_{NCO_CLK}}{2^{48}}$$

Treating the two complex channels in the DAC37J82/DAC38J82 as complex vectors of the form $I + jQ$, the output of FMIX $I_{OUT}(t)$ and $Q_{OUT}(t)$ is

$$I_{OUT}(t) = (I_{IN}(t)\cos(2\pi f_{NCO}t + \delta) - Q_{IN}(t)\sin(2\pi f_{NCO}t + \delta)) \times 2^{(mixer_gain - 1)}$$

$$Q_{OUT}(t) = (I_{IN}(t)\sin(2\pi f_{NCO}t + \delta) + Q_{IN}(t)\cos(2\pi f_{NCO}t + \delta)) \times 2^{(mixer_gain - 1)}$$

where t is the time since the last resetting of the NCO accumulator, δ is the phase offset value and *mixer_gain* is either 0 or 1. δ is given by:

$$\delta = 2\pi \times phase_offsetAB (15:0)/2^{16}$$

A block diagram of the mixer is shown in Figure 18. The complex mixer can be used as a digital quadrature modulator with a real output simply by only using the I_{OUT} branch and ignoring the Q_{OUT} branch.

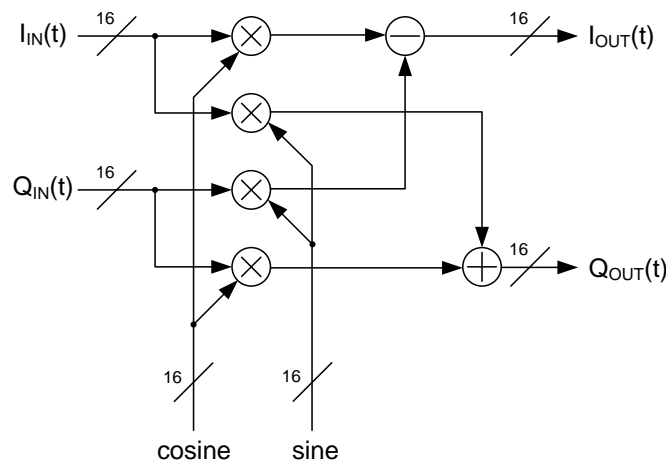

Figure 18. Complex Mixer Block Diagram

The maximum output amplitude of FMIX occurs if $I_{IN}(t)$ and $Q_{IN}(t)$ are simultaneously full scale amplitude and the sine and cosine arguments are equal to $2\pi \times f_{NCO}t + \delta (2N-1) \times \pi/4$ ($N = 1, 2, \dots$).

With **mem_mixer_gain** = 0 in *config2*, the gain through FMIX is $\sqrt{2}/2$ or –3 dB. This loss in signal power is in most cases undesirable, and it is recommended that the gain function of the QMC block be used to increase the signal by 3 dB to compensate. With **mem_mixer_gain** = 1, the gain through FMIX is $\sqrt{2}$ or +3 dB, which can cause clipping of the signal if $I_{IN}(t)$ and $Q_{IN}(t)$ are simultaneously near full scale amplitude and should therefore be used with caution.

COARSE MIXER

In addition to the full complex mixers the DAC37J82/DAC38J82 also has a coarse mixer block capable of shifting the input signal spectrum by the fixed mixing frequencies $\pm n \times f_s/8$. Using the coarse mixer instead of the full mixers will result in lower power consumption.

Treating the two complex channels as complex vectors of the form $I(t) + j Q(t)$, the outputs of the coarse mixer, $I_{OUT}(t)$ and $Q_{OUT}(t)$ are equivalent to:

$$I_{OUT}(t) = I(t)\cos(2\pi f_{CMIX}t) - Q(t)\sin(2\pi f_{CMIX}t)$$

$$Q_{OUT}(t) = I(t)\sin(2\pi f_{CMIX}t) + Q(t)\cos(2\pi f_{CMIX}t)$$

where f_{CMIX} is the fixed mixing frequency selected by **mem_cmix**=(*mem_fs8*, *mem_fs4*, *mem_fs2*, *mem_fsm4*). The mixing combinations are described in [Table 17](#).

Table 18. Coarse Mixer Combinations

cmix(3:0)	Fs/8 Mixer cmix(3)	Fs/4 Mixer cmix(2)	Fs/2 Mixer cmix(1)	-Fs/4 Mixer cmix(0)	Mixing Mode
0000	Disabled	Disabled	Disabled	Disabled	No mixing
0001	Disabled	Disabled	Disabled	Enabled	–Fs/4
0010	Disabled	Disabled	Enabled	Disabled	Fs/2
0100	Disabled	Enabled	Disabled	Disabled	+Fs/4
1000	Enabled	Disabled	Disabled	Disabled	+Fs/8
1010	Enabled	Disabled	Enabled	Disabled	–3Fs/8
1100	Enabled	Enabled	Disabled	Disabled	+3Fs/8
1110	Enabled	Enabled	Enabled	Disabled	–Fs/8
All others	—	—	—	—	Not recommended

DITHERING

DAC37J82/DAC38J82 supports the addition of a band limited dither to the DAC output after the complex mixer. This feature is enabled by set **mem_dither_ena** to “1” and can be useful in reducing the high order harmonics. The generated dithering sequence can be optionally up-converted to an offset of $F_s/2$ by setting **mem_dither_mixer_ena** to “1”. The added dithering sequence has variable amplitude in 6 dB steps via **mem_dither_sra_sel**.

QUADRATURE MODULATION CORRECTION (QMC)

Gain and Phase Correction

The DAC37J82/DAC38J82 includes a Quadrature Modulator Correction (QMC) block. The QMC blocks provide a mean for changing the gain and phase of the complex signals to compensate for any I and Q imbalances present in an analog quadrature modulator. The block diagram for the QMC block is shown in [Figure 19](#). The QMC block contains 3 programmable parameters.

Registers **mem_qmc_gaina** (10:0) and **mem_qmc_gainb** (10:0) controls the I and Q path gains and is an 11-bit unsigned value with a range of 0 to 1.9990 and the default gain is 1.0000. The implied decimal point for the multiplication is between bit 9 and bit 10. The resolution allows suppression to > 65 dBc for a frequency independent IQ imbalance (the fine delay FIR block also contains gain control through the filter taps or inverse gain block that allows control with > 20 bits resolution, which can be used to improve the sideband suppression).

Register *mem_qmc_phaseab* (11:0) control the phase imbalance between I and Q and are a 12-bit values with a range of -0.5 to approximately 0.49975 . The QMC phase term is not a direct phase rotation but a constant that is multiplied by each "Q" sample then summed into the "I" sample path. This is an approximation of a true phase rotation in order to keep the implementation simple. The resolution of the phase term allows suppression to > 80 dBc for a frequency independent IQ imbalance.

LO feed-through can be minimized by adjusting the DAC offset feature described below.

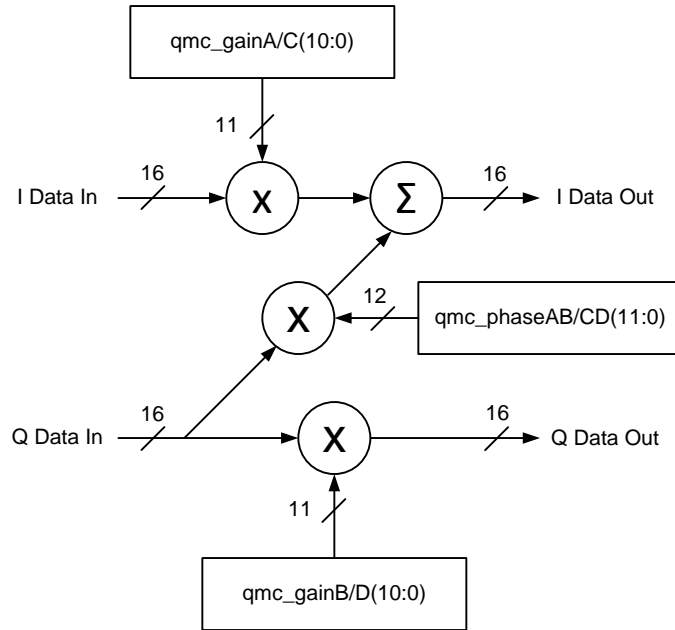

Figure 19. QMC Block Diagram

Offset Correction

Registers *mem_qmc_offseta* (12:0) and *mem_qmc_offsetb* (12:0) can be used to independently adjust the DC offsets of each channel. The offset values are represented in 2s-complement format with a range from -4096 to 4095 . The LSB resolution of the offset allows LO suppression to better than 90 dBFS.

The offset value adds a digital offset to the digital data before digital-to-analog conversion. Since the offset is added directly to the data it may be necessary to back off the signal to prevent saturation. Both data and offset values are LSB aligned.

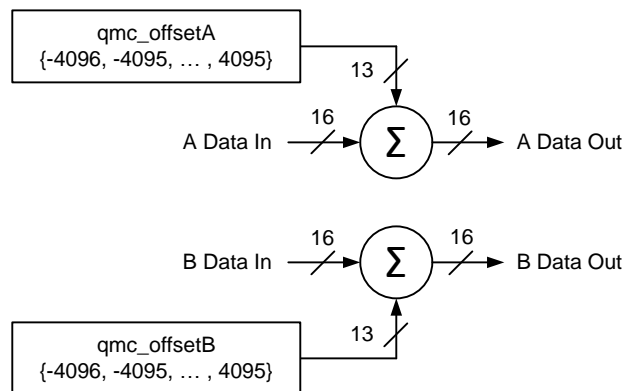

Figure 20. Digital Offset Block Diagram

GROUP DELAY CORRECTION BLOCK

A complex transmitter system typically is consisted of a DAC, reconstruction filter network, and I/Q modulator. Besides the gain and phase mismatch contribution, there could also be timing mismatch contribution from each components. For instance, the timing mismatch could come from the PCB trace length variation between the I and Q channels and the group delay variation from the reconstruction filter. This timing mismatch in the complex transmitter system creates phase mismatch that varies linearly with respect to frequency. To compensate for the I/Q imbalances due to this mismatch, the DAC37J82/DAC38J82 has group delay correction block for each DAC channel.

DAC38J82/DAC37J82 incorporates 2 FIR filters for small fractional group delay and 4 FIR filters for large fractional group delay. The input data to this block consists of 2, complex data (I/Q) channels i.e., 4 buses of 16-bit data. Control bits from configuration registers select the data path for all inputs through this block. Each input can either go through the small fractional delay filter (while its conjugate part goes through the matched delay line) or bypass the small fractional delay sub-block completely (matched delay line is bypassed for the conjugate part). The input to the large fractional delay F can either come from the output of small fractional delay sub-block or the original input to the block. The large fractional delay sub-block can also be completely bypassed if desired.

DAC38J82/DAC37J82 also include an integer delay block following each large fractional group delay filter, which can further delay the DAC output by $[0-3] \times T_{dac}$. Both A&B channels share the same control signal *mem_output_delayab*, which means that both channels have the same integer delay.

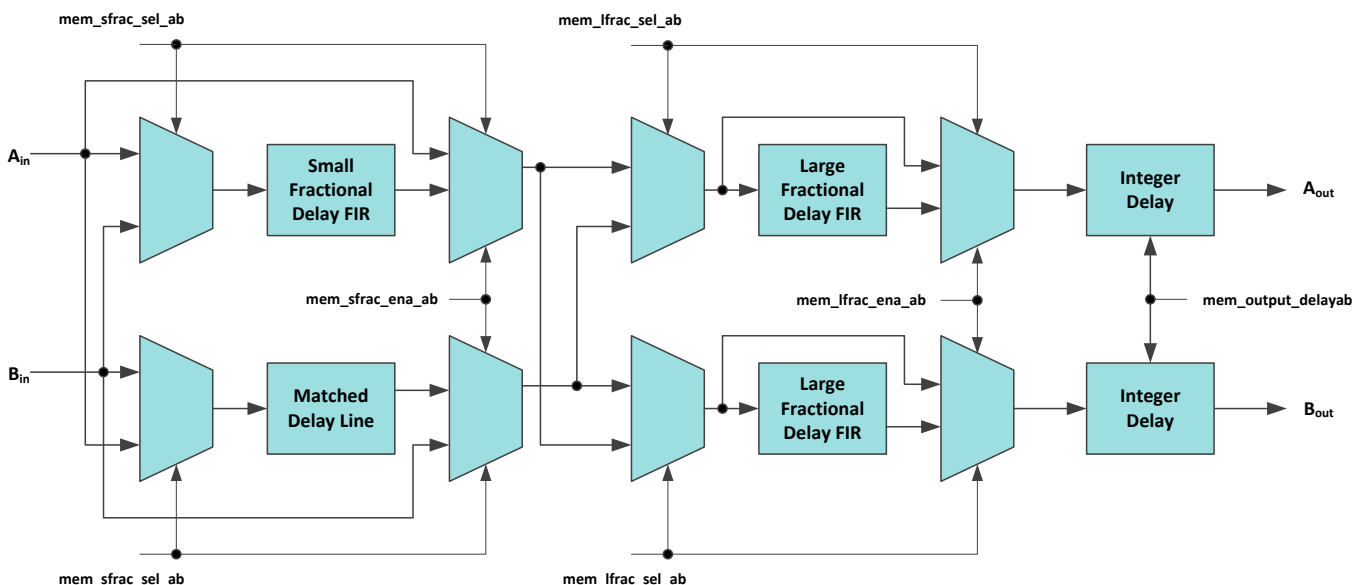

Figure 21. Diagram of Group Delay Correction

Fine Fractional Delay FIR Filter

The coefficients of the FIR filters for small fractional delay are programmable to user defined values which allows users to implement their own filter transfer functions. Filter designs supporting group delay variation in the range $[0.002 \ 0.198] \times T_{dac}$, where T is the time period of DAC Clock, is listed in Table 19. The bit widths of all coefficients are fixed, which puts limits on the range of values each coefficient can acquire.

Table 19. Small Fractional Delay FIR Coefficient Range

COEFFICIENT	RANGE
C0	[-2,1]
C1	[-16,15]
C2	[-128,127]
C3	[-512,511]
C4	[-262144,262143]
C5	[-512,511]

Table 19. Small Fractional Delay FIR Coefficient Range (continued)

COEFFICIENT	RANGE
C6	[-256,255]
C7	[-64,63]
C8	[-16,15]
C9	[-2,1]

Table 20. Example Coefficient Sets for the Small Fractional Delay

C0	C1	C2	C3	C4	C5	C6	C7	C8	C9	InvGain Numerator	Delay [Tdac]
1	-12	64	-273	195897	393	-137	43	-9	1	5479	0.002
1	-12	64	-272	97872	393	-137	43	-9	1	10963	0.004
1	-12	64	-271	65138	394	-137	43	-9	1	16465	0.006
1	-12	64	-270	48873	395	-137	43	-9	1	21936	0.008
1	-12	64	-270	39068	395	-137	43	-9	1	27431	0.01
1	-12	64	-269	32555	396	-137	43	-9	1	32904	0.012
1	-12	63	-269	27892	396	-137	43	-9	1	38390	0.014
1	-12	63	-268	24387	397	-138	43	-9	1	43889	0.016
1	-12	63	-267	21666	398	-138	43	-9	1	49377	0.018
1	-12	63	-267	19496	398	-138	43	-9	1	54850	0.02
1	-12	63	-266	17722	399	-138	43	-9	1	60309	0.022
1	-12	63	-265	16235	400	-138	43	-9	1	65797	0.024
1	-12	63	-265	14981	400	-138	43	-9	1	71274	0.026
1	-12	63	-264	13907	401	-138	43	-9	1	76734	0.028
1	-12	63	-263	12973	402	-138	43	-9	1	82210	0.03
1	-12	63	-263	12159	402	-138	43	-9	1	87674	0.032
1	-12	63	-262	11439	403	-138	43	-9	1	93134	0.034
1	-12	63	-262	10798	404	-138	43	-9	1	98608	0.036
1	-12	62	-261	10227	404	-139	43	-9	1	104075	0.038
1	-12	62	-261	9714	405	-139	43	-9	1	109510	0.04
1	-12	62	-260	9246	406	-139	43	-9	1	114974	0.042
1	-12	62	-259	8823	406	-139	43	-9	1	120415	0.044
1	-12	62	-259	8435	407	-139	43	-9	1	125878	0.046
1	-12	62	-258	8080	408	-139	43	-9	1	131312	0.048
1	-12	62	-257	7754	408	-139	43	-9	1	136748	0.05
1	-12	62	-257	7454	409	-139	43	-9	1	142161	0.052
1	-12	62	-256	7174	410	-139	43	-9	1	147593	0.054
1	-12	62	-256	6916	411	-139	43	-9	1	152998	0.056
1	-12	62	-255	6675	411	-139	43	-9	1	158416	0.058
1	-12	62	-255	6450	412	-139	43	-9	1	163830	0.06
1	-12	61	-254	6239	413	-140	43	-9	1	169280	0.062
1	-12	61	-253	6042	413	-140	43	-9	1	174677	0.064
1	-12	61	-253	5856	414	-140	43	-9	1	180098	0.066
1	-12	61	-252	5683	415	-140	43	-9	1	185416	0.068
1	-12	61	-252	5518	416	-140	43	-9	1	190820	0.07
1	-12	61	-251	5363	416	-140	43	-9	1	196189	0.072
1	-12	61	-251	5215	417	-140	43	-9	1	201604	0.074
1	-12	61	-250	5076	418	-140	43	-9	1	206927	0.076

PRODUCT PREVIEW

Table 20. Example Coefficient Sets for the Small Fractional Delay (continued)

C0	C1	C2	C3	C4	C5	C6	C7	C8	C9	InvGain Numerator	Delay [Tdac]
1	-12	61	-249	4944	419	-140	43	-9	1	212244	0.078
1	-12	61	-249	4819	419	-140	43	-9	1	217621	0.08
1	-12	61	-248	4700	420	-140	43	-9	1	222907	0.082
1	-12	61	-248	4586	421	-141	43	-9	1	228310	0.084
1	-12	60	-247	4477	422	-141	43	-9	1	233676	0.086
1	-12	60	-247	4375	422	-141	43	-9	1	238981	0.088
1	-12	60	-246	4275	423	-141	43	-9	1	244310	0.09
1	-12	60	-246	4181	424	-141	44	-9	1	249533	0.092
1	-12	60	-245	4090	425	-141	44	-9	1	254803	0.094
1	-12	60	-245	4003	425	-141	44	-9	1	260175	0.096
1	-12	60	-244	3920	426	-141	44	-9	1	265384	0.098
1	-12	60	-243	3840	427	-141	44	-9	1	270600	0.1
1	-12	60	-243	3763	428	-141	44	-9	1	275884	0.102
1	-12	60	-242	3690	429	-141	44	-9	1	281011	0.104
1	-12	60	-242	3619	429	-142	44	-9	1	286408	0.106
1	-12	60	-241	3550	430	-142	44	-9	1	291619	0.108
1	-12	60	-241	3484	431	-142	44	-9	1	296860	0.11
1	-12	59	-240	3421	432	-142	44	-9	1	302037	0.112
1	-12	59	-240	3360	433	-142	44	-9	1	307222	0.114
1	-12	59	-239	3300	433	-142	44	-9	1	312498	0.116
1	-12	59	-239	3243	434	-142	44	-9	1	317675	0.118
1	-12	59	-238	3188	435	-142	44	-9	1	322736	0.12
1	-12	59	-238	3134	436	-142	44	-9	1	327960	0.122
1	-12	59	-237	3082	437	-142	44	-9	1	333046	0.124
1	-12	59	-237	3033	438	-143	44	-9	1	338186	0.126
1	-12	59	-236	2984	438	-143	44	-9	1	343378	0.128
1	-11	59	-236	2937	439	-143	44	-9	1	348391	0.13
1	-11	59	-235	2891	440	-143	44	-9	1	353437	0.132
1	-11	59	-235	2847	441	-143	44	-9	1	358511	0.134
1	-11	58	-234	2804	442	-143	44	-9	1	363611	0.136
1	-11	58	-234	2762	443	-143	44	-9	1	368730	0.138
1	-11	58	-233	2722	443	-143	44	-9	1	373735	0.14
1	-11	58	-233	2682	444	-143	44	-9	1	378879	0.142
1	-11	58	-232	2644	445	-143	44	-9	1	383753	0.144
1	-11	58	-232	2607	446	-143	44	-9	1	388755	0.146
1	-11	58	-231	2570	447	-144	44	-9	1	393889	0.148
1	-11	58	-231	2535	448	-144	44	-9	1	398864	0.15
1	-11	58	-230	2501	449	-144	44	-9	1	403662	0.152
1	-11	58	-230	2467	449	-144	44	-9	1	408889	0.154
1	-11	58	-229	2435	450	-144	44	-9	1	413614	0.156
1	-11	58	-229	2403	451	-144	44	-9	1	418613	0.158
1	-11	58	-228	2372	452	-144	44	-9	1	423400	0.16
1	-11	57	-228	2342	453	-144	44	-9	1	428468	0.162
1	-11	57	-227	2313	454	-144	44	-9	1	433135	0.164
1	-11	57	-227	2284	455	-144	44	-9	1	438083	0.166
1	-11	57	-226	2256	456	-145	44	-9	1	442963	0.168

Table 20. Example Coefficient Sets for the Small Fractional Delay (continued)

C0	C1	C2	C3	C4	C5	C6	C7	C8	C9	InvGain Numerator	Delay [Tdac]
1	-11	57	-226	2228	457	-145	44	-9	1	447952	0.17
1	-11	57	-225	2202	458	-145	44	-9	1	452483	0.172
1	-11	57	-225	2175	459	-145	44	-9	1	457495	0.174
1	-11	57	-224	2150	459	-145	44	-9	1	462222	0.176
1	-11	57	-224	2125	460	-145	44	-9	1	467047	0.178
1	-11	57	-223	2100	461	-145	44	-9	1	471767	0.18
1	-11	57	-223	2076	462	-145	44	-9	1	476583	0.182
1	-11	57	-223	2053	463	-145	44	-9	1	481283	0.184
1	-11	57	-222	2030	464	-145	44	-9	1	485856	0.186
1	-11	57	-222	2008	465	-146	44	-9	1	490741	0.188
1	-11	56	-221	1986	466	-146	44	-9	1	495497	0.19
1	-11	56	-221	1964	467	-146	44	-9	1	500346	0.192
1	-11	56	-220	1943	468	-146	44	-9	1	504815	0.194
1	-11	56	-220	1923	469	-146	44	-9	1	509365	0.196
1	-11	56	-219	1903	470	-146	44	-9	1	513752	0.198

Coarse Fractional Delay FIR Filter

The coefficients of FIR filters for large fractional delay can only be chosen from a predefined set of values. Each set of values produces a specific delay with a step of 1/8xTdac. The value of coefficients as well as their resultant fractional delay is provided in [Table 20](#).

Table 21. Available Coefficient Sets for Large Fractional Delay FIR

mem_lfras_coef sel_x	C0	C1	C2	C3	C4	C5	C6	C7	InvGain Numerator	Delay [Tdac]
000	-1	9	-39	532	76	-24	7	-1	7503	0.1250
001	-1	8	-35	259	87	-25	7	-1	14028	0.2500
010	-1	7	-31	168	101	-26	7	-1	18725	0.3750
011	-1	7	-27	122	122	-27	7	-1	20764	0.5000
100	—	—	—	—	—	—	—	—	—	—
101	-1	7	-1	7	-1	7	-1	7	-1	7
110	-1	7	-25	87	259	-35	8	-1	14028	0.7500
111	-1	7	-24	76	532	-39	9	-1	7503	0.8750

OUTPUT MULTIPLEXER

The DAC37J82/DAC38J82 includes an output multiplexer before the digital to analog converters that allows any signal channel A-B to be routed to any DAC A-D. See *mem_pathx_out_sel* for details on how to configure the cross-bar switches. This output multiplexer gives great flexibility in the board layout by providing four possible output routing for the internal two signal paths.

POWER MEASUREMENT AND POWER AMPLIFIER PROTECTION

DAC37J82/DAC38J82 provides an optional mechanism to protect the Power Amplifier (PA) in cases when the signal power shows some abnormality. For example, if the data clock is lost, the FIFO would automatically generate a single tone signal, which causes abnormally high average power and could be dangerous to the PA. In the PA protection mechanism, the signal power is monitored by maintaining an sliding window accumulation of last N samples. N is selectable to be 64 or 128 based on the setting of *mem_pap_dlylen_sel*. The average

amplitude of input signal is computed by dividing accumulated value by the number of samples in the delay-line (N). The result is then compared against a threshold (*mem_pap_vth*). If the threshold is violated, the delayed input signal is divided by a value chosen by *mem_pap_gain*, to form a scaled down version of the input signal. Since PAP output derives from a delay-line, there is deterministic latency of at least N cycles from the block input to block output. The PA protection is enabled by setting the *mem_pap_ena* bit to “1”.

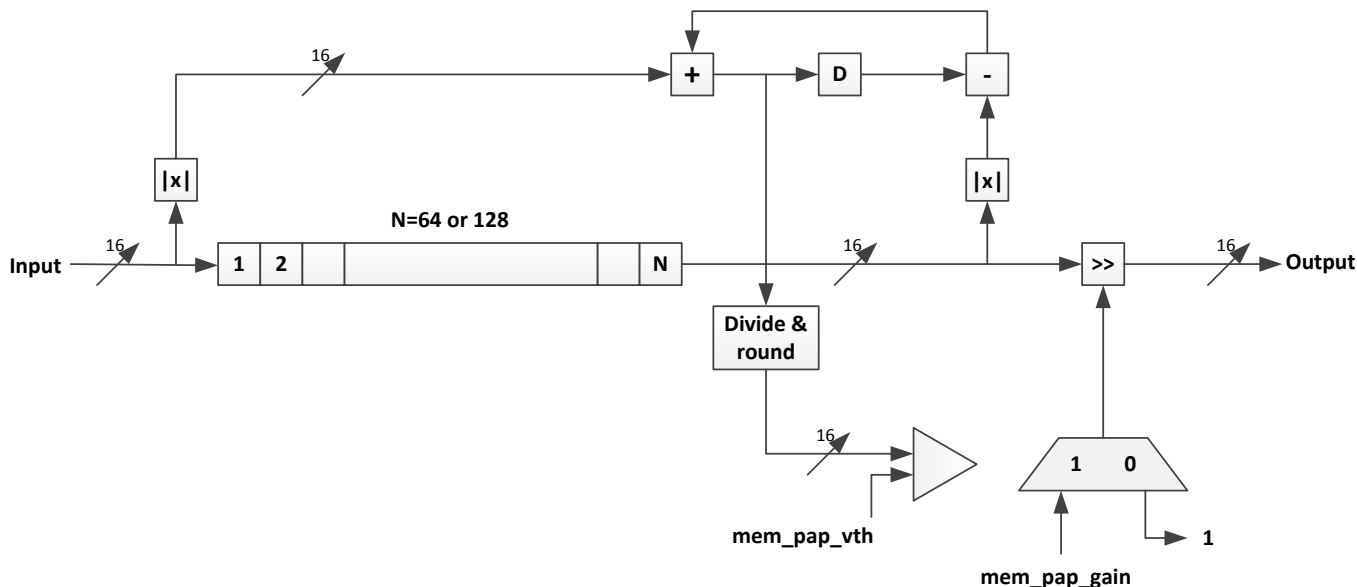

Figure 22. Diagram of Power Measurement and PA Protection Mechanism

SERDES TEST MODES

DAC37J82/DAC38J82 supports a number of basic pattern generation and verification of SerDes via SIF. Three pseudo random bit stream (PRBS) sequences are available, along with an alternating 0/1 pattern and a 20-bit user-defined sequence. The 2^7-1 , $2^{23}-1$ or $2^{31}-1$ sequences implemented can often be found programmed into standard test equipment, such as a Bit Error Rate Tester (BERT). Pattern generation and verification selection is via the **TESTPATT** fields of *mem_rw_cfg_rx0*[14:12], as shown in Table 21.

Table 22. SerDes Test Pattern Selection

TESTPATT	EFFECT
000	Test mode disabled.
001	Alternating 0/1 Pattern. An alternating 0/1 pattern with a period of 2UI.
010	Generate or Verify 2^7-1 PRBS. Uses a 7-bit LFSR with feedback polynomial $x^7 + x^6 + 1$.
011	Generate or Verify $2^{23}-1$ PRBS. Uses an ITU O.150 conformant 23-bit LFSR with feedback polynomial $x^{23} + x^{18} + 1$.
100	Generate or Verify $2^{31}-1$ PRBS. Uses an ITU O.150 conformant 31-bit LFSR with feedback polynomial $x^{31} + x^{28} + 1$.
101	User-defined 20-bit pattern. Uses the USR PATT IEEE 1500 Tuning instruction field to specify the pattern. The default value is 0x666666.
11x	Reserved

Pattern verification compares the output of the serial to parallel converter with an expected pattern. When there is a mismatch, the **TESTFAIL** bit is driven high, which can be programmed to come out the ALARM pin by setting *mem_dtest*[3:0] to “0011”.

DAC37J82/DAC38J82 also provide a number of advanced diagnostic capabilities controlled by the IEEE 1500 interface. These are:

- Accumulation of pattern verification errors;
- The ability to map out the width and height of the receive eye, known as Eye Scan;
- Real-time monitoring of internal voltages and currents;

The SerDes blocks support the following IEEE1500 instructions:

Table 23. IEEE1500 Instruction for SerDes Receivers

INSTRUCTION	Opcode	DESCRIPTION
ws_bypass	0x00	Bypass. Selects a 1-bit bypass data register. Use when accessing other macros on the same IEEE1500 scan chain.
ws_cfg	0x35	Configuration. Write protection options for other instructions.
ws_core	0x30	Core. Fields also accessible via dedicated core-side ports.
ws_tuning	0x31	Tuning. Fields for fine tuning macro performance.
ws_debug	0x32	Debug. Fields for advanced control, manufacturing test, silicon characterization and debug
ws_unshadowed	0x34	Unshadowed. Fields for silicon characterization.
ws_char	0x33	Char. Fields used for eye scan.

The data for each SerDes instruction is formed by chaining together sub-components called head, body (receiver or transmitter) and tail. DAC37J82/DAC38J82 uses two SerDes receiver blocks R0 and R1, each of which contains 4 receive lanes (channels), the data for each IEEE1500 instruction is formed by chaining **{head, receive lane 0, receive lane 1, receive lane 2, receive lane 3, tail}**. A description of bits in head, body and tail for each instruction is given as follows:

NOTE

All multi-bit signals in each chain are packed with bits reversed e.g. mpy[7:0] in ws_core head subchain is packed as {retime, enpll, **mpy[0:7]**, vrange, **lb[0:1]**}. All DATA REGISTER READS from RinceWind Block R0 should read 1 bit more than the desired number of bits and discard the first bit received on TDO e.g., to read 40-bit data from R0 block, 41 bits should be read off from TDO and the first bit received should be discarded. Similarly, any data written to RinceWind Block R0 Data Registers should be prefixed with an extra 0.

Table 24. ws_cfg Chain

FIELD	DESCRIPTION
HEAD (STARTING FROM THE MSB OF CHAIN)	
retime	No function.
core_we	Core chain write enable.
RECEIVER (FOR EACH LANE 0,1,2,3)	
core_we	Core chain write enable.
tuning_we	Tuning chain write enable.
debug_we	Reserved.
char_we	Char chain write enable.
unshadowed_we	Reserved.
TAIL (ENDING WITH THE LSB OF CHAIN)	
core_we	Core chain write enable.
tuning_we	Tuning chain write enable.
debug_we	Reserved.
retime	No function.
CHAIN LENGTH = 26 BITS	

Table 25. ws_core Chain

FIELD	DESCRIPTION
HEAD (STARTING FROM THE MSB OF CHAIN)	
retime	No function.
enpll	PLL enable.
mpy[7:0]	PLL multiply.
vrange	VCO range.

Table 25. ws_core Chain (continued)

FIELD	DESCRIPTION
endivclk	Enable DIVCLK output
lb[1:0]	Loop bandwidth
RECEIVER (FOR EACH LANE 0,1,2,3)	
enrx	Receiver enable.
sleeprx	Receiver sleep mode.
buswidth[2:0]	Bus width.
rate[1:0]	Operating rate.
invpair	Invert polarity.
term[2:0]	Termination.
align[1:0]	Symbol alignment.
los[2:0]	Loss of signal enable.
cdr[2:0]	Clock/data recovery.
eq[2:0]	Equalizer.
Eqhld	Equalizer hold.
Enoc	Offset compensation.
loopback[1:0]	Loopback.
bsinrxp	Boundary scan initialization.
bsinrxn	Boundary scan initialization.
reserved	Reserved.
testpatt[2:0]	Testpattern selection.
testfail	Test failure (real time).
losdtct	Loss of signal detected (real time).
Bsrxp	Boundary scan data.
Bsrxn	Boundary scan data.
ocip	Offset compensation in progress.
eqover	Received signal over equalized.
equnder	Received signal under equalized.
losdtct	Loss of signal detected (sticky).
sync	Re-alignment done, or aligned comma output (sticky)
Retime	No function.
TAIL (ENDING WITH THE LSB OF CHAIN)	
clkbyp[1:0]	Clock bypass.
sleeppll	PLL sleep mode.
reserved	Reserved.
lock	PLL lock (real time).
bsinitclk	Boundary scan initialization clock.
enbstx	Enable Tx boundary scan.
enbsrx	Enable Rx boundary scan.
enbspt	Rx pulse boundary scan.
reserved	Reserved.
nearlock	PLL near to lock.
unlock	PLL lock (sticky).
cfg ovr	Configuration over-ride.
retime	No function.
CHAIN LENGTH = 196 BITS	

Table 26. ws_ tuning Chain

FIELD	DESCRIPTION
HEAD (STARTING FROM THE MSB OF CHAIN)	
retime	No function.
RECEIVER (FOR EACH LANE 0,1,2,3)	
patterthr[2:0]	Resync error threshold.
patt timer	PRBS Timer.
rxdsel[3:0]	Status select.
encor	Enable clear-on-read for error counter.
eqzero[4:0]	EQZ OVRi Equalizer zero.
eqz ovr	Equalizer zero over-ride.
eqlevel[15:0]	EQ OVRi Equalizer gain observe or set.
eq ovr	Equalizer over-ride.
eqboost[1:0]	Equalizer gain boost.
rxasel[2:0]	Selects amux output.
TAIL (ENDING WITH THE LSB OF CHAIN)	
asel[3:0]	Selects amux output.
usr patt[19:0]	User-defined test pattern.
retime	No function.
CHAIN LENGTH = 174 BITS	

Table 27. ws_ char Chain

FIELD	DESCRIPTION
HEAD (STARTING FROM THE MSB OF CHAIN)	
retime	No function.
RECEIVER (FOR EACH LANE 0,1,2,3)	
testfail	Test failure (sticky).
ecount[11:0]	Error counter.
esword[7:0]	Eye scan word masking.
es[3:0]	Eye scan.
espo[6:0]	Eye scan phase offset.
es bit select[4:0]	Eye scan compare bit select.
esvo[5:0]	Eye scan voltage offset.
esvo ovr	Eye scan voltage offset override.
eslen[1:0]	Eye scan run length.
esrun	Eye scan run.
esdone	Eye scan done.
TAIL (ENDING WITH THE LSB OF CHAIN)	
retime	No function.
CHAIN LENGTH = 194 BITS	

ERROR COUNTER

All receive channels include a 12-bit counter for accumulating pattern verification errors. This counter is accessible via the ECOUNT IEEE1500 Char field. It is an essential part of the eye scan capability (see next section), though can be used independently of this.

The counter increments once for every cycle that the TESTFAIL bit is detected. The counter will not increment when at its maximum value (i.e., all 1s). When an IEEE1500 capture is performed, the count value is loaded into the ECOUNT scan elements (so that it can be scanned out), and the counter is then reset, provided ENCOR is set high.

ECOUNT can be used to get a measure of the bit error rate. However, as the error rate increases, it will become less accurate due to limitations of the pattern verification capabilities. Specifically, the pattern verifier checks multiple bits in parallel (as determined by the Rx bus width), and it is not possible to distinguish between 1 or more errors in this.

EYE SCAN

All receive channels provide features which facilitate mapping the received data eye or extracting a symbol response. A number of fields accessible via the IEEE1500 Char scan chain allow the required low level data to be gathered. The process of transforming this data into a map of the eye or a symbol response must then be performed externally, typically in software.

The basic principle used is as follows:

- Enable dedicated eye scan input samplers, and generate an error when the value sampled differs from the normal data sample;
- Apply a voltage offset to the dedicated eye scan input samplers, to effectively reduce their sensitivity;
- Apply a phase offset to adjust the point in the eye that the dedicated eye scan data samples are taken;
- Reset the error counter to remove any false errors accumulated as a result of the voltage or phase offset adjustments;
- Run in this state for a period of time, periodically checking to see if any errors have occurred;
- Change voltage and/or phase offset, and repeat.

Alternatively, the algorithm can be configured to optimize the voltage offset at a specified phase offset, over a specified time interval.

Eye scan can be used in both synchronous and asynchronous systems, whilst receiving normal data traffic. The IEEE1500 Char fields used to directly control eye scan and symbol response extraction are ES, ESWORD, ES BIT SELECT, ELEN, ESPO, ESVO, ESVO OVR, ESRUN and ESDONE, see [Table 26](#). Eye scan errors are accumulated in ECOUNT.

The required eyescan mode is selected via the ES field, as shown in [Table 27](#). When enabled, only data from the bit position within the 20-bit word specified via ES BIT SELECT is analyzed. In other words, only eye scan errors associated with data output at this bit position will accumulate in ECOUNT. The maximum legal ES BIT SELECT is 10011.

Table 28. Eye Scan Mode Selection

ES[3:0]	EFFECT
0000	Disabled. Eye scan is disabled.
0x01	Compare. Counts mismatches between the normal sample and the eyescan sample if ES[2] = 0, and matches otherwise.
0x10	Compare zeros. As ES = 0x01, but only analyses zeros, and ignores ones.
0x11	Compare ones. As ES = 0x01, but only analyses ones, and ignores zeroes
0100	Count ones. Increments ECOUNT when the eyescan sample is a 1.
1x00	Average. Adjusts ESVO to the average eye opening over the time interval specified by ELEN. Analyses zeroes when ES[2] = 0, and ones when ES[2] = 1.
1001 1110	Outer. Adjusts ESVO to the outer eye opening (i.e. lowest voltage zero, highest voltage 1) over the time interval specified by ELEN. 1001 analyses zeroes, 1110 analyses ones.
1010 1101	Inner. Adjusts ESVO to the inner eye opening (i.e. highest voltage zero, lowest voltage 1) over the time interval specified by ELEN. 1010 analyses zeroes, 1101 analyses ones.
1x11	Timed Compare. As ES = 001x, but analyses over the time interval specified by ELEN. Analyses zeroes when ES[2] = 0, and ones when ES[2] = 1.

When ES[3] = 0, the selected analysis runs continuously. However, when ES[3] = 1, only the number of qualified samples specified by ELEN, as shown in [Table 28](#). In this case, analysis is started by writing a 1 to ESRUN (it is not necessary to set it back to 0). When analysis completes, ESDONE will be set to 1.

Table 29. Eye Scan Run Length

ESLen	Number of Samples Analyzed
00	127
01	1023
10	8095
11	65535

When ESVO OVR = 1, the ESVO field determines the amount of offset voltage that is applied to the eye scan data samplers associated with rxpi and rxni. The amount of offset is variable between 0 and 300mV in increments of ~10mV, as shown in [Table 29](#). When ES[3] = 1, ESVO OVR must be 0 to allow the optimized voltage offset to be read back via ESVO.

Table 30. Eye Scan Voltage Offset

ESVO	Offset(mV)
100000	-310
..	..
111110	-20
111111	-10
000000	0
000001	10
000010	20
..	..
011111	300

The phase position of the samplers associated with rxpi and rxni, is controlled to a precision of 1/32UI. When ES is not 00, the phase position can be adjusted forwards or backwards by more than one UI using the ESPO field, as shown in [Figure 30](#). In normal use, the range should be limited to ±0.5UI (+15 to -16 phase steps).

Table 31. Eye Scan Phase Offset

ESPO	Offset(1/32UI)
011111	+63
..	..
000001	+1
000000	0
111111	-1
..	..
100000	-64

JESD204B PATTERN TEST

DAC37J82/DAC38J82 supports the following test patterns for JESD204B:

- Link layer test pattern
 - Verify repeating /D.21.5/ high freq. pattern for random jitter (RJ)
 - Verify repeating /K.28.5/ mixed freq pattern for deterministic jitter (DJ)
 - Verify repeating initial lane alignment (ILA) sequence
 - RPAT, JSPAT or JTSPAT pattern can be verified using errors counter of 8b/10b errors produced over an amount of time to get an estimate of BER.
- Transport layer test pattern: implements a short transport layer pattern check based on $F = 1, 2, 4$ or 8 . The short test pattern has a duration of one frame period and is repeated continuously for the duration of the test. Refer to JESD204B standard section 5.1.6 for more details.
 - $F = 1$: Looks for a constant 0xF1.
 - $F = 2$: Each frame should consist of 0xF1, 0xE2
 - $F = 4$: Looks for a constant 0xF1, 0xE2, 0xD3, 0xC4
 - $F = 8$: Each frame should consist of 0xF1, 0xE2, 0xD3, 0xC4, 0xB5, 0xA6, 0x97, 0x81

Users can select to output the internal data (ex, the 8b/10 decoder output, comma alignment output, lane alignment output, frame alignment output, descrambler output, etc) of a JESD link for test purpose. See *mem_jesd_testbus_sel* for configuration details.

TEMPERATURE SENSOR

The DAC37J82/DAC38J82 incorporates a temperature sensor block which monitors the temperature by measuring the voltage across 2 transistors. The voltage is converted to an 8-bit digital word using a successive-approximation (SAR) analog to digital conversion process. The result is scaled, limited and formatted as a twos complement value representing the temperature in degrees Celsius.

The sampling is controlled by the serial interface signals SDENB and SCLK. If the temperature sensor is enabled (*mem_tsense_sleep* = "0" in register *config26*) a conversion takes place each time the serial port is written or read. The data is only read and sent out by the digital block when the temperature sensor is read in *memin_tempdata* in *config7*. The conversion uses the first eight clocks of the serial clock as the capture and conversion clock, the data is valid on the falling eighth SCLK. The data is then clocked out of the chip on the rising edge of the ninth SCLK. No other clocks to the chip are necessary for the temperature sensor operation. As a result the temperature sensor is enabled even when the device is in sleep mode.

In order for the process described above to operate properly, the serial port read from *config6* must be done with an SCLK period of at least 1 μ s. If this is not satisfied the temperature sensor accuracy is greatly reduced.

ALARM MONITORING

The DAC37J82/DAC38J82 includes a flexible set of alarm monitoring that can be used to alert of a possible malfunction scenario. All the alarm events can be accessed either through the SIP registers and/or through the ALARM pin. Once an alarm is set, the corresponding alarm bit in register *config7bd* must be reset through the serial interface to allow further testing. The set of alarms includes the following conditions:

- *JESD alarms*
 - multiframe alignment_error. Occurs when multiframe alignment fails.
 - frame alignment error. Occurs when multiframe alignment fails.
 - link configuration error. Occurs when there is wrong link configuration.
 - elastic buffer overflow. Occurs when bad RBD value is used.
 - elastic buffer match error. Occurs when the first non-/K/ doesn't match the programmed data.
 - code synchronization error.
 - 8b/10b not-in-table decode error.
 - 8b/10 disparity error.
 - alarm_from_shorttest. Occurs when fails the short pattern test.
- *SerDes alarms*
 - *memin_rw_losdct*. Occurs when there are loss of signal detect from SerDes lanes.

REFERENCE OPERATION

The DAC37J82/DAC38J82 uses a bandgap reference and control amplifier for biasing the full-scale output current. The full-scale output current is set by applying an external resistor R_{BIAS} to pin BIASJ. The bias current I_{BIAS} through resistor R_{BIAS} is defined by the on-chip bandgap reference voltage and control amplifier. The default full-scale output current equals 64 times this bias current and can thus be expressed as:

$$I_{OUT_{FS}} = 16 \times I_{BIAS} = 64 \times V_{EXTIO} / R_{BIAS}$$

The DAC37J82/DAC38J82 has a 4-bit coarse gain control *coarse_dac(3:0)* in the *configtbd* register. Using gain control, the $I_{OUT_{FS}}$ can be expressed as:

$$I_{OUT_{FS}} = (\text{coarse_dac} + 1) / 16 \times I_{BIAS} \times 64 = (\text{coarse_dac} + 1) / 16 \times V_{EXTIO} / R_{BIAS} \times 64$$

where V_{EXTIO} is the voltage at terminal EXTIO. The bandgap reference voltage delivers an accurate voltage of 0.9V. This reference is active when *extref_ena* = '0' in *configtbd*. An external decoupling capacitor C_{EXT} of 0.1 μ F should be connected externally to terminal EXTIO for compensation. The bandgap reference can additionally be used for external reference operation. In that case, an external buffer with high impedance input should be applied in order to limit the bandgap load current to a maximum of 100 nA. The internal reference can be disabled and overridden by an external reference by setting the *extref_ena* control bit. Capacitor C_{EXT} may hence be omitted. Terminal EXTIO thus serves as either input or output node.

The full-scale output current can be adjusted from 30 mA down to 10 mA by varying resistor R_{BIAS} or changing the externally applied reference voltage.

ANALOG OUTPUTS

The CMOS DACs consist of a segmented array of PMOS current sources, capable of sourcing a full-scale output current up to 30 mA. Differential current switches direct the current to either one of the complimentary output nodes IOU TP or IOU TN. Complimentary output currents enable differential operation, thus canceling out common mode noise sources (digital feed-through, on-chip and PCB noise), dc offsets, even order distortion components, and increasing signal output power by a factor of four.

The full-scale output current is set using external resistor R_{BIAS} in combination with an on-chip bandgap voltage reference source (+0.9 V) and control amplifier. Current I_{BIAS} through resistor R_{BIAS} is mirrored internally to provide a maximum full-scale output current equal to 16 times I_{BIAS} .

The relation between IOU TP and IOU TN can be expressed as:

$$I_{OUT_{FS}} = I_{OUTP} + I_{OUTN}$$

We will denote current flowing into a node as –current and current flowing out of a node as +current. Since the output stage is a current source the current flows from the IOU TP and IOU TN pins. The output current flow in each pin driving a resistive load can be expressed as:

$$I_{OUTP} = I_{OUT_{FS}} \times \text{CODE} / 65536$$

$$I_{OUTN} = I_{OUT_{FS}} \times (65535 - \text{CODE}) / 65536$$

where CODE is the decimal representation of the DAC data input word.

For the case where IOU TP and IOU TN drive resistor loads R_L directly, this translates into single ended voltages at IOU TP and IOU TN:

$$V_{OUTP} = I_{OUT1} \times R_L$$

$$V_{OUTN} = I_{OUT2} \times R_L$$

Assuming that the data is full scale (65535 in offset binary notation) and the R_L is 25 Ω , the differential voltage between pins IOU TP and IOU TN can be expressed as:

$$V_{OUTP} = 20\text{mA} \times 25 \Omega = 0.5 \text{ V}$$

$$V_{OUTN} = 0\text{mA} \times 25 \Omega = 0 \text{ V}$$

$$V_{DIFF} = V_{OUTP} - V_{OUTN} = 0.5\text{V}$$

Note that care should be taken not to exceed the compliance voltages at node IOU TP and IOU TN, which would lead to increased signal distortion.

DAC TRANSFER FUNCTION

The DAC37J82/DAC38J82 can be easily configured to drive a doubly terminated 50 Ω cable using a properly selected RF transformer. Figure 25 and Figure 26 show the 50 Ω doubly terminated transformer configuration with 1:1 and 4:1 impedance ratio, respectively. Note that the center tap of the primary input of the transformer has to be grounded to enable a DC current flow. Applying a 20 mA full-scale output current would lead to a 0.5 V_{pp} for a 1:1 transformer and a 1 V_{pp} output for a 4:1 transformer. The low dc-impedance between IOUTP or IOUTN and the transformer center tap sets the center of the ac-signal to GND, so the 1 V_{pp} output for the 4:1 transformer results in an output between -0.5 V and $+0.5$ V.

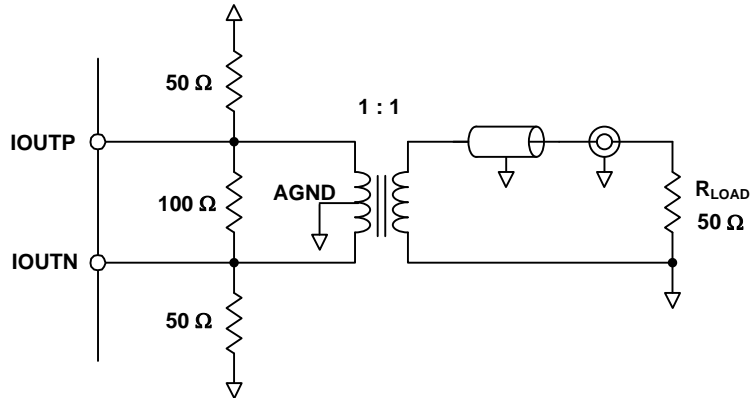

Figure 25. Driving a Doubly Terminated 50 Ω Cable Using a 1:1 Impedance Ratio Transformer

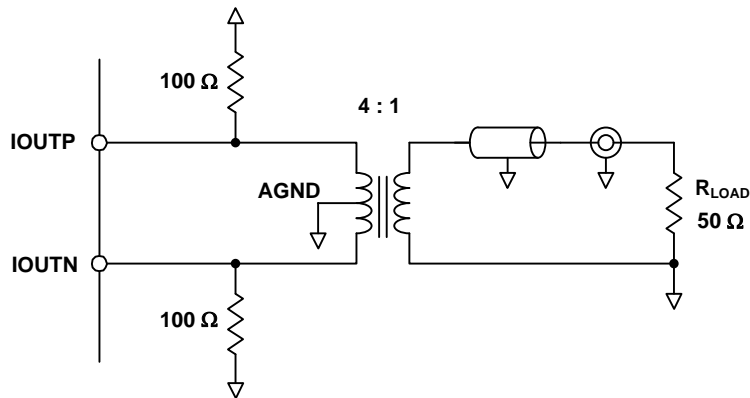

Figure 26. Driving a Doubly Terminated 50 Ω Cable Using a 4:1 Impedance Ratio Transformer

POWER UP SEQUENCE

The following start up sequence is recommended to power up DAC38J84/DAC37J84 family.

1. Set TXENABLE low
2. Supply all 0.9-V supplies (VDDDIG, VDDT, VDDDAC, VDDCLK), all 1.8-V supplies (VDDR, VDDS, VQPS, VDDIO, VDDAPLL, VDDAREF), and all 3.3-V supplies (VDDADAC). The supplies can be powered up simultaneously or in any order. There are no specific requirements on the ramp rate for the supplies.
3. RESET the JTAG port by either toggling TRSTB low if using the JTAG port or holding TRSTB low if not using JTAG.
4. Start the DACCLK generation
5. Toggle RESETB low to reset the SIF registers
6. Program the DAC PLL settings (*config26*, *config49*, *config50*, *config51*). If the PLL is not used, set *mem_pll_sleep* and *mem_pll_reset* to “1” and *mem_pll_ena* to “0”.
7. Program the SERDES settings (*config61*, *config62*) including the *mem_serdes_clk_sel* and *mem_serdes_refclk_div*.
8. Program the SERDES lane settings (*config63*, *config71*, *config73*, *config74*, *config96*).
9. Program *mem_clkjesd_div*, *mem_cdrvser_sysref_mode*, and *mem_interp*.
10. Program the JESD settings (*config3*, *config74-77*, *config79*, *config80-85*, *config92*, *config97*).
11. Program the DIG block settings (NCO, PA protection, QMC, fractional delay, etc.) and set the preferred SYNC modes for the digital blocks (*config30-32*).
12. Verify the SERDES PLL lock status by checking the SERDES PLL alarms: *alarm_rw0_pll* (alarm for lanes 0 through 3) and *alarm_rw1_pll* (alarm for lanes 4 through 7).
13. Set *mem_init_state* to “0000” and *mem_jesd_reset_n* to “1” to start the JESD204B link initialization.
14. Start the SYSREF generation.
15. Enable transmission of data by asserting the TXENABLE pin or setting *mem_sif_txenable* to “1”.
16. Clear the alarms, then wait approximately 1-2µs and check values
17. Verify that DAC output is the desired output.

REVISION HISTORY

Changes from Original (January 2014) to Revision A	Page
• Changed PIN ASSIGNMENT	3

PRODUCT PREVIEW

PACKAGING INFORMATION

Orderable Device	Status (1)	Package Type	Package Drawing	Pins	Package Qty	Eco Plan (2)	Lead/Ball Finish (6)	MSL Peak Temp (3)	Op Temp (°C)	Device Marking (4/5)	Samples
DAC37J82IAAV	PREVIEW	FCBGA	AAV	144	160	TBD	Call TI	Call TI	-40 to 85		
DAC37J82IAAVR	PREVIEW	FCBGA	AAV	144	1000	TBD	Call TI	Call TI	-40 to 85		
DAC38J82IAAV	PREVIEW	FCBGA	AAV	144	160	TBD	Call TI	Call TI	-40 to 85		
DAC38J82IAAVR	PREVIEW	FCBGA	AAV	144	1000	TBD	Call TI	Call TI	-40 to 85		
PDAC37J82IAAV	PREVIEW	FCBGA	AAV	144	160	TBD	Call TI	Call TI	25 Only		
PDAC38J82IAAV	PREVIEW	FCBGA	AAV	144	160	TBD	Call TI	Call TI	25 Only		

(1) The marketing status values are defined as follows:

ACTIVE: Product device recommended for new designs.

LIFEBUY: TI has announced that the device will be discontinued, and a lifetime-buy period is in effect.

NRND: Not recommended for new designs. Device is in production to support existing customers, but TI does not recommend using this part in a new design.

PREVIEW: Device has been announced but is not in production. Samples may or may not be available.

OBSOLETE: TI has discontinued the production of the device.

(2) Eco Plan - The planned eco-friendly classification: Pb-Free (RoHS), Pb-Free (RoHS Exempt), or Green (RoHS & no Sb/Br) - please check <http://www.ti.com/productcontent> for the latest availability information and additional product content details.

TBD: The Pb-Free/Green conversion plan has not been defined.

Pb-Free (RoHS): TI's terms "Lead-Free" or "Pb-Free" mean semiconductor products that are compatible with the current RoHS requirements for all 6 substances, including the requirement that lead not exceed 0.1% by weight in homogeneous materials. Where designed to be soldered at high temperatures, TI Pb-Free products are suitable for use in specified lead-free processes.

Pb-Free (RoHS Exempt): This component has a RoHS exemption for either 1) lead-based flip-chip solder bumps used between the die and package, or 2) lead-based die adhesive used between the die and leadframe. The component is otherwise considered Pb-Free (RoHS compatible) as defined above.

Green (RoHS & no Sb/Br): TI defines "Green" to mean Pb-Free (RoHS compatible), and free of Bromine (Br) and Antimony (Sb) based flame retardants (Br or Sb do not exceed 0.1% by weight in homogeneous material)

(3) MSL, Peak Temp. - The Moisture Sensitivity Level rating according to the JEDEC industry standard classifications, and peak solder temperature.

(4) There may be additional marking, which relates to the logo, the lot trace code information, or the environmental category on the device.

(5) Multiple Device Markings will be inside parentheses. Only one Device Marking contained in parentheses and separated by a "~" will appear on a device. If a line is indented then it is a continuation of the previous line and the two combined represent the entire Device Marking for that device.

(6) Lead/Ball Finish - Orderable Devices may have multiple material finish options. Finish options are separated by a vertical ruled line. Lead/Ball Finish values may wrap to two lines if the finish value exceeds the maximum column width.

Important Information and Disclaimer: The information provided on this page represents TI's knowledge and belief as of the date that it is provided. TI bases its knowledge and belief on information provided by third parties, and makes no representation or warranty as to the accuracy of such information. Efforts are underway to better integrate information from third parties. TI has taken and continues to take reasonable steps to provide representative and accurate information but may not have conducted destructive testing or chemical analysis on incoming materials and chemicals. TI and TI suppliers consider certain information to be proprietary, and thus CAS numbers and other limited information may not be available for release.

In no event shall TI's liability arising out of such information exceed the total purchase price of the TI part(s) at issue in this document sold by TI to Customer on an annual basis.

IMPORTANT NOTICE

Texas Instruments Incorporated and its subsidiaries (TI) reserve the right to make corrections, enhancements, improvements and other changes to its semiconductor products and services per JESD46, latest issue, and to discontinue any product or service per JESD48, latest issue. Buyers should obtain the latest relevant information before placing orders and should verify that such information is current and complete. All semiconductor products (also referred to herein as "components") are sold subject to TI's terms and conditions of sale supplied at the time of order acknowledgment.

TI warrants performance of its components to the specifications applicable at the time of sale, in accordance with the warranty in TI's terms and conditions of sale of semiconductor products. Testing and other quality control techniques are used to the extent TI deems necessary to support this warranty. Except where mandated by applicable law, testing of all parameters of each component is not necessarily performed.

TI assumes no liability for applications assistance or the design of Buyers' products. Buyers are responsible for their products and applications using TI components. To minimize the risks associated with Buyers' products and applications, Buyers should provide adequate design and operating safeguards.

TI does not warrant or represent that any license, either express or implied, is granted under any patent right, copyright, mask work right, or other intellectual property right relating to any combination, machine, or process in which TI components or services are used. Information published by TI regarding third-party products or services does not constitute a license to use such products or services or a warranty or endorsement thereof. Use of such information may require a license from a third party under the patents or other intellectual property of the third party, or a license from TI under the patents or other intellectual property of TI.

Reproduction of significant portions of TI information in TI data books or data sheets is permissible only if reproduction is without alteration and is accompanied by all associated warranties, conditions, limitations, and notices. TI is not responsible or liable for such altered documentation. Information of third parties may be subject to additional restrictions.

Resale of TI components or services with statements different from or beyond the parameters stated by TI for that component or service voids all express and any implied warranties for the associated TI component or service and is an unfair and deceptive business practice. TI is not responsible or liable for any such statements.

Buyer acknowledges and agrees that it is solely responsible for compliance with all legal, regulatory and safety-related requirements concerning its products, and any use of TI components in its applications, notwithstanding any applications-related information or support that may be provided by TI. Buyer represents and agrees that it has all the necessary expertise to create and implement safeguards which anticipate dangerous consequences of failures, monitor failures and their consequences, lessen the likelihood of failures that might cause harm and take appropriate remedial actions. Buyer will fully indemnify TI and its representatives against any damages arising out of the use of any TI components in safety-critical applications.

In some cases, TI components may be promoted specifically to facilitate safety-related applications. With such components, TI's goal is to help enable customers to design and create their own end-product solutions that meet applicable functional safety standards and requirements. Nonetheless, such components are subject to these terms.

No TI components are authorized for use in FDA Class III (or similar life-critical medical equipment) unless authorized officers of the parties have executed a special agreement specifically governing such use.

Only those TI components which TI has specifically designated as military grade or "enhanced plastic" are designed and intended for use in military/aerospace applications or environments. Buyer acknowledges and agrees that any military or aerospace use of TI components which have **not** been so designated is solely at the Buyer's risk, and that Buyer is solely responsible for compliance with all legal and regulatory requirements in connection with such use.

TI has specifically designated certain components as meeting ISO/TS16949 requirements, mainly for automotive use. In any case of use of non-designated products, TI will not be responsible for any failure to meet ISO/TS16949.

Products

Audio	www.ti.com/audio
Amplifiers	amplifier.ti.com
Data Converters	dataconverter.ti.com
DLP® Products	www.dlp.com
DSP	dsp.ti.com
Clocks and Timers	www.ti.com/clocks
Interface	interface.ti.com
Logic	logic.ti.com
Power Mgmt	power.ti.com
Microcontrollers	microcontroller.ti.com
RFID	www.ti-rfid.com
OMAP Applications Processors	www.ti.com/omap
Wireless Connectivity	www.ti.com/wirelessconnectivity

Applications

Automotive and Transportation	www.ti.com/automotive
Communications and Telecom	www.ti.com/communications
Computers and Peripherals	www.ti.com/computers
Consumer Electronics	www.ti.com/consumer-apps
Energy and Lighting	www.ti.com/energy
Industrial	www.ti.com/industrial
Medical	www.ti.com/medical
Security	www.ti.com/security
Space, Avionics and Defense	www.ti.com/space-avionics-defense
Video and Imaging	www.ti.com/video

TI E2E Community

e2e.ti.com