

DAC0800/DAC0802 8-Bit Digital-to-Analog Converters

Check for Samples: [DAC0800](#), [DAC0802](#)

FEATURES

- **Fast Settling Output Current: 100 ns**
- **Full Scale Error: ± 1 LSB**
- **Nonlinearity Over Temperature: $\pm 0.1\%$**
- **Full Scale Current Drift: ± 10 ppm/ $^{\circ}\text{C}$**
- **High Output Compliance: -10V to $+18\text{V}$**
- **Complementary Current Outputs**
- **Interface Directly with TTL, CMOS, PMOS and Others**
- **2 Quadrant Wide Range Multiplying Capability**
- **Wide Power Supply Range: $\pm 4.5\text{V}$ to $\pm 18\text{V}$**
- **Low Power Consumption: 33 mW at $\pm 5\text{V}$**
- **Low Cost**

DESCRIPTION

The DAC0800 series are monolithic 8-bit high-speed current-output digital-to-analog converters (DAC) featuring typical settling times of 100 ns. When used as a multiplying DAC, monotonic performance over a 40 to 1 reference current range is possible. The DAC0800 series also features high compliance complementary current outputs to allow differential output voltages of 20 V_{p-p} with simple resistor loads. The reference-to-full-scale current matching of better than ± 1 LSB eliminates the need for full-scale trims in most applications, while the nonlinearities of better than $\pm 0.1\%$ over temperature minimizes system error accumulations.

The noise immune inputs will accept a variety of logic levels. The performance and characteristics of the device are essentially unchanged over the $\pm 4.5\text{V}$ to $\pm 18\text{V}$ power supply range and power consumption at only 33 mW with $\pm 5\text{V}$ supplies is independent of logic input levels.

The DAC0800, DAC0802, DAC0800C and DAC0802C are a direct replacement for the DAC-08, DAC-08A, DAC-08C, and DAC-08H, respectively. For single supply operation, refer to AN-1525.

Typical Application

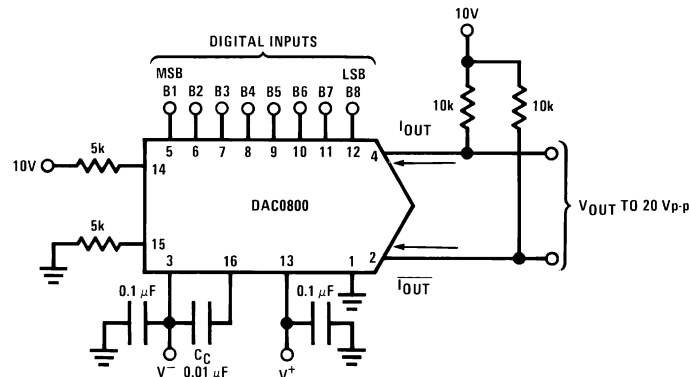

Pin numbers represent the PDIP package. The SOIC package pin numbers differ from that of the PDIP package.

Figure 1. ± 20 V_{p-p} Output Digital-to-Analog Converter



These devices have limited built-in ESD protection. The leads should be shorted together or the device placed in conductive foam during storage or handling to prevent electrostatic damage to the MOS gates.



Please be aware that an important notice concerning availability, standard warranty, and use in critical applications of Texas Instruments semiconductor products and disclaimers thereto appears at the end of this data sheet.

All trademarks are the property of their respective owners.

Absolute Maximum Ratings ⁽¹⁾

Supply Voltage ($V^+ - V^-$)	$\pm 18V$ or $36V$
Power Dissipation ⁽²⁾	500 mW
Reference Input Differential Voltage (V14 to V15)	V^- to V^+
Reference Input Common-Mode Range (V14, V15)	V^- to V^+
Reference Input Current	5 mA
Logic Inputs	V^- to V^- plus $36V$
Analog Current Outputs ($V_{S^-} = -15V$)	4.25 mA
ESD Susceptibility ⁽³⁾	TBD V
Storage Temperature	$-65^\circ C$ to $+150^\circ C$
Lead Temp. (Soldering, 10 seconds)	
PDIP Package (plastic)	$260^\circ C$
CDIP Package (ceramic)	$300^\circ C$
Surface Mount Package	
Vapor Phase (60 seconds)	$215^\circ C$
Infrared (15 seconds)	$220^\circ C$

- (1) Absolute Maximum Ratings indicate limits beyond which damage to the device may occur. DC and AC electrical specifications do not apply when operating the device beyond its specified operating conditions.
- (2) The maximum junction temperature of the DAC0800 and DAC0802 is $125^\circ C$. For operating at elevated temperatures, devices in the CDIP package must be derated based on a thermal resistance of $100^\circ C/W$, junction-to-ambient, $175^\circ C/W$ for the molded PDIP package and $100^\circ C/W$ for the SOIC package.
- (3) Human body model, 100 pF discharged through a 1.5 k Ω resistor.

Operating Conditions ⁽¹⁾

	Min	Max	Units
Temperature (T_A)			
DAC0800L	-55	+125	$^\circ C$
DAC0800LC	0	+70	$^\circ C$
DAC0802LC	0	+70	$^\circ C$
V^+	$(V^-) + 10$	$(V^-) + 30$	V
V^-	-15	-5	V
I_{REF} ($V^- = -5V$)	1	2	mA
I_{REF} ($V^- = -15V$)	1	4	mA

- (1) Absolute Maximum Ratings indicate limits beyond which damage to the device may occur. DC and AC electrical specifications do not apply when operating the device beyond its specified operating conditions.

Electrical Characteristics

The following specifications apply for $V_S = \pm 15V$, $I_{REF} = 2\text{ mA}$ and $T_{MIN} \leq T_A \leq T_{MAX}$ unless otherwise specified. Output characteristics refer to both I_{OUT} and \bar{I}_{OUT} .

Parameter	Test Conditions	DAC0802LC			DAC0800L/ DAC0800LC			Units			
		Min	Typ	Max	Min	Typ	Max				
Resolution		8	8	8	8	8	8	Bits			
Monotonicity		8	8	8	8	8	8	Bits			
Nonlinearity				±0.1			±0.19	%FS			
t_s	Settling Time	To ±½ LSB, All Bits Switched "ON" or "OFF", $T_A=25^\circ\text{C}$		100	135			ns			
		DAC0800L				100	135	ns			
		DAC0800LC				100	150	ns			
t_{PLH} , t_{PHL}	Propagation Delay	$T_A=25^\circ\text{C}$									
	Each Bit		35	60		35	60	ns			
	All Bits Switched		35	60		35	60	ns			
TCI_{FS}	Full Scale Tempco		±10	±50		±10	±50	ppm/°C			
V_{OC}	Output Voltage Compliance	Full Scale Current Change <½ LSB, $R_{OUT}>20\text{ M}\Omega$, Typical		-10		18	-10	18	V		
I_{FS4}	Full Scale Current	$V_{REF} = 10.000V$, $R_{14} = R_{15} = 5.000\text{ k}\Omega$, $T_A=25^\circ\text{C}$		1.984	1.992	2.00	1.94	1.99	2.04	mA	
I_{FSS}	Full Scale Symmetry	$I_{FS4} - I_{FS2}$			±0.5	±4.0		±1	±8.0	µA	
I_{ZS}	Zero Scale Current		0.1	1.0		0.2	2.0		µA		
I_{FSR}	Output Current Range	$V^- = -5V$ $V^- = -8V\text{ to }-18V$		0	2.0	2.1	0	2.0	2.1	4.2	mA
V_{IL} V_{IH}	Logic Input Levels	$V_{LC} = 0V$				0.8			0.8	V	
	Logic "0" Logic "1"		2.0			2.0				V	
I_{IL} I_{IH}	Logic Input Current	$V_{LC} = 0V$									
	Logic "0" Logic "1"	$-10V \leq V_{IN} \leq +0.8V$ $2V \leq V_{IN} \leq +18V$			-2.0	-10		-2.0	-10	µA	
			0.002	10		0.002	10		µA		
V_{IS}	Logic Input Swing	$V^- = -15V$		-10		18	-10		18	V	
V_{THR}	Logic Threshold Range	$V_S = \pm 15V$		-10		13.5	-10		13.5	V	
I_{15}	Reference Bias Current		-1.0	-3.0		-1.0	-3.0		µA		
dI/dt	Reference Input Slew Rate	(Figure 26)		4.0	8.0		4.0	8.0		mA/µs	
$PSSI_{FS+}$	Positive Power Supply Sensitivity	$4.5V \leq V^+ \leq 18V$			0.0001	0.01		0.0001	0.01	%/%	
$PSSI_{FS-}$	Negative Power Supply Sensitivity	$-4.5V \leq V^- \leq 18V$, $I_{REF} = 1\text{ mA}$			0.0001	0.01		0.0001	0.01	%/%	
I_+ I_-	Power Supply Current	$V_S = \pm 5V$, $I_{REF} = 1\text{ mA}$			2.3	3.8		2.3	3.8	mA	
			-4.3	-5.8		-4.3	-5.8	mA			
I_+ I_-	Power Supply Current	$V_S = +5V, -15V$, $I_{REF} = 2\text{ mA}$			2.4	3.8		2.4	3.8	mA	
			-6.4	-7.8		-6.4	-7.8	mA			
I_+ I_-	Power Supply Current	$V_S = \pm 15V$, $I_{REF} = 2\text{ mA}$			2.5	3.8		2.5	3.8	mA	
			-6.5	-7.8		-6.5	-7.8	mA			
P_D	Power Consumption	$\pm 5V$, $I_{REF} = 1\text{ mA}$			33	48		33	48	mW	
		$+5V, -15V$, $I_{REF} = 2\text{ mA}$			108	136		108	136	mW	
		$\pm 15V$, $I_{REF} = 2\text{ mA}$			135	174		135	174	mW	

Connection Diagrams

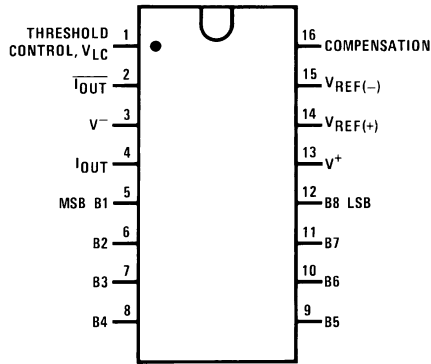

Figure 2. PDIP, CDIP Packages - Top View
(See Package Number NFG0016E or NFE0016A)

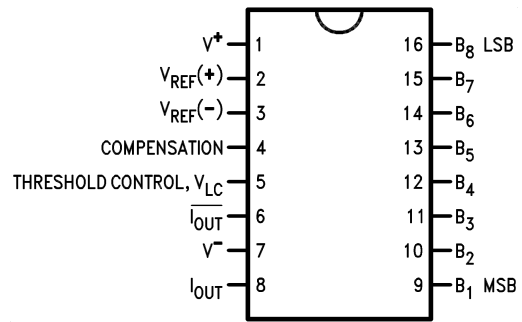
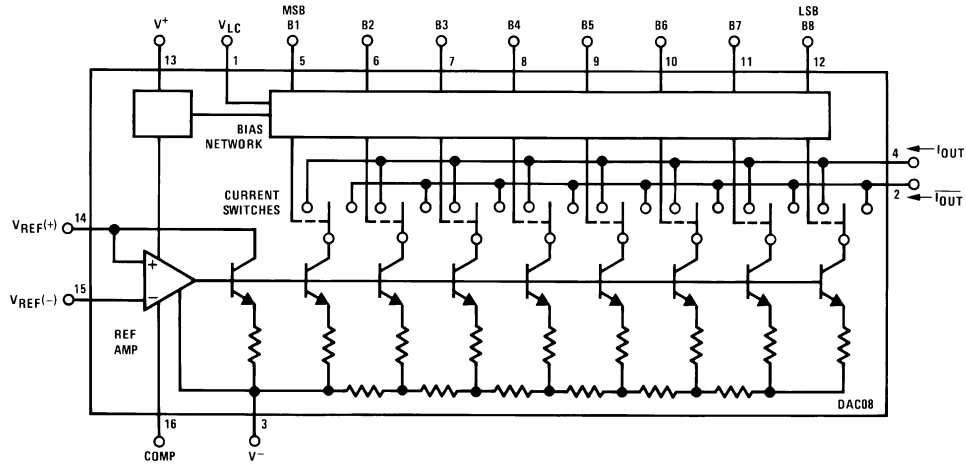

Figure 3. SOIC Package - Top View
(See Package Number D0016A)

Block Diagram



Pin numbers represent the PDIP package. The SOIC package pin numbers differ from that of the PDIP package.

Figure 4.

Typical Performance Characteristics

Full Scale Current vs. Reference Current

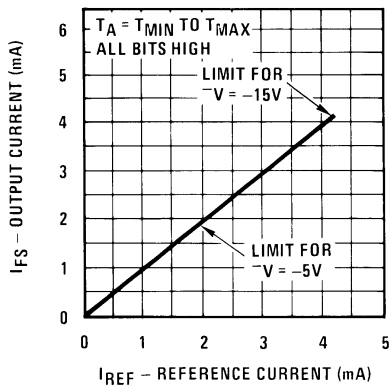

Figure 5.

LSB Propagation Delay vs. IFS

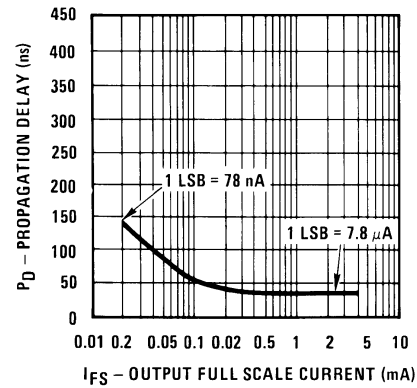
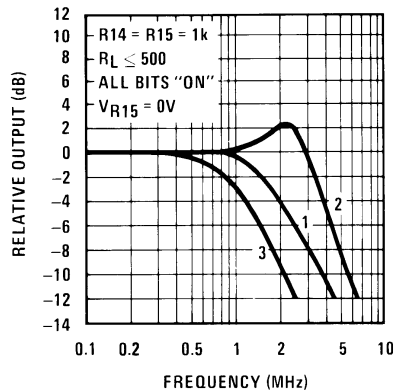

Figure 6.

Reference Input Frequency Response



Curve 1: $C_C=15$ pF, $V_{IN}=2$ Vp-p centered at 1V.
 Curve 2: $C_C=15$ pF, $V_{IN}=50$ mVp-p centered at 200 mV.
 Curve 3: $C_C=0$ pF, $V_{IN}=100$ mVp-p centered at 0V and applied through 50Ω connected to pin 14. 2V applied to R14.

Figure 7.

Reference Amp Common-Mode Range

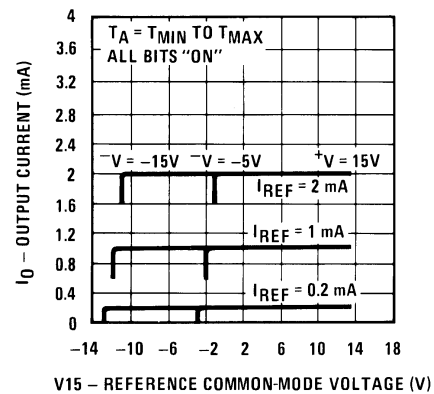

Note. Positive common-mode range is always $(V+) - 1.5V$.

Figure 8.

Logic Input Current vs. Input Voltage

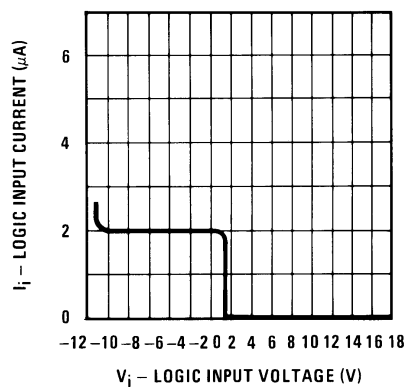

Figure 9.

VTH - VLC vs. Temperature

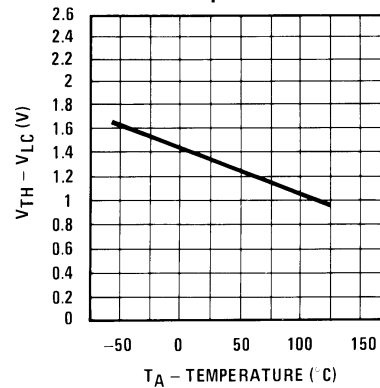

Figure 10.

Typical Performance Characteristics (continued)

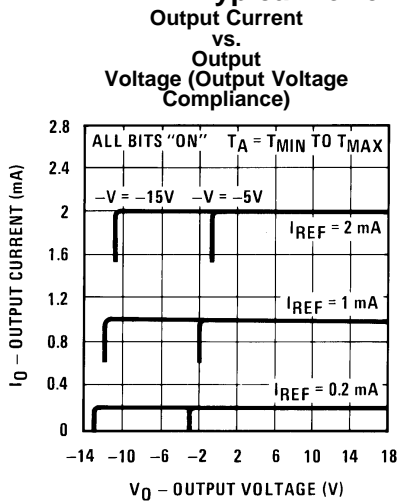

Figure 11.

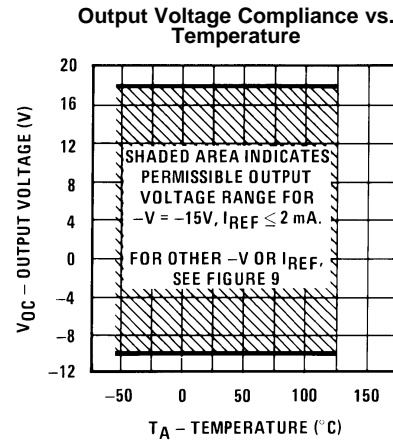
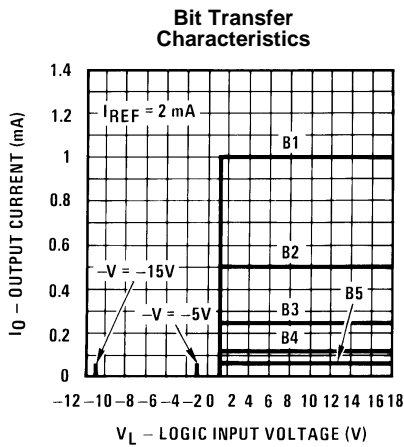

Figure 12.



Note. B1–B8 have identical transfer characteristics. Bits are fully switched with less than 1/2 LSB error, at less than ±100 mV from actual threshold. These switching points are guaranteed to lie between 0.8 and 2V over the operating temperature range ($V_{LC} = 0V$).

Figure 13.

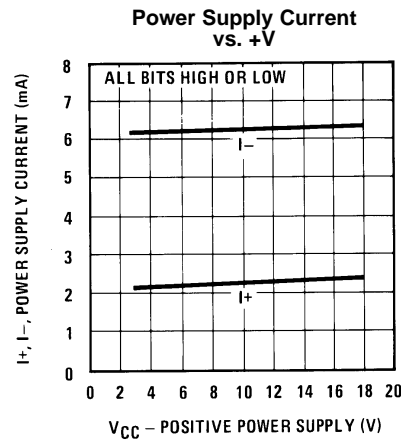

Figure 14.

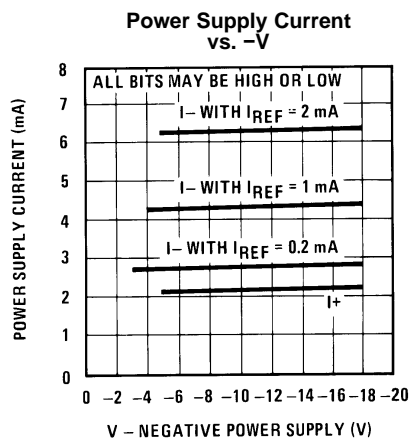

Figure 15.

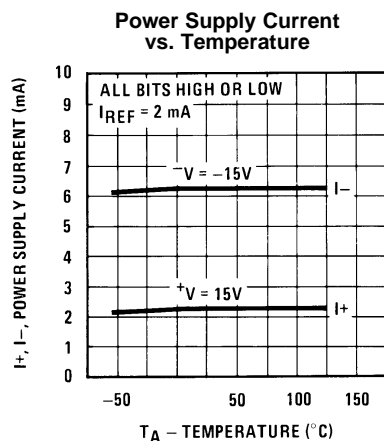

Figure 16.

EQUIVALENT CIRCUIT

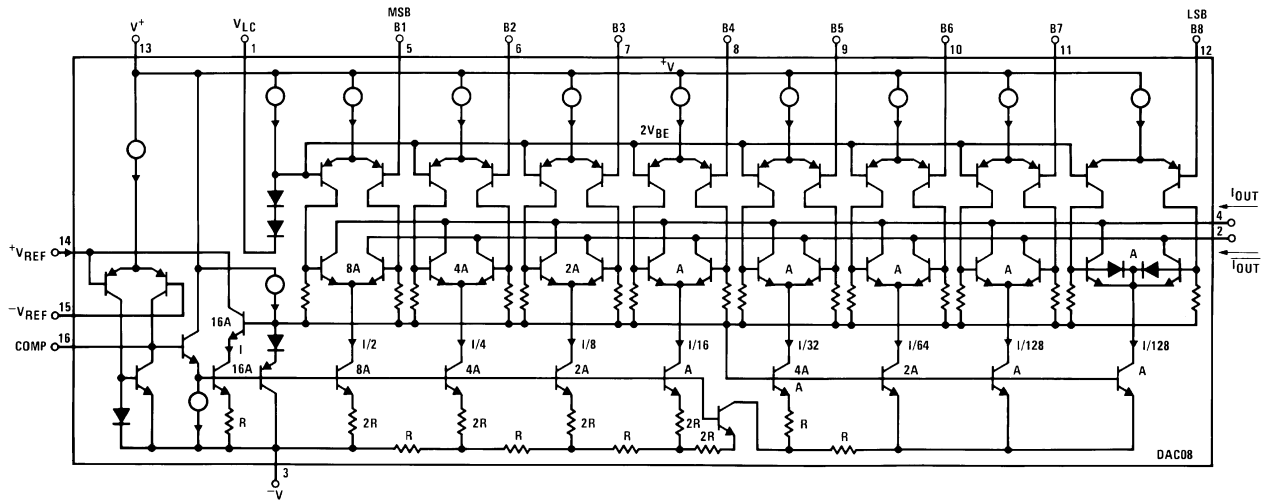
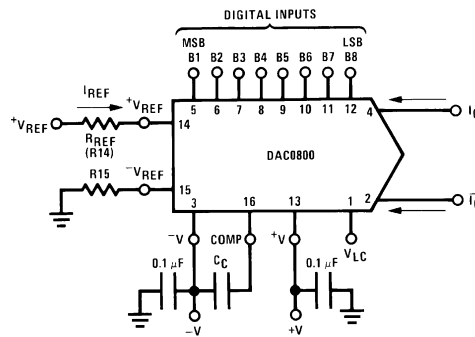

Figure 17. Equivalent Circuit

TYPICAL APPLICATIONS



Pin numbers represent the PDIP package. The SOIC package pin numbers differ from that of the PDIP package.

$$I_{FS} \approx \frac{+V_{REF}}{R_{REF}} \times \frac{255}{256}$$

$I_O + \bar{I}_O = I_{FS}$ for all logic states

For fixed reference, TTL operation, typical values are:

$V_{REF} = 10.000V$

$R_{REF} = 5.000k$

$R_{15} \approx R_{REF}$

$C_C = 0.01 \mu F$

$V_{LC} = 0V$ (Ground)

Figure 18. Basic Positive Reference Operation

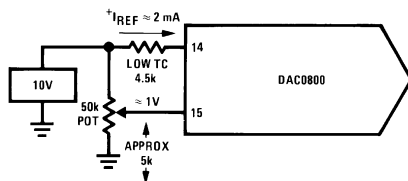

Figure 19. Recommended Full Scale Adjustment Circuit

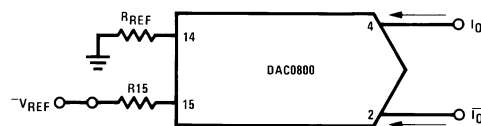
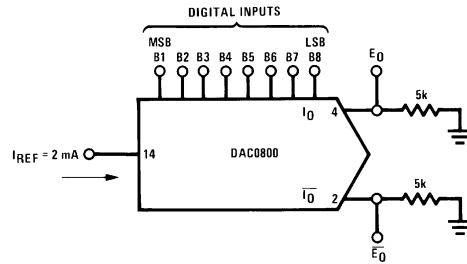

Figure 20. Basic Negative Reference Operation

Pin numbers represent the PDIP package. The SOIC package pin numbers differ from that of the PDIP package.



Pin numbers represent the PDIP package. The SOIC package pin numbers differ from that of the PDIP package.

Figure 21. Basic Unipolar Negative Operation

Table 1. Basic Unipolar Negative Operation

	B1	B2	B3	B4	B5	B6	B7	B8	I _O mA	I _O -mA	E _O	E _O -
Full Scale	1	1	1	1	1	1	1	1	1.992	0.000	-9.960	0.000
Full Scale-LSB	1	1	1	1	1	1	1	0	1.984	0.008	-9.920	-0.040
Half Scale+LSB	1	0	0	0	0	0	0	1	1.008	0.984	-5.040	-4.920
Half Scale	1	0	0	0	0	0	0	0	1.000	0.992	-5.000	-4.960
Half Scale-LSB	0	1	1	1	1	1	1	1	0.992	1.000	-4.960	-5.000
Zero Scale+LSB	0	0	0	0	0	0	0	1	0.008	1.984	-0.040	-9.920
Zero Scale	0	0	0	0	0	0	0	0	0.000	1.992	0.000	-9.960

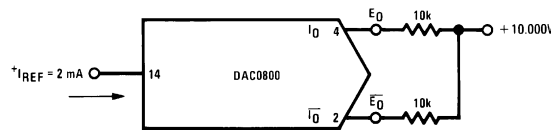

Pin numbers represent the PDIP package. The SOIC package pin numbers differ from that of the PDIP package.

Figure 22. Basic Bipolar Output Operation

Table 2. Basic Bipolar Output Operation

	B1	B2	B3	B4	B5	B6	B7	B8	E _O	E _O -
Pos. Full Scale	1	1	1	1	1	1	1	1	-9.920	+10.000
Pos. Full Scale-LSB	1	1	1	1	1	1	1	0	-9.840	+9.920
Zero Scale+LSB	1	0	0	0	0	0	0	1	-0.080	+0.160
Zero Scale	1	0	0	0	0	0	0	0	0.000	+0.080
Zero Scale-LSB	0	1	1	1	1	1	1	1	+0.080	0.000
Neg. Full Scale+LSB	0	0	0	0	0	0	0	1	+9.920	-9.840
Neg. Full Scale	0	0	0	0	0	0	0	0	+10.000	-9.920

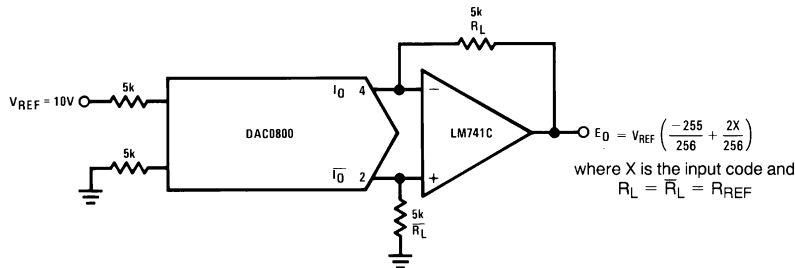

- (1) Pin numbers represent the PDIP package. The SOIC package pin numbers differ from that of the PDIP package.
- (2) If $R_L = \bar{R}_L$ within $\pm 0.05\%$, output is symmetrical about ground.

Figure 23. Symmetrical Offset Binary Operation

Table 3. Symmetrical Offset Binary Operation

	B1	B2	B3	B4	B5	B6	B7	B8	E_O
Pos. Full Scale	1	1	1	1	1	1	1	1	+9.960
Pos. Full Scale-LSB	1	1	1	1	1	1	1	0	+9.880
(+)Zero Scale	1	0	0	0	0	0	0	0	+0.040
(-)Zero Scale	0	1	1	1	1	1	1	1	-0.040
Neg. Full Scale+LSB	0	0	0	0	0	0	0	1	-9.880
Neg. Full Scale	0	0	0	0	0	0	0	0	-9.960

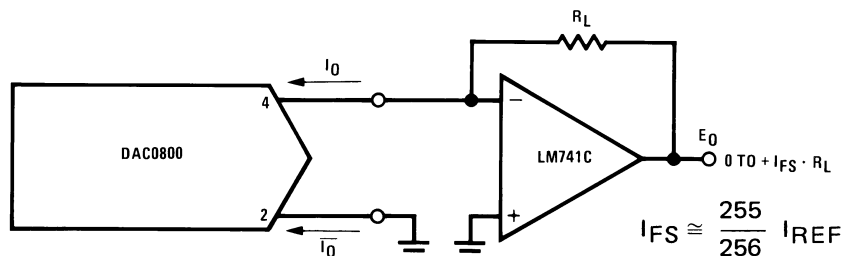

- (1) Pin numbers represent the PDIP package. The SOIC package pin numbers differ from that of the PDIP package.
- (2) For complementary output (operation as negative logic DAC), connect inverting input of op amp to \bar{I}_O (pin 2), connect I_O (pin 4) to ground.

Figure 24. Positive Low Impedance Output Operation

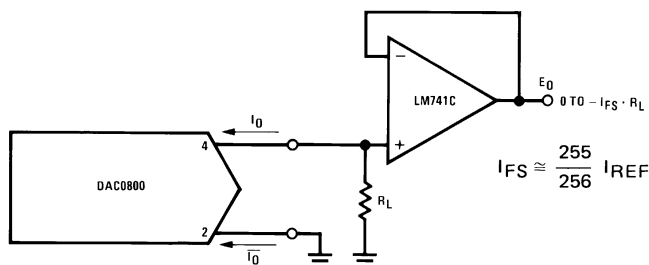

- (1) Pin numbers represent the PDIP package. The SOIC package pin numbers differ from that of the PDIP package.
- (2) For complementary output (operation as a negative logic DAC) connect non-inverting input of op am to \bar{I}_O (pin 2); connect I_O (pin 4) to ground.

Figure 25. Negative Low Impedance Output Operation

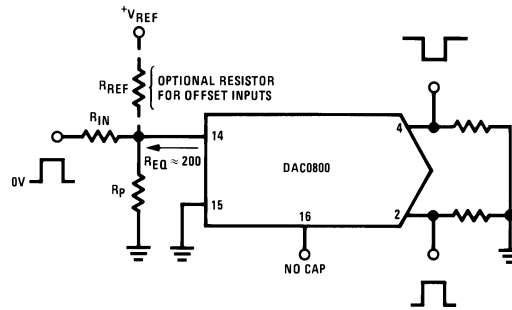

Typical values: $R_{IN}=5k, +V_{IN}=10V$

Pin numbers represent the PDIP package. The SOIC package pin numbers differ from that of the PDIP package.

Figure 26. Pulsed Reference Operation

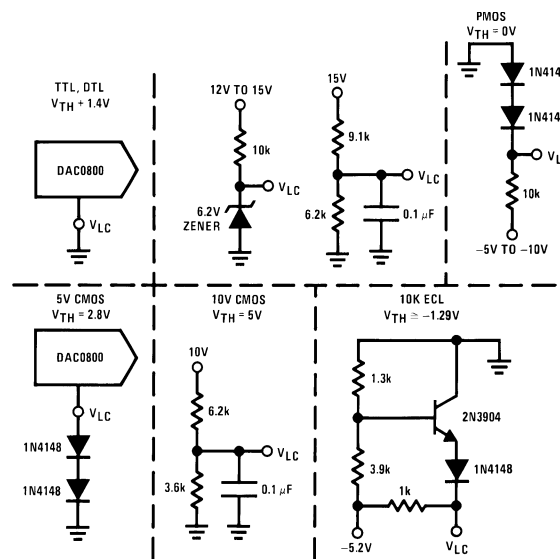

$V_{TH} = V_{LC} + 1.4V$
 15V CMOS, HTL, HN1L
 $V_{TH} = 7.6V$

Note. Do not exceed negative logic input range of DAC.

Figure 27. Interfacing with Various Logic Families

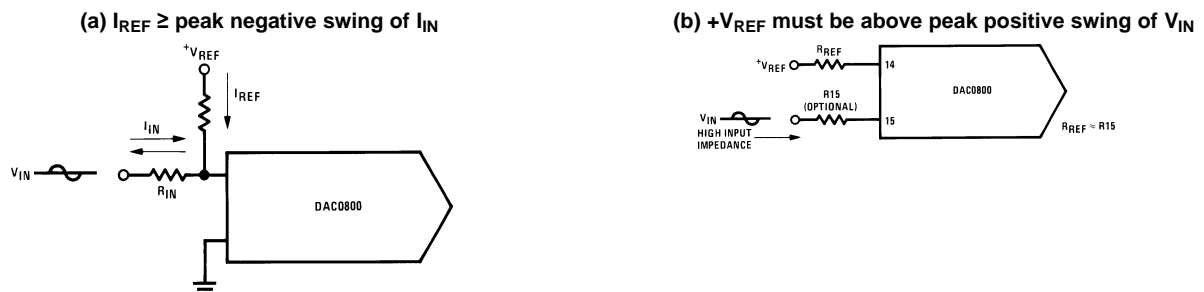

Pin numbers represent the PDIP package. The SOIC package pin numbers differ from that of the PDIP package.

Figure 28. Accommodating Bipolar References

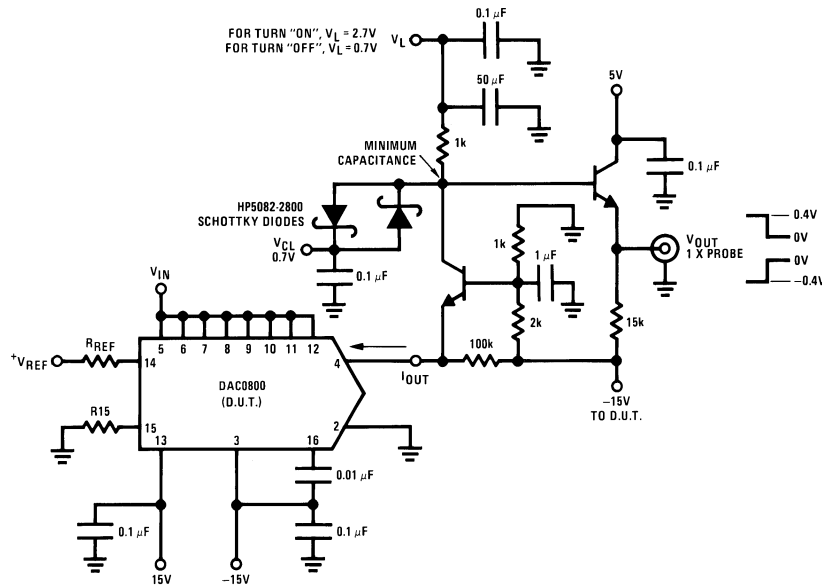

Pin numbers represent the PDIP package. The SOIC package pin numbers differ from that of the PDIP package.

Figure 29. Settling Time Measurement

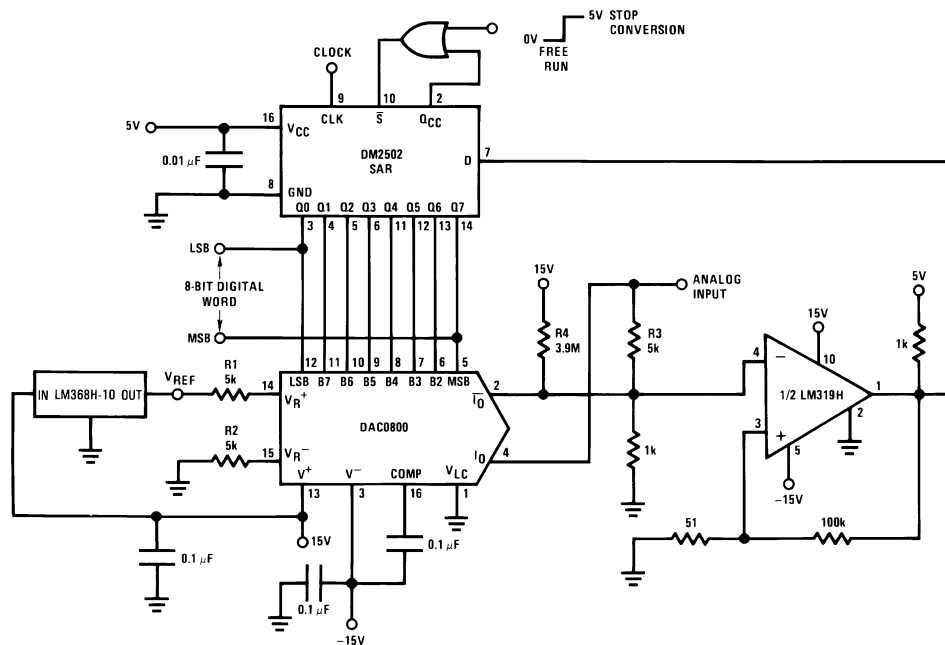

- (1) For 1 µs conversion time with 8-bit resolution and 7-bit accuracy, an LM361 comparator replaces the LM319 and the reference current is doubled by reducing R1, R2 and R3 to 2.5 kΩ and R4 to 2 MΩ.
- (2) Pin numbers represent the PDIP package. The SOIC package pin numbers differ from that of the PDIP package.

Figure 30. A Complete 2 µs Conversion Time, 8-Bit A/D Converter

REVISION HISTORY

Changes from Revision B (February 2013) to Revision C	Page
<hr/> <ul style="list-style-type: none">• Changed layout of National Data Sheet to TI format	<hr/> 12

PACKAGING INFORMATION

Orderable Device	Status (1)	Package Type	Package Drawing	Pins	Package Qty	Eco Plan (2)	Lead/Ball Finish (6)	MSL Peak Temp (3)	Op Temp (°C)	Device Marking (4/5)	Samples
DAC-08EP	NRND	PDIP	NFG	16	25	TBD	Call TI	Call TI	0 to 70	DAC0800LCN DAC-08EP	
DAC0800LCM	NRND	SOIC	D	16	48	TBD	Call TI	Call TI	0 to 70	DAC0800LCM	
DAC0800LCM/NOPB	ACTIVE	SOIC	D	16	48	Green (RoHS & no Sb/Br)	CU SN	Level-1-260C-UNLIM	0 to 70	DAC0800LCM	Samples
DAC0800LCMX	NRND	SOIC	D	16	2500	TBD	Call TI	Call TI	0 to 70	DAC0800LCM	
DAC0800LCMX/NOPB	ACTIVE	SOIC	D	16	2500	Green (RoHS & no Sb/Br)	CU SN	Level-1-260C-UNLIM	0 to 70	DAC0800LCM	Samples
DAC0800LCN	NRND	PDIP	NFG	16	25	TBD	Call TI	Call TI	0 to 70	DAC0800LCN DAC-08EP	
DAC0800LCN/NOPB	ACTIVE	PDIP	NFG	16	25	Pb-Free (RoHS)	SN	Level-1-NA-UNLIM	0 to 70	DAC0800LCN DAC-08EP	Samples
DAC0802LCMX	NRND	SOIC	D	16	2500	TBD	Call TI	Call TI	0 to 70	DAC0802LCM	
DAC0802LCMX/NOPB	ACTIVE	SOIC	D	16	2500	Green (RoHS & no Sb/Br)	CU SN	Level-1-260C-UNLIM	0 to 70	DAC0802LCM	Samples

(1) The marketing status values are defined as follows:

ACTIVE: Product device recommended for new designs.

LIFEBUY: TI has announced that the device will be discontinued, and a lifetime-buy period is in effect.

NRND: Not recommended for new designs. Device is in production to support existing customers, but TI does not recommend using this part in a new design.

PREVIEW: Device has been announced but is not in production. Samples may or may not be available.

OBSOLETE: TI has discontinued the production of the device.

(2) Eco Plan - The planned eco-friendly classification: Pb-Free (RoHS), Pb-Free (RoHS Exempt), or Green (RoHS & no Sb/Br) - please check <http://www.ti.com/productcontent> for the latest availability information and additional product content details.

TBD: The Pb-Free/Green conversion plan has not been defined.

Pb-Free (RoHS): TI's terms "Lead-Free" or "Pb-Free" mean semiconductor products that are compatible with the current RoHS requirements for all 6 substances, including the requirement that lead not exceed 0.1% by weight in homogeneous materials. Where designed to be soldered at high temperatures, TI Pb-Free products are suitable for use in specified lead-free processes.

Pb-Free (RoHS Exempt): This component has a RoHS exemption for either 1) lead-based flip-chip solder bumps used between the die and package, or 2) lead-based die adhesive used between the die and leadframe. The component is otherwise considered Pb-Free (RoHS compatible) as defined above.

Green (RoHS & no Sb/Br): TI defines "Green" to mean Pb-Free (RoHS compatible), and free of Bromine (Br) and Antimony (Sb) based flame retardants (Br or Sb do not exceed 0.1% by weight in homogeneous material)

(3) MSL, Peak Temp. - The Moisture Sensitivity Level rating according to the JEDEC industry standard classifications, and peak solder temperature.

(4) There may be additional marking, which relates to the logo, the lot trace code information, or the environmental category on the device.

⁽⁵⁾ Multiple Device Markings will be inside parentheses. Only one Device Marking contained in parentheses and separated by a "~" will appear on a device. If a line is indented then it is a continuation of the previous line and the two combined represent the entire Device Marking for that device.

⁽⁶⁾ Lead/Ball Finish - Orderable Devices may have multiple material finish options. Finish options are separated by a vertical ruled line. Lead/Ball Finish values may wrap to two lines if the finish value exceeds the maximum column width.

Important Information and Disclaimer:The information provided on this page represents TI's knowledge and belief as of the date that it is provided. TI bases its knowledge and belief on information provided by third parties, and makes no representation or warranty as to the accuracy of such information. Efforts are underway to better integrate information from third parties. TI has taken and continues to take reasonable steps to provide representative and accurate information but may not have conducted destructive testing or chemical analysis on incoming materials and chemicals. TI and TI suppliers consider certain information to be proprietary, and thus CAS numbers and other limited information may not be available for release.

In no event shall TI's liability arising out of such information exceed the total purchase price of the TI part(s) at issue in this document sold by TI to Customer on an annual basis.

TAPE AND REEL INFORMATION

QUADRANT ASSIGNMENTS FOR PIN 1 ORIENTATION IN TAPE

*All dimensions are nominal

Device	Package Type	Package Drawing	Pins	SPQ	Reel Diameter (mm)	Reel Width W1 (mm)	A0 (mm)	B0 (mm)	K0 (mm)	P1 (mm)	W (mm)	Pin1 Quadrant
DAC0800LCMX	SOIC	D	16	2500	330.0	16.4	6.5	10.3	2.3	8.0	16.0	Q1
DAC0800LCMX/NOPB	SOIC	D	16	2500	330.0	16.4	6.5	10.3	2.3	8.0	16.0	Q1
DAC0802LCMX	SOIC	D	16	2500	330.0	16.4	6.5	10.3	2.3	8.0	16.0	Q1
DAC0802LCMX/NOPB	SOIC	D	16	2500	330.0	16.4	6.5	10.3	2.3	8.0	16.0	Q1

TAPE AND REEL BOX DIMENSIONS

*All dimensions are nominal

Device	Package Type	Package Drawing	Pins	SPQ	Length (mm)	Width (mm)	Height (mm)
DAC0800LCMX	SOIC	D	16	2500	367.0	367.0	35.0
DAC0800LCMX/NOPB	SOIC	D	16	2500	367.0	367.0	35.0
DAC0802LCMX	SOIC	D	16	2500	367.0	367.0	35.0
DAC0802LCMX/NOPB	SOIC	D	16	2500	367.0	367.0	35.0

NFG0016E

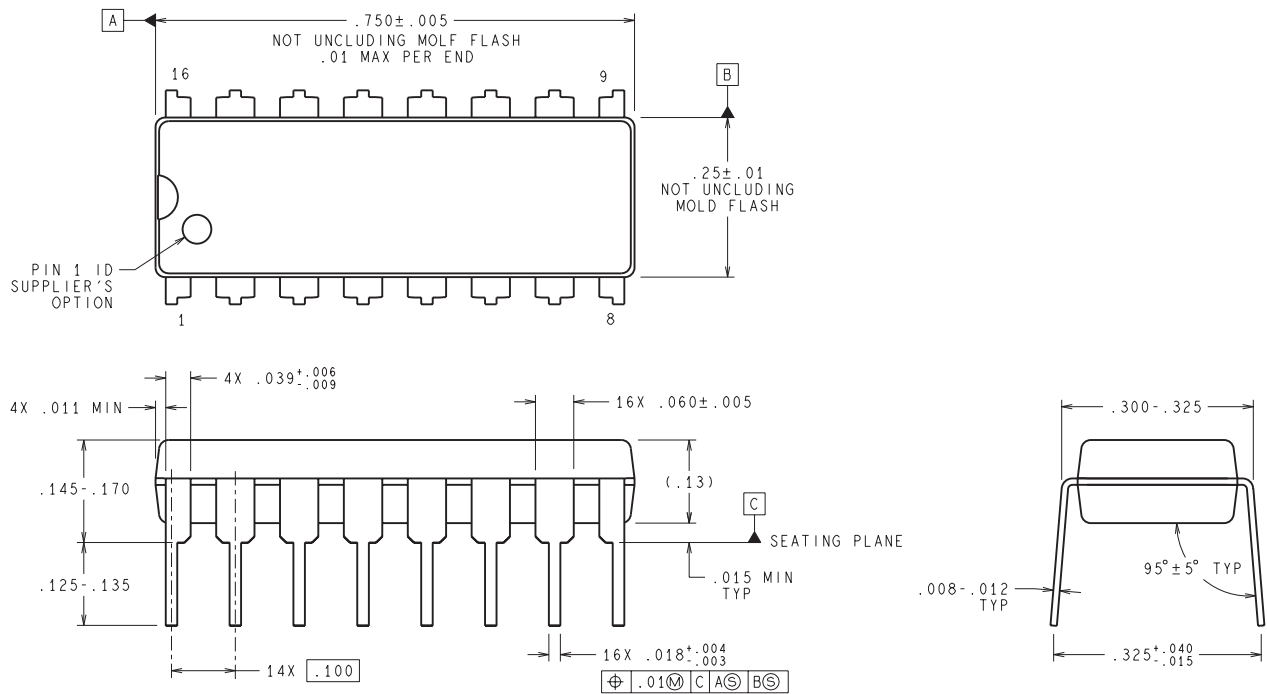

DIMENSIONS ARE IN INCHES
DIMENSIONS IN () FOR REFERENCE ONLY

N16E (Rev G)

D (R-PDSO-G16)

PLASTIC SMALL OUTLINE



- NOTES:
- A. All linear dimensions are in inches (millimeters).
 - B. This drawing is subject to change without notice.
 - C. Body length does not include mold flash, protrusions, or gate burrs. Mold flash, protrusions, or gate burrs shall not exceed 0.006 (0,15) each side.
 - D. Body width does not include interlead flash. Interlead flash shall not exceed 0.017 (0,43) each side.
 - E. Reference JEDEC MS-012 variation AC.

IMPORTANT NOTICE

Texas Instruments Incorporated and its subsidiaries (TI) reserve the right to make corrections, enhancements, improvements and other changes to its semiconductor products and services per JESD46, latest issue, and to discontinue any product or service per JESD48, latest issue. Buyers should obtain the latest relevant information before placing orders and should verify that such information is current and complete. All semiconductor products (also referred to herein as "components") are sold subject to TI's terms and conditions of sale supplied at the time of order acknowledgment.

TI warrants performance of its components to the specifications applicable at the time of sale, in accordance with the warranty in TI's terms and conditions of sale of semiconductor products. Testing and other quality control techniques are used to the extent TI deems necessary to support this warranty. Except where mandated by applicable law, testing of all parameters of each component is not necessarily performed.

TI assumes no liability for applications assistance or the design of Buyers' products. Buyers are responsible for their products and applications using TI components. To minimize the risks associated with Buyers' products and applications, Buyers should provide adequate design and operating safeguards.

TI does not warrant or represent that any license, either express or implied, is granted under any patent right, copyright, mask work right, or other intellectual property right relating to any combination, machine, or process in which TI components or services are used. Information published by TI regarding third-party products or services does not constitute a license to use such products or services or a warranty or endorsement thereof. Use of such information may require a license from a third party under the patents or other intellectual property of the third party, or a license from TI under the patents or other intellectual property of TI.

Reproduction of significant portions of TI information in TI data books or data sheets is permissible only if reproduction is without alteration and is accompanied by all associated warranties, conditions, limitations, and notices. TI is not responsible or liable for such altered documentation. Information of third parties may be subject to additional restrictions.

Resale of TI components or services with statements different from or beyond the parameters stated by TI for that component or service voids all express and any implied warranties for the associated TI component or service and is an unfair and deceptive business practice. TI is not responsible or liable for any such statements.

Buyer acknowledges and agrees that it is solely responsible for compliance with all legal, regulatory and safety-related requirements concerning its products, and any use of TI components in its applications, notwithstanding any applications-related information or support that may be provided by TI. Buyer represents and agrees that it has all the necessary expertise to create and implement safeguards which anticipate dangerous consequences of failures, monitor failures and their consequences, lessen the likelihood of failures that might cause harm and take appropriate remedial actions. Buyer will fully indemnify TI and its representatives against any damages arising out of the use of any TI components in safety-critical applications.

In some cases, TI components may be promoted specifically to facilitate safety-related applications. With such components, TI's goal is to help enable customers to design and create their own end-product solutions that meet applicable functional safety standards and requirements. Nonetheless, such components are subject to these terms.

No TI components are authorized for use in FDA Class III (or similar life-critical medical equipment) unless authorized officers of the parties have executed a special agreement specifically governing such use.

Only those TI components which TI has specifically designated as military grade or "enhanced plastic" are designed and intended for use in military/aerospace applications or environments. Buyer acknowledges and agrees that any military or aerospace use of TI components which have **not** been so designated is solely at the Buyer's risk, and that Buyer is solely responsible for compliance with all legal and regulatory requirements in connection with such use.

TI has specifically designated certain components as meeting ISO/TS16949 requirements, mainly for automotive use. In any case of use of non-designated products, TI will not be responsible for any failure to meet ISO/TS16949.

Products

Audio	www.ti.com/audio
Amplifiers	amplifier.ti.com
Data Converters	dataconverter.ti.com
DLP® Products	www.dlp.com
DSP	dsp.ti.com
Clocks and Timers	www.ti.com/clocks
Interface	interface.ti.com
Logic	logic.ti.com
Power Mgmt	power.ti.com
Microcontrollers	microcontroller.ti.com
RFID	www.ti-rfid.com
OMAP Applications Processors	www.ti.com/omap
Wireless Connectivity	www.ti.com/wirelessconnectivity

Applications

Automotive and Transportation	www.ti.com/automotive
Communications and Telecom	www.ti.com/communications
Computers and Peripherals	www.ti.com/computers
Consumer Electronics	www.ti.com/consumer-apps
Energy and Lighting	www.ti.com/energy
Industrial	www.ti.com/industrial
Medical	www.ti.com/medical
Security	www.ti.com/security
Space, Avionics and Defense	www.ti.com/space-avionics-defense
Video and Imaging	www.ti.com/video

TI E2E Community

e2e.ti.com