

CSD95372BQ5MC Synchronous Buck NexFET™ Smart Power Stage

1 Features

- 60 A Continuous Operating Current Capability
- 93.4% System Efficiency at 30 A
- Low Power Loss of 2.8 W at 30 A
- High Frequency Operation (up to 1.25 MHz)
- Diode Emulation Mode With FCCM
- Temperature Compensated Bi-Directional Current Sense
- Analog Temperature Output (600 mV at 0°C)
- Fault Monitoring
 - Highside Short, Overcurrent, and Overtemperature Protection
- 3.3 V and 5 V PWM Signal Compatible
- Tri-State PWM Input
- Integrated Bootstrap Diode
- Optimized Deadtime for Shoot Through Protection
- High Density SON 5 × 6 mm Footprint
- Ultra Low Inductance Package
- System Optimized PCB Footprint
- DualCool™ Packaging
- RoHS Compliant – Lead Free Terminal Plating
- Halogen Free

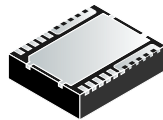

2 Applications

- Multiphase Synchronous Buck Converters
 - High Frequency Applications
 - High Current, Low Duty Cycle Applications
- POL DC-DC Converters
- Memory and Graphic Cards
- Desktop and Server VR11.x / VR12.x V-Core and Memory Synchronous Converters

3 Description

The CSD95372BQ5MC NexFET™ smart power stage is a highly optimized design for use in a high-power, high-density synchronous buck converter. This product integrates the driver IC and Power MOSFETs to complete the power stage switching function. This combination produces high current, high efficiency, and high speed switching capability in a small 5 mm × 6 mm outline package. It also integrates the accurate current sensing system and temperature sensing functionality to simplify system design and improve accuracy. In addition, the PCB footprint has been optimized to help reduce design time and simplify the completion of the overall system design.

Device Information⁽¹⁾

Device	Media	Qty	Package	Ship
CSD95372BQ5MC	13-Inch Reel	2500	SON 5 × 6-mm DualCool Package	Tape and Reel
CSD95372BQ5MCT	7-Inch Reel	250		

(1) For all available packages, see the orderable addendum at the end of the data sheet.

Application Diagram

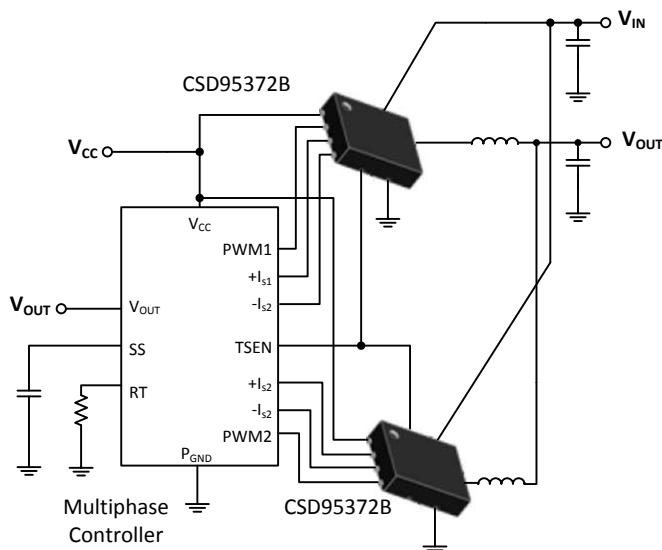

Typical Power Stage Efficiency and Power Loss

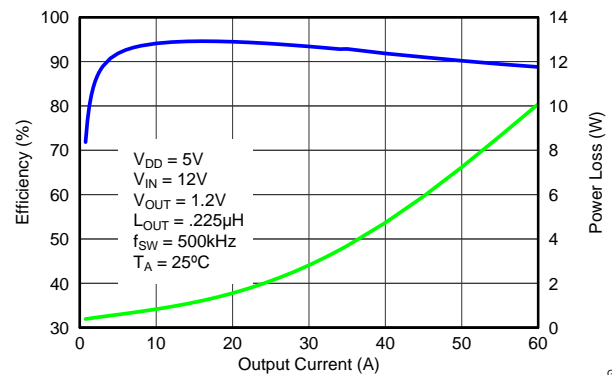

G001



Table of Contents

1 Features	1	7 Application Schematic	5
2 Applications	1	8 Device and Documentation Support	6
3 Description	1	8.1 Trademarks	6
4 Revision History	2	8.2 Electrostatic Discharge Caution	6
5 Pin Configuration and Functions	3	8.3 Glossary	6
6 Specifications	4	9 Mechanical, Packaging, and Orderable Information	7
6.1 Absolute Maximum Ratings	4	9.1 Mechanical Drawing	8
6.2 Handling Ratings	4	9.2 Recommended PCB Land Pattern	9
6.3 Recommended Operating Conditions	4	9.3 Recommended Stencil Opening	9
6.4 Thermal Information	4	9.4 Package Option Addendum	10

4 Revision History

DATE	REVISION	NOTES
April 2014	*	Initial release.

5 Pin Configuration and Functions

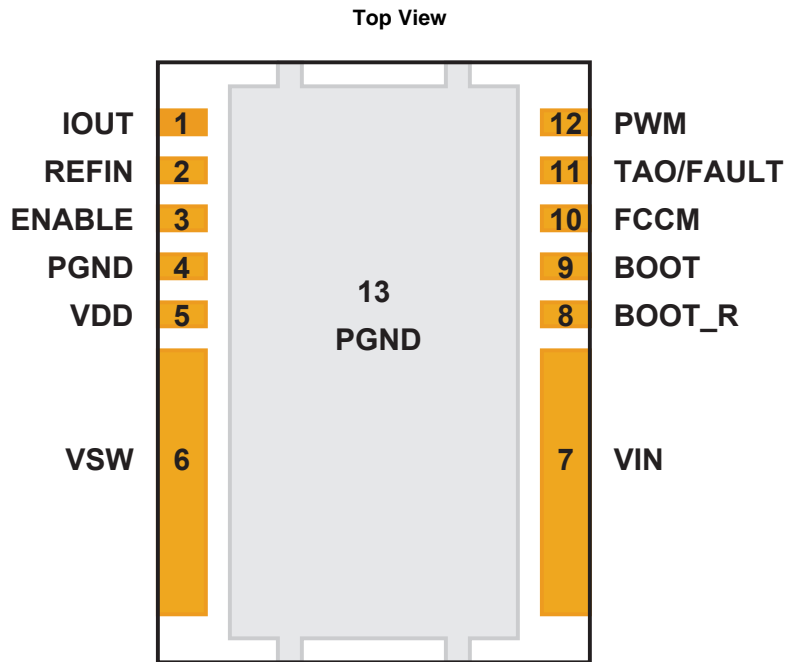

Pin Functions

PIN		DESCRIPTION
NAME	NUMBER	
BOOT	9	Bootstrap capacitor connection. Connect a minimum of 0.1- μ F 16-V X7R ceramic capacitor from BOOT to BOOT_R pins. The bootstrap capacitor provides the charge to turn on the control FET. The bootstrap diode is integrated.
BOOT_R	8	Return path for HS gate driver, connected to V_{SW} internally.
ENABLE	3	Enables device operation. If ENABLE = logic HIGH, turns on device. If ENABLE = logic LOW, the device is turned off and both MOSFET gates are actively pulled low. An internal 100 k Ω pulldown resistor will pull the ENABLE pin LOW if left floating.
FCCM	10	This pin enables the Diode Emulation function. When this pin is held LOW, Diode Emulation Mode is enabled for sync FET. When FCCM is HIGH, the device is operated in Forced Continuous Conduction Mode. An internal 5- μ A current source will pull the FCCM pin to 3.3 V if left floating.
IOUT	1	Output of current sensing amplifier. $V(IOUT) - V(REFIN)$ is proportional to the phase current.
P _{GND}	4	Power ground, connected directly to pin 13.
P _{GND}	13	Power ground
PWM	12	Pulse width modulated 3-state input from external controller. Logic LOW sets control FET gate low and sync FET gate high. Logic HIGH sets control FET gate high and sync FET gate low. Open or High Z sets both MOSFET gates low if greater than the tri-state shutdown hold-off time (t_{3HT}).
REFIN	2	External reference voltage input for current sensing amplifier
TAO/ FAULT	11	Temperature Analog Output. Reports a voltage proportional to the die temperature. An ORing diode is integrated in the IC. When used in multiphase application, a single wire can be used to connect the TAO pins of all the ICs. Only the highest temperature will be reported. TAO will be pulled up to 3.3 V if thermal shutdown occurs. TAO should be bypassed to P _{GND} with a 1-nF 16-V X7R ceramic capacitor.
V _{DD}	5	Supply voltage to gate driver and internal circuitry
V _{IN}	7	Input voltage pin. Connect input capacitors close to this pin.
V _{SW}	6	Phase node connecting the HS MOSFET source and LS MOSFET drain – pin connection to the output inductor.

6 Specifications

6.1 Absolute Maximum Ratings

$T_A = 25^\circ\text{C}$ (unless otherwise noted)⁽¹⁾

PARAMETER	MIN	MAX	UNIT
V_{IN} to P_{GND}	-0.3	25	V
V_{IN} to V_{SW}	-0.3	25	V
V_{IN} to V_{SW} (10 ns)	-7	27	V
V_{SW} to P_{GND}	-0.3	20	V
V_{SW} to P_{GND} (10 ns)	-7	23	V
V_{DD} to P_{GND}	-0.3	7	V
ENABLE, PWM, FCCM, TAO, IOOUT, REFIN to P_{GND}	-0.3	$V_{DD} + 0.3\text{ V}$	V
BOOT to BOOT_R ⁽²⁾	-0.3	$V_{DD} + 0.3\text{ V}$	V
P_D , Power Dissipation		12	W
T_J , Operating Junction	-55	150	$^\circ\text{C}$

(1) Stresses beyond those listed under *absolute maximum ratings* may cause permanent damage to the device. These are stress ratings only, and functional operation of the device at these or any other conditions beyond those indicated is not implied. Exposure to absolute-maximum-rated conditions for extended periods may affect device reliability.

(2) Should not exceed 7 V

6.2 Handling Ratings

PARAMETER	MIN	MAX	UNIT	
T_{stg} Storage Temperature Range	-55	150	$^\circ\text{C}$	
ESD Rating	Human Body Model (HBM)	-2000	2000	V
	Charged Device Model (CDM)	-500	500	

6.3 Recommended Operating Conditions

$T_A = 25^\circ$ (unless otherwise noted)

PARAMETER	CONDITIONS	MIN	MAX	UNIT
V_{DD} Gate Drive Voltage		4.5	5.5	V
V_{IN} Input Supply Voltage ⁽¹⁾			16	V
V_{OUT} Output Voltage			5.5	V
I_{OUT} Continuous Output Current	$V_{IN} = 12\text{ V}$, $V_{DD} = 5\text{ V}$, $V_{OUT} = 3.3\text{ V}$, $f_{SW} = 500\text{ kHz}$, $L_{OUT} = 0.47\text{ }\mu\text{H}$ ⁽²⁾		60	A
I_{OUT-PK} Peak Output Current ⁽³⁾			90	A
f_{SW} Switching Frequency	$C_{BST} = 0.1\text{ }\mu\text{F}$ (min)		1250	kHz
On Time Duty Cycle	$f_{SW} = 1\text{ MHz}$		85	%
Minimum PWM On Time		40		ns
Operating Temperature		-40	125	$^\circ\text{C}$

(1) Operating at high V_{IN} can create excessive AC voltage overshoots on the switch node (V_{SW}) during MOSFET switching transients. For reliable operation, the switch node (V_{SW}) to ground voltage must remain at or below the Absolute Maximum Ratings.

(2) Measurement made with six 10- μF (TDK C3216X5R1C106KT or equivalent) ceramic capacitors placed across V_{IN} to P_{GND} pins.

(3) System conditions as defined in Note 1. Peak Output Current is applied for $t_p = 50\text{ }\mu\text{s}$

6.4 Thermal Information

$T_A = 25^\circ\text{C}$ (unless otherwise noted)

PARAMETER	MIN	TYP	MAX	UNIT
$R_{\theta JC(top)}$ Junction-to-Case (Top of Package) Thermal Resistance ⁽¹⁾			5	$^\circ\text{C/W}$
$R_{\theta JB}$ Junction-to-Board Thermal Resistance ⁽²⁾			1.5	

(1) $R_{\theta JC(top)}$ is determined with the device mounted on a 1-inch² (6.45 -cm²), 2-oz (.071-mm thick) Cu pad on a 1.5-inches x 1.5-inches, 0.06-inch (1.52-mm) thick FR4 board.

(2) $R_{\theta JB}$ value based on hottest board temperature within 1 mm of the package.

7 Application Schematic

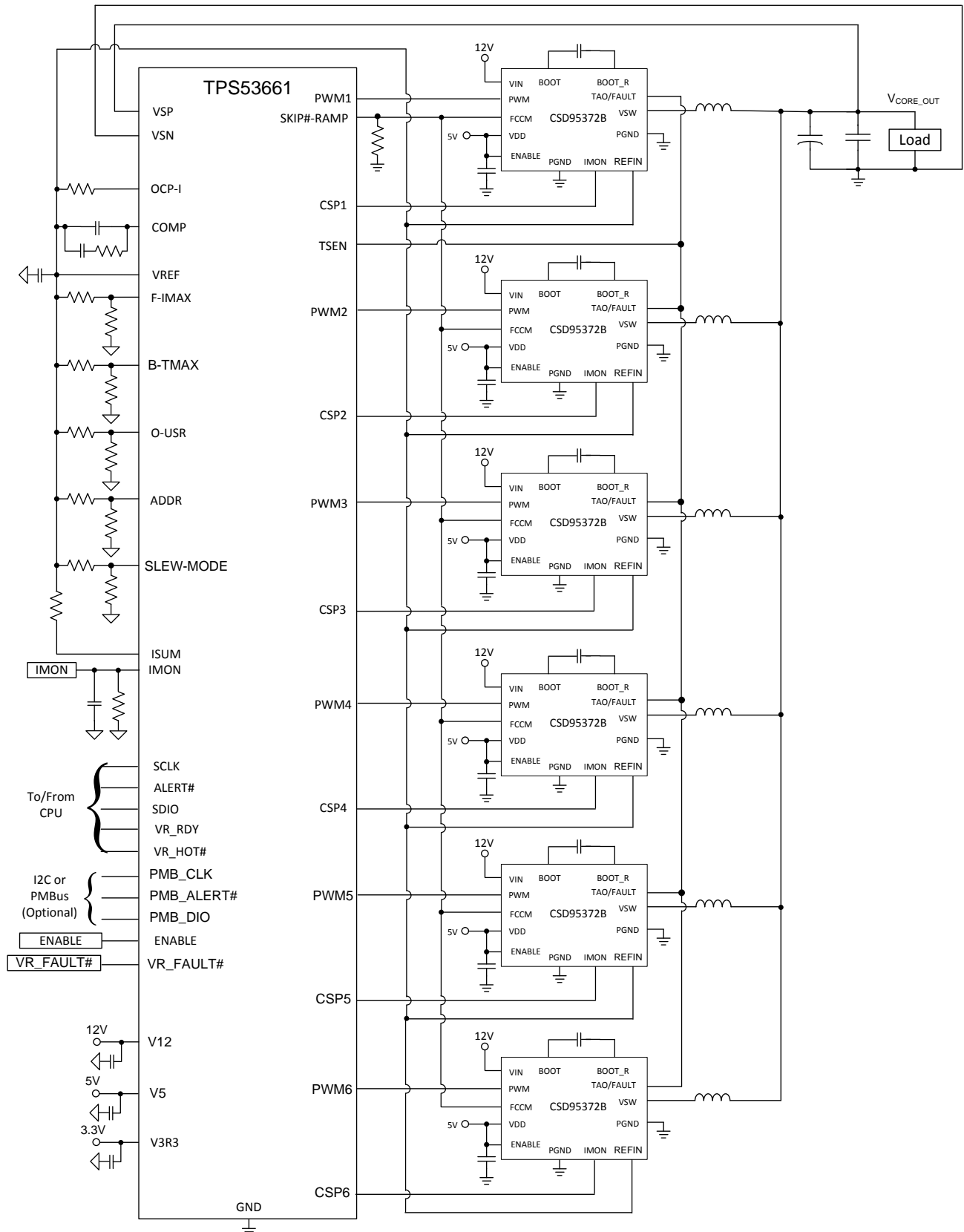

8 Device and Documentation Support

8.1 Trademarks

NexFET, DualCool are trademarks of Texas Instruments.

8.2 Electrostatic Discharge Caution



This integrated circuit can be damaged by ESD. Texas Instruments recommends that all integrated circuits be handled with appropriate precautions. Failure to observe proper handling and installation procedures can cause damage.

ESD damage can range from subtle performance degradation to complete device failure. Precision integrated circuits may be more susceptible to damage because very small parametric changes could cause the device not to meet its published specifications.

8.3 Glossary

[SLYZ022](#) — *TI Glossary*.

This glossary lists and explains terms, acronyms and definitions.

9 Mechanical, Packaging, and Orderable Information

The following pages include mechanical packaging and orderable information. This information is the most current data available for the designated devices. This data is subject to change without notice and revision of this document. For browser-based versions of this data sheet, refer to the left-hand navigation.

9.1 Mechanical Drawing

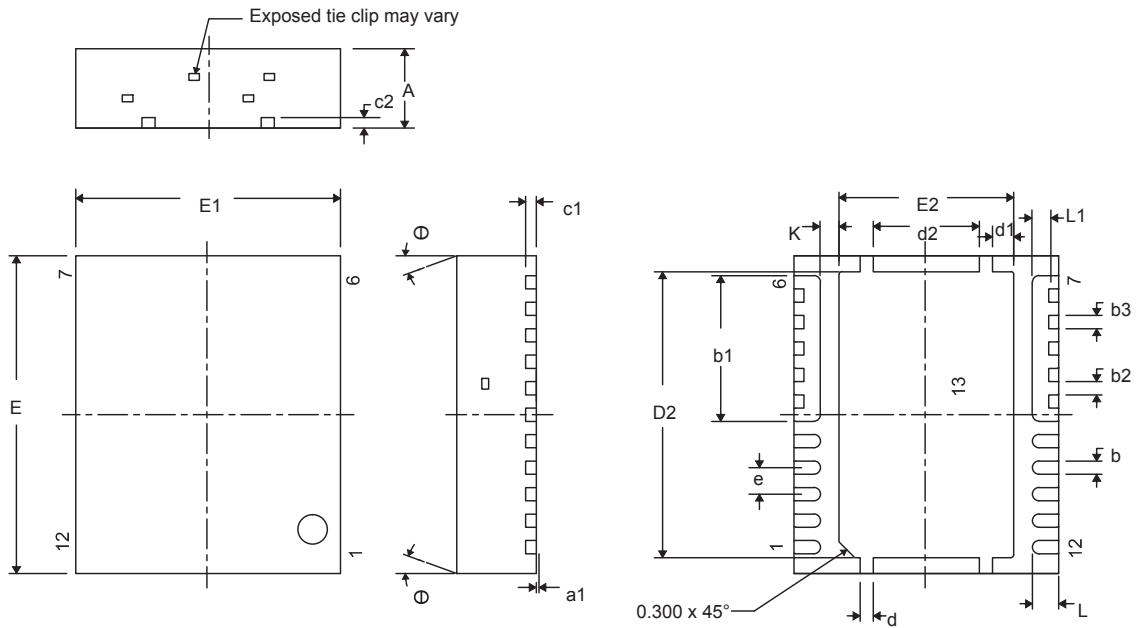

DIM	MILLIMETERS			INCHES		
	Min	Nom	Max	Min	Nom	Max
A	0.950	1.000	1.100	0.037	0.039	0.043
a1	0.000	0.000	0.050	0.000	0.000	0.002
b	0.200	0.250	0.320	0.008	0.010	0.013
b1	2.750 TYP			0.108 TYP		
b2	0.200	0.250	0.320	0.008	0.010	0.013
b3	0.250 TYP			0.010 TYP		
c1	0.150	0.200	0.250	0.006	0.008	0.010
c2	0.200	0.250	0.300	0.008	0.010	0.012
D2	5.300	5.400	5.500	0.209	0.213	0.217
d	0.200	0.250	0.300	0.008	0.010	0.012
d1	0.350	0.400	0.450	0.014	0.016	0.018
d2	1.900	2.000	2.100	0.075	0.079	0.083
E	5.900	6.000	6.100	0.232	0.236	0.240
E1	4.900	5.000	5.100	0.193	0.197	0.201
E2	3.200	3.300	3.400	0.126	0.130	0.134
e	0.500 TYP			0.020 TYP		
K	0.350 TYP			0.014 TYP		
L	0.400	0.500	0.600	0.016	0.020	0.024
L1	0.210	0.310	0.410	0.008	0.012	0.016
θ	0.00	—	—	0.00	—	—

9.2 Recommended PCB Land Pattern

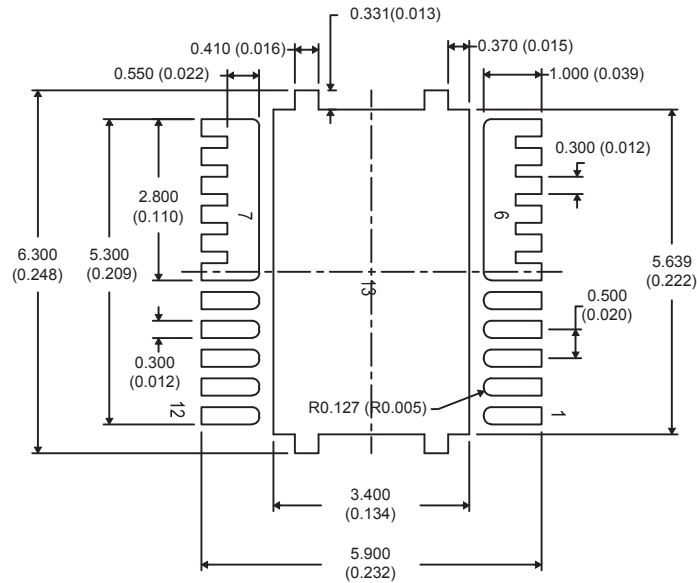

1. Dimensions are in mm (inches).

9.3 Recommended Stencil Opening

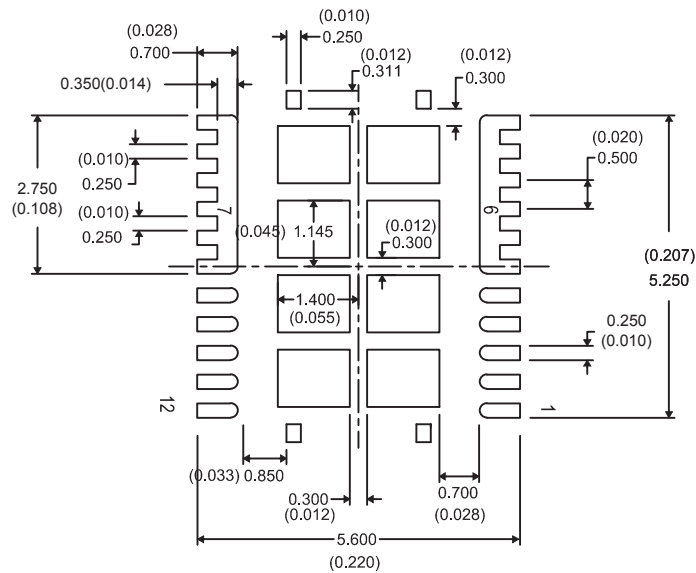

1. Dimensions are in mm (inches).
2. Stencil thickness is 100 μm .

9.4 Package Option Addendum

9.4.1 Packaging Information

Orderable Device	Status ⁽¹⁾	Package Type	Package Drawing	Pins	Package Qty	Eco Plan ⁽²⁾	Lead/Ball Finish	MSL Peak Temp ⁽³⁾	Op Temp (°C)	Device Marking ⁽⁴⁾⁽⁵⁾
CSD95372BQ5MC	Active	SON	DMC	12	2500	PB-Free (RoHS Exempt)	CU NIPDAU	Level-2-260C-1 YEAR	-55 to 150	95372BMC

- (1) The marketing status values are defined as follows:
ACTIVE: Product device recommended for new designs.
LIFEBUY: TI has announced that the device will be discontinued, and a lifetime-buy period is in effect.
NRND: Not recommended for new designs. Device is in production to support existing customers, but TI does not recommend using this part in a new design.
PRE_PROD Unannounced device, not in production, not available for mass market, nor on the web, samples not available.
PREVIEW: Device has been announced but is not in production. Samples may or may not be available.
OBSOLETE: TI has discontinued the production of the device.
- (2) Eco Plan - The planned eco-friendly classification: Pb-Free (RoHS), Pb-Free (RoHS Exempt), or Green (RoHS & no Sb/Br) - please check <http://www.ti.com/productcontent> for the latest availability information and additional product content details.
TBD: The Pb-Free/Green conversion plan has not been defined.
Pb-Free (RoHS): TI's terms "Lead-Free" or "Pb-Free" mean semiconductor products that are compatible with the current RoHS requirements for all 6 substances, including the requirement that lead not exceed 0.1% by weight in homogeneous materials. Where designed to be soldered at high temperatures, TI Pb-Free products are suitable for use in specified lead-free processes.
Pb-Free (RoHS Exempt): This component has a RoHS exemption for either 1) lead-based flip-chip solder bumps used between the die and package, or 2) lead-based die adhesive used between the die and leadframe. The component is otherwise considered Pb-Free (RoHS compatible) as defined above.
Green (RoHS & no Sb/Br): TI defines "Green" to mean Pb-Free (RoHS compatible), and free of Bromine (Br) and Antimony (Sb) based flame retardants (Br or Sb do not exceed 0.1% by weight in homogeneous material)
- (3) MSL, Peak Temp. -- The Moisture Sensitivity Level rating according to the JEDEC industry standard classifications, and peak solder temperature.
- (4) There may be additional marking, which relates to the logo, the lot trace code information, or the environmental category on the device
- (5) Multiple Device markings will be inside parentheses. Only on Device Marking contained in parentheses and separated by a "-" will appear on a device. If a line is indented then it is a continuation of the previous line and the two combined represent the entire Device Marking for that device.

Important Information and Disclaimer: The information provided on this page represents TI's knowledge and belief as of the date that it is provided. TI bases its knowledge and belief on information provided by third parties, and makes no representation or warranty as to the accuracy of such information. Efforts are underway to better integrate information from third parties. TI has taken and continues to take reasonable steps to provide representative and accurate information but may not have conducted destructive testing or chemical analysis on incoming materials and chemicals. TI and TI suppliers consider certain information to be proprietary, and thus CAS numbers and other limited information may not be available for release.

In no event shall TI's liability arising out of such information exceed the total purchase price of the TI part(s) at issue in this document sold by TI to Customer on an annual basis.

9.4.2 Tape and Reel Information

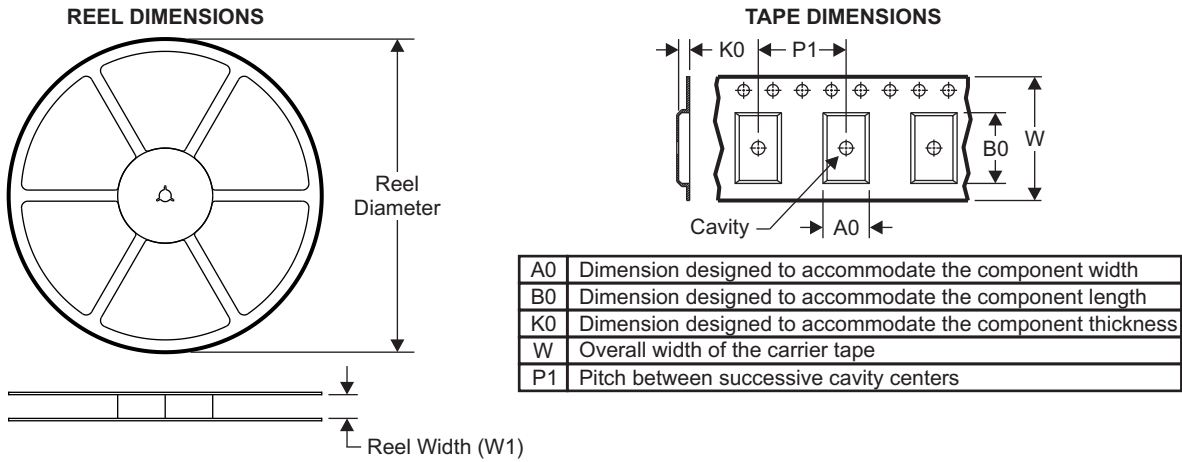

QUADRANT ASSIGNMENTS FOR PIN 1 ORIENTATION IN TAPE

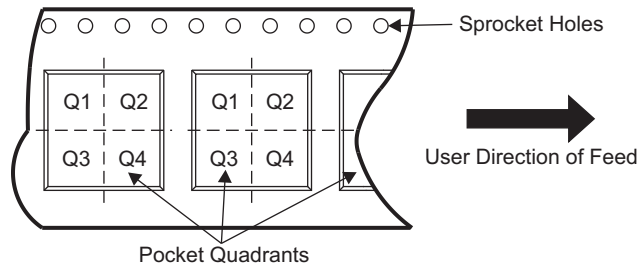

Device	Package Type	Package Drawing	Pins	SPQ	Reel Diameter (mm)	Reel Width W1 (mm)	A0 (mm)	B0 (mm)	K0 (mm)	P1 (mm)	W (mm)	Pin1 Quadrant
CSD95372BQ5MC	SON	DMC	12	2500	330	12.4	5.30	6.30	1.20	8.00	12.00	Q1

PACKAGING INFORMATION

Orderable Device	Status (1)	Package Type	Package Drawing	Pins	Package Qty	Eco Plan (2)	Lead/Ball Finish (6)	MSL Peak Temp (3)	Op Temp (°C)	Device Marking (4/5)	Samples
CSD95372BQ5MC	ACTIVE	VSON-CLIP	DMC	12	2500	Pb-Free (RoHS Exempt)	CU SN	Level-2-260C-1 YEAR	0 to 0	95372BMC	Samples
CSD95372BQ5MCT	ACTIVE	VSON-CLIP	DMC	12	250	Pb-Free (RoHS Exempt)	CU SN Call TI	Level-2-260C-1 YEAR	0 to 0	95372BMC	Samples

(1) The marketing status values are defined as follows:

ACTIVE: Product device recommended for new designs.

LIFEBUY: TI has announced that the device will be discontinued, and a lifetime-buy period is in effect.

NRND: Not recommended for new designs. Device is in production to support existing customers, but TI does not recommend using this part in a new design.

PREVIEW: Device has been announced but is not in production. Samples may or may not be available.

OBSELETE: TI has discontinued the production of the device.

(2) Eco Plan - The planned eco-friendly classification: Pb-Free (RoHS), Pb-Free (RoHS Exempt), or Green (RoHS & no Sb/Br) - please check <http://www.ti.com/productcontent> for the latest availability information and additional product content details.

TBD: The Pb-Free/Green conversion plan has not been defined.

Pb-Free (RoHS): TI's terms "Lead-Free" or "Pb-Free" mean semiconductor products that are compatible with the current RoHS requirements for all 6 substances, including the requirement that lead not exceed 0.1% by weight in homogeneous materials. Where designed to be soldered at high temperatures, TI Pb-Free products are suitable for use in specified lead-free processes.

Pb-Free (RoHS Exempt): This component has a RoHS exemption for either 1) lead-based flip-chip solder bumps used between the die and package, or 2) lead-based die adhesive used between the die and leadframe. The component is otherwise considered Pb-Free (RoHS compatible) as defined above.

Green (RoHS & no Sb/Br): TI defines "Green" to mean Pb-Free (RoHS compatible), and free of Bromine (Br) and Antimony (Sb) based flame retardants (Br or Sb do not exceed 0.1% by weight in homogeneous material)

(3) MSL, Peak Temp. - The Moisture Sensitivity Level rating according to the JEDEC industry standard classifications, and peak solder temperature.

(4) There may be additional marking, which relates to the logo, the lot trace code information, or the environmental category on the device.

(5) Multiple Device Markings will be inside parentheses. Only one Device Marking contained in parentheses and separated by a "~" will appear on a device. If a line is indented then it is a continuation of the previous line and the two combined represent the entire Device Marking for that device.

(6) Lead/Ball Finish - Orderable Devices may have multiple material finish options. Finish options are separated by a vertical ruled line. Lead/Ball Finish values may wrap to two lines if the finish value exceeds the maximum column width.

Important Information and Disclaimer: The information provided on this page represents TI's knowledge and belief as of the date that it is provided. TI bases its knowledge and belief on information provided by third parties, and makes no representation or warranty as to the accuracy of such information. Efforts are underway to better integrate information from third parties. TI has taken and continues to take reasonable steps to provide representative and accurate information but may not have conducted destructive testing or chemical analysis on incoming materials and chemicals. TI and TI suppliers consider certain information to be proprietary, and thus CAS numbers and other limited information may not be available for release.

In no event shall TI's liability arising out of such information exceed the total purchase price of the TI part(s) at issue in this document sold by TI to Customer on an annual basis.

TAPE AND REEL INFORMATION

QUADRANT ASSIGNMENTS FOR PIN 1 ORIENTATION IN TAPE

*All dimensions are nominal

Device	Package Type	Package Drawing	Pins	SPQ	Reel Diameter (mm)	Reel Width W1 (mm)	A0 (mm)	B0 (mm)	K0 (mm)	P1 (mm)	W (mm)	Pin1 Quadrant
CSD95372BQ5MC	VSON-CLIP	DMC	12	2500	330.0	12.4	5.3	6.3	1.2	8.0	12.0	Q1
CSD95372BQ5MCT	VSON-CLIP	DMC	12	250	180.0	12.4	5.3	6.3	1.2	8.0	12.0	Q1

TAPE AND REEL BOX DIMENSIONS

*All dimensions are nominal

Device	Package Type	Package Drawing	Pins	SPQ	Length (mm)	Width (mm)	Height (mm)
CSD95372BQ5MC	VSON-CLIP	DMC	12	2500	367.0	367.0	35.0
CSD95372BQ5MCT	VSON-CLIP	DMC	12	250	210.0	185.0	35.0

IMPORTANT NOTICE

Texas Instruments Incorporated and its subsidiaries (TI) reserve the right to make corrections, enhancements, improvements and other changes to its semiconductor products and services per JESD46, latest issue, and to discontinue any product or service per JESD48, latest issue. Buyers should obtain the latest relevant information before placing orders and should verify that such information is current and complete. All semiconductor products (also referred to herein as "components") are sold subject to TI's terms and conditions of sale supplied at the time of order acknowledgment.

TI warrants performance of its components to the specifications applicable at the time of sale, in accordance with the warranty in TI's terms and conditions of sale of semiconductor products. Testing and other quality control techniques are used to the extent TI deems necessary to support this warranty. Except where mandated by applicable law, testing of all parameters of each component is not necessarily performed.

TI assumes no liability for applications assistance or the design of Buyers' products. Buyers are responsible for their products and applications using TI components. To minimize the risks associated with Buyers' products and applications, Buyers should provide adequate design and operating safeguards.

TI does not warrant or represent that any license, either express or implied, is granted under any patent right, copyright, mask work right, or other intellectual property right relating to any combination, machine, or process in which TI components or services are used. Information published by TI regarding third-party products or services does not constitute a license to use such products or services or a warranty or endorsement thereof. Use of such information may require a license from a third party under the patents or other intellectual property of the third party, or a license from TI under the patents or other intellectual property of TI.

Reproduction of significant portions of TI information in TI data books or data sheets is permissible only if reproduction is without alteration and is accompanied by all associated warranties, conditions, limitations, and notices. TI is not responsible or liable for such altered documentation. Information of third parties may be subject to additional restrictions.

Resale of TI components or services with statements different from or beyond the parameters stated by TI for that component or service voids all express and any implied warranties for the associated TI component or service and is an unfair and deceptive business practice. TI is not responsible or liable for any such statements.

Buyer acknowledges and agrees that it is solely responsible for compliance with all legal, regulatory and safety-related requirements concerning its products, and any use of TI components in its applications, notwithstanding any applications-related information or support that may be provided by TI. Buyer represents and agrees that it has all the necessary expertise to create and implement safeguards which anticipate dangerous consequences of failures, monitor failures and their consequences, lessen the likelihood of failures that might cause harm and take appropriate remedial actions. Buyer will fully indemnify TI and its representatives against any damages arising out of the use of any TI components in safety-critical applications.

In some cases, TI components may be promoted specifically to facilitate safety-related applications. With such components, TI's goal is to help enable customers to design and create their own end-product solutions that meet applicable functional safety standards and requirements. Nonetheless, such components are subject to these terms.

No TI components are authorized for use in FDA Class III (or similar life-critical medical equipment) unless authorized officers of the parties have executed a special agreement specifically governing such use.

Only those TI components which TI has specifically designated as military grade or "enhanced plastic" are designed and intended for use in military/aerospace applications or environments. Buyer acknowledges and agrees that any military or aerospace use of TI components which have **not** been so designated is solely at the Buyer's risk, and that Buyer is solely responsible for compliance with all legal and regulatory requirements in connection with such use.

TI has specifically designated certain components as meeting ISO/TS16949 requirements, mainly for automotive use. In any case of use of non-designated products, TI will not be responsible for any failure to meet ISO/TS16949.

Products

Audio	www.ti.com/audio
Amplifiers	amplifier.ti.com
Data Converters	dataconverter.ti.com
DLP® Products	www.dlp.com
DSP	dsp.ti.com
Clocks and Timers	www.ti.com/clocks
Interface	interface.ti.com
Logic	logic.ti.com
Power Mgmt	power.ti.com
Microcontrollers	microcontroller.ti.com
RFID	www.ti-rfid.com
OMAP Applications Processors	www.ti.com/omap
Wireless Connectivity	www.ti.com/wirelessconnectivity

Applications

Automotive and Transportation	www.ti.com/automotive
Communications and Telecom	www.ti.com/communications
Computers and Peripherals	www.ti.com/computers
Consumer Electronics	www.ti.com/consumer-apps
Energy and Lighting	www.ti.com/energy
Industrial	www.ti.com/industrial
Medical	www.ti.com/medical
Security	www.ti.com/security
Space, Avionics and Defense	www.ti.com/space-avionics-defense
Video and Imaging	www.ti.com/video

TI E2E Community

e2e.ti.com