

CMOS Serial Real-Time Clock With RAM and Power Sense/Control

The CDP68HC68T1 Real-Time Clock provides a time/calendar function, a 32 byte static RAM, and a 3 wire Serial Peripheral Interface (SPI Bus). The primary function of the clock is to divide down a frequency input that can be supplied by the on-board oscillator in conjunction with an external crystal or by an external clock source. The internal oscillator can operate with a 32kHz, 1MHz, 2MHz, or 4MHz crystal. An external clock source with a 32kHz, 1MHz, 2MHz, 4MHz, 50Hz or 60Hz frequency can be used to drive the CDP68HC68T1. The time registers hold seconds, minutes, and hours, while the calendar registers hold day-of-week, date, month, and year information. The data is stored in BCD format. In addition, 12 or 24 hour operation can be selected. In 12 hour mode, an AM/PM indicator is provided. The T1 has a programmable output which can provide one of seven outputs for use elsewhere in the system.

Computer handshaking is controlled with a "wired-OR" interrupt output. The interrupt can be programmed to provide a signal as the result of:

1. An alarm programmed to occur at a predetermined combination of seconds, minutes, and hours.
2. One of 15 periodic interrupts ranging from sub-second to once per day frequency.
3. A power fail detect. The PSE output and the V_{SYS} input are used for external power control. The CPUR output is available to reset the processor under power-down conditions. CPUR is enabled under software control and can also be activated via the CDP68HC68T1's watchdog. If enabled, the watchdog requires a periodic toggle of the CE pin without a serial transfer.

Features

- SPI (Serial Peripheral Interface)
- Full Clock Features
 - Seconds, Minutes, Hours (12/24, AM/PM), Day of Week, Date, Month, Year (0 to 99), Automatic Leap Year
- 32 Wordx8-Bit RAM
- Seconds, Minutes, Hours Alarm
- Automatic Power Loss Detection
- Low Minimum Standby (Timekeeping) Voltage 2.2V
- Selectable Crystal or 50/60Hz Line Input
- Buffered Clock Output
- Battery Input Pin that Powers Oscillator and also Connects to V_{DD} Pin When Power Fails
- Three Independent Interrupt Modes
 - Alarm
 - Periodic
 - Power-Down Sense
- Pb-Free Available (RoHS Compliant)

Pinouts

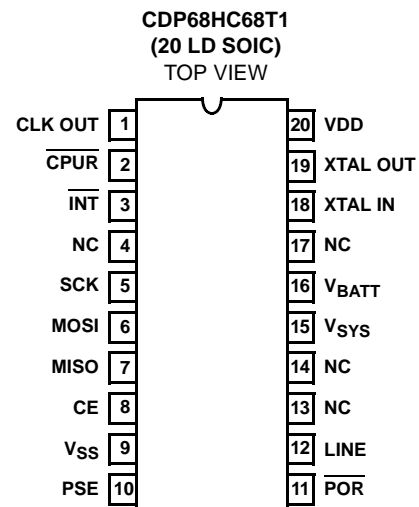
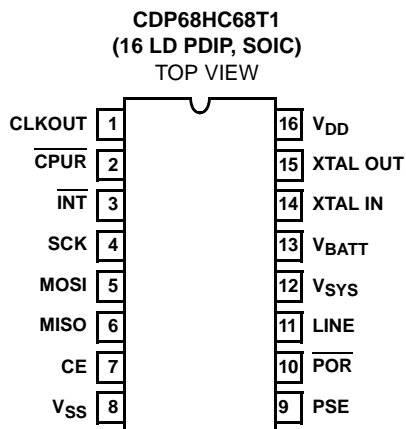

CDP68HC68T1

Ordering Information

PART NUMBER	PART MARKING	TEMP RANGE (°C)	PACKAGE	PKG DWG. #
CDP68HC68T1E	CDP68HC68T1E	-40 to +85	16 Ld PDIP	E16.3
CDP68HC68T1EZ (Note)	CDP68HC68T1EZ	-40 to +85	16 Ld PDIP** (Pb-free)	E16.3
CDP68HC68T1M*	68HC68T1M	-40 to +85	20 Ld SOIC Tape and Reel	M20.3
CDP68HC68T1MZ* (Note)	68HC68T1MZ	-40 to +85	20 Ld SOIC (Pb-free) Tape and Reel	M20.3
CDP68HC68T1M2*	HC68T1M2	-40 to +85	16 Ld SOIC Tape and Reel	M16.3
CDP68HC68T1M2Z* (Note)	HC68T1M2Z	-40 to +85	16 Ld SOIC (Pb-free) Tape and Reel	M16.3

*Add "96" suffix for tape and reel. Please refer to TB347 for details on reel specifications.

**Pb-free PDIPs can be used for through hole wave solder processing only. They are not intended for use in Reflow solder processing applications.

NOTE: These Intersil Pb-free plastic packaged products employ special Pb-free material sets; molding compounds/die attach materials and 100% matte tin plate PLUS ANNEAL - e3 termination finish, which is RoHS compliant and compatible with both SnPb and Pb-free soldering operations. Intersil Pb-free products are MSL classified at Pb-free peak reflow temperatures that meet or exceed the Pb-free requirements of IPC/JEDEC J STD-020.

CDP68HC68T1

Absolute Maximum Ratings

Supply Voltage (V_{DD}) -0.5V to +7V
 Input Voltage (V_{IN}) V_{SS} -0.3V to V_{DD} +0.3V
 Current Drain Per Input Pin (Excluding V_{DD} and V_{SS} I) 10mA
 Current Drain Per Output Pin I 40mA

Operating Conditions

Voltage Range +3.0V to +6.0V
 Standby (Timekeeping) Voltage +2.2V to +6.0V
 Temperature Range
 CDP68HC68T1E (PDIP Package) -40°C to +85°C
 CDP68HC68T1M/M2 (SOIC Packages) -40°C to +85°C
 Input Voltage
 Input High (0.7 x V_{DD}) to V_{DD}
 Input Low 0V to (0.3 x V_{DD})
 Serial Clock Frequency (f_{SCK}) +3.0V to +6.0V

Thermal Information

Thermal Resistance (Typical, Note 1) θ_{JA} (°C/W)
 16 Ld PDIP* 90
 16 Ld SOIC 100
 20 Ld SOIC 95

Maximum Junction Temperature (Plastic) +150°C
 Maximum Storage Temperature Range (T_{STG}) -65°C to +150°C
 Pb-free reflow profile see link below
<http://www.intersil.com/pbfree/Pb-FreeReflow.asp>

*Pb-free PDIPs can be used for through hole wave solder processing only. They are not intended for use in Reflow solder processing applications.

CAUTION: Do not operate at or near the maximum ratings listed for extended periods of time. Exposure to such conditions may adversely impact product reliability and result in failures not covered by warranty.

NOTE:

- θ_{JA} is measured with the component mounted on a low effective thermal conductivity test board in free air. See Tech Brief TB379 for details.

Static Electrical Specifications At $T_A = -40^\circ\text{C}$ to $+85^\circ\text{C}$, $V_{DD} = V_{BATT} = 5V \pm 5\%$, Unless Otherwise Specified.

PARAMETER	SYMBOL	TEST CONDITIONS	CDP68HC68T1			UNITS
			MIN	TYP (Note 2)	MAX	
Quiescent Device Current	I_{DD}		-	1	10	μA
Output Voltage High Level	V_{OH}	$I_{OH} = -1.6\text{mA}$, $V_{DD} = 4.5\text{V}$	3.7	-	-	V
Output Voltage Low Level	V_{OL}	$I_{OL} = 1.6\text{mA}$, $V_{DD} = 4.5\text{V}$	-	-	0.4	V
Output Voltage High Level	V_{OH}	$I_{OH} \leq 10\mu\text{A}$, $V_{DD} = 4.5\text{V}$	4.4	-	-	V
Output Voltage Low Level	V_{OL}	$I_{OL} \leq 10\mu\text{A}$, $V_{DD} = 4.5\text{V}$	-	-	0.1	V
Input Leakage Current	I_{IN}		-	-	± 1	μA
Three-State Output Leakage Current	I_{OUT}		-	-	± 10	μA
Operating Current (Note 3) ($I_D + I_B$) $V_{DD} = V_B = 5\text{V}$ Crystal Operation		32kHz	-	0.08	-	mA
		1MHz	-	0.5	-	mA
		2MHz	-	0.7	-	mA
		4MHz	-	1	-	mA
XTAL IN Clock (Squarewave) (Note 3) ($I_D + I_B$) $V_{DD} = V_S = 5\text{V}$		32kHz	-	0.02	0.024	mA
		1MHz	-	0.1	0.12	mA
		2MHz	-	0.2	0.24	mA
		4MHz	-	0.4	0.5	mA
Standby Current (Note 3) $V_S = 3\text{V}$ Crystal Operation	I_B	32kHz	-	20	-	μA
		1MHz	-	200	-	μA
		2MHz	-	300	-	μA
		4MHz	-	500	-	μA

CDP68HC68T1

Static Electrical Specifications At $T_A = -40^\circ\text{C}$ to $+85^\circ\text{C}$, $V_{DD} = V_{BATT} = 5\text{V} \pm 5\%$, Unless Otherwise Specified. (Continued)

PARAMETER	SYMBOL	TEST CONDITIONS	CDP68HC68T1			UNITS	
			MIN	TYP (Note 2)	MAX		
Operating Current (Note 3) $V_{DD} = 5\text{V}$, $V_B = 3\text{V}$ Crystal Operation				I_D	I_B	-	mA
		32kHz	-	0.025	0.015	-	mA
		1MHz	-	0.08	0.15	-	mA
		2MHz	-	0.15	0.25	-	mA
		4MHz	-	0.3	0.4	-	mA
Standby Current (Note 3) $V_B = 2.2\text{V}$ Crystal Operation	I_B	32kHz	-	10	-	-	μA
Input Capacitance	C_{IN}	$V_{IN} = 0$, $T_A = +25^\circ\text{C}$	-	-	2	-	pF
Maximum Rise and Fall Times (Except XTAL Input and $\overline{\text{POR}}$ Pin 10)	t_r , t_f		-	-	2	-	μs
					-	-	μs
Input Voltage (Line Input Pin Only, Power Sense Mode)			0	10	12	-	V
$V_{SYS} > V_{BVT}$ (For V_B Not Internally Connected to V_{DD})			-	1.0	-	-	V
Power-On Reset ($\overline{\text{POR}}$) Pulse Width			100	75	-	-	ns

NOTES:

2. Typical values are for $T_A = +25^\circ\text{C}$ and nominal V_{DD} .
3. Clock out (Pin 1) disabled, outputs open circuited. No serial access cycles.

Dynamic Electrical Specifications Bus Timing $V_{DD} \pm 10\%$, $V_{SS} = 0V_{DC}$, $T_A = -40^\circ\text{C}$ to $+85^\circ\text{C}$

IDENTIFICATION NUMBER	PARAMETER	SYMBOL	LIMITS (ALL TYPES)				UNITS
			$V_{DD} = 3.3\text{V}$		$V_{DD} = 5\text{V}$		
			MIN	MAX	MIN	MAX	
1	Chip Enable Setup Time	t_{EVCV}	200	-	100	-	ns
2	Chip Enable After Clock Hold Time	t_{CVEX}	250	-	125	-	ns
3	Clock Width High	t_{WH}	400	-	200	-	ns
4	Clock Width Low	t_{WL}	400	-	200	-	ns
5	Data In to Clock Setup Time	t_{DVCV}	200	-	100	-	ns
7	Clock to Data Propagation Delay	t_{CVDV}	-	200	-	100	ns
8	Chip Disable to Output High Z	t_{EXQZ}	-	200	-	100	ns
11	Output Rise Time	t_r	-	200	-	100	ns
12	Output Fall Time	t_f	-	200	-	100	ns
A	Data in After Clock Hold Time	t_{CVDX}	200	-	100	-	ns
B	Clock to Data Out Active	t_{CVQX}	-	200	-	100	ns
C	Clock Recovery Time	t_{REC}	200	-	200	-	ns

Functional Block Diagram

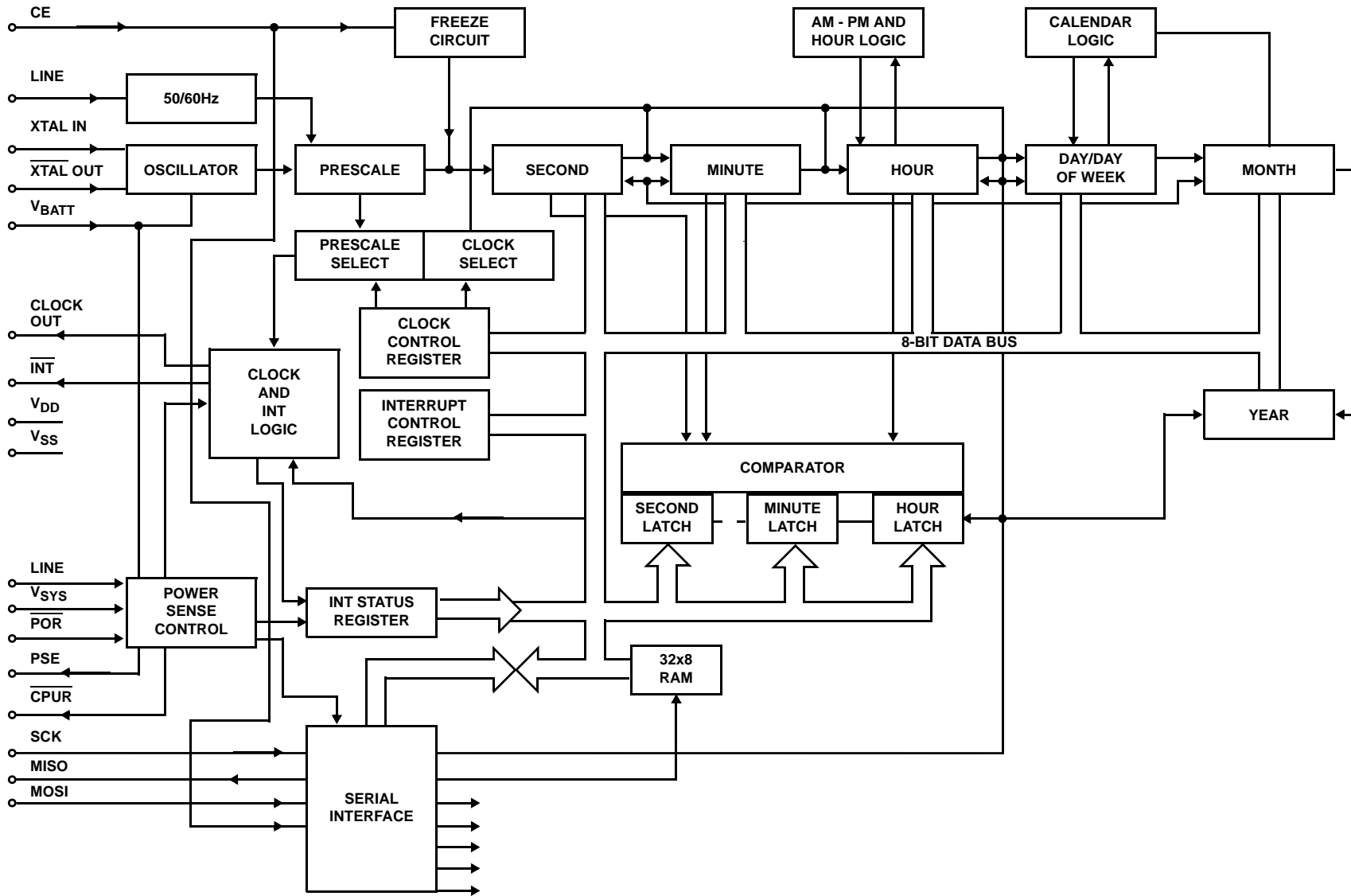

FIGURE 1. REAL TIME CLOCK FUNCTIONAL DIAGRAM

CDP68HC68T1

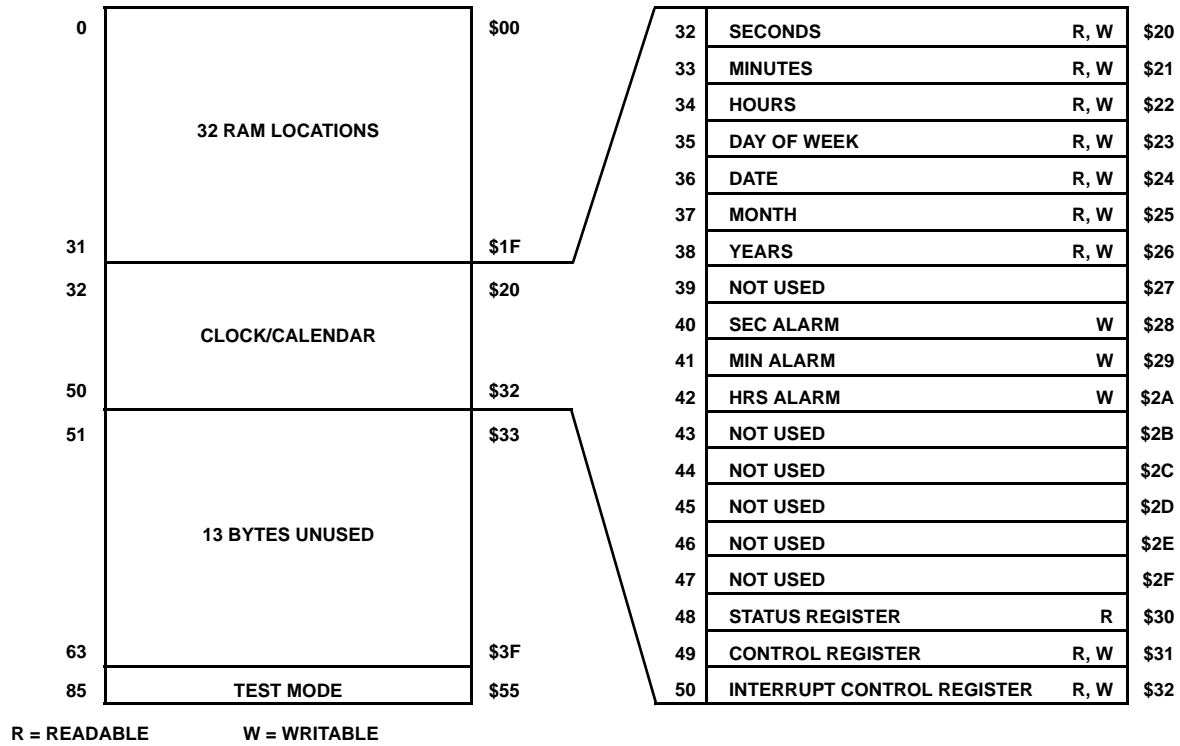

FIGURE 2. ADDRESS MAP

TABLE 1. CLOCK/CALENDAR AND ALARM DATA MODES

ADDRESS LOCATION (H)	FUNCTION	DECIMAL RANGE	BCD DATA RANGE	BCD DATE EXAMPLE (Note 4)
20	Seconds	0 to 59	00 to 59	18
21	Minutes	0 to 59	00 to 59	49
22	Hours 12 Hour Mode (Note 5)	1 to 12	81 to 92 (AM) A1 to B2 (PM)	A3
	Hours 24 Hour Mode	0 to 23	00 to 23	15
23	Day of the Week (Sunday = 1)	1 to 7	01 to 07	03
24	Day of the Month (Date)	1 to 31	01 to 31	29
25	Month Jan = 1, Dec = 12	1 to 12	01 to 12	10
26	Years	0 to 99	00 to 99	85
28	Alarm Seconds	0 to 59	00 to 59	18
29	Alarm Minutes	0 to 59	00 to 59	49
2A	Alarm Hours (Note 6) 12 Hour Mode	1 to 12	01 to 12 (AM) 21 to 32 (PM)	23
	Alarm Hours 24 Hour Mode	0 to 23	00 to 23	15

NOTES:

4. Example: 3:49:18, Tuesday, Oct. 29, 1985.
5. Most significant Bit, D7, is "0" for 24 hours, and "1" for 12 hour mode. Data Bit D5 is "1" for PM and "0" for AM in 12 hour mode.
6. Alarm hours. Data Bit D5 is "1" for PM and "0" for AM in 12 hour mode. Data Bits D7 and D6 are DON'T CARE.

Programmers Model - Clock Registers

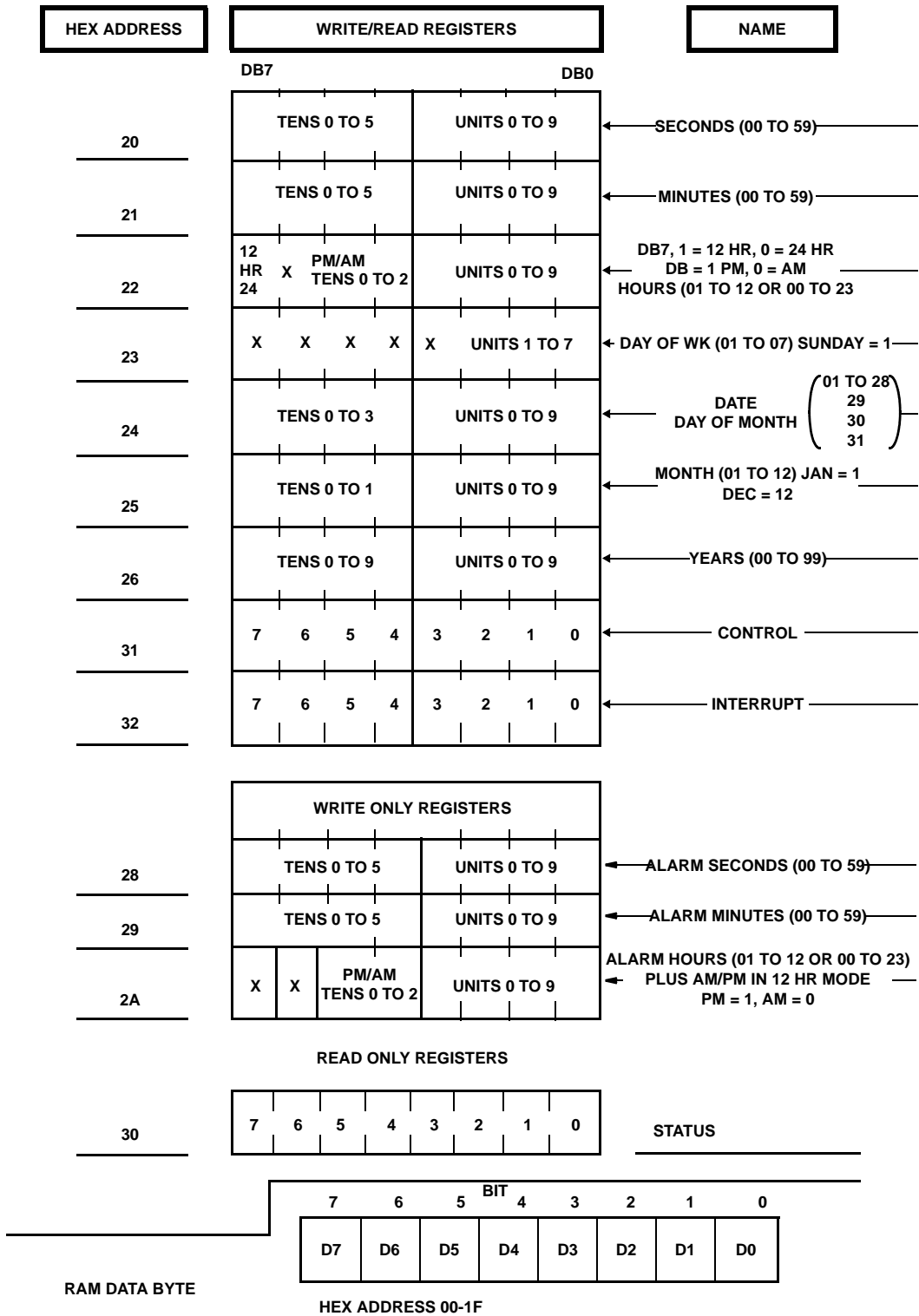

NOTE: X = Don't care writes, X = 0 when read.

Functional Description

The SPI real-time clock consists of a clock/calendar and a 32x8 RAM. Communications is established via the SPI (Serial Peripheral Interface) bus. In addition to the clock/calendar data from seconds to years, and system flexibility provided by the 32-byte RAM, the clock features computer handshaking with an interrupt output and a separate squarewave clock output that can be one of seven different frequencies. An alarm circuit is available that compares the alarm latches with the seconds, minutes and hours time counters and activates the interrupt output when they are equal. The clock is specifically designed to aid in power-down/power-up applications and offers several pins to aid the designer of battery backup systems.

Mode Select

The voltage level that is present at the V_{SYS} input pin at the end of power-on-reset selects the device to be in the single supply or battery backup mode.

Single-Supply Mode

If V_{SYS} is a logic high when power-on-reset is completed, CLK OUT, PSE and \overline{CPUR} will be enabled and the device will be completely operational. \overline{CPUR} will be placed low if the logic level at the V_{SYS} pin goes low. If the output signals CLK OUT, PSE and \overline{CPUR} are disabled due to a power-down instruction, V_{SYS} brought to a logic low and then to a logic high will re-enable these outputs. An example of the single-supply mode is where only one supply is available and V_{DD} , V_{BATT} and V_{SYS} are tied together to the supply.

Battery Backup Mode

If V_{SYS} is a logic low at the end of power-on-reset, CLK OUT, PSE and \overline{CPUR} will be disabled (CLK OUT, PSE and \overline{CPUR} low). This condition will be held until V_{SYS} rises to a threshold (about 1.0V) above V_{BATT} . The outputs CLK OUT, PSE and \overline{CPUR} will then be enabled and the device will be operational. If V_{SYS} falls below a threshold above V_{BATT} the outputs CLK OUT, PSE and \overline{CPUR} will be disabled. An example of battery backup operation occurs if V_{SYS} is tied to V_{DD} and V_{DD} is not connected to a supply when a battery is connected to the V_{BATT} pin. (See "Functional Description", V_{BATT} for Battery Backup Operation on page 11.)

Clock/Calendar (See Figures 1 and 2)

The clock/calendar portion of this device consists of a long string of counters that is toggled by a 1Hz input. The 1Hz input is generated by a prescaler driven by an on-board oscillator that utilizes one of four possible external crystals or that can be driven by an external clock source. The 1Hz trigger to the counters can also be supplied by a 50Hz or 60Hz input source that is connected to the LINE input pin.

The time counters offer seconds, minutes and hours data in 12 hour or 24 hour format. An AM/PM indicator is available that once set, toggles every 12 hours. The calendar counters consist of day (day of week), date (day of month), month and

years information. Data in the counters is in BCD format. The hours counter utilizes BCD for hour data plus bits for 12/24 hour and AM/PM. The seven time counters are accessed serially at addresses 20H through 26H. See Table 1.

RAM

The real-time clock also has a static 32x8 RAM that is located at addresses 00-1FH. Transmitting the address/control word with Bit 5 low selects RAM access. Bits 0 through 4 select the RAM location.

Alarm

The alarm is set by accessing the three alarm latches and loading the required data. The alarm latches consist of seconds, minutes and hours registers. When their outputs equal the values in the seconds, minutes and hours time counters, an interrupt is generated. The interrupt output will go low if the alarm bit in the Interrupt Control Register is set high. The alarm interrupt bit in the Status Register is set when the interrupt occurs (see "Functional Description", INT Pin on page 10). To preclude a false interrupt when loading the time counters, the alarm interrupt bit should be set low in the Interrupt Control Register. This procedure is not required when the alarm time is set.

Watchdog Function (See Figure 6)

When Bit 7 in the Interrupt Control Register is set high, the Clock's CE (chip enable) pin must be toggled at a regular interval without a serial data transfer. If the CE is not toggled, the clock will supply a CPU reset pulse and Bit 6 in the Status Register will be set. Typical service and reset times are listed in Table 2.

TABLE 2.

	50Hz		60Hz		XTAL	
	MIN	MAX	MIN	MAX	MIN	MAX
Service Time	-	10ms	-	8.3ms	-	7.8ms
Reset Time	20	40ms	16.7	33.3ms	15.6	31.3ms

Clock Out

The value in the three least significant bits of the Clock Control Register selects one of seven possible output frequencies. (See "Clock Control Register" on page 11). This squarewave signal is available at the CLK OUT pin. When power-down operation is initiated, the output is set low.

Control Registers and Status Registers

The operation of the Real-Time Clock is controlled by the Clock Control and Interrupt Control Registers. Both registers are Read-Write Registers. Another register, the Status Register, is available to indicate the operating conditions. The Status Register is a Read only Register.

Power Control

Power control is composed of two operations, Power Sense and Power-Down/Power-Up. Two pins are involved in power sensing, the LINE input pin and the INT output pin. Two additional pins are utilized during power-down/power-up operation. They are the PSE (Power Supply Enable) output pin and V_{SYS} input pin.

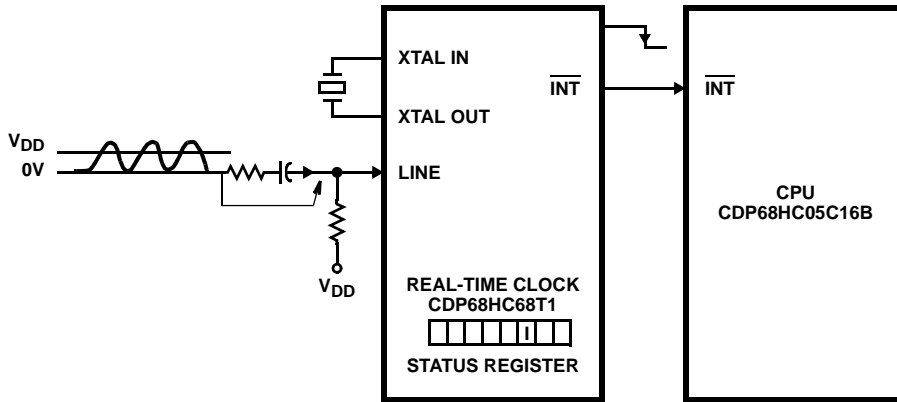

FIGURE 3. POWER-SENSING FUNCTIONAL DIAGRAM

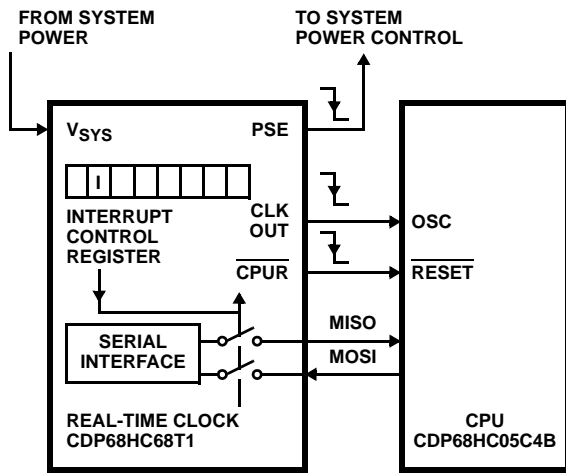

FIGURE 4. POWER-DOWN FUNCTIONAL DIAGRAM

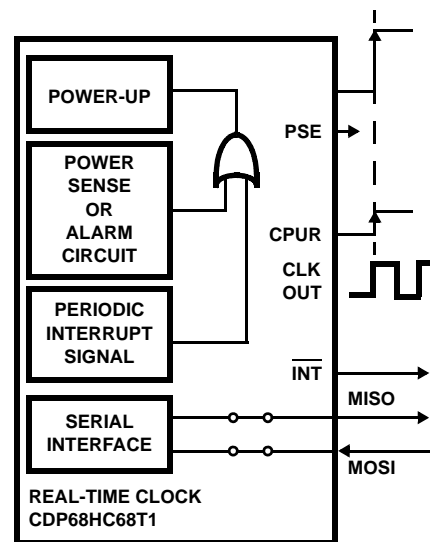

FIGURE 5. POWER-UP FUNCTIONAL DIAGRAM (INITIATED BY INTERRUPT SIGNAL)

Power Sensing (See Figure 3)

When Power Sensing is enabled (Bit 5 = 1 in Interrupt Control Register), AC transitions are sensed at the LINE input pin. Threshold detectors determine when transitions cease. After a delay of 2.68ms to 4.64ms, plus the external input circuit RC time constant, an interrupt is generated and a bit is set in the Status Register. This bit can then be sampled to see if system power has turned back on. See "Functional Description", Line pin on page 10. The power-sense circuitry operates by sensing the level of the voltage presented at the line input pin. This voltage is centered around V_{DD} and as long as it is either plus or minus a threshold (about 1V) from V_{DD} a power-sense failure will not be indicated. With an AC signal present, remaining in this V_{DD} window longer than a minimum of 2.68ms will activate the power-sense circuit. The larger the amplitude of the AC signal, the less time it spends in the V_{DD} window, and the less likely a power failure will be detected. A 60Hz, 10V_{p-p} sinewave voltage is an applicable

signal to present at the LINE input pin to setup the power sense function.

Power-Down (See Figure 4)

Power-down is a processor-directed operation. A bit is set in the Interrupt Control Register to initiate operation. Three pins are affected. The PSE (Power Supply Enable) output, normally high, is placed low. The CLK OUT is placed low. The CPUR output, connected to the processors reset input is also placed low. In addition, the Serial Interface is disabled.

Power-Up (See Figures 5 and 6)

Two conditions will terminate the Power-Down mode.

1. The first condition (see Figure 5) requires an interrupt. The interrupt can be generated by the alarm circuit, the programmable periodic interrupt signal, or the power sense circuit.

- The second condition that releases Power-Down occurs when the level on the V_{SYS} pin rises about 1.0V above the level at the V_{BATT} input, after previously falling to the level of V_{BATT} (see Figure 6) in the Battery Backup Mode or V_{SYS} falls to logic low and returns high in the Single Supply Mode.

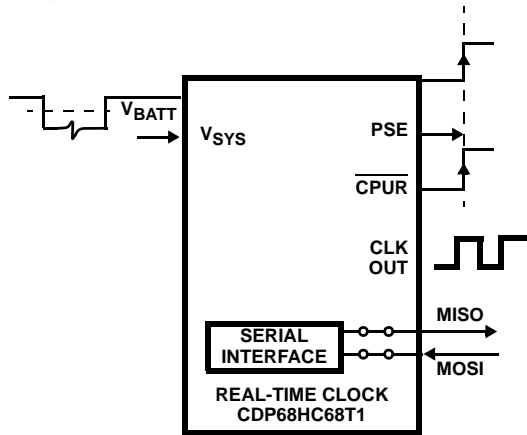

FIGURE 6. POWER-UP FUNCTIONAL DIAGRAM (INITIATED BY A RISE IN VOLTAGE ON THE “ V_{SYS} ” PIN)

CLK OUT

Clock output pin. One of seven frequencies can be selected (or this output can be set low) by the levels of the three LSB’s in the Clock-Control Register. If a frequency is selected, it will toggle with a 50% duty cycle except 2Hz in the 50Hz time base mode. (e.g. if 1Hz is selected, the output will be high for 500ms and low for the same period). During power-down operation (Bit 6 in Interrupt Control Register is set to “1”), the clock-output pin will be set low.

CPU_R

CPU reset output pin. This pin functions as an N-Channel only, open-drain output and requires an external pull-up resistor.

INT

Interrupt output pin. This output is driven from a single NFET pulldown transistor and must be tied to an external pull-up resistor. The output is activated to a low level when:

- Power-sense operation is selected (B5 = 1 in Interrupt Control Register) and a power failure occurs.
- A previously set alarm time occurs. The alarm bit in the Status Register and interrupt-out signal are delayed 30.5µs when 32kHz operation is selected and 15.3µs for 2MHz and 7.6µs for 4MHz.
- A previously selected periodic interrupt signal activates.

The Status Register must be read to set the Interrupt output high after the selected periodic interval occurs. This is also true when conditions 1 and 2 activate the interrupt. If power-down had been previously selected, the interrupt will also reset the power-down functions.

SCK, MOSI, MISO

See “Serial Peripheral Interface (SPI)” on page 8.

CE

A positive chip-enable input. A low level at this input holds the serial interface logic in a reset state. This pin is also used for the watchdog function.

VSS

The negative power-supply pin that is connected to ground.

PSE

Power-supply enable output pin. This pin is used to control power to the system. The pin is set high when:

- V_{SYS} rises above the V_{BATT} voltage after V_{SYS} was placed low by a system failure.
- An interrupt occurs.
- A power-on reset (if V_{SYS} is a logic high).

The PSE pin is set low by writing a high into bit 6 (power-down bit) in the Interrupt Control Register.

POR

Power-on reset. A Schmitt-trigger input that generates a power-on internal reset signal using an external RC network. Both control registers and frequency dividers for the oscillator and line input are reset. The Status Register is reset except for the first time up bit (B4), which is set. Single supply or battery backup operation is selected at the end of POR.

LINE

This input is used for two functions. When not used it should be connected to V_{DD} via a 10kΩ resistor. The first function utilizes the input signal as the frequency source for the timekeeping counters. This function is selected by setting Bit 6 in the Clock Control Register. The second function enables the line input to sense a power failure. Threshold detectors operating above and below V_{DD} sense an AC voltage loss. Bit 5 must be set to “1” in the Interrupt Control Register and crystal or external clock source operation is required. Bit 6 in the Clock Control Register must be low to select XTAL operation.

Oscillator Circuit

The CDP68HC68T1 has an on-board 150kΩ resistor that is switched in series with its internal inverter when 32kHz is selected via the Clock Control Register. Note: When first powered up the series resistor is not part of the oscillator circuit. (The CDP68HC68T1 sets up for a 4MHz oscillator).

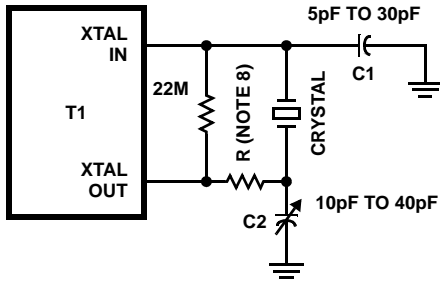

NOTES:

- 7. All frequencies recommended oscillator circuit. C₁, C₂ values crystal dependent.
- 8. R is used for 32KHz operation only. 100k to 300k range as specified by crystal manufacturer.

FIGURE 7. OSCILLATOR CIRCUIT

V_{sys}

This input is connected to the system voltage. After the CPU initiates power down by setting Bit 6 in the Interrupt Control Register to “1”, the level on this pin will terminate power down if it rises about 1.0V above the level at the V_{BATT} input pin after previously falling below V_{BATT} +1.0V. When power-down is terminated, the PSE pin will return high and the Clock Output will be enabled. The CPU_R output pin will also return high. The logic level present at this pin at the end of POR determines the CDP68HC68T1’s operating mode.

V_{BATT}

The oscillator power source. The positive terminal of the battery should be connected to this pin. When the level on the V_{sys} pin falls below V_{BATT} +1.0V, the V_{BATT} pin will be internally connected to the V_{DD} pin. When the voltage on V_{sys} rises a threshold above (1.0V) the voltage on V_{BATT}, the connection from V_{BATT} to the V_{DD} pin is opened. When the “LINE” input is used as the frequency source, V_{BATT} may be tied to V_{DD} or V_{SS}. The “XTAL IN” pin must be at V_{SS} if V_{BATT} is at V_{SS}. If V_{BATT} is connected to V_{DD}, the “XTAL IN” pin can be tied to V_{SS} or V_{DD}.

XTAL IN, XTAL OUT

These pins are connected to a 32,768Hz, 1.048576MHz, 2.097152MHz or 4.194304MHz crystal. If an external clock is used, it should be connected to “XTAL IN” with ‘XTAL OUT’ left open.

V_{DD}

The positive power-supply pin.

Clock Control Register

Start-Stop

A high written into this bit will enable the counter stages of the clock circuitry. A low will hold all bits reset in the divider chain from 32Hz to 1Hz. A clock out selected by Bit 0, Bit 1 and Bit 2 will not be affected by the stop function except the 1Hz and 2Hz outputs.

Line-XTAL

When this bit is set high, clock operation will use the 50-cycle or 60-cycle input present at the LINE input pin. When the bit is low, the crystal input will generate the 1Hz time update.

XTAL Select

One of 4 possible crystals is selected by value in these two bits:

- 0 = 4.194304MHz 2 = 1.048576MHz
- 1 = 2.097152MHz 3 = 32,768Hz

50Hz to 60Hz

50Hz is selected as the line input frequency when this bit is set high. A low will select 60Hz. The power-sense bit in the Interrupt Control Register must be set low for line frequency operation.

Clock Out

The three bits specify one of the 7 frequencies to be used as the squarewave clock output:

- 0 = XTAL 4 = Disable (low output)
- 1 = XTAL/2 5 = 1Hz
- 2 = XTAL/4 6 = 2Hz
- 3 = XTAL/8 7 = 50Hz or 60Hz
- XTAL Operation = 64Hz

All bits are reset by a power-on reset. Therefore, the XTAL is selected as the clock output at this time.

Interrupt Control Register

Watchdog

When this bit is set high, the watchdog operation will be enabled. This function requires the CPU to toggle the CE pin periodically without a serial-transfer requirement. In the event this does not occur, a CPU reset will be issued. Status Register must be read before re-enabling watchdog.

Power-Down

A high in this location will initiate a power down. A CPU reset will occur, the CLK OUT and PSE output pins will be set low and the serial interface will be disabled.

Power Sense

This bit is used to enable the line input pin to sense a power failure. It is set high for this function. When power sense is selected, the input to the 50Hz to 60Hz prescaler is disconnected. Therefore, crystal operation is required when power sense is enabled. An interrupt is generated when a power failure is sensed and the power sense and Interrupt True bit in the Status Register are set. When power sense is activated, a “0” must be written to this location followed by a “1” to re-enable power sense.

Alarm

The output of the alarm comparator is enabled when this bit is set high. When a comparison occurs between the seconds, minutes and hours time and alarm counters, the interrupt output is activated. When loading the time counters, this bit should be set low to avoid a false interrupt. This is not required when loading the alarm counters. See "Functional Description", INT for explanation of alarm delay on page 10.

Periodic Select

The value in these 4 bits will select the frequency of the periodic output. (See Table 3).

CLOCK CONTROL REGISTER (Write/Read) - Address 31H

D7	D6	D5	D4	D3	D2	D1	D0
START	LINE	XTAL	XTAL	50Hz	CLK OUT	CLK OUT	CLK OUT
		SEL	SEL				
STOP	XTAL	1	0	60Hz	2	1	0

INTERRUPT CONTROL REGISTER (Write/Read) - Address 32H

D7	D6	D5	D4	D3	D2	D1	D0
WATCHDOG	POWER DOWN	POWER SENSE	ALARM	PERIODIC SELECT			

NOTE: All bits are reset by power-on reset.





TABLE 3. PERIODIC INTERRUPT OUTPUT

D0 - D3 VALUE	PERIODIC INTERRUPT OUTPUT FREQUENCY	FREQUENCY TIME BASE	
		XTAL	LINE
0	Disable		
1	2048Hz	X	
2	1024Hz	X	
3	512Hz	X	
4	256Hz	X	
5	128Hz	X	
6	64Hz	X	
	50Hz or 60Hz		X
7	32Hz	X	
8	16Hz	X	
9	8Hz	X	
10	4Hz	X	
11	2Hz	X	X
12	1Hz	X	X
13	Minute	X	X
14	Hour	X	X
15	Day	X	X

STATUS REGISTER (Read Only) - Address 30H

D7	D6	D5	D4	D3	D2	D1	D0
0	WATCHDOG	TEST MODE	FIRST TIME UP	INTERRUPT TRUE	POWER SENSE INTERRUPT	ALARM INTERRUPT	CLOCK INTERRUPT

TRUTH TABLE

MODE	SIGNAL			
	CE	SCK (Note 9)	MOSI	MISO
DISABLE RESET	L	INPUT DISABLED	INPUT DISABLED	HIGH Z
WRITE	H	CPOL = 1  CPOL = 0 	DATA BIT LATCH	HIGH Z
READ	H	CPOL = 1  CPOL = 0 	X	NEXT DATA BIT SHIFTED OUT (Note 10)

NOTES:

- 9. When interfacing to CDP68HC05 microcontrollers, serial clock phase bit, CPHA, must be set = 1 in the microcomputer's Control Register.
- 10. MISO remains at a high Z until 8-bits of data are ready to be shifted out during a READ. It remains at a high Z during the entire WRITE cycle.

Watchdog

If this bit is set high, the watchdog circuit has detected a CPU failure.

Test Mode

When this bit is set high, the device is in the TEST MODE.

First-time Up

Power-on reset sets this bit high. This signifies that data in the RAM and Clock is not valid and should be initialized.

Interrupt True

A high in this bit signifies that one of the three interrupts (Power Sense, Alarm, and Clock) is valid.

Power-sense Interrupt

This bit set high signifies that the power-sense circuit has generated an interrupt.

Alarm Interrupt

When the seconds, minutes and hours time and alarm counter are equal, this bit will be set high. Status Register must be read before loading Interrupt Control Register for valid alarm indication after alarm activates.

Clock Interrupt

A periodic interrupt will set this bit high.

All bits are reset by a power-on reset except the "FIRST-TIME UP" which is set. All bits except the power-sense bit are reset after a read of this register.

Pin Signal Description

SCK (Serial Clock Input) (Note 11)

This input causes serial data to be latched from the MOSI input and shifted out on the MISO output.

MOSI (Master Out/Slave In) (Note 11)

Data bytes are shifted in at this pin, most significant bit (MSB) first.

MISO (Master In/Slave Out)

Data bytes are shifted out at this pin, most significant bit (MSB) first.

CE (Chip Enable) (Note 12)

A positive chip-enable input. A low level at this input holds the serial interface logic in a reset state, and disables the output driver at the MISO pin.

NOTES:

- 11. These inputs will retain their previous state if the line driving them goes into a High-Z state.
- 12. The CE input has an internal pull-down device, if the input is in a low state before going to High Z, the input can be left in a High Z.

Functional Description

The Serial Peripheral Interface (SPI) utilized by the CDP68HC68T1 is a serial synchronous bus for address and data transfers. The clock, which is generated by the microcomputer is active only during address and data transfers. In systems using the CDP68HC05C4 or CDP68HC05D2, the inactive clock polarity is determined by the CPOL bit in the microcomputer's Control Register. A unique feature of the CDP68HC68T1 is that it automatically determines the level of the inactive clock by sampling SCK when CE becomes active (see Figure 8). Input data (MOSI) is latched internally on the internal strobe edge and output data (MISO) is shifted out on the shift edge, as defined by Figure 8. There is one clock for each data bit transferred (address, as well as data bits are transferred in groups of 8).

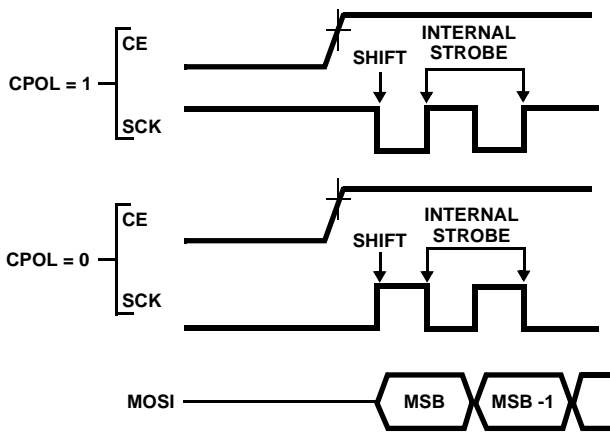

NOTE: "CPOL" is a bit that is set in the microcomputer's Control Register.

FIGURE 8. SERIAL RAM CLOCK (SCK) AS A FUNCTION OF MCU CLOCK POLARITY (CPOL)

Address and Data Format

There are three types of serial transfer:

1. Address Control - Figure 9.
2. READ or WRITE Data - Figure 10.
3. Watchdog Reset (actually a non-transfer) Figure 11.

The Address/Control and Data bytes are shifted MSB first, Into the serial data input (MOSI) and out of the serial data output (MISO).

Any transfer of data requires an Address/Control byte to specify a Write or Read operation and to select a Clock or RAM location, followed by one or more bytes of data.

Data is transferred out of MISO for a Read and into MOSI for a Write operation.

Address/Control Byte - (see Figure 9)

It is always the first byte received after CE goes true. To transmit a new address, CE must first go false and then true again. Bit 5 is used to select between Clock and RAM locations. Bit 5 is used to select between Clock and RAM locations.

BIT →	7	6	5	4	3	2	1	0
↓	W/R	0	CLK RAM	A4	A3	A2	A1	A0
04		A0 through A4		Selects 5-bit HEX Address of RAM or specifies Clock Register. Most Significant Address Bit. If equal to "1", A0 through A4 selects a Clock Register. If equal to "0", A0 through A4 selects one of 32 RAM locations. Must be set to "0" when not in Test Mode 7W/R W/R = "1" initiates one or more WRITE cycles.W/R = "0", initiates one or more READ cycles.				
5		CLK RAM						
6		0						
7		W/R						

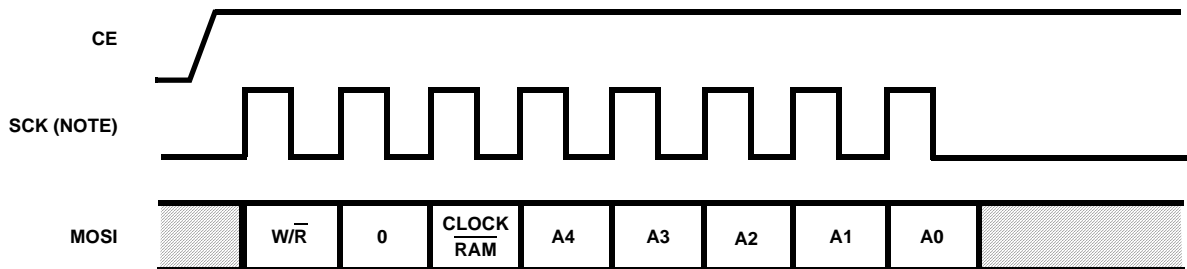

NOTE: SCK can be either polarity.

FIGURE 9. ADDRESS/CONTROL BYTE-TRANSFER WAVEFORMS

Read/Write Data (See Figure 10)

Read/Write data follows the Address/Control byte.

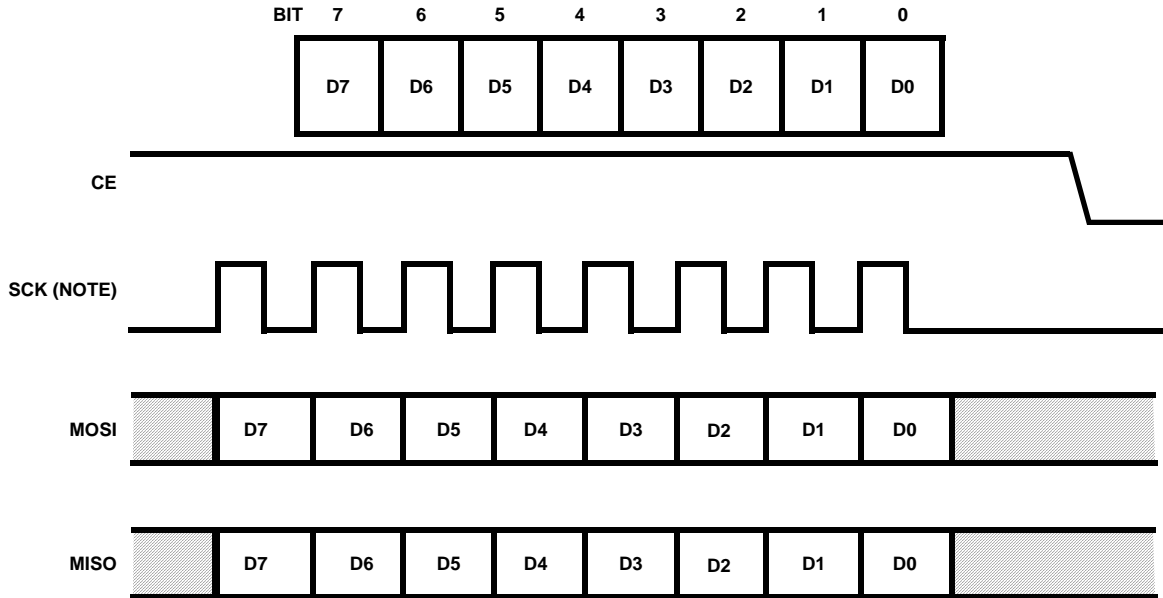

NOTE: SCK can be either polarity.

FIGURE 10. READ/WRITE DATA TRANSFER WAVEFORMS

Watchdog Reset (See Figure 11)

When watchdog operation is selected, CE must be toggled periodically or a CPU reset will be outputted.

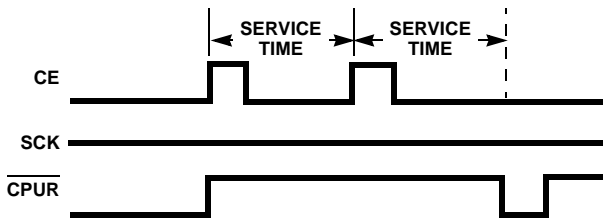

FIGURE 11. WATCHDOG OPERATION WAVEFORMS

Address and Data

Data transfers can occur one byte at a time (Figure 12) or in a multibyte burst mode (Figure 13). After the Real-Time Clock enabled, an Address/Control word is sent to set the CLOCK or RAM and select the type of operation (i.e., Read or Write). For a single-byte Read or Write, one byte is transferred to or from the Clock Register or RAM location specified in the Address/Control byte and the Real-Time Clock is then disabled. Write cycle causes the latched Clock Register or RAM address to automatically increment. Incrementing continues after each transfer until the device is disabled. After incrementing to 1FH the address will “wrap” to 00H and continue. Therefore, when the RAM is selected the address will “wrap” to 00H and when the clock is selected the address will “wrap” 20H.

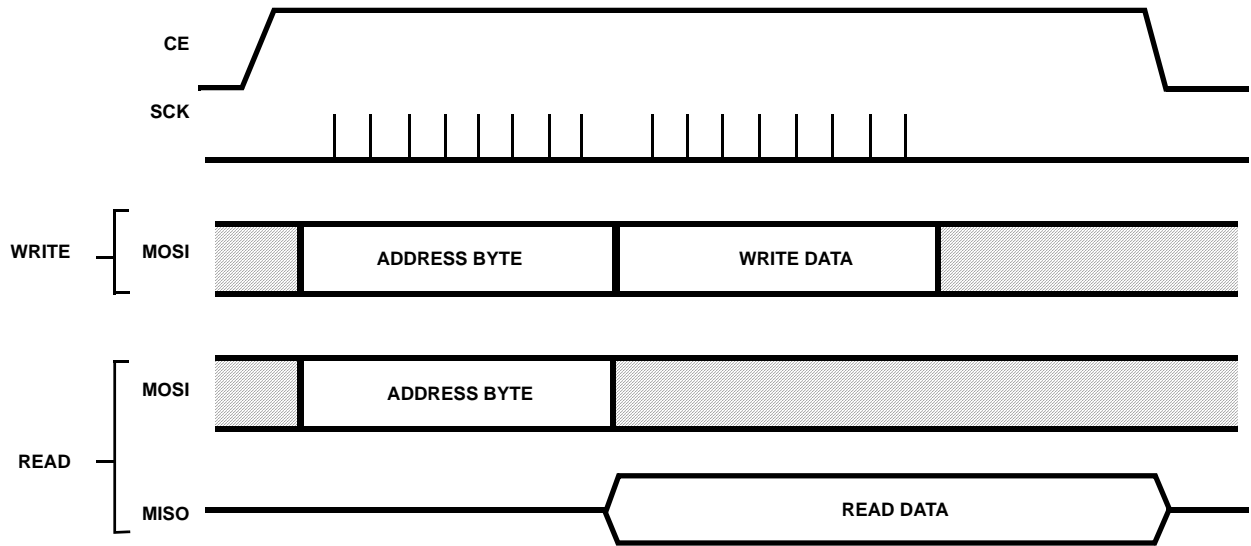

FIGURE 12. SINGLE-BYTE TRANSFER WAVEFORMS

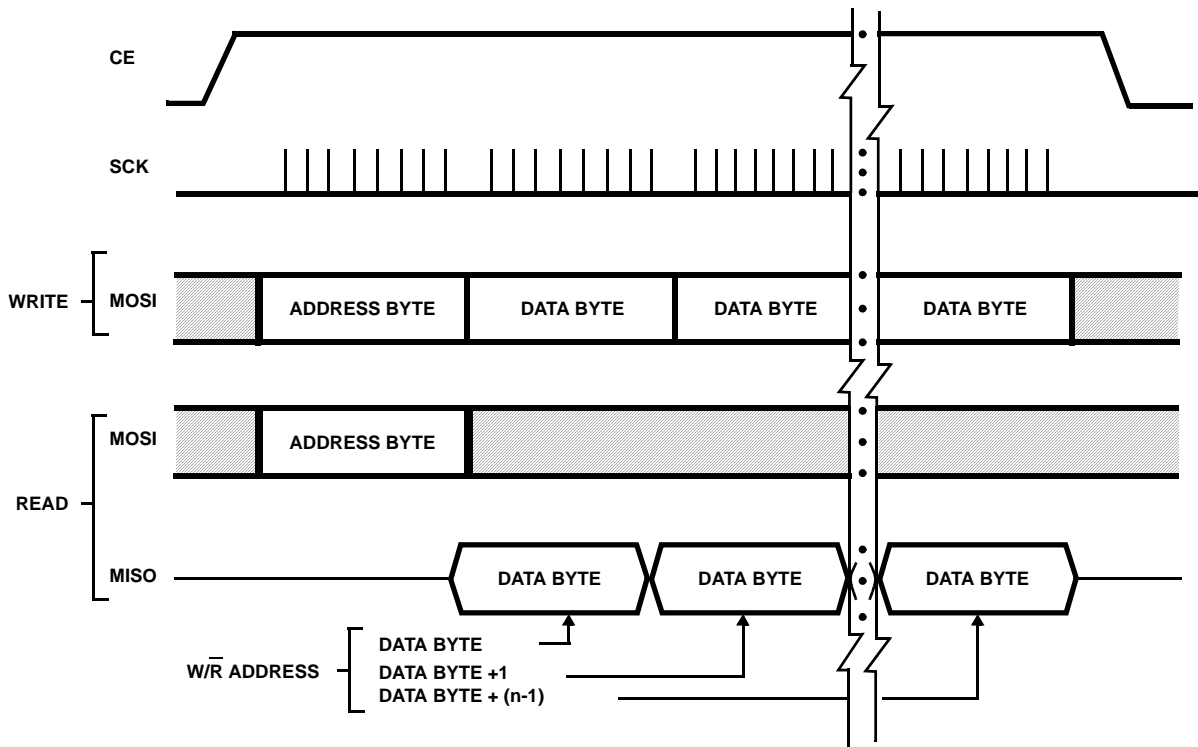

FIGURE 13. MULTIPLE-BYTE TRANSFER WAVEFORMS

Timing Diagrams

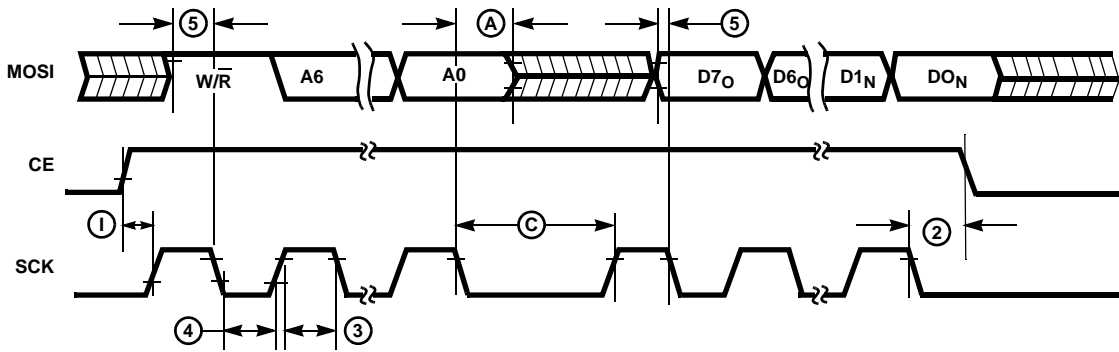

FIGURE 14. WRITE-CYCLE TIMING WAVEFORMS

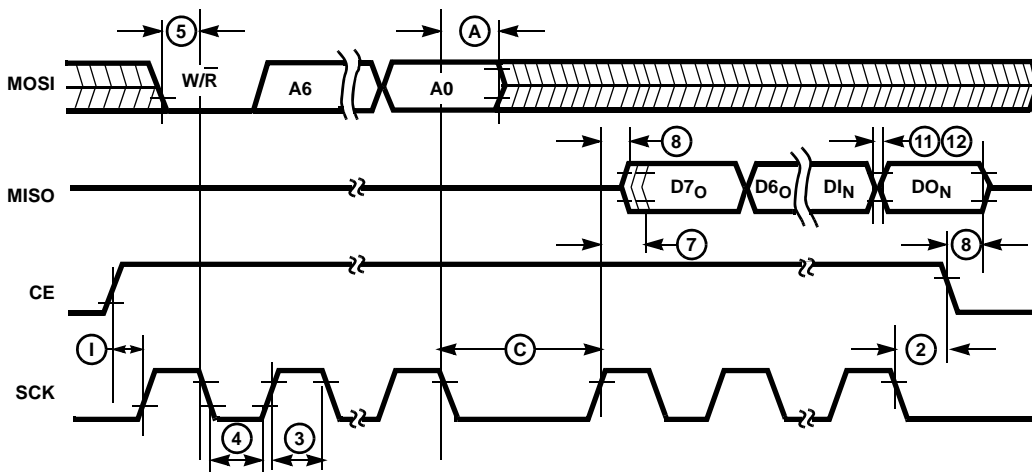
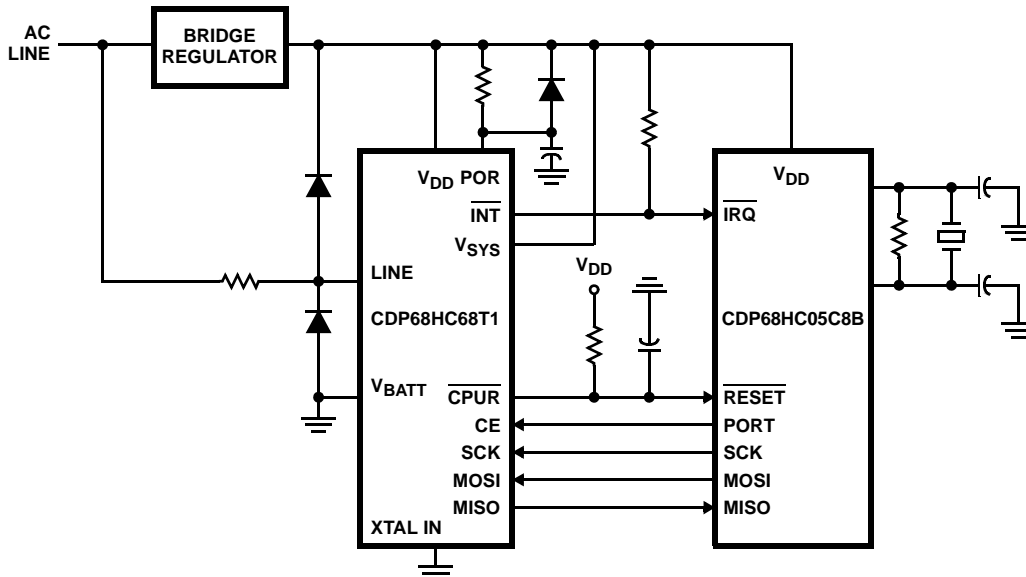

FIGURE 15. READ-CYCLE TIMING WAVEFORMS

System Diagrams



NOTE: Example of a system in which power is always on. Clock circuit driven by line input frequency.

FIGURE 16. POWER-ON ALWAYS SYSTEM DIAGRAM

System Diagrams (Continued)

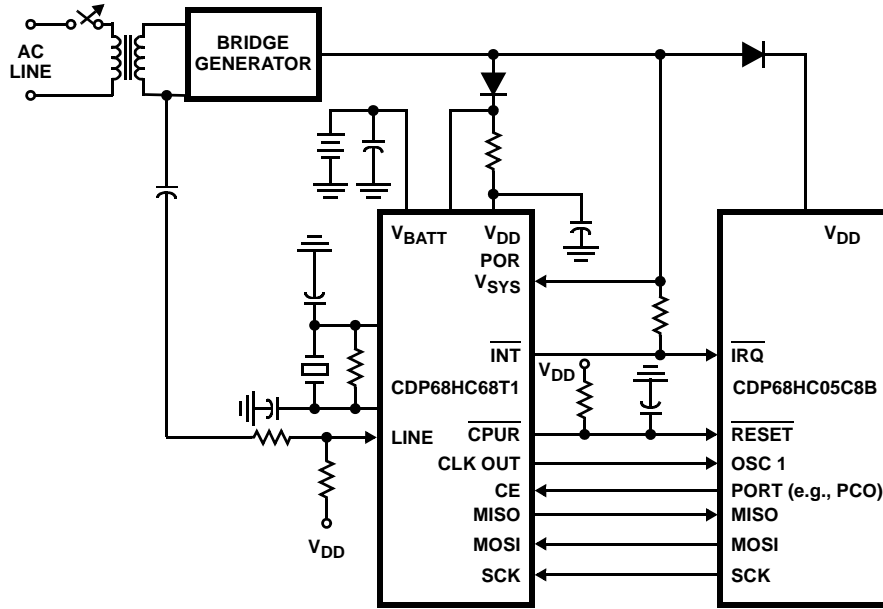

NOTE: Example of a system in which the power is controlled by an external source. The LINE input pin can sense when the switch opens by use of the POWER-SENSE INTERRUPT. The CDP68HC68T1 crystal drives the clock input to the CPU using the CLK OUT pin. On power down when $V_{SYS} < V_{BATT} + 1.0V$, V_{BATT} will power the CDP68HC68T1. A threshold detect activates a P-Channel switch, connecting V_{BATT} to V_{DD} . V_{BATT} always supplies power to the oscillator, keeping voltage frequency variation to a minimum.

FIGURE 17. EXTERNALLY CONTROLLED POWER SYSTEM DIAGRAM

A Procedure for Power-Down Operation might consist of the following:

1. Set power sense operation by writing Bit 5 high in the Interrupt Control Register.
2. When an interrupt occurs, the CPU reads the Status Register to determine the interrupt source.
3. Sensing a power failure, the CPU does the necessary housekeeping to prepare for shutdown.
4. The CPU reads the Status Register again after several milliseconds to determine validity of power failure.
5. The CPU sets power-down Bit 6 and disables all interrupts in the Interrupt Control Register when power down is verified. This causes the CPU reset and clock out to be held low and disconnects the serial interface.
6. When power returns and V_{SYS} rises above V_{BATT} , power-down is terminated. The CPU reset is released and serial communication is established.

System Diagrams (Continued)

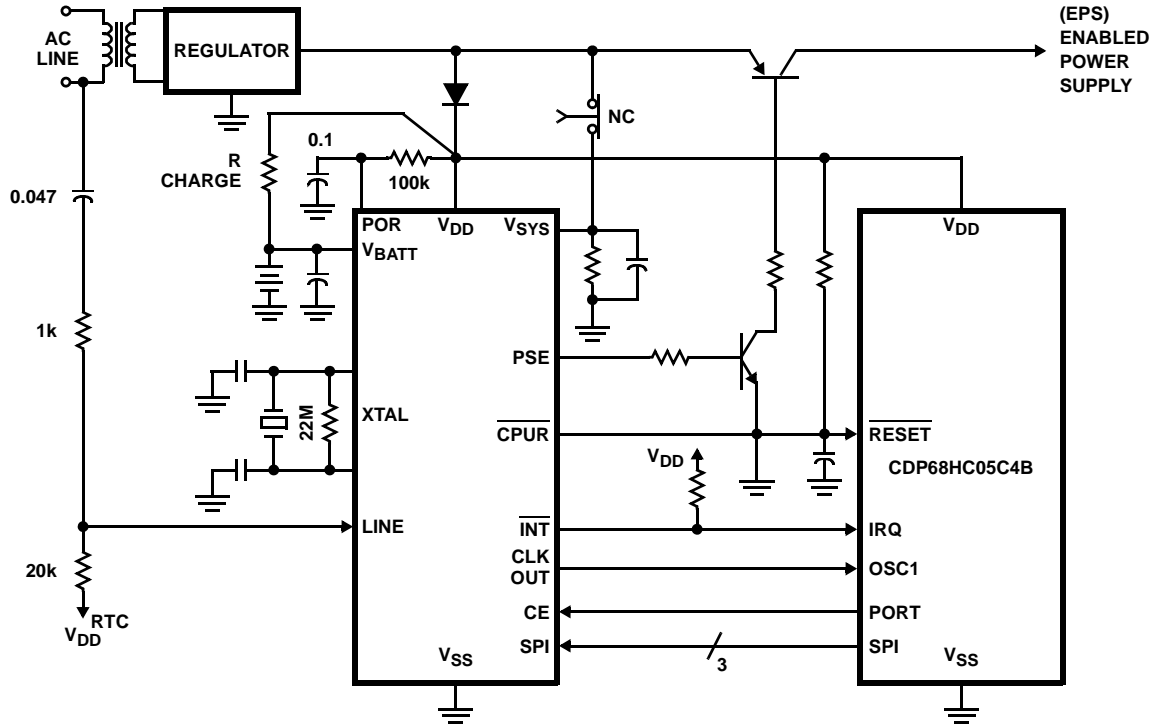
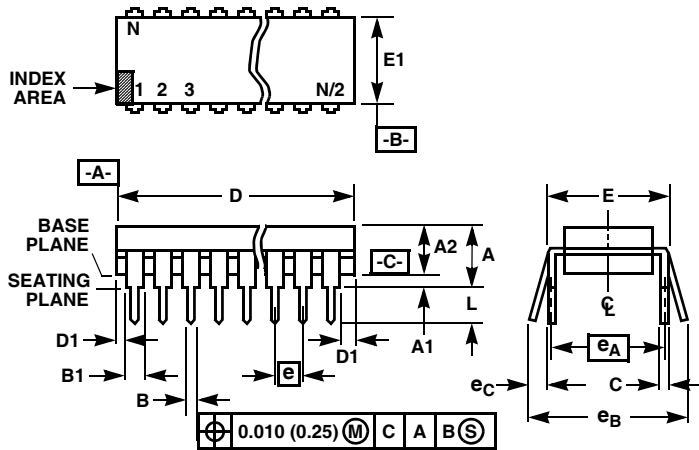

FIGURE 18. EXAMPLE OF A SYSTEM WITH A BATTERY BACKUP

Dual-In-Line Plastic Packages (PDIP)



NOTES:

1. Controlling Dimensions: INCH. In case of conflict between English and Metric dimensions, the inch dimensions control.
2. Dimensioning and tolerancing per ANSI Y14.5M-1982.
3. Symbols are defined in the "MO Series Symbol List" in Section 2.2 of Publication No. 95.
4. Dimensions A, A1 and L are measured with the package seated in JEDEC seating plane gauge GS-3.
5. D, D1, and E1 dimensions do not include mold flash or protrusions. Mold flash or protrusions shall not exceed 0.010 inch (0.25mm).
6. E and e_A are measured with the leads constrained to be perpendicular to datum -C-.
7. e_B and e_C are measured at the lead tips with the leads unconstrained. e_C must be zero or greater.
8. B1 maximum dimensions do not include dambar protrusions. Dambar protrusions shall not exceed 0.010 inch (0.25mm).
9. N is the maximum number of terminal positions.
10. Corner leads (1, N, N/2 and N/2 + 1) for E8.3, E16.3, E18.3, E28.3, E42.6 will have a B1 dimension of 0.030 - 0.045 inch (0.76 - 1.14mm).

E16.3 (JEDEC MS-001-BB ISSUE D)
16 LEAD DUAL-IN-LINE PLASTIC PACKAGE

SYMBOL	INCHES		MILLIMETERS		NOTES
	MIN	MAX	MIN	MAX	
A	-	0.210	-	5.33	4
A1	0.015	-	0.39	-	4
A2	0.115	0.195	2.93	4.95	-
B	0.014	0.022	0.356	0.558	-
B1	0.045	0.070	1.15	1.77	8, 10
C	0.008	0.014	0.204	0.355	-
D	0.735	0.775	18.66	19.68	5
D1	0.005	-	0.13	-	5
E	0.300	0.325	7.62	8.25	6
E1	0.240	0.280	6.10	7.11	5
e	0.100 BSC		2.54 BSC		-
e_A	0.300 BSC		7.62 BSC		6
e_B	-	0.430	-	10.92	7
L	0.115	0.150	2.93	3.81	4
N	16		16		9

Rev. 0 12/93

Small Outline Plastic Packages (SOIC)

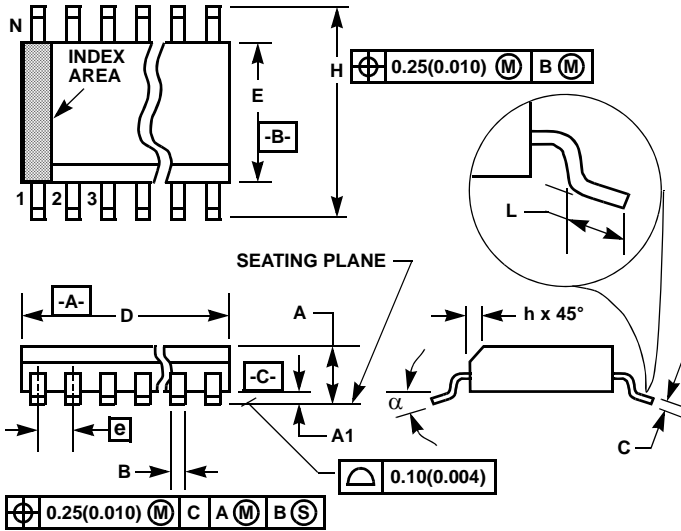

M16.3 (JEDEC MS-013-AA ISSUE C)
16 LEAD WIDE BODY SMALL OUTLINE PLASTIC PACKAGE

SYMBOL	INCHES		MILLIMETERS		NOTES
	MIN	MAX	MIN	MAX	
A	0.0926	0.1043	2.35	2.65	-
A1	0.0040	0.0118	0.10	0.30	-
B	0.013	0.0200	0.33	0.51	9
C	0.0091	0.0125	0.23	0.32	-
D	0.3977	0.4133	10.10	10.50	3
E	0.2914	0.2992	7.40	7.60	4
e	0.050 BSC		1.27 BSC		-
H	0.394	0.419	10.00	10.65	-
h	0.010	0.029	0.25	0.75	5
L	0.016	0.050	0.40	1.27	6
N	16		16		7
alpha	0°	8°	0°	8°	-

NOTES:

1. Symbols are defined in the "MO Series Symbol List" in Section 2.2 of Publication Number 95.
2. Dimensioning and tolerancing per ANSI Y14.5M-1982.
3. Dimension "D" does not include mold flash, protrusions or gate burrs. Mold flash, protrusion and gate burrs shall not exceed 0.15mm (0.006 inch) per side.
4. Dimension "E" does not include interlead flash or protrusions. Interlead flash and protrusions shall not exceed 0.25mm (0.010 inch) per side.
5. The chamfer on the body is optional. If it is not present, a visual index feature must be located within the crosshatched area.
6. "L" is the length of terminal for soldering to a substrate.
7. "N" is the number of terminal positions.
8. Terminal numbers are shown for reference only.
9. The lead width "B", as measured 0.36mm (0.014 inch) or greater above the seating plane, shall not exceed a maximum value of 0.61mm (0.024 inch)
10. Controlling dimension: MILLIMETER. Converted inch dimensions are not necessarily exact.

Rev. 1 6/05

Small Outline Plastic Packages (SOIC)

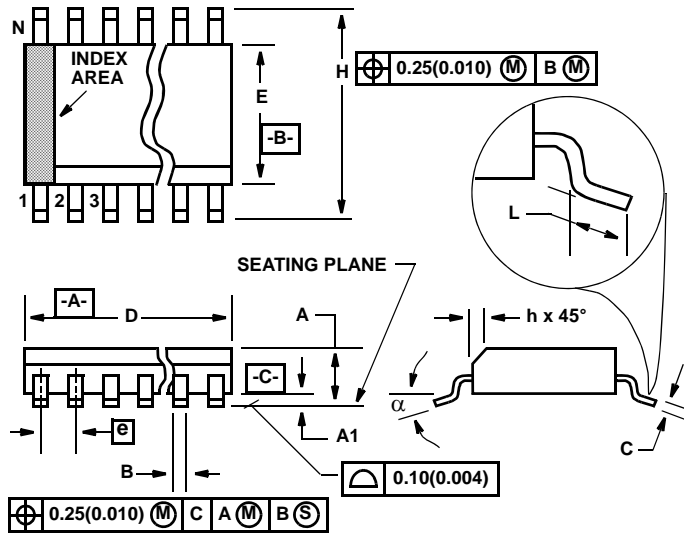

M20.3 (JEDEC MS-013-AC ISSUE C)
20 LEAD WIDE BODY SMALL OUTLINE PLASTIC PACKAGE

SYMBOL	INCHES		MILLIMETERS		NOTES
	MIN	MAX	MIN	MAX	
A	0.0926	0.1043	2.35	2.65	-
A1	0.0040	0.0118	0.10	0.30	-
B	0.014	0.019	0.35	0.49	9
C	0.0091	0.0125	0.23	0.32	-
D	0.4961	0.5118	12.60	13.00	3
E	0.2914	0.2992	7.40	7.60	4
e	0.050 BSC		1.27 BSC		-
H	0.394	0.419	10.00	10.65	-
h	0.010	0.029	0.25	0.75	5
L	0.016	0.050	0.40	1.27	6
N	20		20		7
α	0°	8°	0°	8°	-

NOTES:

1. Symbols are defined in the "MO Series Symbol List" in Section 2.2 of Publication Number 95.
2. Dimensioning and tolerancing per ANSI Y14.5M-1982.
3. Dimension "D" does not include mold flash, protrusions or gate burrs. Mold flash, protrusion and gate burrs shall not exceed 0.15mm (0.006 inch) per side.
4. Dimension "E" does not include interlead flash or protrusions. Interlead flash and protrusions shall not exceed 0.25mm (0.010 inch) per side.
5. The chamfer on the body is optional. If it is not present, a visual index feature must be located within the crosshatched area.
6. "L" is the length of terminal for soldering to a substrate.
7. "N" is the number of terminal positions.
8. Terminal numbers are shown for reference only.
9. The lead width "B", as measured 0.36mm (0.014 inch) or greater above the seating plane, shall not exceed a maximum value of 0.61mm (0.024 inch)
10. Controlling dimension: MILLIMETER. Converted inch dimensions are not necessarily exact.

Rev. 2 6/05

All Intersil U.S. products are manufactured, assembled and tested utilizing ISO9000 quality systems. Intersil Corporation's quality certifications can be viewed at www.intersil.com/design/quality

Intersil products are sold by description only. Intersil Corporation reserves the right to make changes in circuit design, software and/or specifications at any time without notice. Accordingly, the reader is cautioned to verify that data sheets are current before placing orders. Information furnished by Intersil is believed to be accurate and reliable. However, no responsibility is assumed by Intersil or its subsidiaries for its use; nor for any infringements of patents or other rights of third parties which may result from its use. No license is granted by implication or otherwise under any patent or patent rights of Intersil or its subsidiaries.

For information regarding Intersil Corporation and its products, see www.intersil.com