

# CDCV857B, CDCV857BI

## 2.5-V PHASE-LOCK LOOP CLOCK DRIVER

SCAS689A – FEBRUARY 2003 – REVISED NOVEMBER 2010

- Phase-Lock Loop Clock Driver for Double Data-Rate Synchronous DRAM Applications
- Spread Spectrum Clock Compatible
- Operating Frequency: 60 MHz to 200 MHz
- Low Jitter (cycle-cycle):  $\pm 50$  ps
- Low Static Phase Offset:  $\pm 50$  ps
- Low Jitter (Period):  $\pm 35$  ps
- Distributes One Differential Clock Input to 10 Differential Outputs
- Enters Low-Power Mode When No CLK Input Signal Is Applied or PWRDWN Is Low
- Operates From Dual 2.5-V Supplies
- Available in a 48-Pin TSSOP Package or 56-Ball MicroStar Junior™ BGA Package
- Consumes  $< 100\text{-}\mu\text{A}$  Quiescent Current
- External Feedback Pins (FBIN, FBIN) Are Used to Synchronize the Outputs to the Input Clocks
- Meets/Exceeds the Latest DDR JEDEC Spec JESD82–1

### Description

The CDCV857B is a high-performance, low-skew, low-jitter zero delay buffer that distributes a differential clock input pair (CLK,  $\overline{\text{CLK}}$ ) to 10 differential pairs of clock outputs (Y[0:9],  $\overline{\text{Y}}[0:9]$ ) and one differential pair of feedback clock outputs (FBOUT,  $\overline{\text{FBOUT}}$ ). The clock outputs are controlled by the clock inputs (CLK,  $\overline{\text{CLK}}$ ), the feedback clocks (FBIN,  $\overline{\text{FBIN}}$ ), and the analog power input (AV<sub>DD</sub>). When  $\overline{\text{PWRDWN}}$  is high, the outputs switch in phase and frequency with CLK. When  $\overline{\text{PWRDWN}}$  is low, all outputs are disabled to a high-impedance state (3-state) and the PLL is shut down (low-power mode). The device also enters this low-power mode when the input frequency falls below a suggested detection frequency that is below 20 MHz (typical 10 MHz). An input frequency detection circuit detects the low frequency condition and, after applying a  $>20\text{-MHz}$  input signal, this detection circuit turns the PLL on and enables the outputs.

When AV<sub>DD</sub> is strapped low, the PLL is turned off and bypassed for test purposes. The CDCV857B is also able to track spread spectrum clocking for reduced EMI.

Since the CDCV857B is based on PLL circuitry, it requires a stabilization time to achieve phase-lock of the PLL. This stabilization time is required following power up. The CDCV857B is characterized for both commercial and industrial temperature ranges.

#### AVAILABLE OPTIONS

T <sub>A</sub>	TSSOP (DGG)	MicroStar Junior™ BGA (GQL)
0°C to 85°C	CDCV857BDGG	CDCV857BGQL
–40°C to 85°C	CDCV857BIDGG	—

#### FUNCTION TABLE (Select Functions)

INPUTS				OUTPUTS				PLL
AV <sub>DD</sub>	PWRDWN	CLK	$\overline{\text{CLK}}$	Y[0:9]	$\overline{\text{Y}}[0:9]$	FBOUT	$\overline{\text{FBOUT}}$	
GND	H	L	H	L	H	L	H	Bypassed/Off
GND	H	H	L	H	L	H	L	Bypassed/Off
X	L	L	H	Z	Z	Z	Z	Off
X	L	H	L	Z	Z	Z	Z	Off
2.5 V (nom)	H	L	H	L	H	L	H	On
2.5 V (nom)	H	H	L	H	L	H	L	On
2.5 V (nom)	X	$<20$ MHz	$<20$ MHz	Z	Z	Z	Z	Off



Please be aware that an important notice concerning availability, standard warranty, and use in critical applications of Texas Instruments semiconductor products and disclaimers thereto appears at the end of this data sheet.

MicroStar Junior is a trademark of Texas Instruments Incorporated.

PRODUCTION DATA information is current as of publication date. Products conform to specifications per the terms of Texas Instruments standard warranty. Production processing does not necessarily include testing of all parameters.



POST OFFICE BOX 655303 • DALLAS, TEXAS 75265

Copyright © 2003, Texas Instruments Incorporated

# CDCV857B, CDCV857BI

## 2.5-V PHASE-LOCK LOOP CLOCK DRIVER

SCAS689A – FEBRUARY 2003 – REVISED NOVEMBER 2010

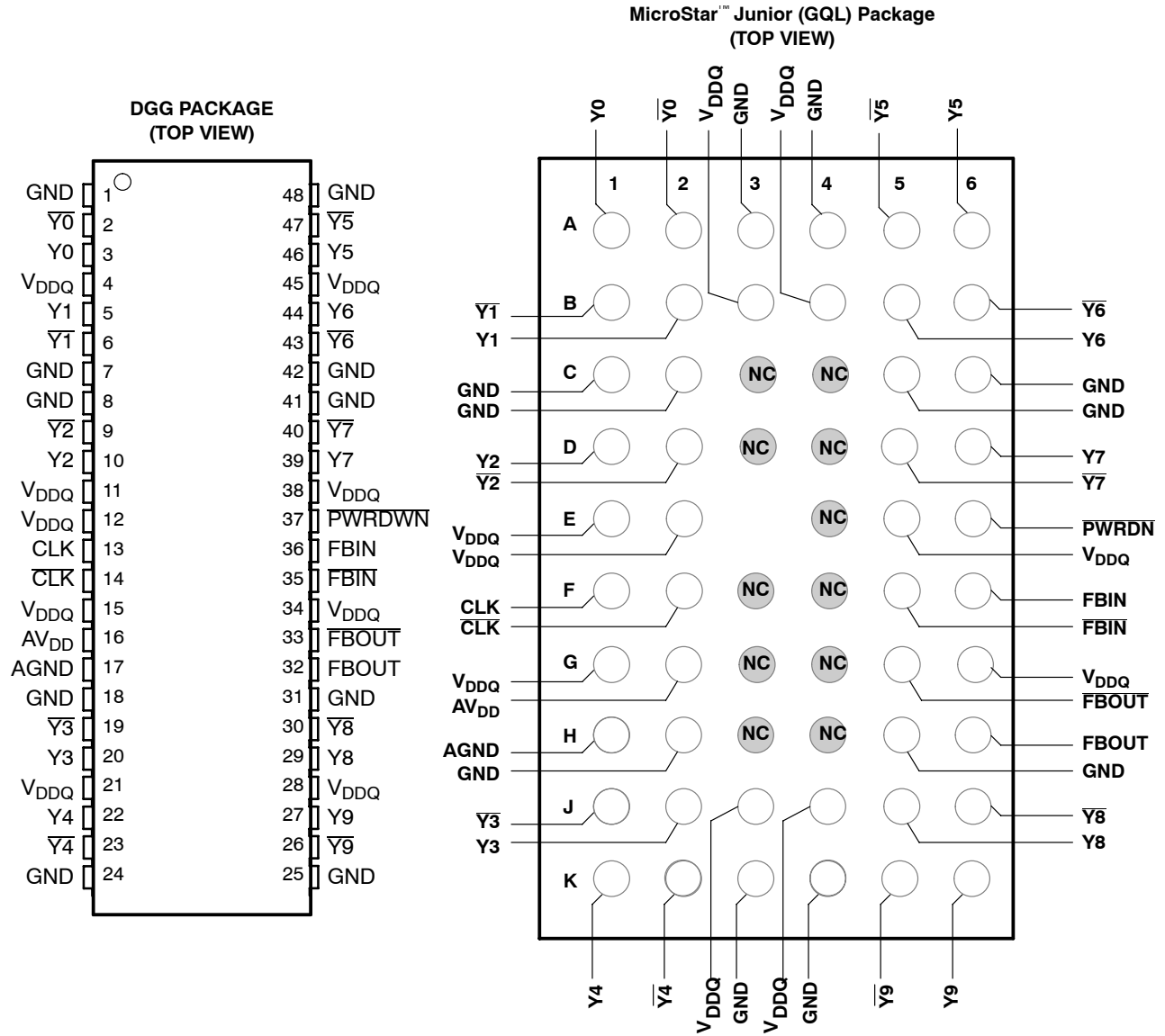

# CDCV857B, CDCV857BI 2.5-V PHASE-LOCK LOOP CLOCK DRIVER

SCAS689A – FEBRUARY 2003 – REVISED NOVEMBER 2010

## functional block diagram

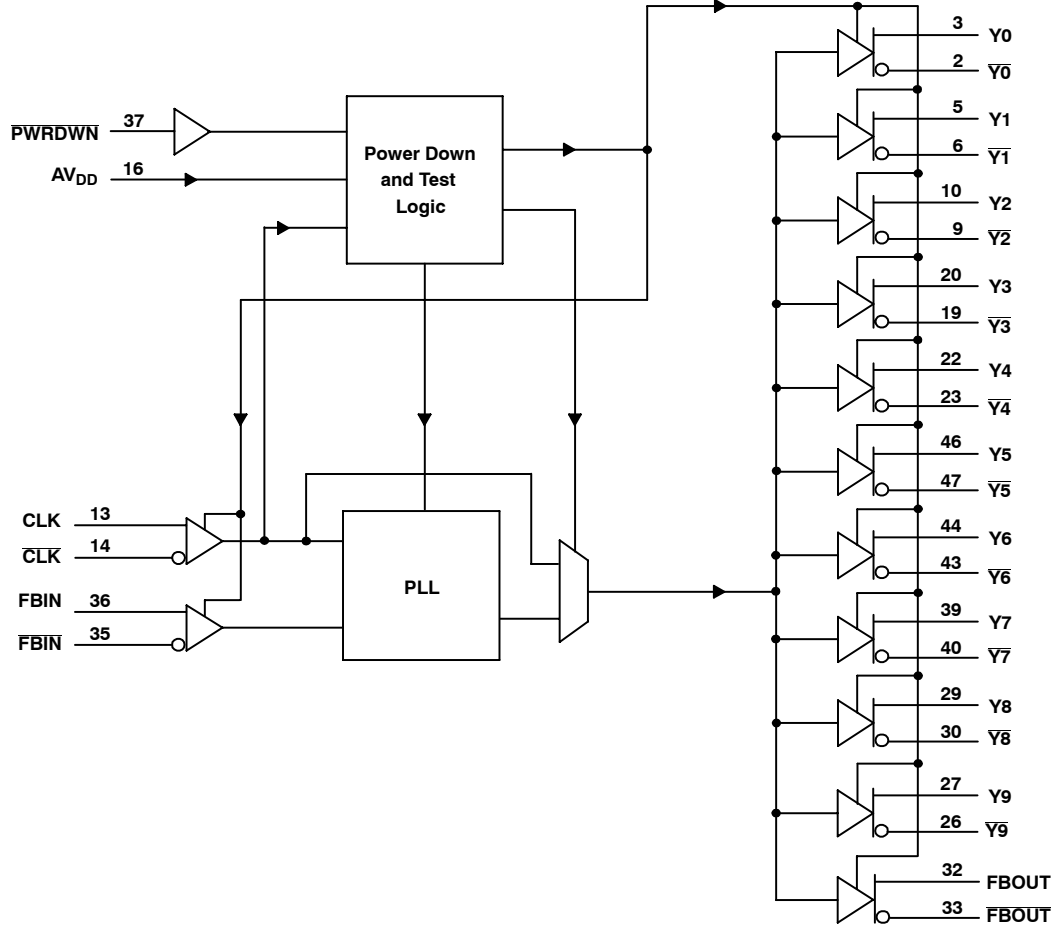

# CDCV857B, CDCV857BI

## 2.5-V PHASE-LOCK LOOP CLOCK DRIVER

SCAS689A – FEBRUARY 2003 – REVISED NOVEMBER 2010

### Terminal Functions

TERMINAL				DESCRIPTION
NAME	DGG	GQL		
AGND	17	H1		Ground for 2.5-V analog supply
AV <sub>DD</sub>	16	G2		2.5-V Analog supply
CLK, $\overline{\text{CLK}}$	13, 14	F1, F2	I	Differential clock input
$\overline{\text{FBIN}}$ , FBIN	35, 36	F5, F6	I	Feedback differential clock input
$\overline{\text{FBOU}}$ , FBOU	32, 33	H6, G5	O	Feedback differential clock output
GND	1, 7, 8, 18, 24, 25, 31, 41, 42, 48	A3, A4, C1, C2, C5, C6, H2, H5, K3, K4		Ground
$\overline{\text{PWRDWN}}$	37	E6	I	Output enable for Y and $\overline{\text{Y}}$
V <sub>DDQ</sub>	4, 11, 12, 15, 21, 28, 34, 38, 45	B3, B4, E1, E2, E5, G1, G6, J3, J4		2.5-V Supply
Y[0:9]	3, 5, 10, 20, 22, 27, 29, 39, 44, 46	A1, B2, D1, J2, K1, A6, B5, D6, J5, K6	O	Buffered output copies of input clock, CLK
$\overline{\text{Y}}$ [0:9]	2, 6, 9, 19, 23, 26, 30, 40, 43, 47	A2, B1, D2, J1, K2, A5, B6, D5, J6, K5	O	Buffered output copies of input clock, $\overline{\text{CLK}}$

### absolute maximum ratings over operating free-air temperature (unless otherwise noted)<sup>†</sup>

Supply voltage range, V <sub>DDQ</sub> , AV <sub>DD</sub>	0.5 V to 3.6 V
Input voltage range, V <sub>I</sub> (see Notes 1 and 2)	-0.5 V to V <sub>DDQ</sub> + 0.5 V
Output voltage range, V <sub>O</sub> (see Notes 1 and 2)	-0.5 V to V <sub>DDQ</sub> + 0.5 V
Input clamp current, I <sub>IK</sub> (V <sub>I</sub> < 0 or V <sub>I</sub> > V <sub>DDQ</sub> )	±50 mA
Output clamp current, I <sub>OK</sub> (V <sub>O</sub> < 0 or V <sub>O</sub> > V <sub>DDQ</sub> )	±50 mA
Continuous output current, I <sub>O</sub> (V <sub>O</sub> = 0 to V <sub>DDQ</sub> )	±50 mA
Continuous current to GND or V <sub>DDQ</sub>	±100 mA
Package thermal impedance, $\theta_{JA}$ (see Note 3): GQL package	137.6°C/W
Storage temperature range T <sub>stg</sub>	-65°C to 150°C

<sup>†</sup> Stresses beyond those listed under “absolute maximum ratings” may cause permanent damage to the device. These are stress ratings only, and functional operation of the device at these or any other conditions beyond those indicated under “recommended operating conditions” is not implied. Exposure to absolute-maximum-rated conditions for extended periods may affect device reliability.

NOTES: 1. The input and output negative voltage ratings may be exceeded if the input and output clamp current ratings are observed.

2. This value is limited to 3.6 V maximum.

3. The package thermal impedance is calculated in accordance with JESD 51.



# CDCV857B, CDCV857BI

## 2.5-V PHASE-LOCK LOOP CLOCK DRIVER

SCAS689A – FEBRUARY 2003 – REVISED NOVEMBER 2010

### recommended operating conditions (see Note 4)

		MIN	TYP	MAX	UNIT
Supply voltage	V <sub>DDQ</sub>	2.3		2.7	V
	AV <sub>DD</sub>	V <sub>DDQ</sub> - 0.12		2.7	V
Low-level input voltage, V <sub>IL</sub>	CLK, $\overline{\text{CLK}}$ , FBIN, $\overline{\text{FBIN}}$	V <sub>DDQ</sub> /2 - 0.18			V
	PWRDWN	-0.3		0.7	
High-level input voltage, V <sub>IH</sub>	CLK, $\overline{\text{CLK}}$ , FBIN, $\overline{\text{FBIN}}$	V <sub>DDQ</sub> /2 + 0.18			V
	PWRDWN	1.7		V <sub>DDQ</sub> + 0.3	
DC input signal voltage (see Note 5)		-0.3		V <sub>DDQ</sub> + 0.3	V
Differential input signal voltage, V <sub>ID</sub> (see Note 6)	dc   CLK, FBIN	0.36		V <sub>DDQ</sub> + 0.6	V
	ac   CLK, FBIN	0.7		V <sub>DDQ</sub> + 0.6	
Input differential pair cross voltage, V <sub>IX</sub> (see Note 7)		V <sub>DDQ</sub> /2 - 0.2		V <sub>DDQ</sub> /2 + 0.2	V
High-level output current, I <sub>OH</sub>				-12	mA
Low-level output current, I <sub>OL</sub>				12	mA
Input slew rate, SR		1		4	V/ns
Operating free-air temperature, T <sub>A</sub>	Commercial	0		85	°C
	Industrial	-40		85	

- NOTES:
- The unused inputs must be held high or low to prevent them from floating.
  - The dc input signal voltage specifies the allowable dc execution of the differential input.
  - The differential input signal voltage specifies the differential voltage |V<sub>T</sub>R - V<sub>C</sub>P| required for switching, where V<sub>T</sub>R is the true input level and V<sub>C</sub>P is the complementary input level.
  - The differential cross-point voltage is expected to track variations of V<sub>CC</sub> and is the voltage at which the differential signals must be crossing.

### electrical characteristics over recommended operating free-air temperature range (unless otherwise noted)

PARAMETER		TEST CONDITIONS	MIN	TYP <sup>†</sup>	MAX	UNIT
V <sub>IK</sub>	Input voltage	All inputs V <sub>DDQ</sub> = 2.3 V, I <sub>I</sub> = -18 mA			-1.2	V
V <sub>OH</sub>	High-level output voltage	V <sub>DDQ</sub> = min to max, I <sub>OH</sub> = -1 mA	V <sub>DDQ</sub> - 0.1			V
		V <sub>DDQ</sub> = 2.3 V, I <sub>OH</sub> = -12 mA	1.7			
V <sub>OL</sub>	Low-level output voltage	V <sub>DDQ</sub> = min to max, I <sub>OL</sub> = 1 mA	0.1			V
		V <sub>DDQ</sub> = 2.3 V, I <sub>OL</sub> = 12 mA	0.6			
V <sub>OD</sub>	Output voltage swing <sup>‡</sup>	Differential outputs are terminated with 120 Ω /CL = 14 pF (See Figure 3)	1.1		V <sub>DDQ</sub> - 0.4	V
V <sub>OX</sub>	Output differential cross-voltage <sup>§</sup>		V <sub>DDQ</sub> /2 - 0.15	V <sub>DDQ</sub> /2	V <sub>DDQ</sub> /2 + 0.15	
I <sub>I</sub>	Input current	V <sub>DDQ</sub> = 2.7 V, V <sub>I</sub> = 0 V to 2.7 V			±10	μA
I <sub>OZ</sub>	High-impedance state output current	V <sub>DDQ</sub> = 2.7 V, V <sub>O</sub> = V <sub>DDQ</sub> or GND			±10	μA
I <sub>DDPD</sub>	Power-down current on V <sub>DDQ</sub> + AV <sub>DD</sub>	CLK and $\overline{\text{CLK}}$ = 0 MHz; PWRDWN = Low; Σ of I <sub>DD</sub> and A <sub>I</sub> DD		20	100	μA
A <sub>I</sub> DD	Supply current on AV <sub>DD</sub>	f <sub>O</sub> = 170 MHz		7	10	mA
		f <sub>O</sub> = 200 MHz		9	12	
C <sub>I</sub>	Input capacitance	V <sub>DDQ</sub> = 2.5 V, V <sub>I</sub> = V <sub>DDQ</sub> or GND	2	2.5	3.5	pF

<sup>†</sup> All typical values are at a respective nominal V<sub>DDQ</sub>.

<sup>‡</sup> The differential output signal voltage specifies the differential voltage |V<sub>T</sub>R - V<sub>C</sub>P|, where V<sub>T</sub>R is the true output level and V<sub>C</sub>P is the complementary output level.

<sup>§</sup> The differential cross-point voltage is expected to track variations of V<sub>DDQ</sub> and is the voltage at which the differential signals must be crossing. The frequency range is 100 MHz to 200 MHz.



# CDCV857B, CDCV857BI

## 2.5-V PHASE-LOCK LOOP CLOCK DRIVER

SCAS689A – FEBRUARY 2003 – REVISED NOVEMBER 2010

### electrical characteristics over recommended operating free-air temperature range (unless otherwise noted) (continued)

PARAMETER		TEST CONDITIONS	MIN	TYP <sup>†</sup>	MAX	UNIT
I <sub>DD</sub>	Dynamic current on V <sub>DDQ</sub>	Without load	f <sub>O</sub> = 170 MHz	100	110	mA
			f <sub>O</sub> = 200 MHz	105	120	
		Differential outputs terminated with 120 Ω/CL = 0 pF	f <sub>O</sub> = 170 MHz	200	240	
			f <sub>O</sub> = 200 MHz	210	250	
		Differential outputs terminated with 120 Ω/CL = 14 pF	f <sub>O</sub> = 170 MHz	260	300	
			f <sub>O</sub> = 200 MHz	280	320	
ΔC	Part-to-part input capacitance variation	V <sub>DDQ</sub> = 2.5 V, V <sub>I</sub> = V <sub>DDQ</sub> or GND			1	pF
C <sub>I(Δ)</sub>	Input capacitance difference between CLK and CLKB, FBIN, and FBINB	V <sub>DDQ</sub> = 2.5 V, V <sub>I</sub> = V <sub>DDQ</sub> or GND			0.25	pF
C <sub>O</sub>	Output capacitance	V <sub>DDQ</sub> = 2.5 V, V <sub>O</sub> = V <sub>DDQ</sub> or GND	2.5	3	3.5	pF

<sup>†</sup> All typical values are at a respective nominal V<sub>DDQ</sub>.

### timing requirements over recommended ranges of supply voltage and operating free-air temperature

		MIN	MAX	UNIT
f <sub>CLK</sub>	Operating clock frequency	60	200	MHz
	Application clock frequency			
Input clock duty cycle		40%	60%	
Stabilization time <sup>†</sup> (PLL mode)			10	μs
Stabilization time <sup>‡</sup> (Bypass mode)			30	ns

<sup>†</sup> The time required for the integrated PLL circuit to obtain phase lock of its feedback signal to its reference signal. For phase lock to be obtained, a fixed-frequency, fixed-phase reference signal must be present at CLK and V<sub>DD</sub> must be applied. Until phase lock is obtained, the specifications for propagation delay, skew, and jitter parameters given in the switching characteristics table are not applicable. This parameter does not apply for input modulation under SSC application.

<sup>‡</sup> A recovery time is required when the device goes from power-down mode into bypass mode (AVDD at GND).

### switching characteristics

PARAMETER		TEST CONDITIONS	MIN	TYP	MAX	UNIT
t <sub>PLH</sub> <sup>§</sup>	Low to high level propagation delay time	Test mode/CLK to any output		3.5		ns
t <sub>PHL</sub> <sup>§</sup>	High-to low level propagation delay time	Test mode/CLK to any output		3.5		ns
t <sub>jit(per)</sub> <sup>¶</sup>	Jitter (period), See Figure 7	66 MHz	-60		60	ps
		100/133/167/200 MHz	-35		35	ps
t <sub>jit(cc)</sub> <sup>¶</sup>	Jitter (cycle-to-cycle), See Figure 4	66 MHz	-75		75	ps
		100/133/167/200 MHz	-50		50	ps
t <sub>jit(hper)</sub> <sup>¶</sup>	Half-period jitter, See Figure 8	66 MHz	-100		100	ps
		100/133/167/200 MHz	-75		75	ps
t <sub>slr(o)</sub>	Output clock slew rate, See Figure 9	Load: 120 Ω/14 pF	1		2	V/ns
t <sub>(∅)</sub>	Static phase offset, See Figure 5	66 MHz	-100		100	ps
		100/133/167/200 MHz	-50		50	ps
t <sub>sk(o)</sub>	Output skew, See Figure 6	Load: 120 Ω/14 pF		70	100	ps
t <sub>r</sub> , t <sub>f</sub>	Output rise and fall times (20% – 80%)	Load: 120 Ω/14 pF	600		900	ps

<sup>§</sup> Refers to the transition of the noninverting output.

<sup>¶</sup> This parameter is assured by design but can not be 100% production tested.



PARAMETER MEASUREMENT INFORMATION

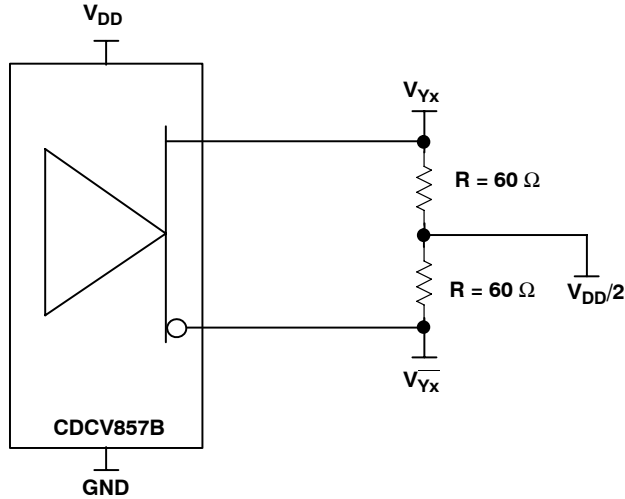

Figure 1. IBIS Model Output Load

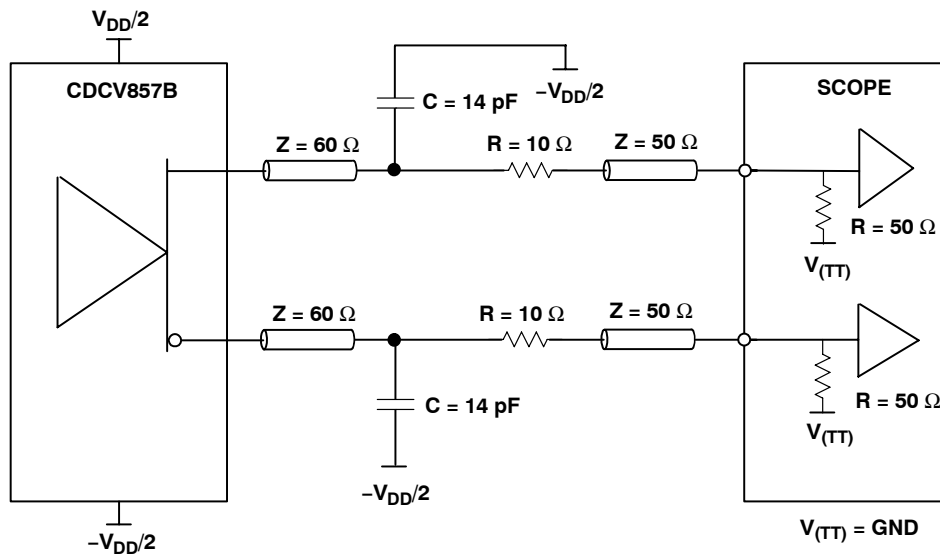

Figure 2. Output Load Test Circuit

# CDCV857B, CDCV857BI 2.5-V PHASE-LOCK LOOP CLOCK DRIVER

SCAS689A – FEBRUARY 2003 – REVISED NOVEMBER 2010

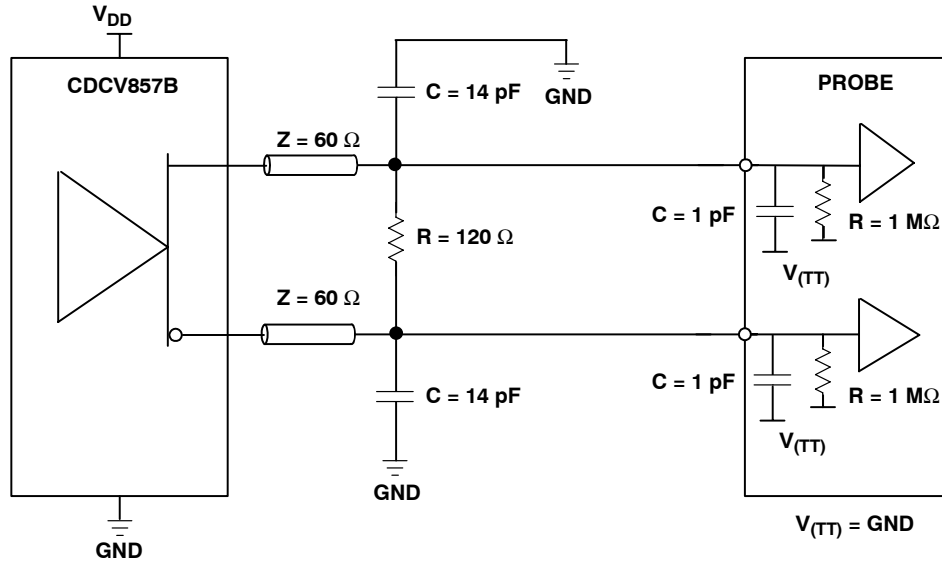

Figure 3. Output Load Test Circuit for Crossing Point

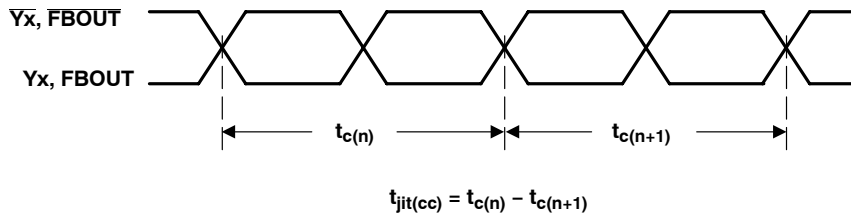

Figure 4. Cycle-to-Cycle Jitter

PARAMETER MEASUREMENT INFORMATION

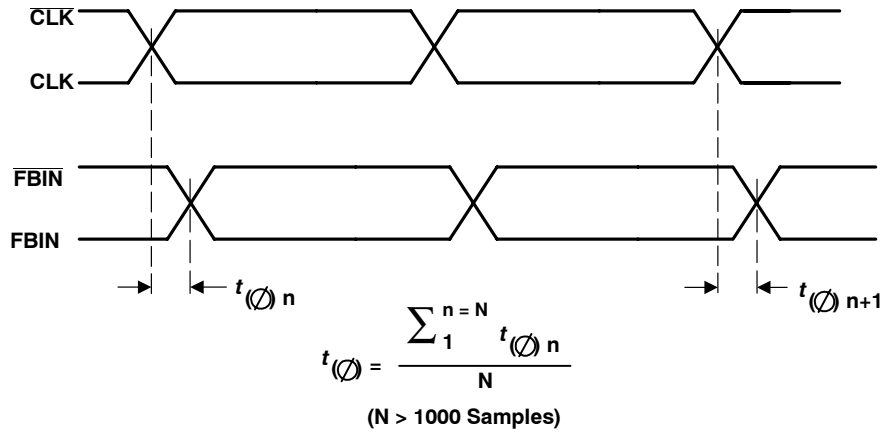

Figure 5. Phase Offset

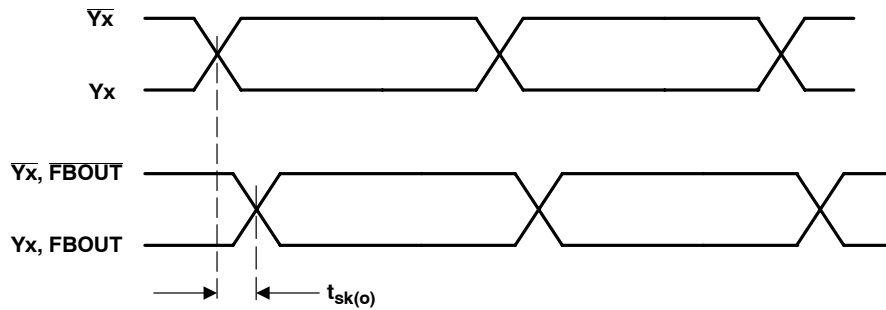

Figure 6. Output Skew

# CDCV857B, CDCV857BI

## 2.5-V PHASE-LOCK LOOP CLOCK DRIVER

SCAS689A – FEBRUARY 2003 – REVISED NOVEMBER 2010

### PARAMETER MEASUREMENT INFORMATION

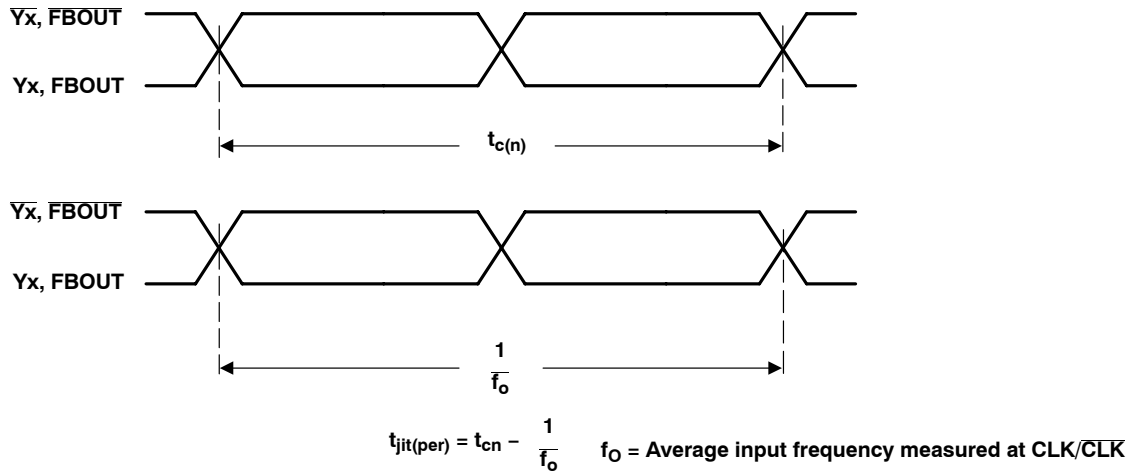

Figure 7. Period Jitter

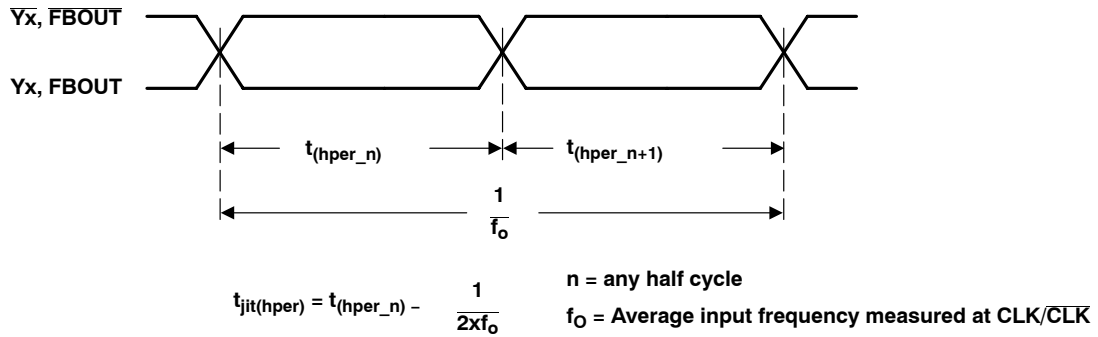

Figure 8. Half-Period Jitter

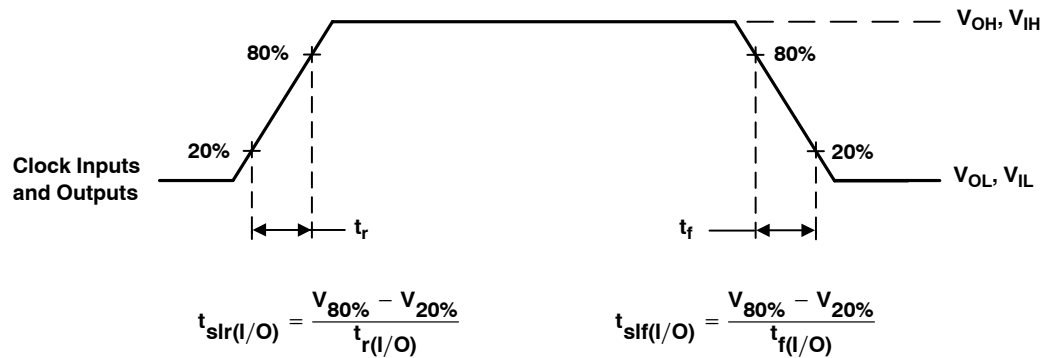

Figure 9. Input and Output Slew Rates

**PACKAGING INFORMATION**

Orderable Device	Status <sup>(1)</sup>	Package Type	Package Drawing	Pins	Package Qty	Eco Plan <sup>(2)</sup>	Lead/ Ball Finish	MSL Peak Temp <sup>(3)</sup>	Samples (Requires Login)
CDCV857BDGG	ACTIVE	TSSOP	DGG	48	40	Green (RoHS & no Sb/Br)	CU NIPDAU	Level-2-260C-1 YEAR	<a href="#">Request Free Samples</a>
CDCV857BDGGG4	ACTIVE	TSSOP	DGG	48	40	Green (RoHS & no Sb/Br)	CU NIPDAU	Level-2-260C-1 YEAR	<a href="#">Request Free Samples</a>
CDCV857BDGGGR	ACTIVE	TSSOP	DGG	48	2000	Green (RoHS & no Sb/Br)	CU NIPDAU	Level-2-260C-1 YEAR	<a href="#">Purchase Samples</a>
CDCV857BDGGRG4	ACTIVE	TSSOP	DGG	48	2000	Green (RoHS & no Sb/Br)	CU NIPDAU	Level-2-260C-1 YEAR	<a href="#">Purchase Samples</a>
CDCV857BGQLR	ACTIVE	BGA MICROSTAR JUNIOR	GQL	56	1000	TBD	SNPB	Level-2A-220C-4 WKS	<a href="#">Request Free Samples</a>
CDCV857BIDGG	ACTIVE	TSSOP	DGG	48	40	Green (RoHS & no Sb/Br)	CU NIPDAU	Level-2-260C-1 YEAR	<a href="#">Request Free Samples</a>
CDCV857BIDGGG4	ACTIVE	TSSOP	DGG	48	40	Green (RoHS & no Sb/Br)	CU NIPDAU	Level-2-260C-1 YEAR	<a href="#">Request Free Samples</a>
CDCV857BIDGGGR	ACTIVE	TSSOP	DGG	48	2000	Green (RoHS & no Sb/Br)	CU NIPDAU	Level-2-260C-1 YEAR	<a href="#">Purchase Samples</a>
CDCV857BIDGGRG4	ACTIVE	TSSOP	DGG	48	2000	Green (RoHS & no Sb/Br)	CU NIPDAU	Level-2-260C-1 YEAR	<a href="#">Purchase Samples</a>

<sup>(1)</sup> The marketing status values are defined as follows:

**ACTIVE:** Product device recommended for new designs.

**LIFEBUY:** TI has announced that the device will be discontinued, and a lifetime-buy period is in effect.

**NRND:** Not recommended for new designs. Device is in production to support existing customers, but TI does not recommend using this part in a new design.

**PREVIEW:** Device has been announced but is not in production. Samples may or may not be available.

**OBSELETE:** TI has discontinued the production of the device.

<sup>(2)</sup> Eco Plan - The planned eco-friendly classification: Pb-Free (RoHS), Pb-Free (RoHS Exempt), or Green (RoHS & no Sb/Br) - please check <http://www.ti.com/productcontent> for the latest availability information and additional product content details.

**TBD:** The Pb-Free/Green conversion plan has not been defined.

**Pb-Free (RoHS):** TI's terms "Lead-Free" or "Pb-Free" mean semiconductor products that are compatible with the current RoHS requirements for all 6 substances, including the requirement that lead not exceed 0.1% by weight in homogeneous materials. Where designed to be soldered at high temperatures, TI Pb-Free products are suitable for use in specified lead-free processes.

**Pb-Free (RoHS Exempt):** This component has a RoHS exemption for either 1) lead-based flip-chip solder bumps used between the die and package, or 2) lead-based die adhesive used between the die and leadframe. The component is otherwise considered Pb-Free (RoHS compatible) as defined above.

**Green (RoHS & no Sb/Br):** TI defines "Green" to mean Pb-Free (RoHS compatible), and free of Bromine (Br) and Antimony (Sb) based flame retardants (Br or Sb do not exceed 0.1% by weight in homogeneous material)

<sup>(3)</sup> MSL, Peak Temp. -- The Moisture Sensitivity Level rating according to the JEDEC industry standard classifications, and peak solder temperature.

**Important Information and Disclaimer:** The information provided on this page represents TI's knowledge and belief as of the date that it is provided. TI bases its knowledge and belief on information provided by third parties, and makes no representation or warranty as to the accuracy of such information. Efforts are underway to better integrate information from third parties. TI has taken and continues to take reasonable steps to provide representative and accurate information but may not have conducted destructive testing or chemical analysis on incoming materials and chemicals. TI and TI suppliers consider certain information to be proprietary, and thus CAS numbers and other limited information may not be available for release.

In no event shall TI's liability arising out of such information exceed the total purchase price of the TI part(s) at issue in this document sold by TI to Customer on an annual basis.

## TAPE AND REEL INFORMATION



### QUADRANT ASSIGNMENTS FOR PIN 1 ORIENTATION IN TAPE



\*All dimensions are nominal

Device	Package Type	Package Drawing	Pins	SPQ	Reel Diameter (mm)	Reel Width W1 (mm)	A0 (mm)	B0 (mm)	K0 (mm)	P1 (mm)	W (mm)	Pin1 Quadrant
CDCV857BDGGR	TSSOP	DGG	48	2000	330.0	24.4	8.6	15.8	1.8	12.0	24.0	Q1
CDCV857BGQLR	BGA MICROSTAR JUNIOR	GQL	56	1000	330.0	16.4	4.8	7.3	1.45	8.0	16.0	Q1
CDCV857BIDGGR	TSSOP	DGG	48	2000	330.0	24.4	8.6	15.8	1.8	12.0	24.0	Q1

## TAPE AND REEL BOX DIMENSIONS



\*All dimensions are nominal

Device	Package Type	Package Drawing	Pins	SPQ	Length (mm)	Width (mm)	Height (mm)
CDCV857BDGGR	TSSOP	DGG	48	2000	346.0	346.0	41.0
CDCV857BGQLR	BGA MICROSTAR JUNIOR	GQL	56	1000	346.0	346.0	33.0
CDCV857BIDGGR	TSSOP	DGG	48	2000	346.0	346.0	41.0

GQL (R-PBGA-N56)

PLASTIC BALL GRID ARRAY

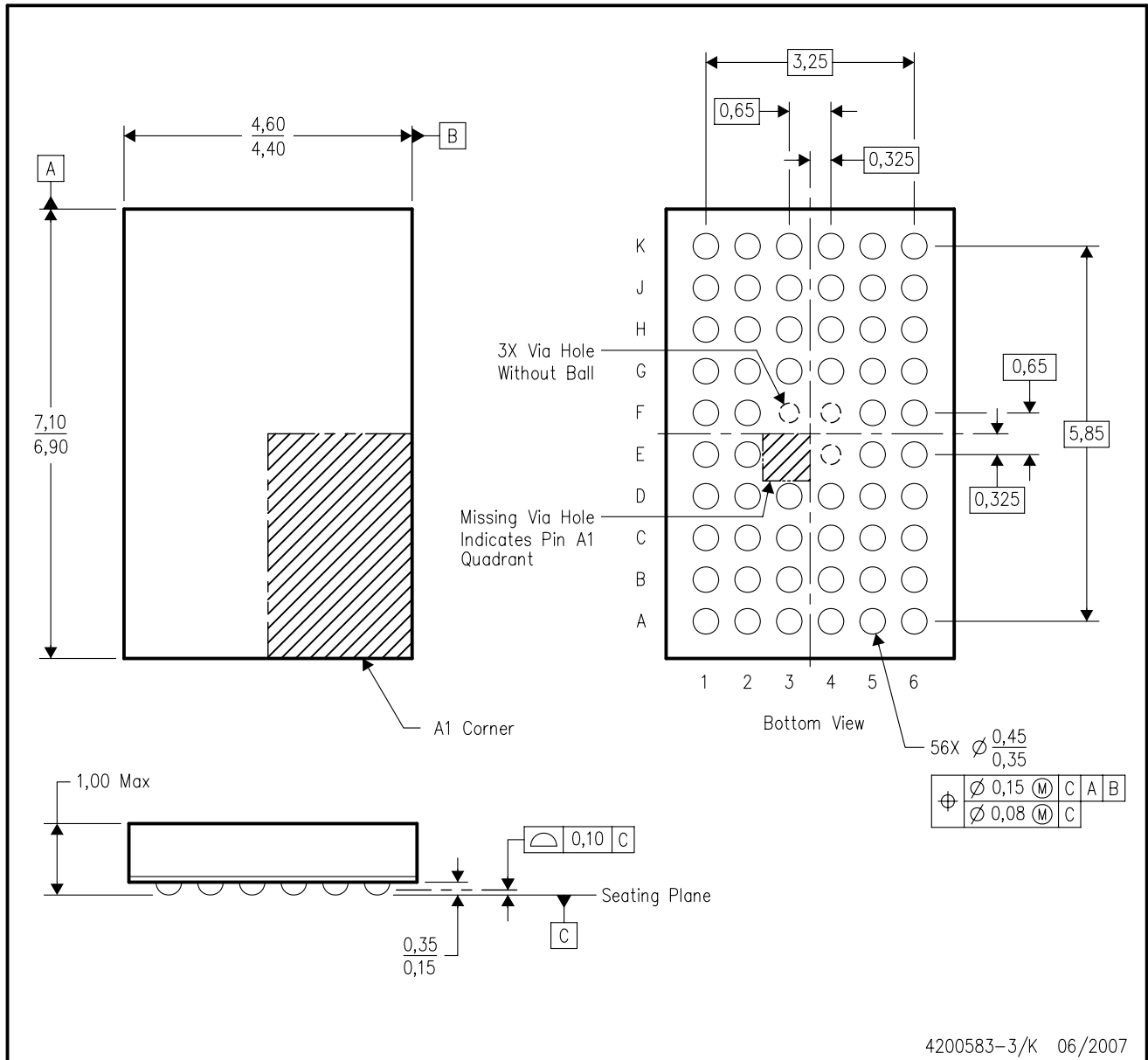

- NOTES:
- A. All linear dimensions are in millimeters. Dimensioning and tolerancing per ASME Y14.5M-1994.
  - B. This drawing is subject to change without notice.
  - C. Falls within JEDEC MO-285 variation BA-2.
  - D. This package is tin-lead (SnPb). Refer to the 56 ZQL package (drawing 4204437) for lead-free.

DGG (R-PDSO-G\*\*)

PLASTIC SMALL-OUTLINE PACKAGE

48 PINS SHOWN



- NOTES: A. All linear dimensions are in millimeters.  
 B. This drawing is subject to change without notice.  
 C. Body dimensions do not include mold protrusion not to exceed 0,15.  
 D. Falls within JEDEC MO-153

## IMPORTANT NOTICE

Texas Instruments Incorporated and its subsidiaries (TI) reserve the right to make corrections, modifications, enhancements, improvements, and other changes to its products and services at any time and to discontinue any product or service without notice. Customers should obtain the latest relevant information before placing orders and should verify that such information is current and complete. All products are sold subject to TI's terms and conditions of sale supplied at the time of order acknowledgment.

TI warrants performance of its hardware products to the specifications applicable at the time of sale in accordance with TI's standard warranty. Testing and other quality control techniques are used to the extent TI deems necessary to support this warranty. Except where mandated by government requirements, testing of all parameters of each product is not necessarily performed.

TI assumes no liability for applications assistance or customer product design. Customers are responsible for their products and applications using TI components. To minimize the risks associated with customer products and applications, customers should provide adequate design and operating safeguards.

TI does not warrant or represent that any license, either express or implied, is granted under any TI patent right, copyright, mask work right, or other TI intellectual property right relating to any combination, machine, or process in which TI products or services are used. Information published by TI regarding third-party products or services does not constitute a license from TI to use such products or services or a warranty or endorsement thereof. Use of such information may require a license from a third party under the patents or other intellectual property of the third party, or a license from TI under the patents or other intellectual property of TI.

Reproduction of TI information in TI data books or data sheets is permissible only if reproduction is without alteration and is accompanied by all associated warranties, conditions, limitations, and notices. Reproduction of this information with alteration is an unfair and deceptive business practice. TI is not responsible or liable for such altered documentation. Information of third parties may be subject to additional restrictions.

Resale of TI products or services with statements different from or beyond the parameters stated by TI for that product or service voids all express and any implied warranties for the associated TI product or service and is an unfair and deceptive business practice. TI is not responsible or liable for any such statements.

TI products are not authorized for use in safety-critical applications (such as life support) where a failure of the TI product would reasonably be expected to cause severe personal injury or death, unless officers of the parties have executed an agreement specifically governing such use. Buyers represent that they have all necessary expertise in the safety and regulatory ramifications of their applications, and acknowledge and agree that they are solely responsible for all legal, regulatory and safety-related requirements concerning their products and any use of TI products in such safety-critical applications, notwithstanding any applications-related information or support that may be provided by TI. Further, Buyers must fully indemnify TI and its representatives against any damages arising out of the use of TI products in such safety-critical applications.

TI products are neither designed nor intended for use in military/aerospace applications or environments unless the TI products are specifically designated by TI as military-grade or "enhanced plastic." Only products designated by TI as military-grade meet military specifications. Buyers acknowledge and agree that any such use of TI products which TI has not designated as military-grade is solely at the Buyer's risk, and that they are solely responsible for compliance with all legal and regulatory requirements in connection with such use.

TI products are neither designed nor intended for use in automotive applications or environments unless the specific TI products are designated by TI as compliant with ISO/TS 16949 requirements. Buyers acknowledge and agree that, if they use any non-designated products in automotive applications, TI will not be responsible for any failure to meet such requirements.

Following are URLs where you can obtain information on other Texas Instruments products and application solutions:

<b>Products</b>		<b>Applications</b>	
Amplifiers	<a href="http://amplifier.ti.com">amplifier.ti.com</a>	Audio	<a href="http://www.ti.com/audio">www.ti.com/audio</a>
Data Converters	<a href="http://dataconverter.ti.com">dataconverter.ti.com</a>	Automotive	<a href="http://www.ti.com/automotive">www.ti.com/automotive</a>
DLP® Products	<a href="http://www.dlp.com">www.dlp.com</a>	Communications and Telecom	<a href="http://www.ti.com/communications">www.ti.com/communications</a>
DSP	<a href="http://dsp.ti.com">dsp.ti.com</a>	Computers and Peripherals	<a href="http://www.ti.com/computers">www.ti.com/computers</a>
Clocks and Timers	<a href="http://www.ti.com/clocks">www.ti.com/clocks</a>	Consumer Electronics	<a href="http://www.ti.com/consumer-apps">www.ti.com/consumer-apps</a>
Interface	<a href="http://interface.ti.com">interface.ti.com</a>	Energy	<a href="http://www.ti.com/energy">www.ti.com/energy</a>
Logic	<a href="http://logic.ti.com">logic.ti.com</a>	Industrial	<a href="http://www.ti.com/industrial">www.ti.com/industrial</a>
Power Mgmt	<a href="http://power.ti.com">power.ti.com</a>	Medical	<a href="http://www.ti.com/medical">www.ti.com/medical</a>
Microcontrollers	<a href="http://microcontroller.ti.com">microcontroller.ti.com</a>	Security	<a href="http://www.ti.com/security">www.ti.com/security</a>
RFID	<a href="http://www.ti-rfid.com">www.ti-rfid.com</a>	Space, Avionics & Defense	<a href="http://www.ti.com/space-avionics-defense">www.ti.com/space-avionics-defense</a>
RF/IF and ZigBee® Solutions	<a href="http://www.ti.com/lprf">www.ti.com/lprf</a>	Video and Imaging	<a href="http://www.ti.com/video">www.ti.com/video</a>
		Wireless	<a href="http://www.ti.com/wireless-apps">www.ti.com/wireless-apps</a>

Mailing Address: Texas Instruments, Post Office Box 655303, Dallas, Texas 75265  
Copyright © 2010, Texas Instruments Incorporated