

FEATURES

- 1.8-V Phase Lock Loop Clock Driver for Double Data Rate (DDR II) Applications
- Spread Spectrum Clock Compatible
- Operating Frequency: 10 MHz to 400 MHz
- Low Current Consumption: <135 mA
- Low Jitter (Cycle-Cycle): ± 30 ps
- Low Output Skew: 35 ps
- Low Period Jitter: ± 20 ps
- Low Dynamic Phase Offset: ± 15 ps
- Low Static Phase Offset: ± 50 ps
- Distributes One Differential Clock Input to Ten Differential Outputs
- 52-Ball μ BGA (MicroStar™ Junior BGA, 0,65-mm pitch) and 40-Pin MLF
- External Feedback Pins (FBIN, $\overline{\text{FBIN}}$) are Used to Synchronize the Outputs to the Input Clocks
- Meets or Exceeds JESD82-8 PLL Standard for PC2-3200/4300
- Fail-Safe Inputs

DESCRIPTION

The CDCU877 is a high-performance, low-jitter, low-skew, zero-delay buffer that distributes a differential clock input pair (CK, $\overline{\text{CK}}$) to ten differential pairs of clock outputs (Y_n , $\overline{Y_n}$) and to one differential pair of feedback clock outputs (FBOUT, $\overline{\text{FBOUT}}$). The clock outputs are controlled by the input clocks (CK, $\overline{\text{CK}}$), the feedback clocks (FBIN, $\overline{\text{FBIN}}$), the LVCMOS control pins (OE, OS), and the analog power input (AV_{DD}). When OE is low, the clock outputs, except FBOUT/ $\overline{\text{FBOUT}}$, are disabled while the internal PLL continues to maintain its locked-in frequency. OS (output select) is a program pin that must be tied to GND or V_{DD} . When OS is high, OE functions as previously described. When OS and OE are both low, OE has no effect on $Y7/\overline{Y7}$, they are free running. When AV_{DD} is grounded, the PLL is turned off and bypassed for test purposes.

When both clock inputs (CK, $\overline{\text{CK}}$) are logic low, the device enters in a low power mode. An input logic detection circuit on the differential inputs, independent from input buffers, detects the logic low level and performs in a low power state where all outputs, the feedback, and the PLL are off. When the clock inputs transition from being logic low to being differential signals, the PLL turns back on, the inputs and the outputs are enabled, and the PLL obtains phase lock between the feedback clock pair (FBIN, $\overline{\text{FBIN}}$) and the clock input pair (CK, $\overline{\text{CK}}$) within the specified stabilization time.

The CDCU877 is able to track spread spectrum clocking (SSC) for reduced EMI. This device operates from -40°C to 85°C .

ORDERING INFORMATION

T_A	52-BALL BGA ⁽¹⁾	40-Pin MLF
-40°C to 85°C	CDCU877ZQL	CDCU877RHA
	CDCU877AZQL	CDCU877ARHA
	CDCU877GQL	CDCU877RTB
	CDCU877AGQL	CDCU877ARTB

- (1) For the most current package and ordering information, see the Package Option Addendum at the end of this document, or see the TI website at www.ti.com.



Please be aware that an important notice concerning availability, standard warranty, and use in critical applications of Texas Instruments semiconductor products and disclaimers thereto appears at the end of this data sheet.

MicroStar is a trademark of Texas Instruments.

1.8-V PHASE LOCK LOOP CLOCK DRIVER

SCAS688D–JUNE 2005–REVISED JULY 2007



These devices have limited built-in ESD protection. The leads should be shorted together or the device placed in conductive foam during storage or handling to prevent electrostatic damage to the MOS gates.

**MicroStar Junior (ZQL) Package
(TOP VIEW)**

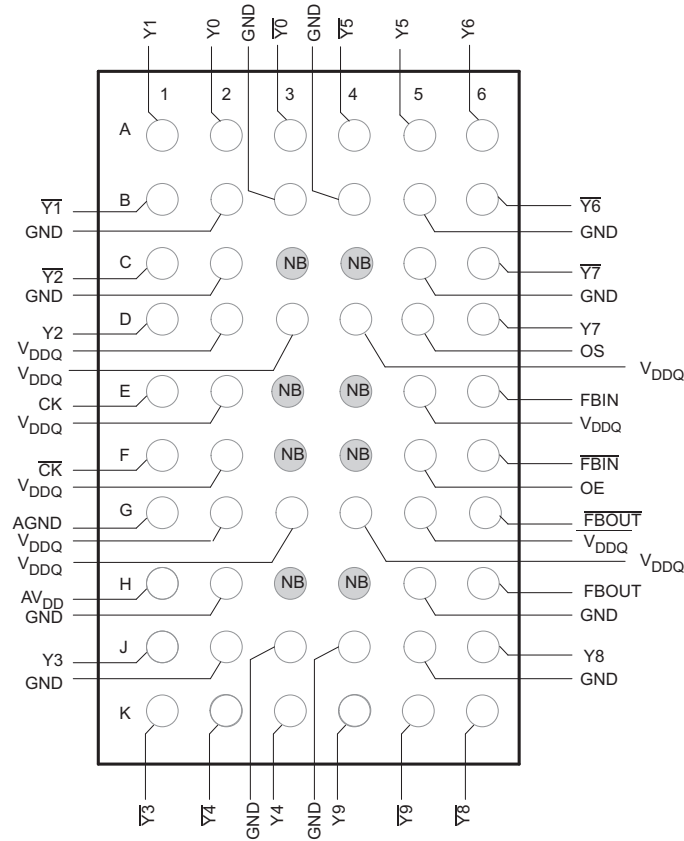

- A. NC = No Connection
- B. NB = No Ball

**RHA/RTB Package (MLF Package)
(TOP VIEW)**

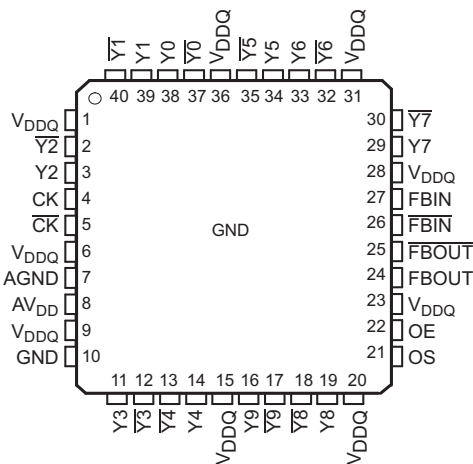

40-pin HP-VFQFP-N (6,0 x 6,0 mm Body Size,
0,5 mm Pitch, M0#220, Variation VJJD-2,
E2 = D2 = 2,9 mm ± 0,15 mm) Package Pinouts

1.8-V PHASE LOCK LOOP CLOCK DRIVER

SCAS688D–JUNE 2005–REVISED JULY 2007

TERMINAL FUNCTIONS

TERMINAL			I/O	DESCRIPTION
NAME	GQL/ZQL	RHA/RTB		
AGND	G1	7		Analog ground
AV _{DD}	H1	8		Analog power
CK	E1	4	I	Clock input with a (10 kΩ to 100 kΩ) pulldown resistor
$\overline{\text{CK}}$	F1	5	I	Complementary clock input with a (10 kΩ to 100 kΩ) pulldown resistor
FBIN	E6	27	I	Feedback clock input
$\overline{\text{FBIN}}$	F6	26	I	Complementary feedback clock input
FBOU _T	H6	24	O	Feedback clock output
$\overline{\text{FBOU}}\overline{\text{T}}$	G6	25	O	Complementary feedback clock output
OE	F5	22	I	Output enable (asynchronous)
OS	D5	21	I	Output select (tied to GND or V _{DD})
GND	B2, B3, B4, B5, C2, C5, H2, H5, J2, J3, J4, J5	10		Ground
V _{DDQ}	D2, D3, D4, E2, E5, F2, G2, G3, G4, G5	1, 6, 9, 15, 20, 23, 28, 31, 36		Logic and output power
Y[0:9]	A2, A1, D1, J1, K3, A5, A6, D6, J6, K4	3, 11, 14, 16, 19, 29, 33, 34, 38, 39	O	Clock outputs
$\overline{\text{Y}}[0:9]$	A3, B1, C1, K1, K2, A4, B6, C6, K6, K5	2, 12, 13, 18, 17, 30, 32, 35, 37, 40	O	Complementary clock outputs

FUNCTION TABLE

INPUTS					OUTPUTS				
AVDD	OE	OS	CK	$\overline{\text{CK}}$	Y	$\overline{\text{Y}}$	FBOU _T	$\overline{\text{FBOU}}\overline{\text{T}}$	PLL
GND	H	X	L	H	L	H	L	H	Bypassed/Off
GND	H	X	H	L	H	L	H	L	Bypassed/Off
GND	L	H	L	H	L _Z	L _Z	L	H	Bypassed/Off
GND	L	L	H	L	L _Z Y7 Active	L _Z $\overline{\text{Y}}\overline{7}$ Active	H	L	Bypassed/Off
1.8 V Nominal	L	H	L	H	L _Z	L _Z	L	H	On
1.8 V Nominal	L	L	H	L	L _Z Y7 Active	L _Z $\overline{\text{Y}}\overline{7}$ Active	H	L	On
1.8 V Nominal	H	X	L	H	L	H	L	H	On
1.8 V Nominal	H	X	H	L	H	L	H	L	On
1.8 V Nominal	X	X	L	L	L _Z	L _Z	L _Z	L _Z	Off
X	X	X	H	H	Reserved				

1.8-V PHASE LOCK LOOP CLOCK DRIVER

SCAS688D-JUNE 2005-REVISED JULY 2007

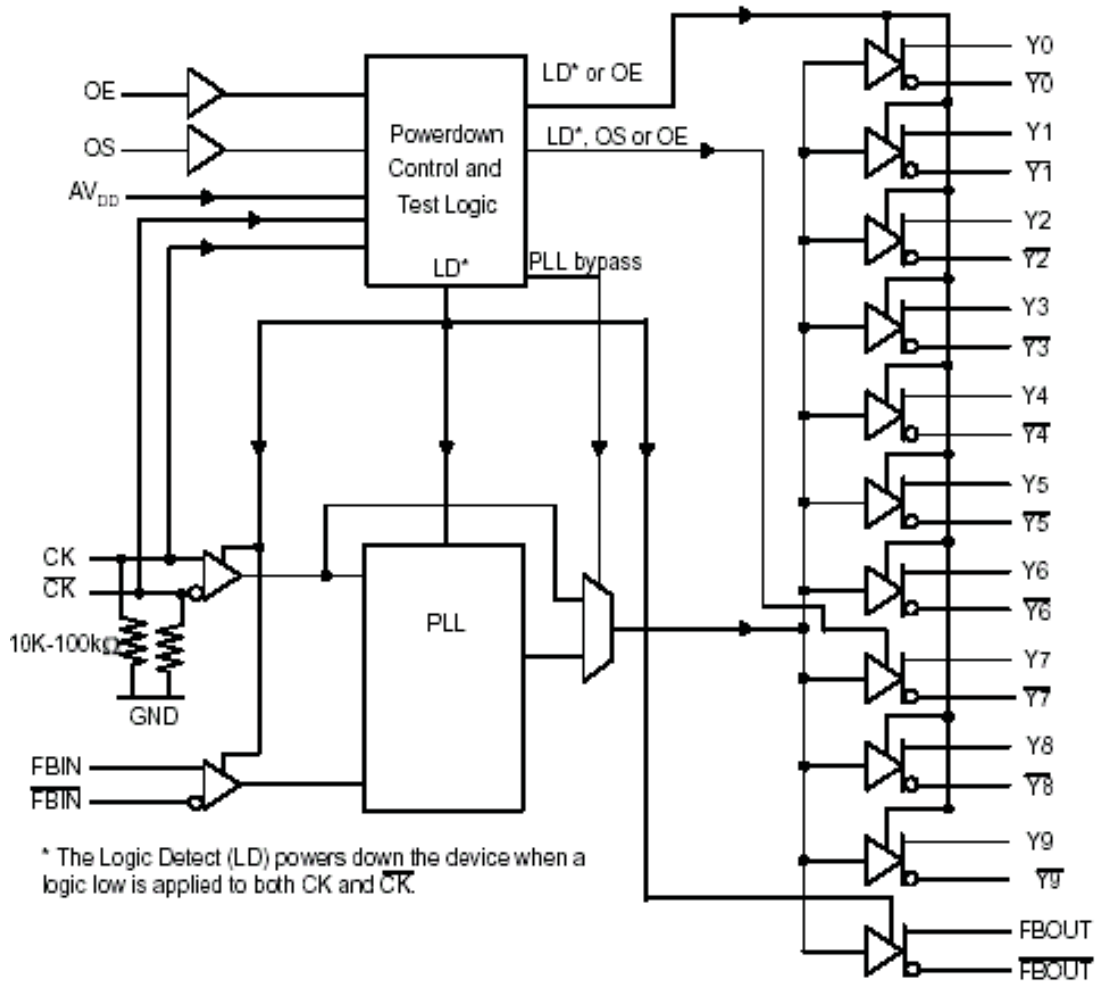

Figure 1. LOGIC DIAGRAM (POSITIVE LOGIC)

Absolute Maximum Ratings⁽¹⁾

over operating free-air temperature range (unless otherwise noted)

			MIN	MAX	UNIT
V _{CC}	Supply voltage range	V _{DDQ} or AV _{DD}	-0.5	2.5	V
V _I	Input voltage range ⁽²⁾⁽³⁾		-0.5	V _{DDQ} + 0.5	V
V _O	Output voltage range ⁽²⁾⁽³⁾		-0.5	V _{DDQ} + 0.5	V
I _{IK}	Input clamp current	V _I < 0 or V _I > V _{DDQ}		±50	mA
I _{OK}	Output clamp current	V _O < 0 or V _O > V _{DDQ}		±50	mA
I _O	Continuous output current	V _O = 0 to V _{DDQ}		±50	mA
		Continuous current through each V _{DDQ} or GND		±100	mA
T _{stg}	Storage temperature range		-65	150	°C

- (1) Stresses beyond those listed under "absolute maximum ratings" may cause permanent damage to the device. These are stress ratings only, and functional operation of the device at these or any other conditions beyond those indicated under "recommended operating conditions" is not implied. Exposure to absolute-maximum-rated conditions for extended periods may affect device reliability.
- (2) The input and output voltage ratings may be exceeded if the input and output clamp-current ratings are observed.
- (3) This value is limited to 2.5 V maximum.

Recommended Operating Conditions

			MIN	NOM	MAX	UNIT
V _{CC}	Output supply voltage, V _{DDQ}		1.7	1.8	1.9	V
	Supply Voltage, AV _{DD} ⁽¹⁾			V _{DDQ}		V
V _{IL}	Low-level input voltage ⁽²⁾	OE, OS			0.35 x V _{DDQ}	V
V _{IH}	High-level input voltage ⁽²⁾	CK, \overline{CK}	0.65 x V _{DDQ}			V
I _{OH}	High-level output current (see Figure 2)				-9	mA
I _{OL}	Low-level output current (see Figure 2)				9	mA
V _{IX}	Input differential-pair cross voltage		(V _{DDQ} /2) - 0.15		(V _{DDQ} /2) + 0.15	V
V _I	Input voltage level		-0.3		V _{DDQ} + 0.3	V
V _{ID}	Input differential voltage ⁽²⁾ (see Figure 9)	DC	0.3		V _{DDQ} + 0.4	V
		AC	0.6		V _{DDQ} + 0.4	V
T _A	Operating free-air temperature		-40		85	°C

- (1) The PLL is turned off and bypassed for test purposes when AV_{DD} is grounded. During this test mode, V_{DDQ} remains within the recommended operating conditions and no timing parameters are specified.
- (2) V_{ID} is the magnitude of the difference between the input level on CK and the input level on \overline{CK} , see Figure 9 for definition. The CK and \overline{CK} , V_{IH} and V_{IL} limits define the dc low and high levels for the logic detect state.

1.8-V PHASE LOCK LOOP CLOCK DRIVER

SCAS688D–JUNE 2005–REVISED JULY 2007

Electrical Characteristics

over recommended operating free-air temperature range (unless otherwise noted)

PARAMETER		TEST CONDITIONS	AV _{DD} , V _{DDQ}	MIN	TYP ⁽¹⁾	MAX	UNIT
V _{IK}	Input	I _I = 18 mA	1.7			-1.2	V
V _{OH}	High-level output voltage	I _{OH} = -100 μA	1.7 to 1.9	V _{DDQ} - 0.2			V
		I _{OH} = -9 mA	1.7	1.1			
V _{OL}	Low-level output voltage	I _{OL} = 100 μA				0.1	V
		I _{OL} = 9 mA	1.7			0.6	
I _{O(DL)}	Low-level output current, disabled	V _{O(DL)} = 100 mV, OE = L	1.7	100			μA
V _{OD}	Differential output voltage ⁽¹⁾		1.7	0.5			V
I _I	Input current	CK, \overline{CK}	1.9			±250	μA
		OE, OS, FBIN, \overline{FBIN}	1.9			±10	
I _{DD(LD)}	Supply current, static (I _{DDQ} + I _{ADD})	CK and \overline{CK} = L	1.9			500	μA
I _{DD}	Supply current, dynamic (I _{DDQ} + I _{ADD}) (see Note ⁽²⁾ for CPD calculation)	CK and \overline{CK} = 270 MHz. All outputs are open (not connected to a PCB)	1.9			135	mA
		All outputs are loaded with 2 pF and 120-Ω termination resistor	1.9			235	
C _I	Input capacitance	CK, \overline{CK}	V _I = V _{DD} or GND	1.8	2	3	pF
		FBIN, \overline{FBIN}		1.8	2	3	
C _{I(Δ)}	Change in input current	CK, \overline{CK}	V _I = V _{DD} or GND	1.8		0.25	pF
		FBIN, \overline{FBIN}		1.8		0.25	

(1) V_{OD} is the magnitude of the difference between the true and complimentary outputs. See Figure 9 for a definition.

(2) Total I_{DD} = I_{DDQ} + I_{ADD} = f_{CK} × C_{PD} × V_{DDQ}, solving for C_{PD} = (I_{DDQ} + I_{ADD})/(f_{CK} × V_{DDQ}) where f_{CK} is the input frequency, V_{DDQ} is the power supply, and C_{PD} is the power dissipation capacitance.

Timing Requirements

over recommended operating free-air temperature range (unless otherwise noted)⁽¹⁾

PARAMETER		TEST CONDITIONS	MIN	MAX	UNIT
f _{CK}	Clock frequency (operating) ⁽¹⁾⁽²⁾	AV _{DD} , V _{DD} = 1.8 V ±0.1 V	10	400	MHz
	Clock frequency (application) ⁽¹⁾⁽³⁾		160	340	MHz
t _{DC}	Duty cycle, input clock		40%	60%	
t _L	Stabilization time ⁽⁴⁾			12	μs

(1) The PLL must be able to handle spread spectrum induced skew.

(2) Operating clock frequency indicates a range over which the PLL must be able to lock, but in which it is not required to meet the other timing parameters (used for low speed system debug).

(3) Application clock frequency indicates a range over which the PLL must meet all timing parameters.

(4) Stabilization time is the time required for the integrated PLL circuit to obtain phase lock of its feedback signal to its reference signal after power up. During normal operation, the stabilization time is also the time required for the integrated PLL circuit to obtain phase lock of its feedback signal to its reference signal when CK and \overline{CK} go to a logic low state, enter the power-down mode and later return to active operation. CK and \overline{CK} may be left floating after they have been driven low for one complete clock cycle.

Switching Characteristics

over recommended operating free-air temperature range (unless otherwise noted) (see ⁽¹⁾) $AV_{DD}, V_{DD} = 1.8\text{ V} \pm 0.1\text{ V}$

PARAMETER		TEST CONDITIONS	MIN	TYP	MAX	UNIT
t_{en}	Enable time, OE to any Y/\bar{Y}	See Figure 11			8	ns
t_{dis}	Disable time, OE to any Y/\bar{Y}	See Figure 11			8	ns
$t_{jit(cc+)}$ $t_{jit(cc-)}$	Cycle-to-cycle period jitter ⁽²⁾	160 MHz to 190 MHz, see Figure 4	0		40	ps
			0		-40	
$t_{jit(cc+)}$ $t_{jit(cc-)}$	Cycle-to-cycle period jitter ⁽²⁾	160 MHz to 340 MHz, see Figure 4	0		30	ps
			0		-30	
$t_{(w)}$	Static phase offset time ⁽³⁾	See Figure 5	-50		50	ps
$t_{(w)dyn}$	Dynamic phase offset time	See Figure 10	-15		15	ps
$t_{sk(o)}$	Output clock skew	See Figure 6			35	ps
$t_{jit(per)}$	Period jitter ⁽⁴⁾⁽²⁾	160 MHz to 190 MHz, see Figure 7	-30		30	ps
		190 MHz to 340 MHz, see Figure 7	-20		20	
$t_{jit(hper)}$	Half-period jitter ⁽⁴⁾⁽²⁾	160 MHz to 190 MHz, see Figure 8	-115		115	ps
		190 MHz to 250 MHz, see Figure 8	-70		70	
		250 MHz to 300 MHz, see Figure 8	-40		40	
		300 MHz to 340 MHz, see Figure 8	-60		60	
SR	Slew rate, OE	See Figure 3 and Figure 9	0.5			V/ns
	Input clock slew rate	See Figure 3 and Figure 9	1	2.5	4	
	Output clock slew rate ⁽⁵⁾⁽⁶⁾ (no load)	See Figure 3 and Figure 9	1.5	2.5	3	
V_{OX}	Output differential-pair cross voltage ⁽⁷⁾	CDCU877, See Figure 2	$(V_{DDQ}/2) - 0.1$		$(V_{DDQ}/2) + 0.1$	V
		CDCU877A ⁽⁸⁾ , See Figure 2 (0 - 85°C)	$(V_{DDQ}/2) - 0.1$		$(V_{DDQ}/2) + 0.1$	
	SSC modulation frequency		30		33	kHz
	SSC clock input frequency deviation		0%		-0.5%	
	PLL loop bandwidth		2			MHz

- (1) There are two different terminations that are used with the following tests. The load/board in [Figure 2](#) is used to measure the input and output differential-pair cross voltage only. The load/board in [Figure 3](#) is used to measure all other tests. For consistency, equal length cables must be used.
- (2) This parameter is specified by design and characterization.
- (3) Phase static offset time does not include jitter.
- (4) Period jitter, half-period jitter specifications are separate specifications that must be met independently of each other.
- (5) The output slew rate is determined from the IBIS model with a 120- Ω load only.
- (6) To eliminate the impact of input slew rates on static phase offset, the input skew rates of reference clock input CK and \bar{CK} and feedback clock inputs FBIN and \bar{FBIN} are recommended to be nearly equal. The 2.5-V/ns skew rates are shown as a recommended target. Compliance with these typical values is not mandatory if it can adequately shown that alternative characteristics meet the requirements of the registered DDR2 DIMM application.
- (7) Output differential-pair cross voltage specified at the DRAM clock input or the test load.
- (8) V_{OX} of CDCU877A is on average 30 mV lower than that of CDCU877 for the same application.

1.8-V PHASE LOCK LOOP CLOCK DRIVER

SCAS688D–JUNE 2005–REVISED JULY 2007

PARAMETER MEASUREMENT INFORMATION

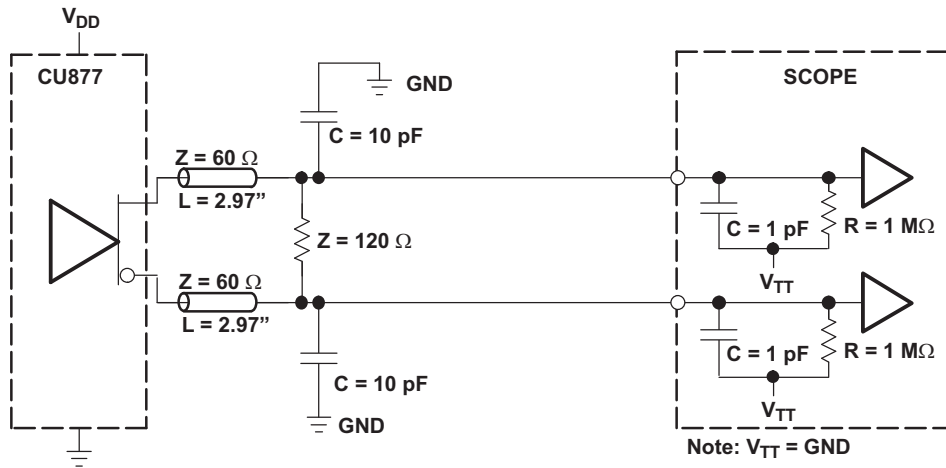

Figure 2. Output Load Test Circuit 1

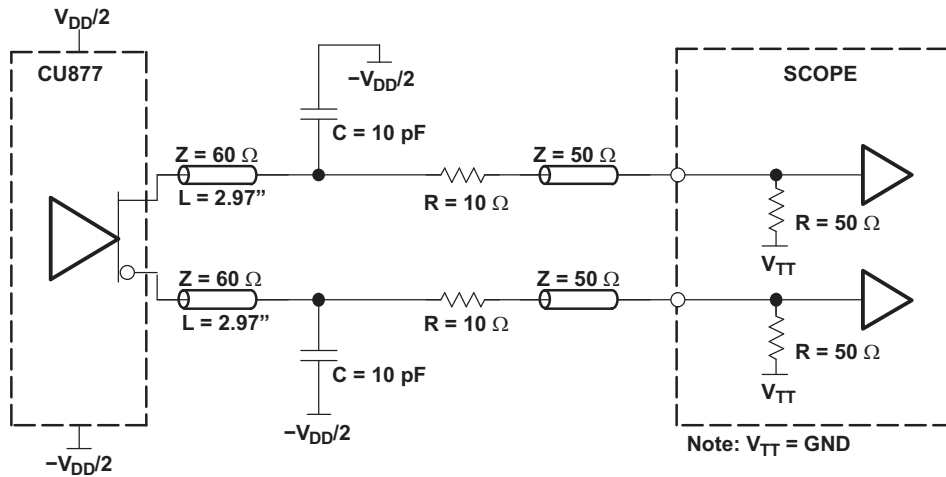

Figure 3. Output Load Test Circuit 2

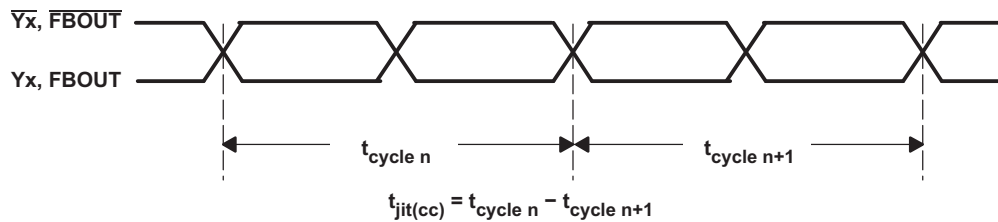

Figure 4. Cycle-To-Cycle Period Jitter

PARAMETER MEASUREMENT INFORMATION (continued)

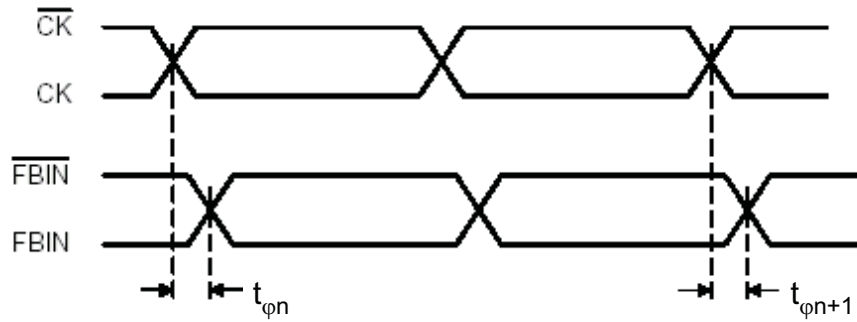

Figure 5. Static Phase Offset

$$t_{\phi} = \frac{\sum_{n=1}^N t_{\phi n}}{N}$$

(N is the large number of samples)

(N > 1000 samples)

(1)

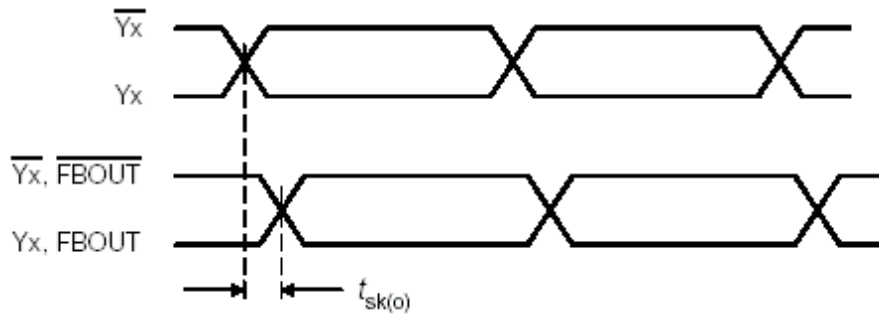

Figure 6. Output Skew

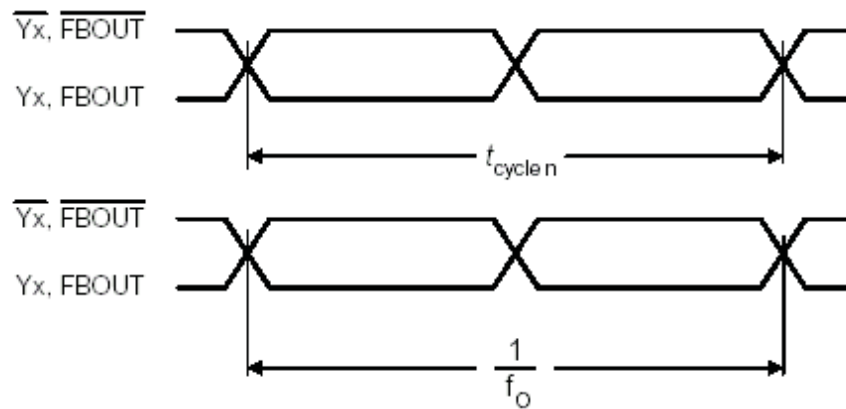

Figure 7. Period Jitter

$$t_{jit(per)} = t_{cycle\ n} - \frac{1}{f_o}$$

(f_o average input frequency measured at CK/ \overline{CK})

(2)

1.8-V PHASE LOCK LOOP CLOCK DRIVER

SCAS688D–JUNE 2005–REVISED JULY 2007

PARAMETER MEASUREMENT INFORMATION (continued)

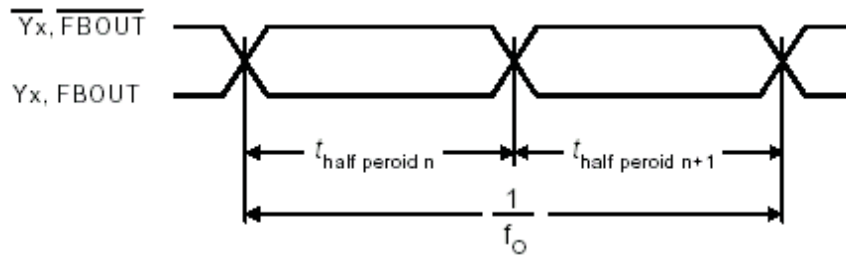

Figure 8. Half-Period Jitter

$$t_{jit(hper)} = t_{half\ period\ n} - \frac{1}{2 \times f_0}$$

n = any half cycle

(f₀ average input frequency measured at CK/ \overline{CK})

(3)

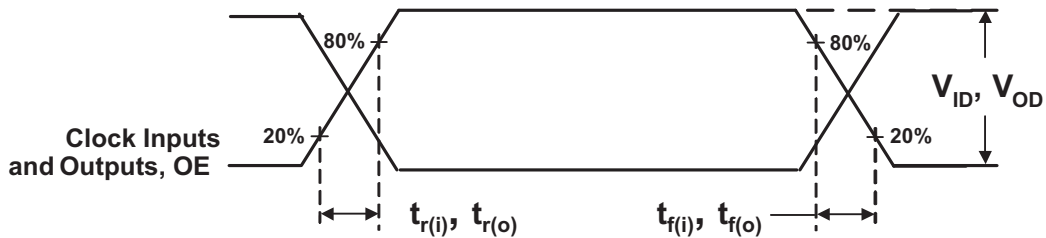

Figure 9. Input and Output Slew Rates

$$slrr_{(i/o)} = \frac{V_{80\%} - V_{20\%}}{t_{r(i/o)}}$$

$$slrf_{(i/o)} = \frac{V_{80\%} - V_{20\%}}{t_{f(i/o)}}$$

(4)

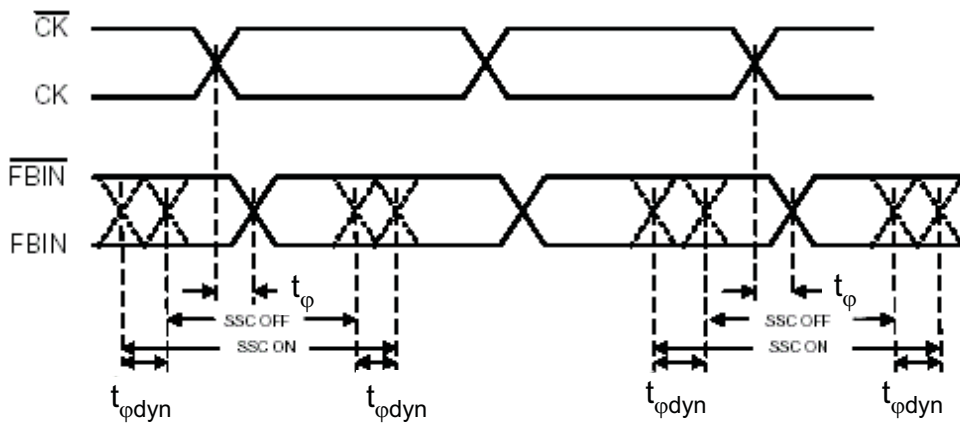

Figure 10. Dynamic Phase Offset

PARAMETER MEASUREMENT INFORMATION (continued)

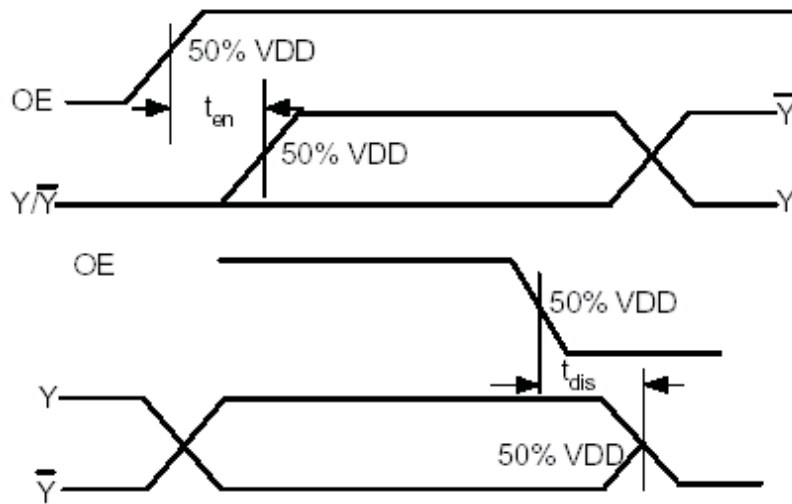
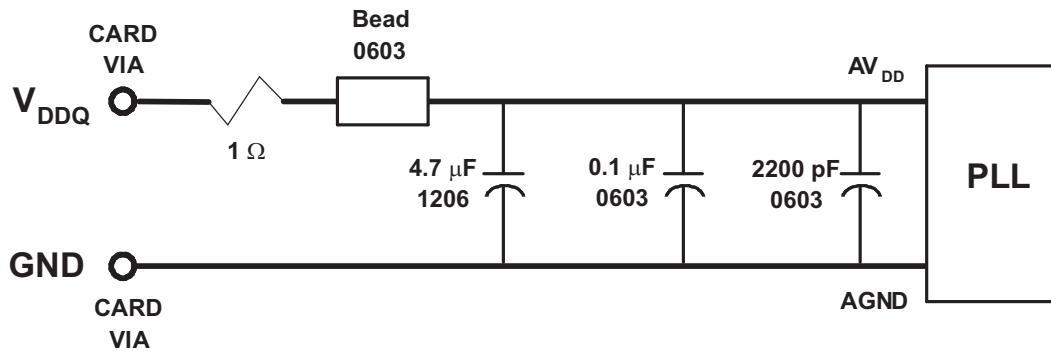

Figure 11. Time Delay Between OE and Clock Output (Y, \bar{Y})

RECOMMENDED AV_{DD} FILTERING



- Place the 2200-pF capacitor close to the PLL.
- Use a wide trace for the PLL analog power and ground. Connect PLL and capacitors to AGND trace and connect trace to one GND via (farthest from the PLL).
- Recommended bead: Fair-Rite PN 2506036017Y0 or equivalent (0.8 Ω dc maximum, 600 Ω at 100 MHz).

Figure 12. Recommended AV_{DD} Filtering

PACKAGING INFORMATION

Orderable Device	Status ⁽¹⁾	Package Type	Package Drawing	Pins	Package Qty	Eco Plan ⁽²⁾	Lead/Ball Finish	MSL Peak Temp ⁽³⁾
CDCU877AGQLR	ACTIVE	BGA MI CROSTA R JUNI OR	GQL	52	1000	TBD	SNPB	Level-2-235C-1 YEAR
CDCU877AGQLT	ACTIVE	BGA MI CROSTA R JUNI OR	GQL	52	250	TBD	SNPB	Level-2-235C-1 YEAR
CDCU877ARHAR	ACTIVE	QFN	RHA	40	2500	Green (RoHS & no Sb/Br)	CU NIPDAU	Level-3-260C-168 HR
CDCU877ARHARG4	ACTIVE	QFN	RHA	40	2500	Green (RoHS & no Sb/Br)	CU NIPDAU	Level-3-260C-168 HR
CDCU877ARHAT	ACTIVE	QFN	RHA	40	250	Green (RoHS & no Sb/Br)	CU NIPDAU	Level-3-260C-168 HR
CDCU877ARHATG4	ACTIVE	QFN	RHA	40	250	Green (RoHS & no Sb/Br)	CU NIPDAU	Level-3-260C-168 HR
CDCU877ARTBR	ACTIVE	QFN	RTB	40	2500	TBD	CU SNPB	Level-3-235C-168 HR
CDCU877ARTBT	ACTIVE	QFN	RTB	40	250	TBD	CU SNPB	Level-3-235C-168 HR
CDCU877AZQLR	ACTIVE	BGA MI CROSTA R JUNI OR	ZQL	52	1000	Green (RoHS & no Sb/Br)	SNAGCU	Level-2-260C-1 YEAR
CDCU877AZQLT	ACTIVE	BGA MI CROSTA R JUNI OR	ZQL	52	250	Green (RoHS & no Sb/Br)	SNAGCU	Level-2-260C-1 YEAR
CDCU877GQLR	ACTIVE	BGA MI CROSTA R JUNI OR	GQL	52	1000	TBD	SNPB	Level-2-235C-1 YEAR
CDCU877GQLT	ACTIVE	BGA MI CROSTA R JUNI OR	GQL	52	250	TBD	SNPB	Level-2-235C-1 YEAR
CDCU877RHAR	ACTIVE	QFN	RHA	40	2500	Green (RoHS & no Sb/Br)	CU NIPDAU	Level-3-260C-168 HR
CDCU877RHARG4	ACTIVE	QFN	RHA	40	2500	Green (RoHS & no Sb/Br)	CU NIPDAU	Level-3-260C-168 HR
CDCU877RHAT	ACTIVE	QFN	RHA	40	250	Green (RoHS & no Sb/Br)	CU NIPDAU	Level-3-260C-168 HR
CDCU877RHATG4	ACTIVE	QFN	RHA	40	250	Green (RoHS & no Sb/Br)	CU NIPDAU	Level-3-260C-168 HR
CDCU877RTBR	ACTIVE	QFN	RTB	40	2500	TBD	CU SNPB	Level-3-235C-168 HR
CDCU877RTBT	ACTIVE	QFN	RTB	40	250	TBD	CU SNPB	Level-3-235C-168 HR
CDCU877ZQLR	ACTIVE	BGA MI CROSTA R JUNI OR	ZQL	52	1000	Green (RoHS & no Sb/Br)	SNAGCU	Level-2-260C-1 YEAR
CDCU877ZQLT	ACTIVE	BGA MI CROSTA R JUNI OR	ZQL	52	250	Green (RoHS & no Sb/Br)	SNAGCU	Level-2-260C-1 YEAR

Orderable Device	Status ⁽¹⁾	Package Type	Package Drawing	Pins	Package Qty	Eco Plan ⁽²⁾	Lead/Ball Finish	MSL Peak Temp ⁽³⁾
OR								

⁽¹⁾ The marketing status values are defined as follows:

ACTIVE: Product device recommended for new designs.

LIFEBUY: TI has announced that the device will be discontinued, and a lifetime-buy period is in effect.

NRND: Not recommended for new designs. Device is in production to support existing customers, but TI does not recommend using this part in a new design.

PREVIEW: Device has been announced but is not in production. Samples may or may not be available.

OBSOLETE: TI has discontinued the production of the device.

⁽²⁾ Eco Plan - The planned eco-friendly classification: Pb-Free (RoHS), Pb-Free (RoHS Exempt), or Green (RoHS & no Sb/Br) - please check <http://www.ti.com/productcontent> for the latest availability information and additional product content details.

TBD: The Pb-Free/Green conversion plan has not been defined.

Pb-Free (RoHS): TI's terms "Lead-Free" or "Pb-Free" mean semiconductor products that are compatible with the current RoHS requirements for all 6 substances, including the requirement that lead not exceed 0.1% by weight in homogeneous materials. Where designed to be soldered at high temperatures, TI Pb-Free products are suitable for use in specified lead-free processes.

Pb-Free (RoHS Exempt): This component has a RoHS exemption for either 1) lead-based flip-chip solder bumps used between the die and package, or 2) lead-based die adhesive used between the die and leadframe. The component is otherwise considered Pb-Free (RoHS compatible) as defined above.

Green (RoHS & no Sb/Br): TI defines "Green" to mean Pb-Free (RoHS compatible), and free of Bromine (Br) and Antimony (Sb) based flame retardants (Br or Sb do not exceed 0.1% by weight in homogeneous material)

⁽³⁾ MSL, Peak Temp. -- The Moisture Sensitivity Level rating according to the JEDEC industry standard classifications, and peak solder temperature.

Important Information and Disclaimer:The information provided on this page represents TI's knowledge and belief as of the date that it is provided. TI bases its knowledge and belief on information provided by third parties, and makes no representation or warranty as to the accuracy of such information. Efforts are underway to better integrate information from third parties. TI has taken and continues to take reasonable steps to provide representative and accurate information but may not have conducted destructive testing or chemical analysis on incoming materials and chemicals. TI and TI suppliers consider certain information to be proprietary, and thus CAS numbers and other limited information may not be available for release.

In no event shall TI's liability arising out of such information exceed the total purchase price of the TI part(s) at issue in this document sold by TI to Customer on an annual basis.

TAPE AND REEL INFORMATION

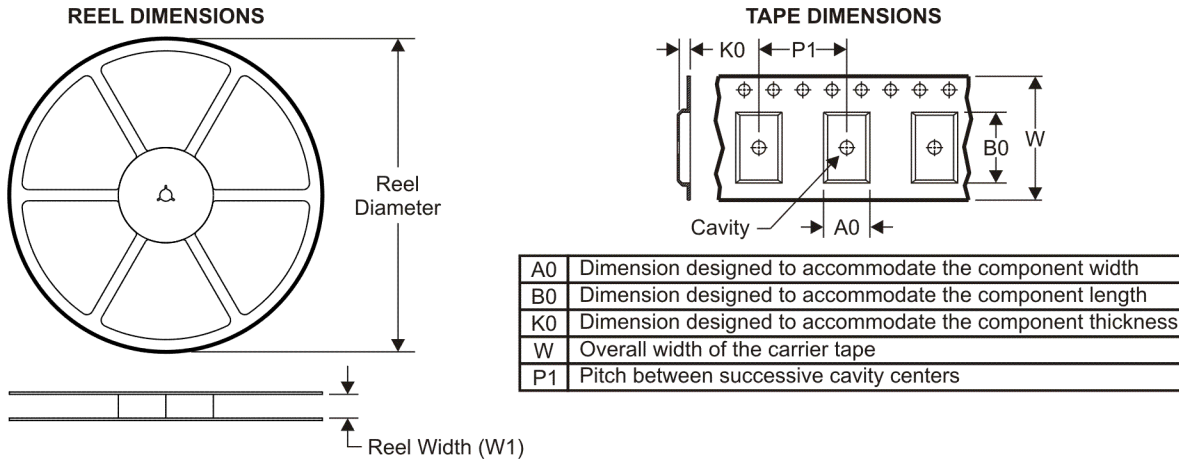

QUADRANT ASSIGNMENTS FOR PIN 1 ORIENTATION IN TAPE



*All dimensions are nominal

Device	Package Type	Package Drawing	Pins	SPQ	Reel Diameter (mm)	Reel Width W1 (mm)	A0 (mm)	B0 (mm)	K0 (mm)	P1 (mm)	W (mm)	Pin1 Quadrant
CDCU877AGQLR	BGA MICROSTAR JUNIOR	GQL	52	1000	330.0	16.4	4.8	7.3	1.5	8.0	16.0	Q1
CDCU877AGQLT	BGA MICROSTAR JUNIOR	GQL	52	250	330.0	16.4	4.8	7.3	1.5	8.0	16.0	Q1
CDCU877ARHAR	QFN	RHA	40	2500	330.0	16.4	6.3	6.3	1.5	12.0	16.0	Q2
CDCU877ARHAT	QFN	RHA	40	250	330.0	16.4	6.3	6.3	1.5	12.0	16.0	Q2
CDCU877ARTBR	QFN	RTB	40	2500	330.0	16.4	6.3	6.3	1.5	12.0	16.0	Q2
CDCU877ARTBT	QFN	RTB	40	250	330.0	16.4	6.3	6.3	1.5	12.0	16.0	Q2
CDCU877AZQLR	BGA MICROSTAR JUNIOR	ZQL	52	1000	330.0	16.4	4.8	7.3	1.5	8.0	16.0	Q1
CDCU877AZQLT	BGA MICROSTAR JUNIOR	ZQL	52	250	330.0	16.4	4.8	7.3	1.5	8.0	16.0	Q1
CDCU877GQLR	BGA MICROSTAR	GQL	52	1000	330.0	16.4	4.8	7.3	1.5	8.0	16.0	Q1

Device	Package Type	Package Drawing	Pins	SPQ	Reel Diameter (mm)	Reel Width W1 (mm)	A0 (mm)	B0 (mm)	K0 (mm)	P1 (mm)	W (mm)	Pin1 Quadrant
	R JUNIOR											
CDCU877GQLT	BGA MICROSTAR JUNIOR	GQL	52	250	330.0	16.4	4.8	7.3	1.5	8.0	16.0	Q1
CDCU877RHAR	QFN	RHA	40	2500	330.0	16.4	6.3	6.3	1.5	12.0	16.0	Q2
CDCU877RHAT	QFN	RHA	40	250	330.0	16.4	6.3	6.3	1.5	12.0	16.0	Q2
CDCU877RTBR	QFN	RTB	40	2500	330.0	16.4	6.3	6.3	1.5	12.0	16.0	Q2
CDCU877RTBT	QFN	RTB	40	250	330.0	16.4	6.3	6.3	1.5	12.0	16.0	Q2
CDCU877ZQLR	BGA MICROSTAR JUNIOR	ZQL	52	1000	330.0	16.4	4.8	7.3	1.5	8.0	16.0	Q1
CDCU877ZQLT	BGA MICROSTAR JUNIOR	ZQL	52	250	330.0	16.4	4.8	7.3	1.5	8.0	16.0	Q1

TAPE AND REEL BOX DIMENSIONS

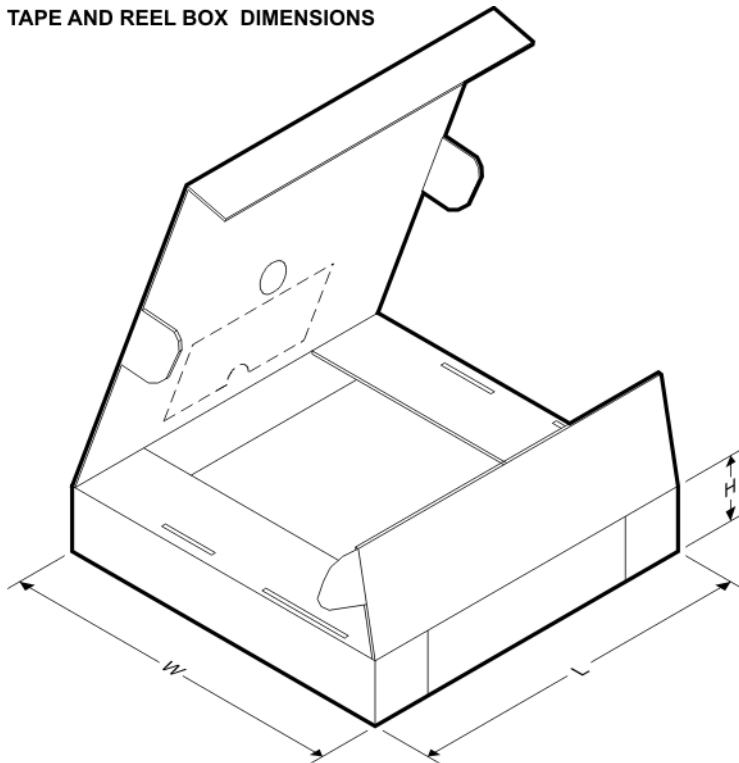

*All dimensions are nominal



Device	Package Type	Package Drawing	Pins	SPQ	Length (mm)	Width (mm)	Height (mm)
CDCU877AGQLR	BGA MICROSTAR JUNIOR	GQL	52	1000	333.2	345.9	28.6

Device	Package Type	Package Drawing	Pins	SPQ	Length (mm)	Width (mm)	Height (mm)
CDCU877AGQLT	BGA MICROSTAR JUNIOR	GQL	52	250	333.2	345.9	28.6
CDCU877ARHAR	QFN	RHA	40	2500	333.2	345.9	28.6
CDCU877ARHAT	QFN	RHA	40	250	333.2	345.9	28.6
CDCU877ARTBR	QFN	RTB	40	2500	333.2	345.9	28.6
CDCU877ARTBT	QFN	RTB	40	250	333.2	345.9	28.6
CDCU877AZQLR	BGA MICROSTAR JUNIOR	ZQL	52	1000	333.2	345.9	28.6
CDCU877AZQLT	BGA MICROSTAR JUNIOR	ZQL	52	250	333.2	345.9	28.6
CDCU877GQLR	BGA MICROSTAR JUNIOR	GQL	52	1000	333.2	345.9	28.6
CDCU877GQLT	BGA MICROSTAR JUNIOR	GQL	52	250	333.2	345.9	28.6
CDCU877RHAR	QFN	RHA	40	2500	333.2	345.9	28.6
CDCU877RHAT	QFN	RHA	40	250	333.2	345.9	28.6
CDCU877RTBR	QFN	RTB	40	2500	333.2	345.9	28.6
CDCU877RTBT	QFN	RTB	40	250	333.2	345.9	28.6
CDCU877ZQLR	BGA MICROSTAR JUNIOR	ZQL	52	1000	333.2	345.9	28.6
CDCU877ZQLT	BGA MICROSTAR JUNIOR	ZQL	52	250	333.2	345.9	28.6

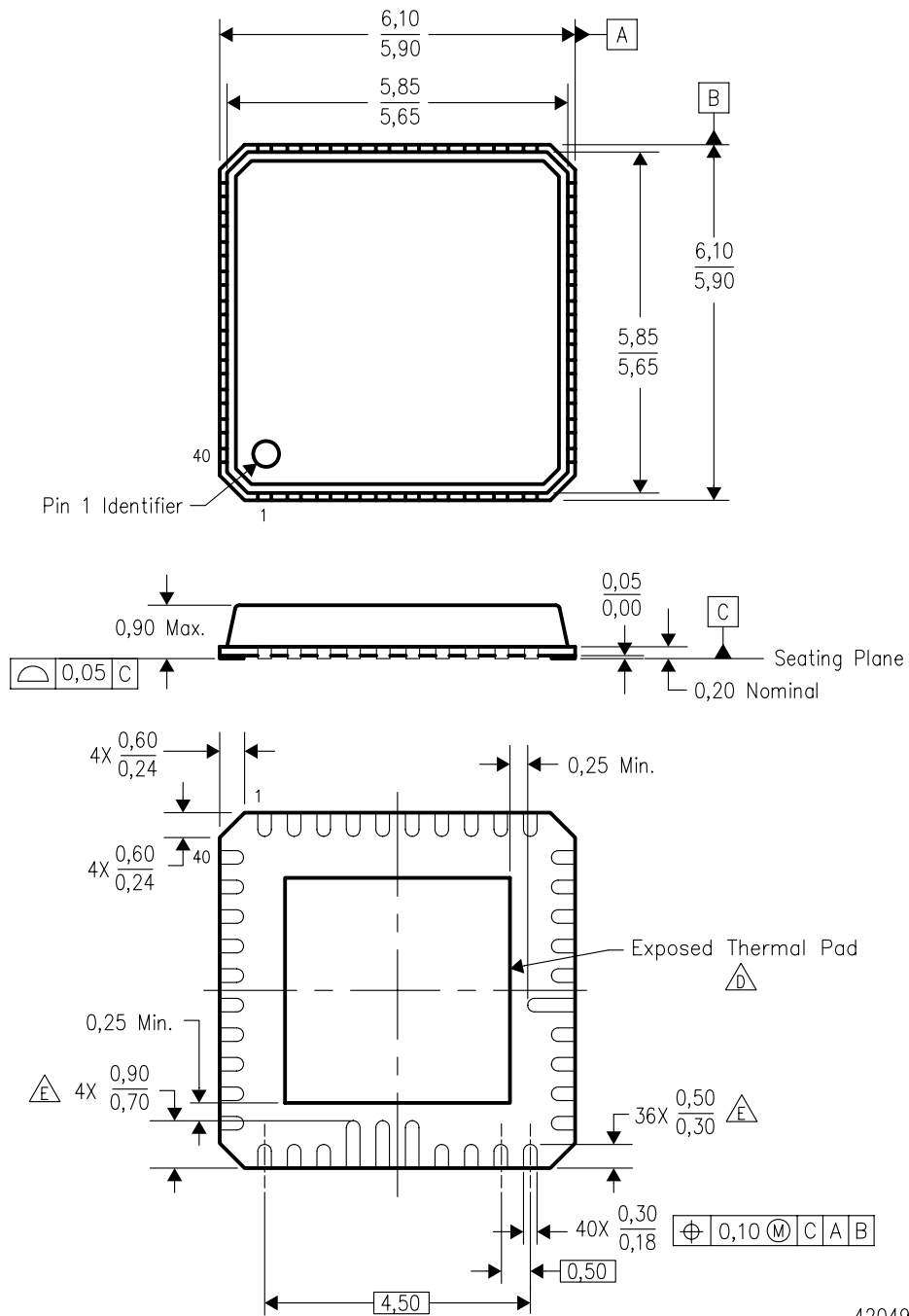
RTB (S-PQFP-N40) *LONG LEAD OPTION* PLASTIC QUAD FLATPACK



4204967-3/E 05/07

- NOTES: A. All linear dimensions are in millimeters.  The package thermal pad must be soldered to the board for thermal and mechanical performance. See the Product Data Sheet for details regarding the exposed thermal pad dimensions.
- B. This drawing is subject to change without notice.
- C. QFN (Quad Flatpack No-Lead) Package configuration.  Selected lands extended past 0,50 length.

THERMAL INFORMATION

This package incorporates an exposed thermal pad that is designed to be attached directly to an external heatsink. The thermal pad must be soldered directly to the printed circuit board (PCB). After soldering, the PCB can be used as a heatsink. In addition, through the use of thermal vias, the thermal pad can be attached directly to the appropriate copper plane shown in the electrical schematic for the device, or alternatively, can be attached to a special heatsink structure designed into the PCB. This design optimizes the heat transfer from the integrated circuit (IC).

For information on the Quad Flatpack No-Lead (QFN) package and its advantages, refer to Application Report, Quad Flatpack No-Lead Logic Packages, Texas Instruments Literature No. SCBA017. This document is available at www.ti.com.

The exposed thermal pad dimensions for this package are shown in the following illustration.

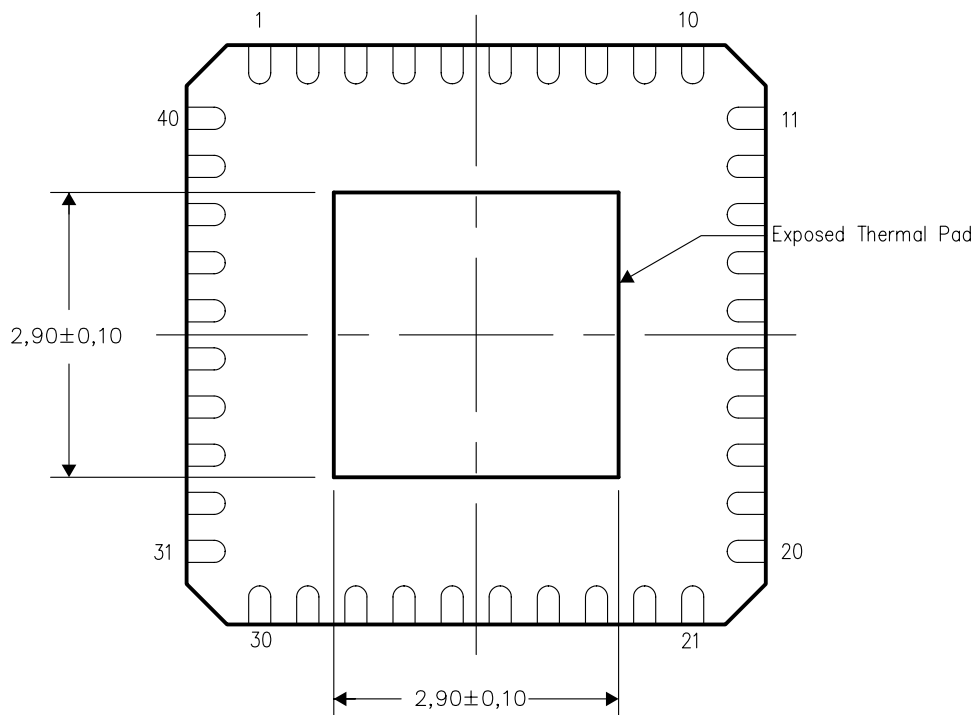

Bottom View

NOTE: All linear dimensions are in millimeters

Exposed Thermal Pad Dimensions

THERMAL INFORMATION

This package incorporates an exposed thermal pad that is designed to be attached directly to an external heatsink. The thermal pad must be soldered directly to the printed circuit board (PCB). After soldering, the PCB can be used as a heatsink. In addition, through the use of thermal vias, the thermal pad can be attached directly to the appropriate copper plane shown in the electrical schematic for the device, or alternatively, can be attached to a special heatsink structure designed into the PCB. This design optimizes the heat transfer from the integrated circuit (IC).

For information on the Quad Flatpack No-Lead (QFN) package and its advantages, refer to Application Report, Quad Flatpack No-Lead Logic Packages, Texas Instruments Literature No. SCBA017. This document is available at www.ti.com.

The exposed thermal pad dimensions for this package are shown in the following illustration.

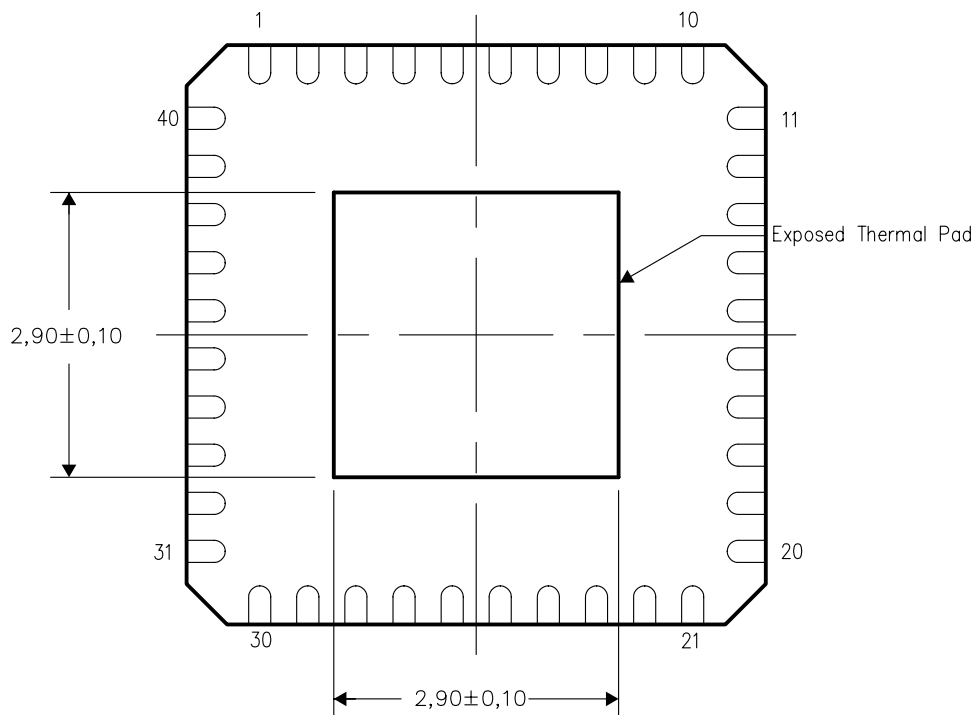

Bottom View

NOTE: All linear dimensions are in millimeters

Exposed Thermal Pad Dimensions

ZQL (R-PBGA-N52)

PLASTIC BALL GRID ARRAY

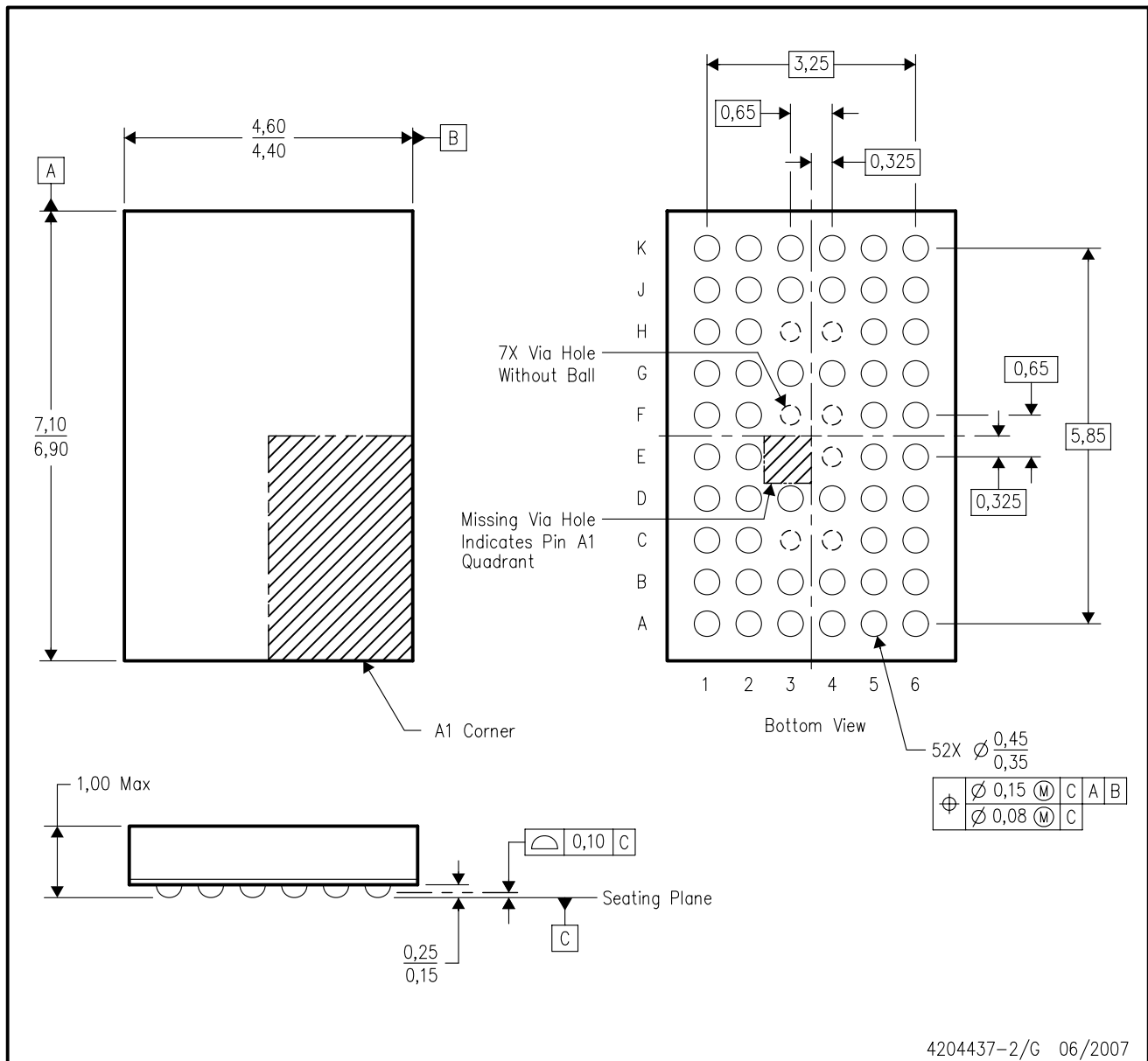

- NOTES:
- A. All linear dimensions are in millimeters. Dimensioning and tolerancing per ASME Y14.5M-1994.
 - B. This drawing is subject to change without notice.
 - C. Falls within JEDEC MO-285 variation BA-2.
 - D. This package is lead-free. Refer to the 52 GQL package (drawing 4200583) for tin-lead (SnPb).

RHA (S-PQFP-N40)

PLASTIC QUAD FLATPACK

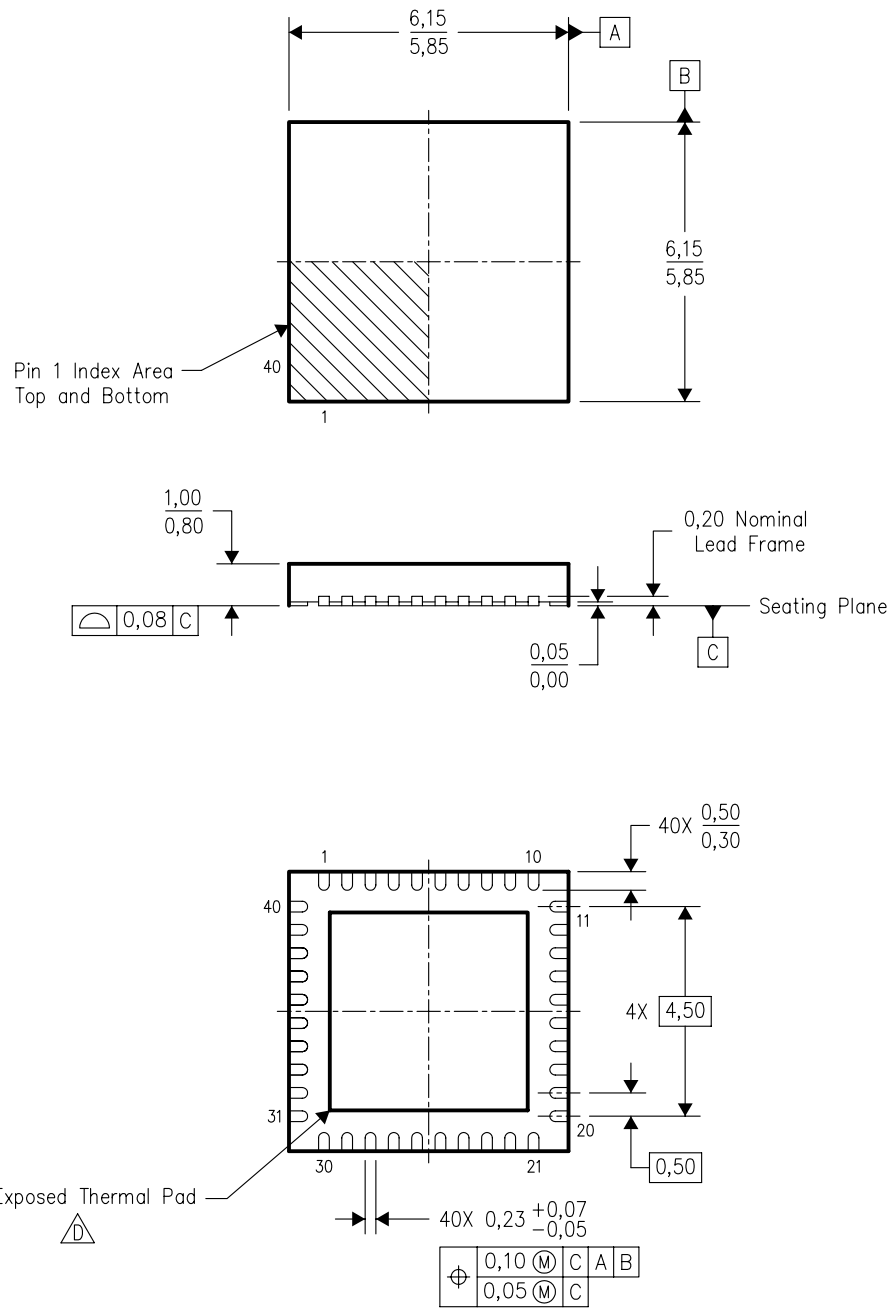

Bottom View

4204276/C 12/2004

- NOTES:
- A. All linear dimensions are in millimeters. Dimensioning and tolerancing per ASME Y14.5M-1994.
 - B. This drawing is subject to change without notice.
 - C. QFN (Quad Flatpack No-Lead) Package configuration.
 -  D. The package thermal pad must be soldered to the board for thermal and mechanical performance. See the Product Data Sheet for details regarding the exposed thermal pad dimensions.
 - E. Package complies to JEDEC MO-220 variation VJJD-2.

THERMAL INFORMATION

This package incorporates an exposed thermal pad that is designed to be attached directly to an external heatsink. The thermal pad must be soldered directly to the printed circuit board (PCB). After soldering, the PCB can be used as a heatsink. In addition, through the use of thermal vias, the thermal pad can be attached directly to the appropriate copper plane shown in the electrical schematic for the device, or alternatively, can be attached to a special heatsink structure designed into the PCB. This design optimizes the heat transfer from the integrated circuit (IC).

For information on the Quad Flatpack No-Lead (QFN) package and its advantages, refer to Application Report, Quad Flatpack No-Lead Logic Packages, Texas Instruments Literature No. SCBA017. This document is available at www.ti.com.

The exposed thermal pad dimensions for this package are shown in the following illustration.

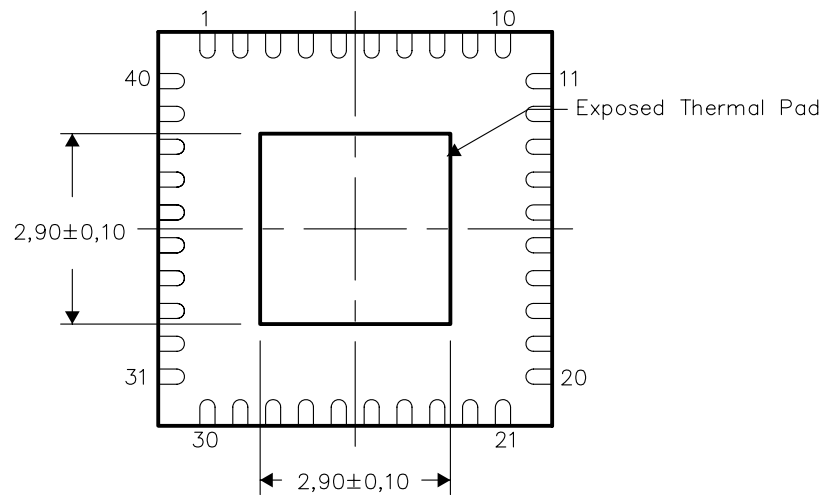

Bottom View

NOTE: All linear dimensions are in millimeters

Exposed Thermal Pad Dimensions

RHA (S-PQFP-N40)

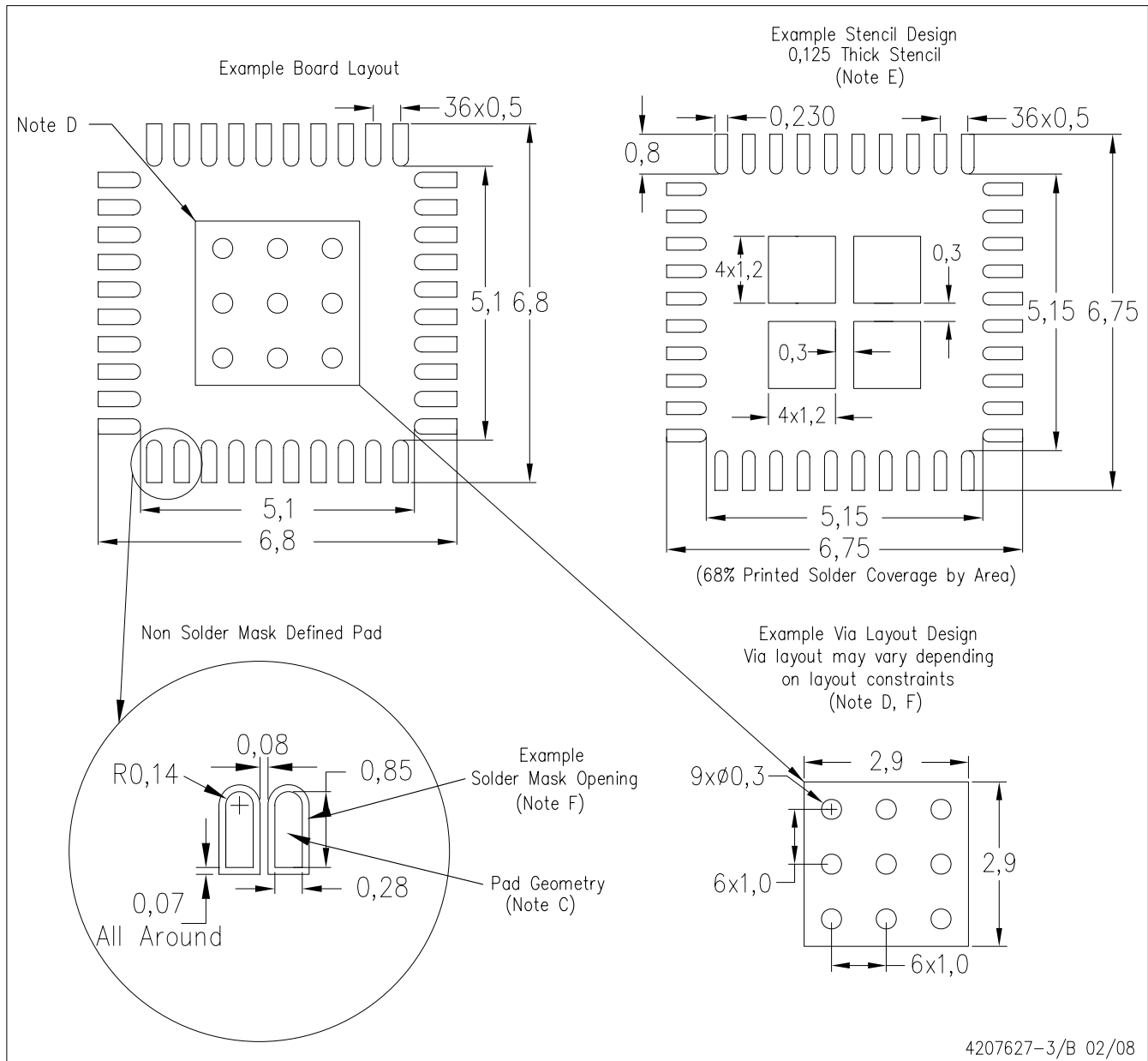

- NOTES:
- A. All linear dimensions are in millimeters.
 - B. This drawing is subject to change without notice.
 - C. Publication IPC-7351 is recommended for alternate designs.
 - D. This package is designed to be soldered to a thermal pad on the board. Refer to Application Note, Quad Flat-Pack Packages, Texas Instruments Literature No. SCBA017, SLUA271, and also the Product Data Sheets for specific thermal information, via requirements, and recommended board layout. These documents are available at www.ti.com <<http://www.ti.com>>.
 - E. Laser cutting apertures with trapezoidal walls and also rounding corners will offer better paste release. Customers should contact their board assembly site for stencil design recommendations. Refer to IPC 7525 for stencil design considerations.
 - F. Customers should contact their board fabrication site for recommended solder mask tolerances and via tenting recommendations for vias placed in the thermal pad.

GQL (R-PBGA-N52)

PLASTIC BALL GRID ARRAY

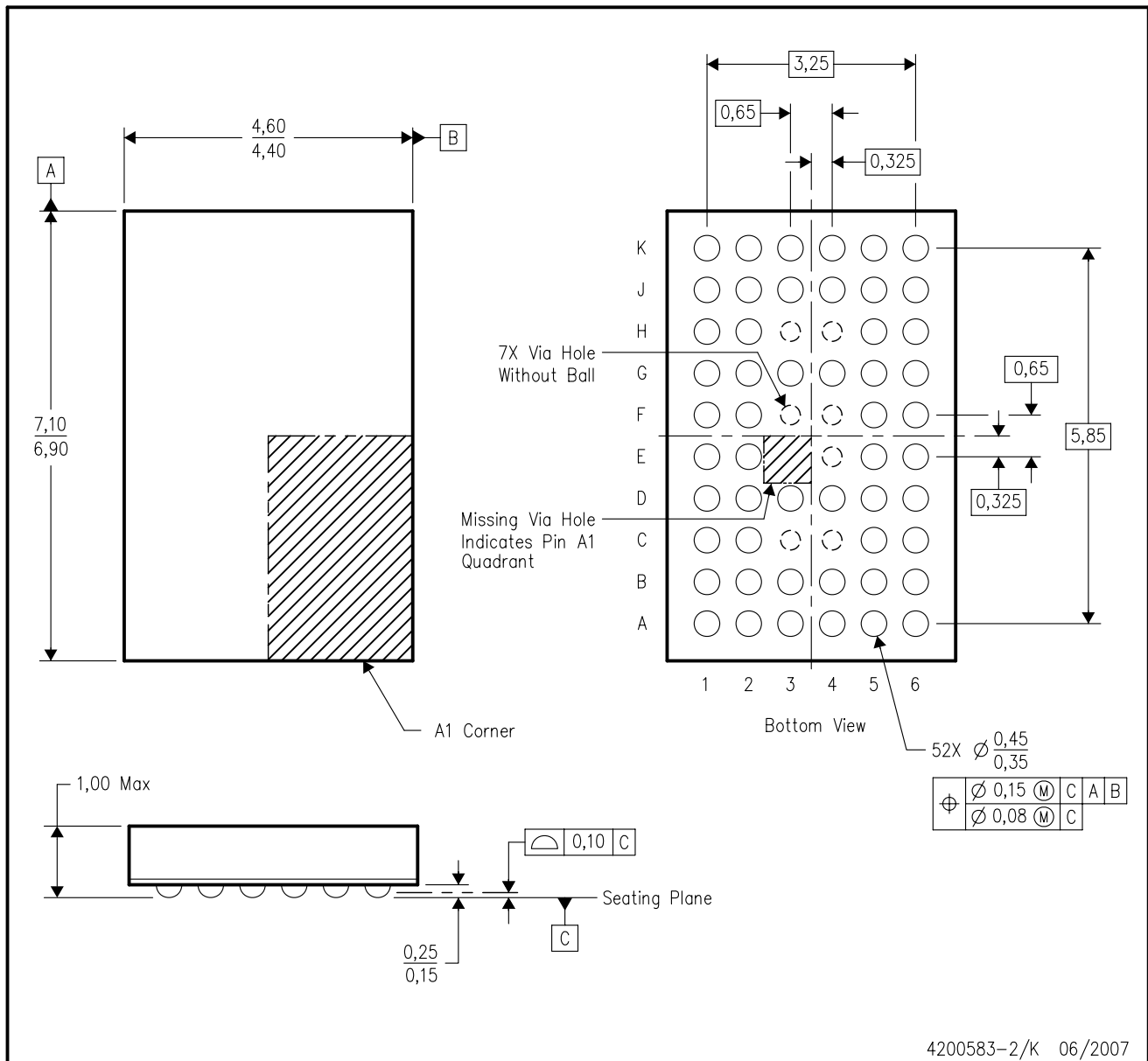

- NOTES:
- A. All linear dimensions are in millimeters. Dimensioning and tolerancing per ASME Y14.5M-1994.
 - B. This drawing is subject to change without notice.
 - C. Falls within JEDEC M0-285 variation BA-2.
 - D. This package is tin-lead (SnPb). Refer to the 52 ZQL package (drawing 4204437) for lead-free.

IMPORTANT NOTICE

Texas Instruments Incorporated and its subsidiaries (TI) reserve the right to make corrections, modifications, enhancements, improvements, and other changes to its products and services at any time and to discontinue any product or service without notice. Customers should obtain the latest relevant information before placing orders and should verify that such information is current and complete. All products are sold subject to TI's terms and conditions of sale supplied at the time of order acknowledgment.

TI warrants performance of its hardware products to the specifications applicable at the time of sale in accordance with TI's standard warranty. Testing and other quality control techniques are used to the extent TI deems necessary to support this warranty. Except where mandated by government requirements, testing of all parameters of each product is not necessarily performed.

TI assumes no liability for applications assistance or customer product design. Customers are responsible for their products and applications using TI components. To minimize the risks associated with customer products and applications, customers should provide adequate design and operating safeguards.

TI does not warrant or represent that any license, either express or implied, is granted under any TI patent right, copyright, mask work right, or other TI intellectual property right relating to any combination, machine, or process in which TI products or services are used. Information published by TI regarding third-party products or services does not constitute a license from TI to use such products or services or a warranty or endorsement thereof. Use of such information may require a license from a third party under the patents or other intellectual property of the third party, or a license from TI under the patents or other intellectual property of TI.

Reproduction of TI information in TI data books or data sheets is permissible only if reproduction is without alteration and is accompanied by all associated warranties, conditions, limitations, and notices. Reproduction of this information with alteration is an unfair and deceptive business practice. TI is not responsible or liable for such altered documentation. Information of third parties may be subject to additional restrictions.

Resale of TI products or services with statements different from or beyond the parameters stated by TI for that product or service voids all express and any implied warranties for the associated TI product or service and is an unfair and deceptive business practice. TI is not responsible or liable for any such statements.

TI products are not authorized for use in safety-critical applications (such as life support) where a failure of the TI product would reasonably be expected to cause severe personal injury or death, unless officers of the parties have executed an agreement specifically governing such use. Buyers represent that they have all necessary expertise in the safety and regulatory ramifications of their applications, and acknowledge and agree that they are solely responsible for all legal, regulatory and safety-related requirements concerning their products and any use of TI products in such safety-critical applications, notwithstanding any applications-related information or support that may be provided by TI. Further, Buyers must fully indemnify TI and its representatives against any damages arising out of the use of TI products in such safety-critical applications.

TI products are neither designed nor intended for use in military/aerospace applications or environments unless the TI products are specifically designated by TI as military-grade or "enhanced plastic." Only products designated by TI as military-grade meet military specifications. Buyers acknowledge and agree that any such use of TI products which TI has not designated as military-grade is solely at the Buyer's risk, and that they are solely responsible for compliance with all legal and regulatory requirements in connection with such use.

TI products are neither designed nor intended for use in automotive applications or environments unless the specific TI products are designated by TI as compliant with ISO/TS 16949 requirements. Buyers acknowledge and agree that, if they use any non-designated products in automotive applications, TI will not be responsible for any failure to meet such requirements.

Following are URLs where you can obtain information on other Texas Instruments products and application solutions:

Products

Amplifiers	amplifier.ti.com
Data Converters	dataconverter.ti.com
DSP	dsp.ti.com
Clocks and Timers	www.ti.com/clocks
Interface	interface.ti.com
Logic	logic.ti.com
Power Mgmt	power.ti.com
Microcontrollers	microcontroller.ti.com
RFID	www.ti-rfid.com
RF/IF and ZigBee® Solutions	www.ti.com/lprf

Applications

Audio	www.ti.com/audio
Automotive	www.ti.com/automotive
Broadband	www.ti.com/broadband
Digital Control	www.ti.com/digitalcontrol
Medical	www.ti.com/medical
Military	www.ti.com/military
Optical Networking	www.ti.com/opticalnetwork
Security	www.ti.com/security
Telephony	www.ti.com/telephony
Video & Imaging	www.ti.com/video
Wireless	www.ti.com/wireless

Mailing Address: Texas Instruments, Post Office Box 655303, Dallas, Texas 75265
Copyright © 2008, Texas Instruments Incorporated