

Distributed by:

JAMECO[®]
ELECTRONICS

www.Jameco.com ♦ 1-800-831-4242

The content and copyrights of the attached
material are the property of its owner.

Jameco Part Number 1525837

LOW-VOLTAGE 1:10 LVPECL/HSTL WITH SELECTABLE INPUT CLOCK DRIVER

FEATURES

- Distributes One Differential Clock Input Pair LVPECL/HSTL to 10 Differential LVPECL Clock Outputs
- Fully Compatible With LVECL/LVPECL/HSTL
- Single Supply Voltage Required, $\pm 3.3\text{-V}$ or $\pm 2.5\text{-V}$ Supply
- Selectable Clock Input Through CLK_SEL
- Low-Output Skew (Typ 15 ps) for Clock-Distribution Applications
- VBB Reference Voltage Output for Single-Ended Clocking
- Available in a 32-Pin LQFP Package
- Frequency Range From DC to 3.5 GHz
- Pin-to-Pin Compatible With MC100 Series EP111, ES6111, LVEP111, PTN1111

DESCRIPTION

The CDCLVP110 clock driver distributes one differential clock pair of either LVPECL or HSTL (selectable) input, (CLK0, CLK1) to ten pairs of differential LVPECL clock (Q0, Q9) outputs with minimum skew for clock distribution. The CDCLVP110 can accept two clock sources into an input multiplexer. The CLK0 input accepts either LVECL/LVPECL input signals, while CLK1 accepts an HSTL input signal when operated under LVPECL conditions. The CDCLVP110 is specifically designed for driving 50- Ω transmission lines.

The VBB reference voltage output is used if single-ended input operation is required. In this case the VBB pin should be connected to $\overline{\text{CLK0}}$ and bypassed to GND via a 10-nF capacitor.

However, for high-speed performance up to 3.5 GHz, the differential mode is strongly recommended.

The CDCLVP110 is characterized for operation from -40°C to 85°C .

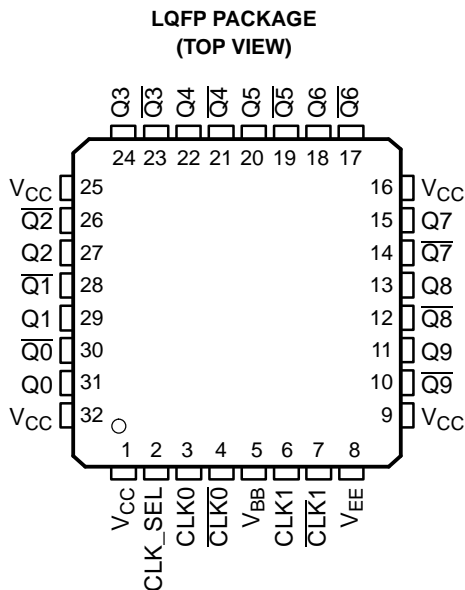

FUNCTION TABLE

CLK_SEL	ACTIVE CLOCK INPUT
0	CLK0, $\overline{\text{CLK0}}$
1	CLK1, $\overline{\text{CLK1}}$



Please be aware that an important notice concerning availability, standard warranty, and use in critical applications of Texas Instruments semiconductor products and disclaimers thereto appears at the end of this data sheet.

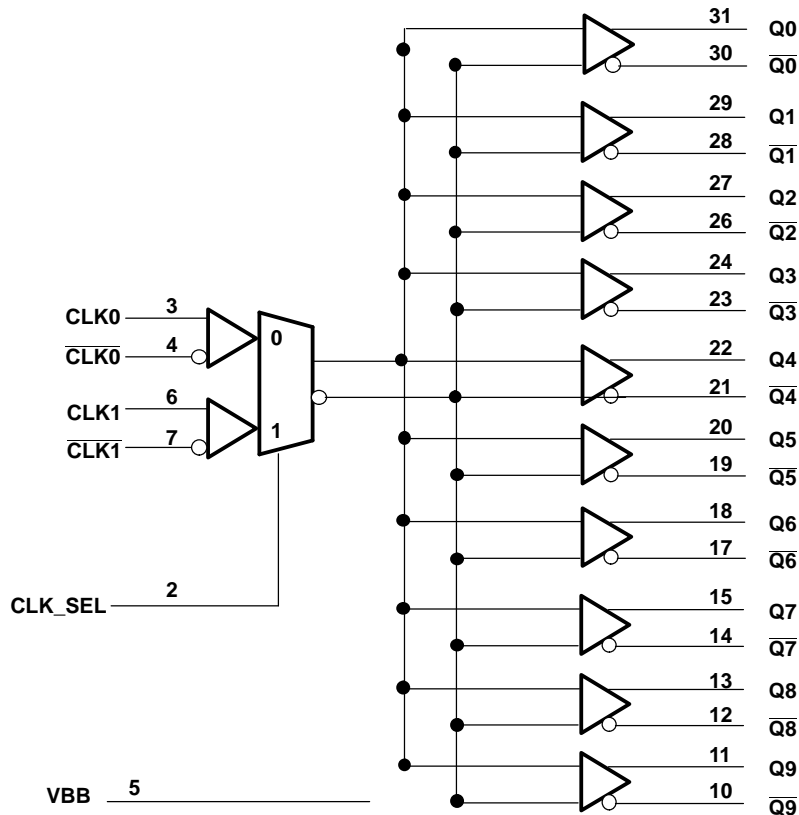

TERMINAL FUNCTIONS

TERMINAL		DESCRIPTION
NAME	NO.	
CLK_SEL	2	Clock select. Used to select between CLK0 and CLK1 input pairs.
CLK0, $\overline{\text{CLK0}}$	3, 4	Differential LVECL/LVPECL input pair
CLK1, $\overline{\text{CLK1}}$	6, 7	Differential HSTL input pair
Q [9:0]	11, 13, 15, 18, 20, 22, 24, 27, 29, 31	LVECL/LVPECL clock outputs, these outputs provide low-skew copies of CLKn.
$\overline{\text{Q}}[9:0]$	10, 12, 14, 17, 19, 21, 23, 26, 28, 30	LVECL/LVPECL complementary clock outputs, these outputs provide copies of $\overline{\text{CLKn}}$.
V _{BB}	5	Reference voltage output for single-ended input operation
V _{CC}	1, 9, 16, 25, 32	Supply voltage
V _{EE}	8	Device ground or negative supply voltage in ECL mode

ABSOLUTE MAXIMUM RATINGS⁽¹⁾

V_{CC}	Supply voltage	-0.3 V to 4.6 V
V_I	Input voltage	-0.3 V to $V_{CC} + 0.5$ V
V_O	Output voltage	-0.3 V to $V_{CC} + 0.5$ V
I_{IN}	Input current	±20 mA
V_{EE}	Negative supply voltage	-0.3 V to 4.6 V
I_{BB}	Sink/source current	-1 to 1 mA
I_O	DC output current	-50 mA
T_{stg}	Storage temperature range	-65°C to 150°C

(1) Stresses beyond those listed under "absolute maximum ratings" may cause permanent damage to the device. These are stress ratings only, and functional operation of the device at these or any other conditions beyond those indicated under "recommended operating conditions" is not implied. Exposure to absolute-maximum-rated conditions for extended periods may affect device reliability.

RECOMMENDED OPERATING CONDITIONS

		MIN	NOM	MAX	UNIT
V_{CC}	Supply voltage (relative to V_{EE})	2.375	2.5/3.3	3.8	V
$T_A^{(1)}$	Operating free-air temperature	-40		85	°C

(1) Operating junction temperature affects device lifetime. The continuous operation junction temperature is recommended to be at max 110°C. The device ac and dc parameters are specified up to 85°C ambient temperature. See the *PCB Layout Guidelines for CDCLVP110* application note, literature number SCAA057 for more details.

PACKAGE THERMAL IMPEDANCE

		TEST CONDITION	MIN	MAX	UNIT
Θ_{JA}	Thermal resistance junction to ambient ⁽¹⁾	0 LFM		78	°C/W
		150 LFM		73	°C/W
		250 LFM		71	°C/W
		500 LFM		68	°C/W
Θ_{JC}	Thermal resistance junction to case			51	°C/W

(1) According to JESD 51-7 standard.

LVECL DC ELECTRICAL CHARACTERISTICS

V_{supply} : $V_{CC} = 0$ V, $V_{EE} = -2.375$ V to -3.8 V

PARAMETER	TEST CONDITIONS	MIN	TYP	MAX	UNIT
I_{EE}	Supply internal current Absolute value of current	-40°C	40	78	mA
		25°C	45	82	
		85°C	48	85	
I_{CC}	Output and internal supply current All outputs terminated 50 Ω to $V_{CC} - 2$ V	-40°C		343	mA
		25°C		370	
		85°C		380	
I_{IN}	Input current Includes pullup/pulldown resistors	-40°C, 25°C, 85°C		150	μ A
V_{BB}	Internally generated bias voltage For $V_{EE} = -3$ to -3.8 V, $I_{BB} = -0.2$ mA	-40°C	-1.38	-1.26	V
		25°C	-1.42	-1.26	
	85°C	-1.45	-1.26		
	$V_{EE} = -2.375$ to -2.75 V, $I_{BB} = -0.2$ mA	-40°C, 25°C, 85°C	-1.38	-1.16	
V_{IH}	High-level input voltage (CLK_SEL)	-40°C, 25°C, 85°C	-1.165	-0.88	V

LVECL DC ELECTRICAL CHARACTERISTICS (continued)Vsupply: $V_{CC} = 0\text{ V}$, $V_{EE} = -2.375\text{ V}$ to -3.8 V

PARAMETER		TEST CONDITIONS	MIN	TYP	MAX	UNIT
V_{IL}	Low-level input voltage (CLK_SEL)		-40°C, 25°C, 85°C	-1.81	-1.475	V
V_{INPP}	Input amplitude (CLK0, $\overline{\text{CLK0}}$)	Difference of input 9 $V_{IH}-V_{IL}$, See Note (1)	-40°C, 25°C, 85°C	0.5	1.3	V
V_{CM}	Common-mode voltage (CLK0, $\overline{\text{CLK0}}$)	Cross point of input 9 average (V_{IH} , V_{IL})	-40°C, 25°C, 85°C	$V_{EE} + 1$	-0.3	V
V_{OH}	High-level output voltage	$I_{OH} = -21\text{ mA}$	-40°C	-1.26	-0.9	V
			25°C	-1.2	-0.9	
			85°C	-1.15	-0.9	
V_{OL}	Low-level output voltage	$I_{OL} = -5\text{ mA}$	-40°C	-1.85	-1.5	V
			25°C	-1.85	-1.45	
			85°C	-1.85	-1.4	
V_{OD}	Differential output voltage swing	Terminated with 50 Ω to $V_{CC} - 2\text{ V}$, See Figure 3	-40°C, 25°C, 85°C	600		V

(1) V_{INPP} minimum and maximum is required to maintain ac specifications, actual device function tolerates a minimum V_{INPP} of 100 mV.**LVPECL/HSTL DC ELECTRICAL CHARACTERISTICS**Vsupply: $V_{CC} = 2.375\text{ V}$ to 3.8 V , $V_{EE} = 0\text{ V}$

PARAMETER		TEST CONDITIONS	MIN	TYP	MAX	UNIT
I_{EE}	Supply internal current	Absolute value of current	-40°C	40	78	mA
			25°C	45	82	
			85°C	48	85	
I_{CC}	Output and internal supply current	All outputs terminated 50 Ω to $V_{CC} - 2\text{ V}$	-40°C		343	mA
			25°C		370	
			85°C		380	
I_{IN}	Input current	Includes pullup/pulldown resistors	-40°C, 25°C, 85°C		150	μA
V_{BB}	Internally generated bias voltage	$V_{EE} = -3\text{ to }-3.8\text{ V}$, $I_{BB} = -0.2\text{ mA}$	-40°C	$V_{CC} - 1.38$	$V_{CC} - 1.26$	V
			25°C	$V_{CC} - 1.42$	$V_{CC} - 1.26$	
			85°C	$V_{CC} - 1.45$	$V_{CC} - 1.26$	
		$V_{EE} = -2.375\text{ to }-2.75\text{ V}$, $I_{BB} = -0.2\text{ mA}$	-40°C, 25°C, 85°C	$V_{CC} - 1.38$	$V_{CC} - 1.16$	
V_{IH}	High-level input voltage (CLK_SEL)	-40°C, 25°C, 85°C		$V_{CC} - 1.165$	$V_{CC} - 0.88$	V
V_{IL}	Low-level input voltage (CLK_SEL)	-40°C, 25°C, 85°C		$V_{CC} - 1.81$	$V_{CC} - 1.475$	V
V_{INPP}	Input amplitude (CLK0, $\overline{\text{CLK0}}$)	Difference of input 9 $V_{IH}-V_{IL}$, see Note (1)	-40°C, 25°C, 85°C	0.5	1.3	V
V_{IC}	Common-mode voltage (CLK0, $\overline{\text{CLK0}}$)	Cross point of input 9 average (V_{IH} , V_{IL})	-40°C, 25°C, 85°C	1	$V_{CC} - 0.3$	V

(1) V_{INPP} minimum and maximum is required to maintain ac specifications, actual device function tolerates a minimum V_{INPP} of 100 mV.

LVPECL/HSTL DC ELECTRICAL CHARACTERISTICS (continued)

Vsupply: $V_{CC} = 2.375\text{ V to }3.8\text{ V}$, $V_{EE} = 0\text{ V}$

PARAMETER	TEST CONDITIONS	MIN	TYP	MAX	UNIT
V_{ID}	Differential input voltage (CLK1, $\overline{\text{CLK1}}$) Difference of input $V_{IH}-V_{IL}$, See Note (1)	-40°C, 25°C, 85°C	0.4	1.9	V
$V_{I(x)}$	Input crossover voltage (CLK1, $\overline{\text{CLK1}}$) Cross point of input 9 average (V_{IH} , V_{IL})	-40°C, 25°C, 85°C	0.68	0.9	V
V_{OH}	High-level output voltage $I_{OH} = -21\text{ mA}$	-40°C	$V_{CC} - 1.26$	$V_{CC} - 0.9$	V
		25°C	$V_{CC} - 1.2$	$V_{CC} - 0.9$	
		85°C	$V_{CC} - 1.15$	$V_{CC} - 0.9$	
V_{OL}	Low-level output voltage $I_{OL} = -5\text{ mA}$	-40°C	$V_{CC} - 1.85$	$V_{CC} - 1.5$	V
		25°C	$V_{CC} - 1.85$	$V_{CC} - 1.45$	
		85°C	$V_{CC} - 1.85$	$V_{CC} - 1.4$	
V_{OD}	Differential output voltage swing Terminated with $50\ \Omega$ to $V_{CC} - 2\text{ V}$, See Figure 4	-40°C, 25°C, 85°C	600		mV

AC ELECTRICAL CHARACTERISTICS

Vsupply: $V_{CC} = 2.375\text{ V to }3.8\text{ V}$, $V_{EE} = 0\text{ V}$ or LVECL/LVPECL input $V_{CC} = 0\text{ V}$, $V_{EE} = -2.375\text{ V to }-3.8\text{ V}$

PARAMETER	TEST CONDITIONS	MIN	TYP	MAX	UNIT
t_{pd}	Differential propagation delay CLK0, $\overline{\text{CLK0}}$ to all Q0, $\overline{\text{Q0}}$... Q9, $\overline{\text{Q9}}$ Input condition: $V_{CM} = 1\text{ V}$, $V_{PP} = 0.5\text{ V}$	-40°C, 25°C, 85°C	230	350	ps
$t_{sk(pp)}$	Part-to-part skew See Note B and Figure 1	-40°C, 25°C, 85°C		70	ps
$t_{sk(o)}$	Output-to-output skew See Note A and Figure 1	-40°C, 25°C, 85°C	15	30	ps
$t_{(JITTER)}$	Cycle-to-cycle RMS jitter	-40°C, 25°C, 85°C		< 1	ps
$f_{(max)}$	Maximum frequency Functional up to 3.5 GHz, timing specifications apply at 1 GHz, see Figure 3	-40°C, 25°C, 85°C		3500	MHz
t_r/t_f	Output rise and fall time (20%, 80%)	-40°C, 25°C, 85°C	100	200	ps

HSTL INPUT

Vsupply: $V_{CC} = 2.375\text{ V to }3.8\text{ V}$, $V_{EE} = 0\text{ V}$

PARAMETER	TEST CONDITIONS	MIN	TYP	MAX	UNIT
t_{pd}	Differential propagation delay CLK0, $\overline{\text{CLK0}}$ to all Q0, $\overline{\text{Q0}}$... Q9, $\overline{\text{Q9}}$ Input condition: $V_x = 0.68\text{ V}$, $V_{dif} = 0.4\text{ V}$	-40°C, 25°C, 85°C	290	370	ps
$t_{sk(pp)}$	Part-to-part skew See Note B and Figure 1	-40°C, 25°C, 85°C		70	ps
$t_{sk(o)}$	Output to output skew See Note A and Figure 1	-40°C, 25°C, 85°C	10	30	ps
$t_{(JITTER)}$	Cycle-to-cycle RMS jitter	-40°C, 25°C, 85°C		<1	ps

HSTL INPUT (continued)

Vsupply: V_{CC} = 2.375 V to 3.8 V, V_{EE} = 0 V

PARAMETER		TEST CONDITIONS	MIN	TYP	MAX	UNIT
f _(max)	Maximum frequency	Functional up to 3.5 GHz, timing specifications apply at 1 GHz, See Figure 4			3500	MHz
t _r /t _f	Output rise and fall time (20%, 80%)		100		200	ps

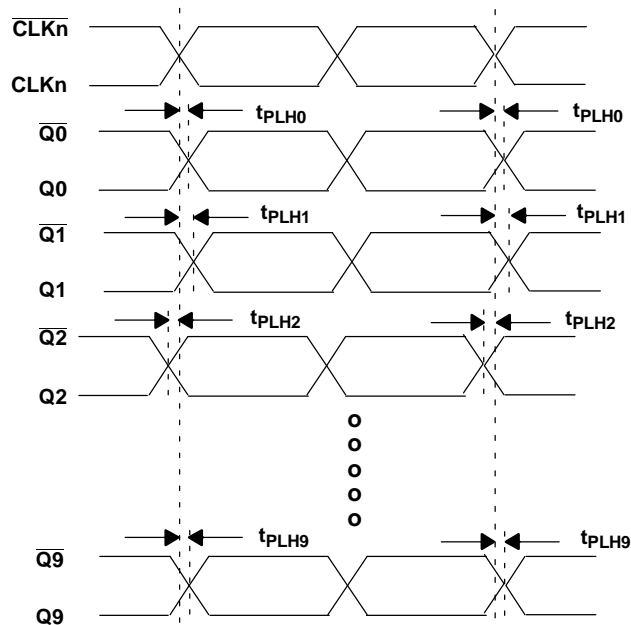

- A. Output skew is calculated as the greater of: The difference between the fastest and the slowest t_{PLHn} (n = 0, 1,...9) or the difference between the fastest and the slowest t_{PHLn} (n = 0, 1,...9).
- B. Part-to-part skew, is calculated as the greater of: The difference between the fastest and the slowest t_{PLHn} (n = 0, 1,...9) across multiple devices or the difference between the fastest and the slowest t_{PHLn} (n = 0, 1,...9) across multiple devices.

Figure 1. Waveform for Calculating Both Output and Part-to-Part Skew

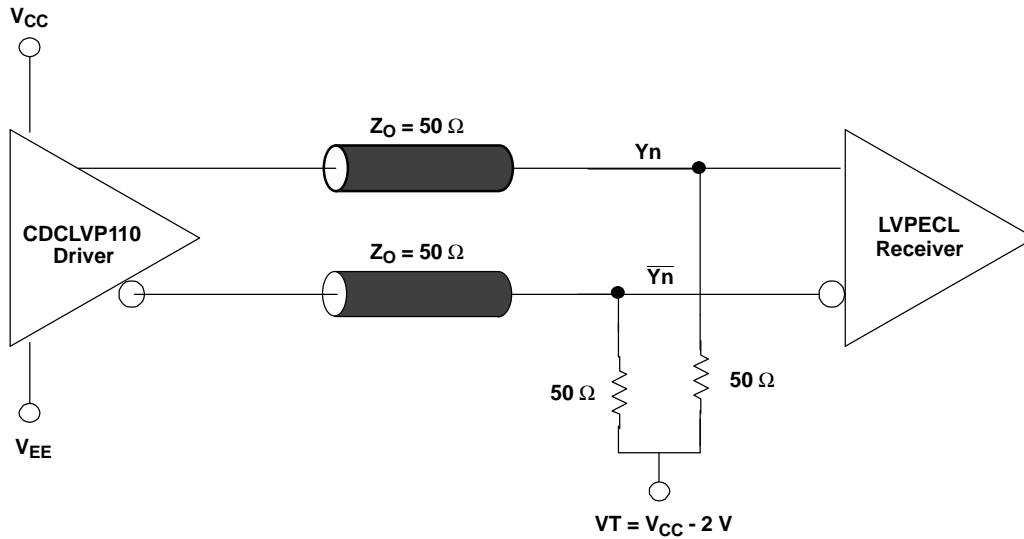

Figure 2. Typical Termination for Output Driver (See the Interfacing Between LVPECL, LVDS, and CML Application Note, Literature Number SCAA056)

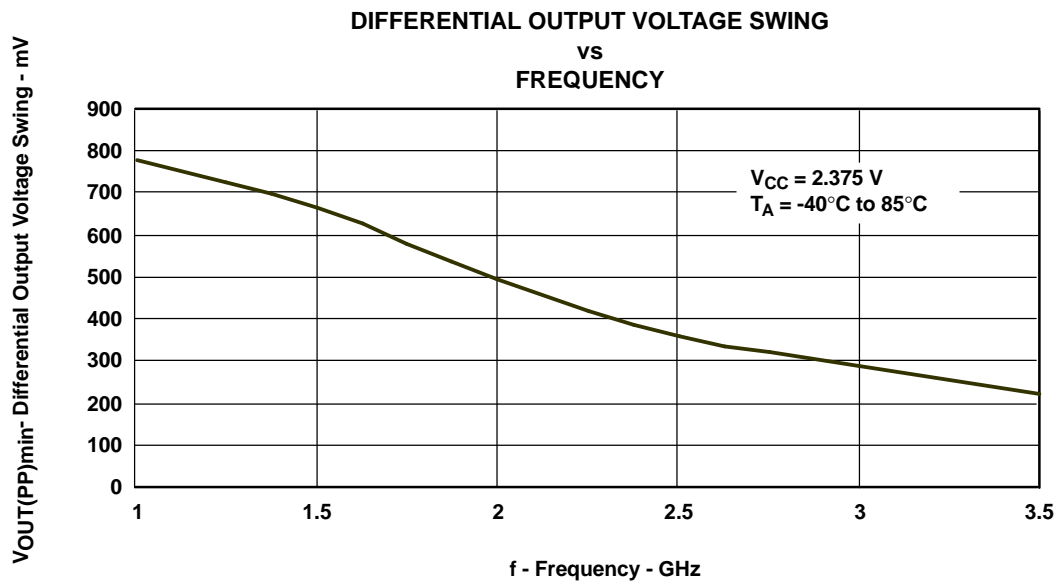

Figure 3. LVPECL Input Using CLK0 Pair, $V_{CM} = 1V$, $V_{IN_{dif}} = 0.5V$

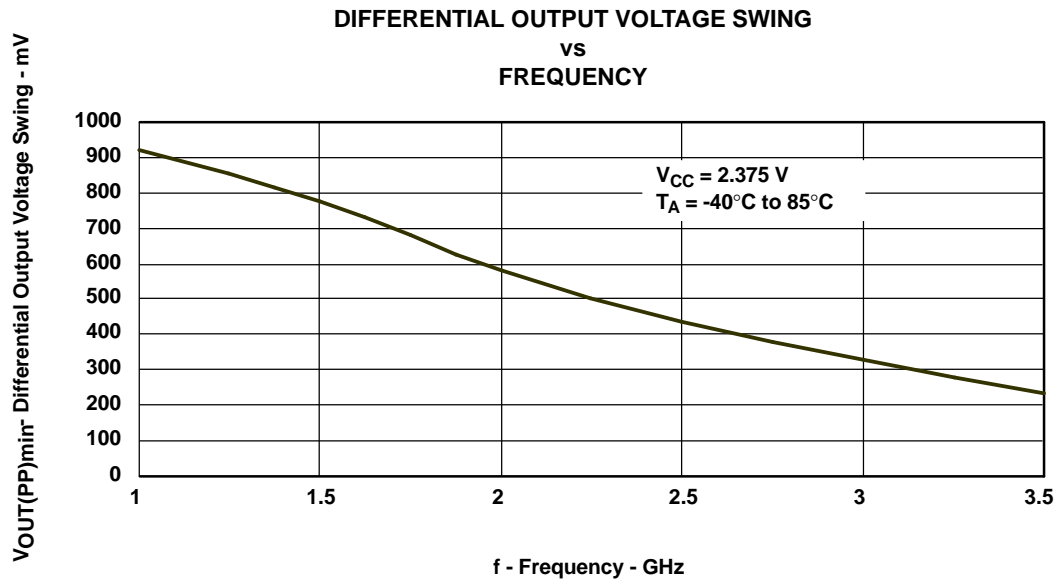

Figure 4. HSTL Input Using CLK1 Pair, $V_{CM} = 0.68\text{ V}$, $V_{IN_{dif}} = 0.4\text{ V}$

PACKAGE INFORMATION

Orderable Device	Status (1)	Pkg Type	Pkg Drawing	Pins	Pkg Qty	Eco Plan (2)	Lead/ Ball Finish	MSL Peak Temp (3)
CDCLVP110VF	ACTIVE	LQFP	VF	32	250	Green (RoHS & no Sb/ Br)	CU NIPDAU	Level-1-260C-UNLIM
CDCLVP110VFG4	ACTIVE	LQFP	VF	32	250	Green (RoHS & no Sb/ Br)	CU NIPDAU	Level-1-260C-UNLIM
CDCLVP110VFR	ACTIVE	LQFP	VF	32	1000	Green (RoHS & no Sb/ Br)	CU NIPDAU	Level-1-260C-UNLIM
CDCLVP110VFRG4	ACTIVE	LQFP	VF	32	1000	Green (RoHS & no Sb/ Br)	CU NIPDAU	Level-1-260C-UNLIM
CDCLVP110MVFR*	ACTIVE	LQFP	VF	32	1000	Green (RoHS & no Sb/ Br)	CU NIPDAU	Level-1-260C-UNLIM

* CDCLVP110MVFR equivalent to the CDCLVP110VFR except for Pin 1 orientation. Pin 1 for the CDCLVP110MVFR is in Quadrant-1 instead of the standard orientation as in the CDCLVP110VFR where Pin 1 is in Quadrant-2.

(1) The marketing status values are defined as follows:

ACTIVE Product device recommended for new designs.

LIFEBUY: TI has announced that the device will be discontinued, and a lifetime-buy period is in effect.

NRND: Not recommended for new designs. Device is in production to support existing customers, but TI does not recommend using this part in a new design.

PREVIEW: Device has been announced but is not in production. Samples may or may not be available.

OBSOLETE TI has discontinued the production of the device.

(2) Eco Plan -The planned eco-friendly classification: Pb-Free (RoHS), Pb-Free (RoHS Exempt), or Green (RoHS & no Sb/Br) -please check <http://www.ti.com/productcontent> for the latest availability information and additional product content details.

TBD: The Pb-Free/Green conversion plan has not been defined.

Pb-Free (RoHS): TI's terms "Lead-Free" or "Pb-Free" mean semiconductor products that are compatible with the current RoHS requirements for all 6 substances, including the requirement that lead not exceed 0.1% by weight in homogeneous materials. Where designed to be soldered at high temperatures, TI Pb-Free products are suitable for use in specified lead-free processes.

Pb-Free (RoHS Exempt): This component has a RoHS exemption for either 1) lead-based flip-chip solder bumps used between the die and package, or 2) lead-based die adhesive used between the die and lead frame. The component is otherwise considered Pb-Free (RoHS compatible) as defined above.

Green (RoHS & no Sb/Br): TI defines "Green" to mean Pb-Free (RoHS compatible), and free of Bromine (Br) and Antimony (Sb) based flame retardants (Br or Sb do not exceed 0.1% by weight in homogeneous material)

(3) MSL, Peak Temp. --The Moisture Sensitivity Level rating according to the JEDEC industry standard classifications and peak solder temperature.

Important Information and Disclaimer: The information provided on this page represents TI's knowledge and belief as of the date that it is provided. TI bases its knowledge and belief on information provided by third parties, and makes no representation or warranty as to the accuracy of such information. Efforts are underway to better integrate information from third parties. TI has taken and continues to take reasonable steps to provide representative and accurate information but may not have conducted destructive testing or chemical analysis on incoming materials and chemicals. TI and TI suppliers consider certain information to be proprietary, and thus CAS numbers and other limited information may not be available for release.

In no event shall TI's liability arising out of such information exceed the total purchase price of the TI part(s) at issue in this document sold by TI to Customer on an annual basis.

TAPE AND REEL INFORMATION

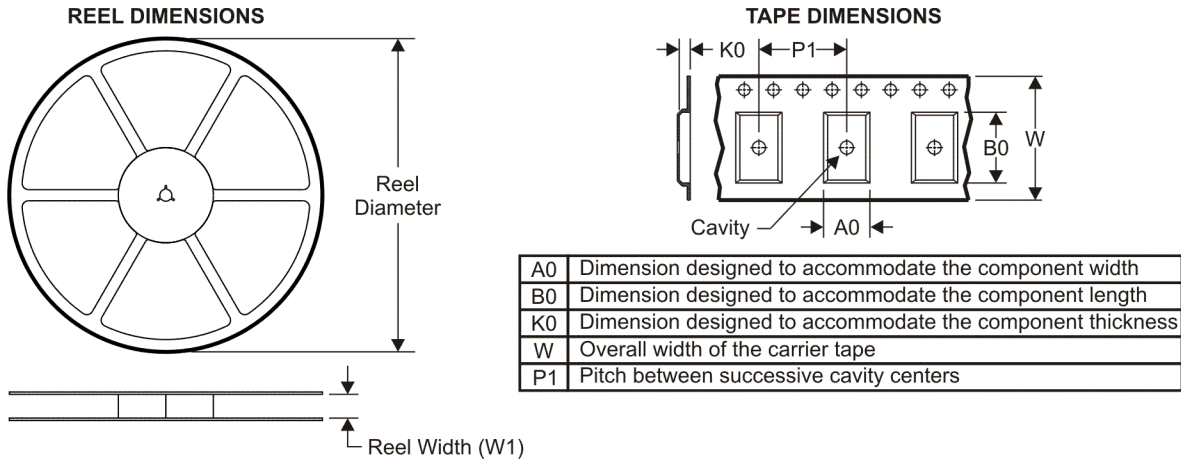

QUADRANT ASSIGNMENTS FOR PIN 1 ORIENTATION IN TAPE



*All dimensions are nominal

Device	Package Type	Package Drawing	Pins	SPQ	Reel Diameter (mm)	Reel Width W1 (mm)	A0 (mm)	B0 (mm)	K0 (mm)	P1 (mm)	W (mm)	Pin1 Quadrant
CDCLVP110MVFR	LQFP	VF	32	1000	330.0	16.4	9.6	9.6	1.9	12.0	16.0	Q1
CDCLVP110VFR	LQFP	VF	32	1000	330.0	16.4	9.6	9.6	1.9	12.0	16.0	Q2

TAPE AND REEL BOX DIMENSIONS



*All dimensions are nominal

Device	Package Type	Package Drawing	Pins	SPQ	Length (mm)	Width (mm)	Height (mm)
CDCLVP110MVFR	LQFP	VF	32	1000	333.2	345.9	28.6
CDCLVP110VFR	LQFP	VF	32	1000	333.2	345.9	28.6

VF (S-PQFP-G32)

PLASTIC QUAD FLATPACK

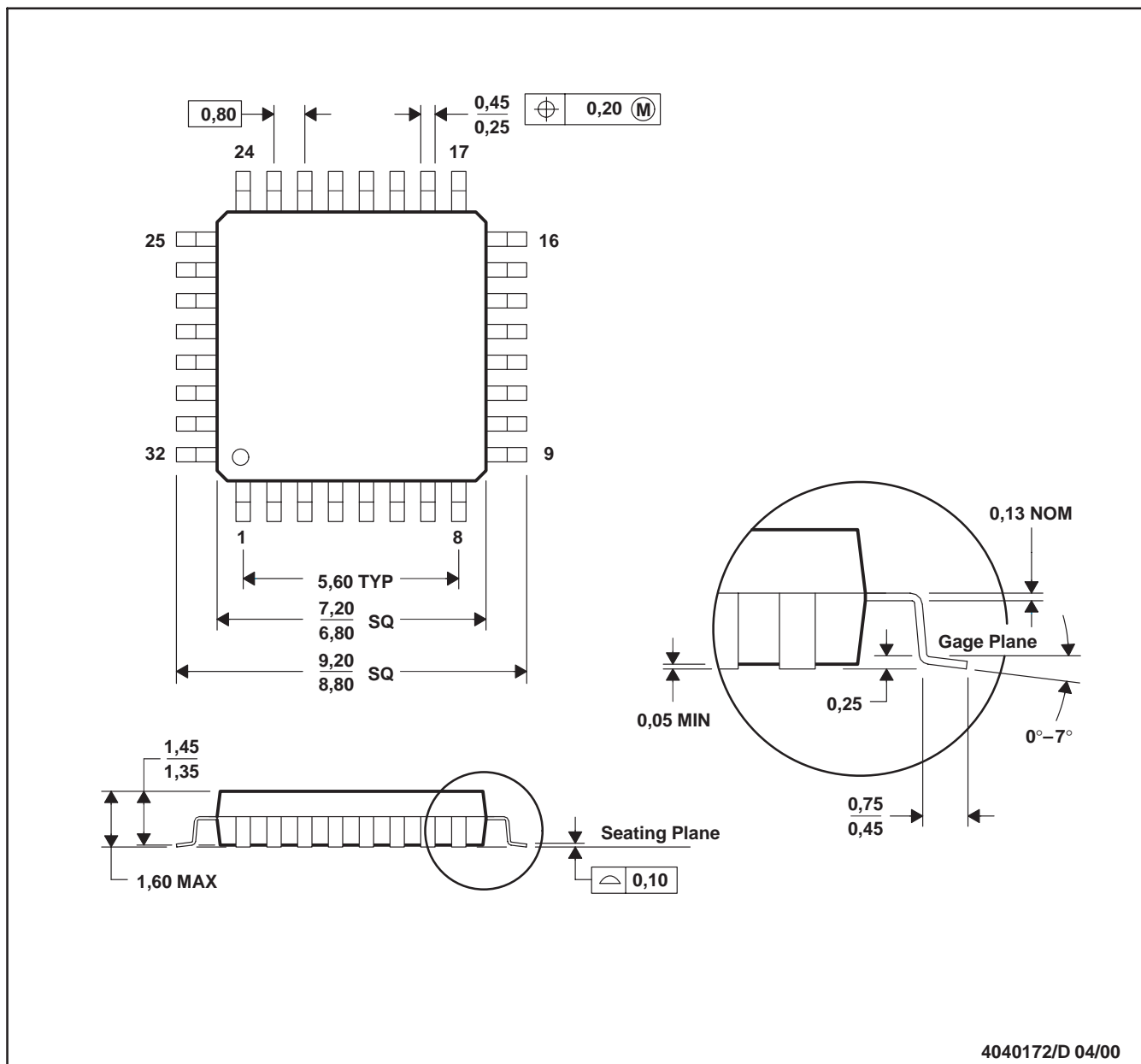

NOTES: A. All linear dimensions are in millimeters.
 B. This drawing is subject to change without notice.

IMPORTANT NOTICE

Texas Instruments Incorporated and its subsidiaries (TI) reserve the right to make corrections, modifications, enhancements, improvements, and other changes to its products and services at any time and to discontinue any product or service without notice. Customers should obtain the latest relevant information before placing orders and should verify that such information is current and complete. All products are sold subject to TI's terms and conditions of sale supplied at the time of order acknowledgment.

TI warrants performance of its hardware products to the specifications applicable at the time of sale in accordance with TI's standard warranty. Testing and other quality control techniques are used to the extent TI deems necessary to support this warranty. Except where mandated by government requirements, testing of all parameters of each product is not necessarily performed.

TI assumes no liability for applications assistance or customer product design. Customers are responsible for their products and applications using TI components. To minimize the risks associated with customer products and applications, customers should provide adequate design and operating safeguards.

TI does not warrant or represent that any license, either express or implied, is granted under any TI patent right, copyright, mask work right, or other TI intellectual property right relating to any combination, machine, or process in which TI products or services are used. Information published by TI regarding third-party products or services does not constitute a license from TI to use such products or services or a warranty or endorsement thereof. Use of such information may require a license from a third party under the patents or other intellectual property of the third party, or a license from TI under the patents or other intellectual property of TI.

Reproduction of TI information in TI data books or data sheets is permissible only if reproduction is without alteration and is accompanied by all associated warranties, conditions, limitations, and notices. Reproduction of this information with alteration is an unfair and deceptive business practice. TI is not responsible or liable for such altered documentation. Information of third parties may be subject to additional restrictions.

Resale of TI products or services with statements different from or beyond the parameters stated by TI for that product or service voids all express and any implied warranties for the associated TI product or service and is an unfair and deceptive business practice. TI is not responsible or liable for any such statements.

TI products are not authorized for use in safety-critical applications (such as life support) where a failure of the TI product would reasonably be expected to cause severe personal injury or death, unless officers of the parties have executed an agreement specifically governing such use. Buyers represent that they have all necessary expertise in the safety and regulatory ramifications of their applications, and acknowledge and agree that they are solely responsible for all legal, regulatory and safety-related requirements concerning their products and any use of TI products in such safety-critical applications, notwithstanding any applications-related information or support that may be provided by TI. Further, Buyers must fully indemnify TI and its representatives against any damages arising out of the use of TI products in such safety-critical applications.

TI products are neither designed nor intended for use in military/aerospace applications or environments unless the TI products are specifically designated by TI as military-grade or "enhanced plastic." Only products designated by TI as military-grade meet military specifications. Buyers acknowledge and agree that any such use of TI products which TI has not designated as military-grade is solely at the Buyer's risk, and that they are solely responsible for compliance with all legal and regulatory requirements in connection with such use.

TI products are neither designed nor intended for use in automotive applications or environments unless the specific TI products are designated by TI as compliant with ISO/TS 16949 requirements. Buyers acknowledge and agree that, if they use any non-designated products in automotive applications, TI will not be responsible for any failure to meet such requirements.

Following are URLs where you can obtain information on other Texas Instruments products and application solutions:

Products

Amplifiers	amplifier.ti.com
Data Converters	dataconverter.ti.com
DSP	dsp.ti.com
Clocks and Timers	www.ti.com/clocks
Interface	interface.ti.com
Logic	logic.ti.com
Power Mgmt	power.ti.com
Microcontrollers	microcontroller.ti.com
RFID	www.ti-rfid.com
RF/IF and ZigBee® Solutions	www.ti.com/lprf

Applications

Audio	www.ti.com/audio
Automotive	www.ti.com/automotive
Broadband	www.ti.com/broadband
Digital Control	www.ti.com/digitalcontrol
Medical	www.ti.com/medical
Military	www.ti.com/military
Optical Networking	www.ti.com/opticalnetwork
Security	www.ti.com/security
Telephony	www.ti.com/telephony
Video & Imaging	www.ti.com/video
Wireless	www.ti.com/wireless

Mailing Address: Texas Instruments, Post Office Box 655303, Dallas, Texas 75265
Copyright © 2008, Texas Instruments Incorporated