

Dual 1:6 Low Additive Jitter LVDS Buffer

Check for Samples: [CDCLVD2106](#)

FEATURES

- Dual 1:6 Differential Buffer
- Low Additive Jitter: $\lt; 300\text{ fs rms}$ in 10 kHz – 20 MHz
- Low Within Bank Output Skew of 45 ps (Max)
- Universal Inputs Accept LVDS, LVPECL, LVCMOS
- One Input Dedicated for Six Outputs
- Total of 12 LVDS Outputs, ANSI EIA/TIA-644A Standard Compatible
- Clock Frequency up to 800 MHz
- 2.375–2.625 V Device Power Supply
- LVDS Reference Voltage, V_{AC_REF} , Available for Capacitive Coupled Inputs
- Industrial Temperature Range -40°C to 85°C
- Packaged in 6 mm x 6 mm 40-pin QFN (RHA)
- ESD Protection Exceeds 3-kV HBM, 1-kV CDM

APPLICATIONS

- Telecommunications/Networking
- Medical Imaging
- Test and Measurement Equipment
- Wireless Communications
- General Purpose Clocking

DESCRIPTION

The CDCLVD2106 clock buffer distributes two clock inputs (IN0, IN1) to a total of 12 pairs of differential LVDS clock outputs (OUT0, OUT11). Each buffer block consists of one input and 6 LVDS outputs. The inputs can either be LVDS, LVPECL, or LVCMOS.

The CDCLVD2106 is specifically designed for driving 50- Ω transmission lines. In case of driving the inputs in single ended mode, the appropriate bias voltage (V_{AC_REF}) should be applied to the unused negative input pin.

Using the control pin (EN), outputs can be either disabled or enabled. If the EN pin is left open two buffers with all outputs are enabled, if switched to a logical "0" both buffers with all outputs are disabled (static logical "0"), if switched to a logical "1", one buffer with six outputs is disabled and another buffer with six outputs is enabled. The part supports a fail safe function. It incorporates an input hysteresis, which prevents random oscillation of the outputs in absence of an input signal.

The device operates in 2.5V supply environment and is characterized from -40°C to 85°C (ambient temperature). The CDCLVD2106 is packaged in small 40-pin, 6-mm x 6-mm QFN package.

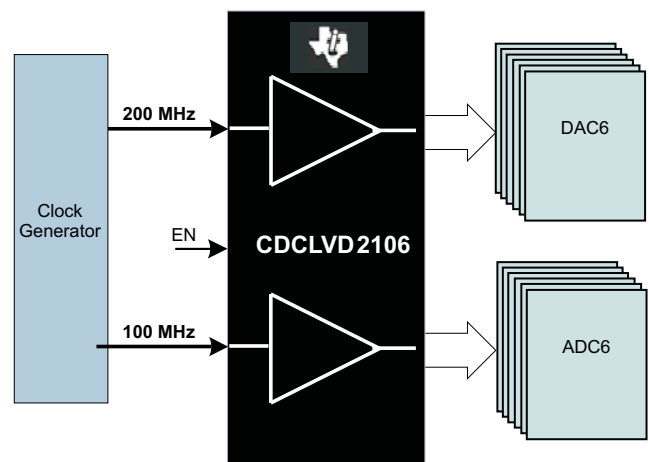

Figure 1. Application Example



Please be aware that an important notice concerning availability, standard warranty, and use in critical applications of Texas Instruments semiconductor products and disclaimers thereto appears at the end of this data sheet.



These devices have limited built-in ESD protection. The leads should be shorted together or the device placed in conductive foam during storage or handling to prevent electrostatic damage to the MOS gates.

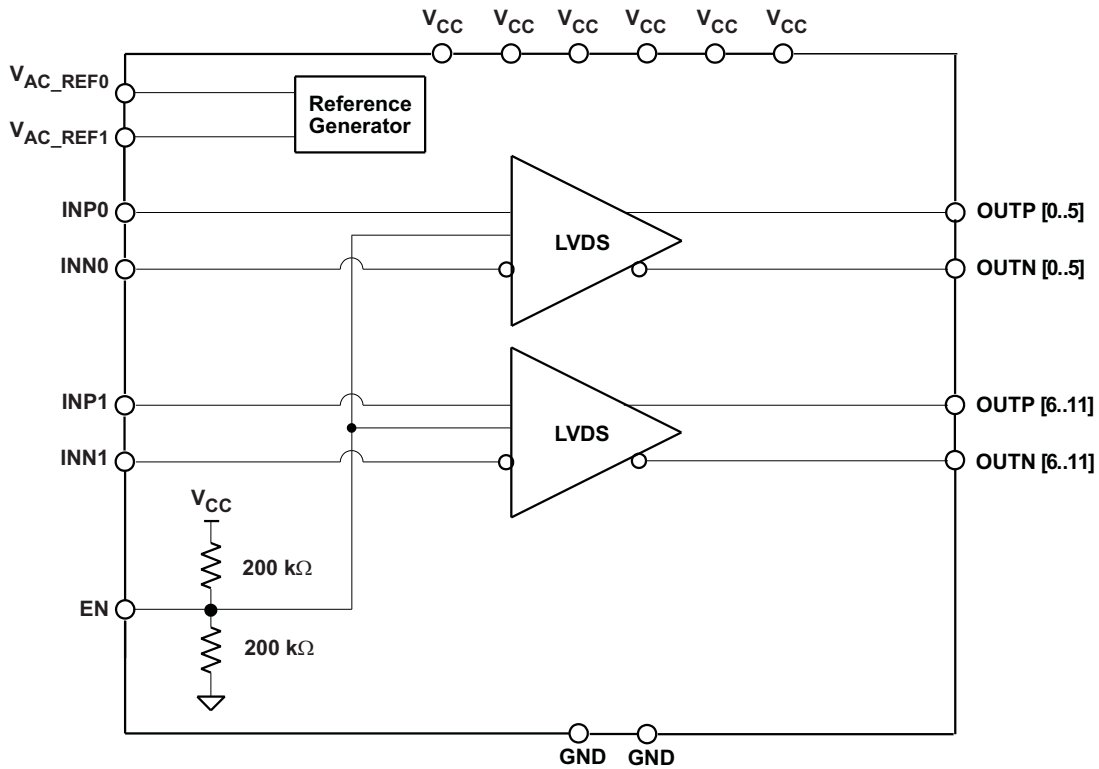
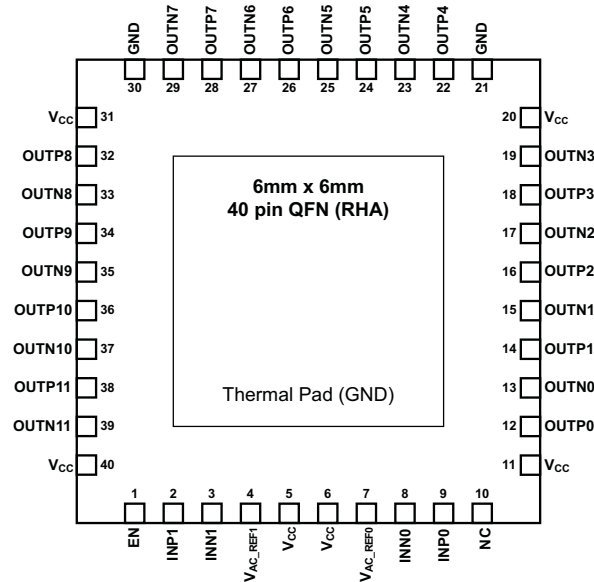

Figure 2. CDCLVD2106 Block Diagram



PIN FUNCTIONS

PIN			
NAME	NO.	TYPE	DESCRIPTION
V _{CC}	5, 6, 11, 20, 31, 40	Power	2.5V supplies for the device
GND	21, 30	Ground	Device ground
INP0, INN0	9, 8	Input	Differential input pair or single ended input
INP1, INN1	2, 3	Input	Differential redundant input pair or single ended input
OUTP0, OUTN0	12, 13	Output	Differential LVDS output pair no. 0
OUTP1, OUTN1	14, 15	Output	Differential LVDS output pair no. 1
OUTP2, OUTN2	16, 17	Output	Differential LVDS output pair no. 2
OUTP3, OUTN3	18, 19	Output	Differential LVDS output pair no. 3
OUTP4, OUTN4	22, 23	Output	Differential LVDS output pair no. 4
OUTP5, OUTN5	24, 25	Output	Differential LVDS output pair no. 5
OUTP6, OUTN6	26, 27	Output	Differential LVDS output pair no. 6
OUTP7, OUTN7	28, 29	Output	Differential LVDS output pair no. 7
OUTP8, OUTN8	32, 33	Output	Differential LVDS output pair no. 8
OUTP9, OUTN9	34, 35	Output	Differential LVDS output pair no. 9
OUTP10, OUTN10	36, 37	Output	Differential LVDS output pair no. 10
OUTP11, OUTN11	38, 39	Output	Differential LVDS output pair no. 11
V _{AC_REF0}	7	Output	Bias voltage output for capacitive coupled inputs. If used, it is recommended to use a 0.1µF to GND on this pin.
V _{AC_REF1}	4	Output	Bias voltage output for capacitive coupled inputs. If used, it is recommended to use a 0.1µF to GND on this pin.
NC	10		No connect
EN	1	Input with internal 200kΩ pull-up and pull-down	Control pin – enables or disables the outputs (See Table 1).
Thermal Pad		Ground	Device ground. Thermal pad must be soldered to ground. See thermal management recommendations.

Table 1. Output Control Table

EN	CLOCK OUTPUTS
0	All outputs disabled (static "0")
Open	All outputs enabled
1	OUT0 to OUT5 enabled and OUT6 to OUT11 disabled (static "0")

ABSOLUTE MAXIMUM RATINGS

over operating free-air temperature range (unless otherwise noted) ⁽¹⁾

	VALUE	UNIT
Supply voltage range, V_{CC}	-0.3 to 2.8	V
Input voltage range, V_I	-0.2 to ($V_{CC} + 0.2$)	V
Output voltage range, V_O	-0.2 to ($V_{CC} + 0.2$)	V
Driver short circuit current, I_{OSD}	See note ⁽²⁾	
Electrostatic discharge (HBM, 1.5 k Ω , 100 pF)	>3000	V

- (1) Stresses beyond those listed under “absolute maximum ratings” may cause permanent damage to the device. These are stress ratings only and functional operation of the device at these or any other conditions beyond those indicated under recommended operating conditions is not implied. Exposure to absolute-maximum-rated conditions for extended periods may affect device reliability.
- (2) The outputs can handle permanent short.

RECOMMENDED OPERATING CONDITIONS

	MIN	TYP	MAX	UNIT
Device supply voltage, V_{CC}	2.375	2.5	2.625	V
Ambient temperature, T_A	-40		85	°C

THERMAL INFORMATION

THERMAL METRIC ⁽¹⁾		CDCLVD2106	UNITS
		RHA (40 PINS)	
θ_{JA}	Junction-to-ambient thermal resistance	31.0	°C/W
$\theta_{JC(top)}$	Junction-to-case(top) thermal resistance	28.7	
θ_{JB}	Junction-to-board thermal resistance	9.3	
ψ_{JT}	Junction-to-top characterization parameter	0.4	
ψ_{JB}	Junction-to-board characterization parameter	9.3	
$\theta_{JC(bottom)}$	Junction-to-case(bottom) thermal resistance	3.1	

- (1) For more information about traditional and new thermal metrics, see the *IC Package Thermal Metrics* application report, [SPRA953](#).

ELECTRICAL CHARACTERISTICS

At $V_{CC} = 2.375V$ to $2.625V$, $T_A = -40^\circ C$ to $85^\circ C$ (unless otherwise noted)

PARAMETER		TEST CONDITIONS	MIN	TYP	MAX	UNIT
EN CONTROL INPUT CHARACTERISTICS						
V_{dI3}	3 State	Open		$0.5 \times V_{CC}$		V
V_{dIH}	Input high voltage		$0.7 \times V_{CC}$			V
V_{dIL}	Input low voltage			$0.2 \times V_{CC}$		V
I_{dIH}	Input high current	$V_{CC} = 2.625 V$, $V_{IH} = 2.625 V$			30	μA
I_{dIL}	Input low current	$V_{CC} = 2.625 V$, $V_{IL} = 0 V$			-30	μA
$R_{pull(EN)}$	Input pull-up/ pull-down resistor			200		k Ω
2.5V LVC MOS (see Figure 7) INPUT CHARACTERISTICS						
f_{IN}	Input frequency				200	MHz
V_{th}	Input threshold voltage	External threshold voltage applied to complementary input	1.1		1.5	V
V_{IH}	Input high voltage		$V_{th} + 0.1$		V_{CC}	V
V_{IL}	Input low voltage		0		$V_{th} - 0.1$	V
I_{IH}	Input high current	$V_{CC} = 2.625 V$, $V_{IH} = 2.625 V$			10	μA
I_{IL}	Input low current	$V_{CC} = 2.625 V$, $V_{IL} = 0 V$			-10	μA
$\Delta V/\Delta T$	Input edge rate	20%–80%	1.5			V/ns
C_{IN}	Input capacitance			2.5		pF

ELECTRICAL CHARACTERISTICS (continued)

 At $V_{CC} = 2.375V$ to $2.625V$, $T_A = -40^{\circ}C$ to $85^{\circ}C$ (unless otherwise noted)

PARAMETER		TEST CONDITIONS	MIN	TYP	MAX	UNIT
DIFFERENTIAL INPUT CHARACTERISTICS						
f_{IN}	Input frequency	Clock input			800	MHz
$V_{IN, DIFF}$	Differential input voltage peak-to-peak	$V_{ICM} = 1.25 V$	0.3		1.6	V_{PP}
V_{ICM}	Input common mode voltage range	$V_{IN, DIFF, PP} > 0.4 V$	1.0		$V_{CC} - 0.3$	V
I_{IH}	Input high current	$V_{CC} = 2.625 V$, $V_{IH} = 2.625 V$			10	μA
I_{IL}	Input low current	$V_{CC} = 2.625$, $V_{IL} = 0 V$			-10	μA
$\Delta V/\Delta T$	Input edge rate	20%–80%	0.75			V/ns
C_{IN}	Input capacitance			2.5		pF
LVDS OUTPUT CHARACTERISTICS						
$ V_{OD} $	Differential output voltage magnitude	$V_{IN, DIFF, PP} = 0.3V$, $R_L = 100 \Omega$	250		450	mV
ΔV_{OD}	Change in differential output voltage magnitude		-15		15	mV
$V_{OC(SS)}$	Steady-state common mode output voltage		1.1		1.375	V
$\Delta V_{OC(SS)}$	Steady-state common mode output voltage	$V_{IN, DIFF, PP} = 0.6V$, $R_L = 100 \Omega$	-15		15	mV
V_{ring}	Output overshoot and undershoot	Percentage of output amplitude V_{OD}			10%	
V_{OS}	Output ac common mode	$V_{IN, DIFF, PP} = 0.6V$, $R_L = 100 \Omega$		40	70	mV_{P-P}
I_{OS}	Short-circuit output current	$V_{OD} = 0 V$			± 24	mA
t_{PD}	Propagation delay	$V_{IN, DIFF, PP} = 0.3 V$		1.5	2.5	ns
$t_{SK, PP}$	Part-to-part skew				600	ps
t_{SK,O_WB}	Within bank output skew				45	ps
t_{SK,O_BB}	Bank-to-bank output skew	Both inputs are phase aligned			75	ps
$t_{SK,P}$	Pulse skew(with 50% duty cycle input)	Crossing-point-to-crossing-point distortion	-50		50	ps
t_{RJIT}	Random additive jitter (with 50% duty cycle input)	Edge speed = 0.75 V/ns, 10 kHz – 20 MHz			0.3	ps, RMS
t_R/t_F	Output rise/fall time	20% to 80%, 100 Ω , 5 pF	50		300	ps
I_{CCSTAT}	Static supply current	Outputs unterminated, $f = 0$ Hz		27	45	mA
I_{CC100}	Supply current	All outputs enabled; $R_L = 100 \Omega$, $f = 100$ MHz		97	133	mA
I_{CC800}	Supply current	All outputs enabled; $R_L = 100 \Omega$, $f = 800$ MHz		137	177	mA
V_{AC_REF} CHARACTERISTICS						
V_{AC_REF}	Reference output voltage	$V_{CC} = 2.5 V$, $I_{load} = 100 \mu A$	1.1	1.25	1.35	V

Typical Additive Phase Noise Characteristics for 100 MHz Clock

PARAMETER		MIN	TYP	MAX	UNIT
phn ₁₀₀	Phase noise at 100 Hz offset		-132.9		dBc/Hz
phn _{1k}	Phase noise at 1 kHz offset		-138.8		dBc/Hz
phn _{10k}	Phase noise at 10 kHz offset		-147.4		dBc/Hz
phn _{100k}	Phase noise at 100 kHz offset		-153.6		dBc/Hz
phn _{1M}	Phase noise at 1 MHz offset		-155.2		dBc/Hz
phn _{10M}	Phase noise at 10 MHz offset		-156.2		dBc/Hz
phn _{20M}	Phase noise at 20 MHz offset		-156.6		dBc/Hz
t _{RJIT}	Random additive jitter from 10 kHz to 20 MHz		171		fs, RMS

Typical Additive Phase Noise Characteristics for 737.27 MHz Clock

PARAMETER		MIN	TYP	MAX	UNIT
phn ₁₀₀	Phase noise at 100 Hz offset		-80.2		dBc/Hz
phn _{1k}	Phase noise at 1 kHz offset		-114.3		dBc/Hz
phn _{10k}	Phase noise at 10 kHz offset		-138		dBc/Hz
phn _{100k}	Phase noise at 100 kHz offset		-143.9		dBc/Hz
phn _{1M}	Phase noise at 1 MHz offset		-145.2		dBc/Hz
phn _{10M}	Phase noise at 10 MHz offset		-146.5		dBc/Hz
phn _{20M}	Phase noise at 20 MHz offset		-146.6		dBc/Hz
t _{RJIT}	Random additive jitter from 10 kHz to 20 MHz		65		fs, RMS

TYPICAL CHARACTERISTICS
INPUT- AND OUTPUT-CLOCK PHASE NOISES
 vs
FREQUENCY FROM the CARRIER
 (T_A = 25°C and V_{CC} = 2.5V)

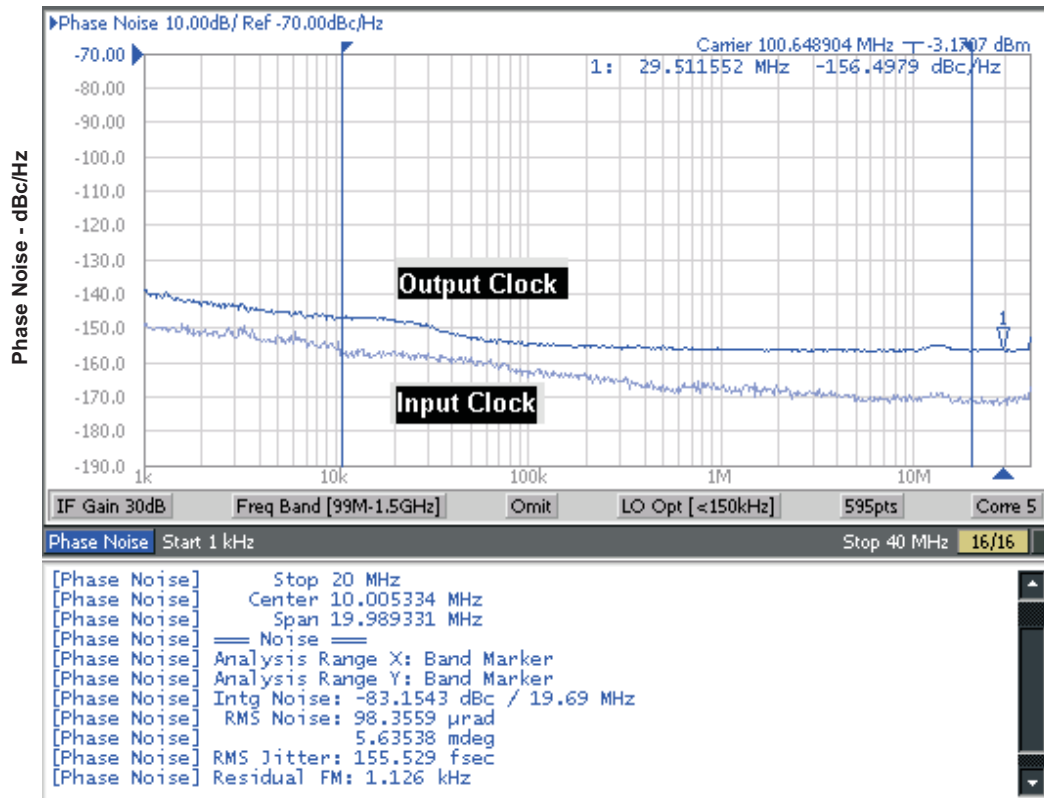

Input clock RMS jitter is 32 fs from 10 kHz to 20 MHz and additive RMS jitter is 152 fs

Figure 3. 100 MHz Input and Output Phase Noise Plots

TYPICAL CHARACTERISTICS (continued)
DIFFERENTIAL OUTPUT VOLTAGE
vs
FREQUENCY

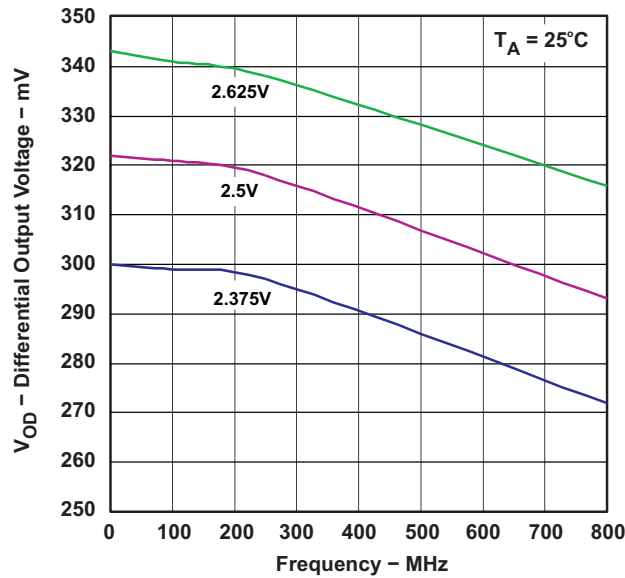

Figure 4. Differential Output Voltage vs Frequency

TEST CONFIGURATIONS

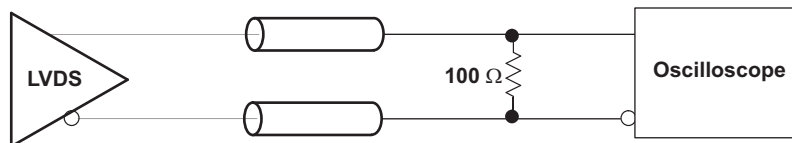

Figure 5. LVDS Output DC Configuration During Device Test

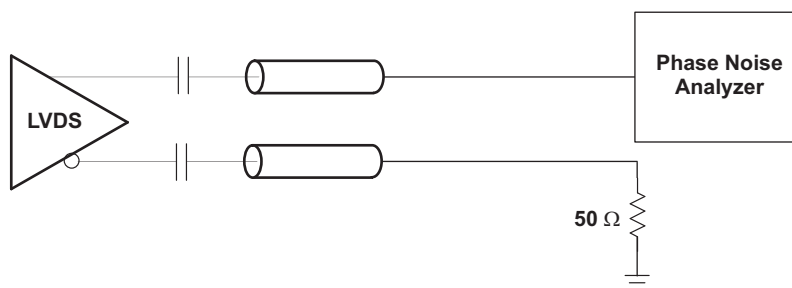

Figure 6. LVDS Output AC Configuration During Device Test

TYPICAL CHARACTERISTICS (continued)

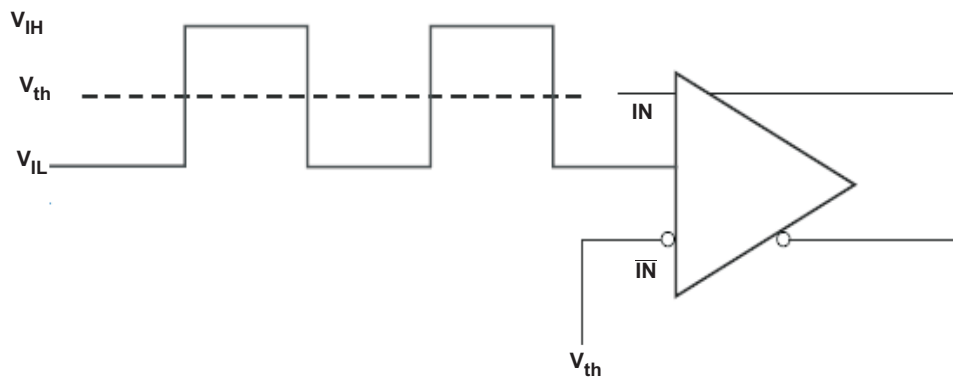

Figure 7. DC Coupled LVCMOS Input During Device Test

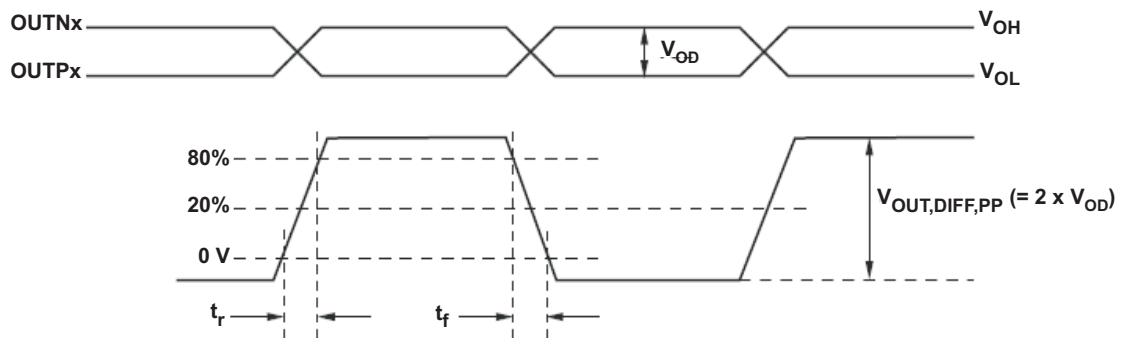
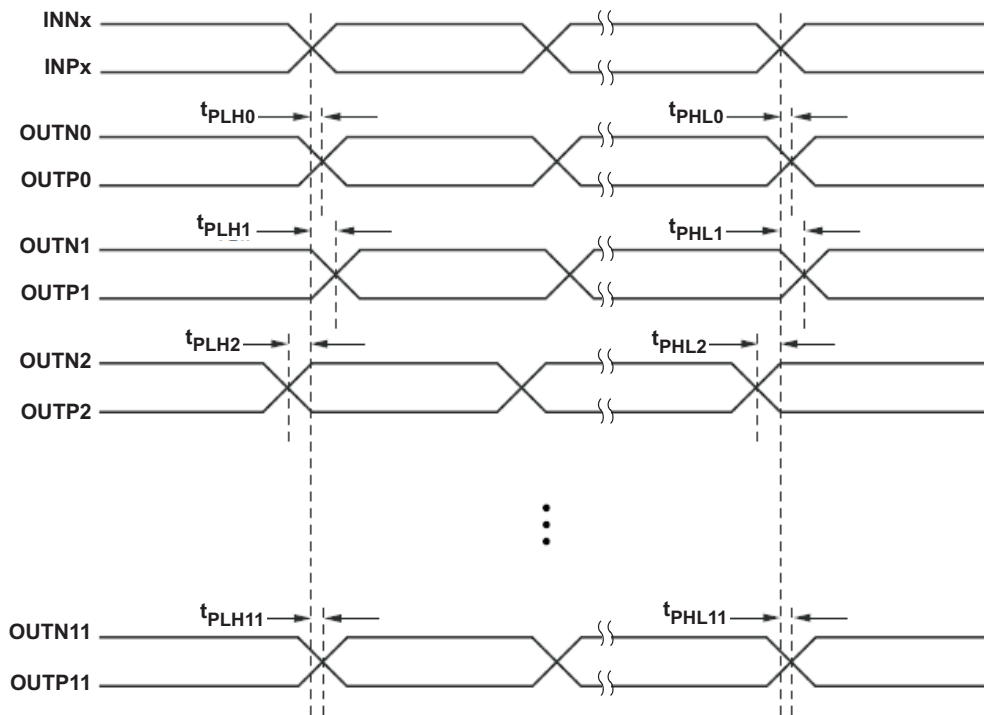

Figure 8. Output Voltage and Rise/Fall Time

TYPICAL CHARACTERISTICS (continued)



- A. Output skew is calculated as the greater of the following: As of the difference between the fastest and the slowest t_{PLHn} or the difference between the fastest and the slowest t_{PHLn} ($n = 0, 1, 2, \dots, 11$)
- B. Part to part skew is calculated as the greater of the following: As the difference between the fastest and the slowest t_{PLHn} or the difference between the fastest and the slowest t_{PHLn} across multiple devices ($n = 0, 1, 2, \dots, 11$)
- C. Both inputs (IN0 and IN1) are phase aligned

Figure 9. Output Skew and Part-to-Part Skew

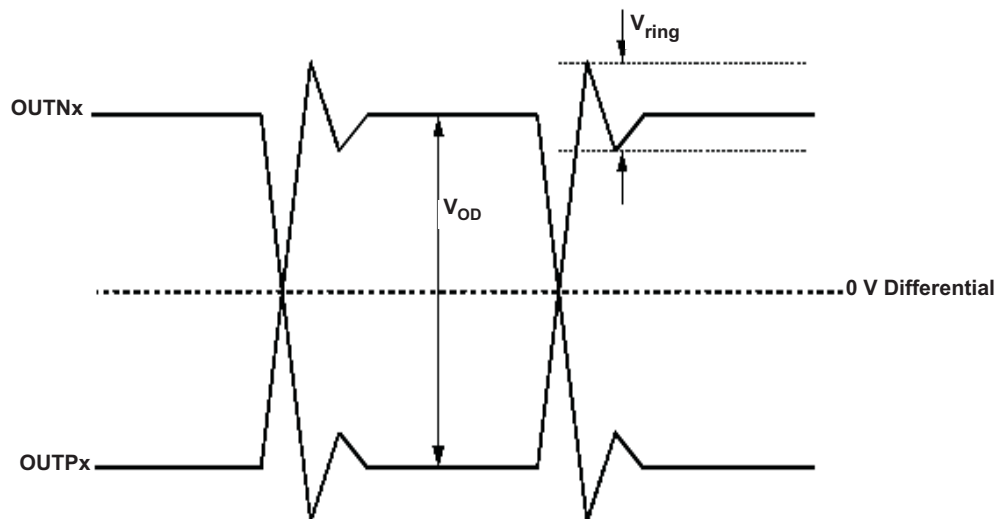

Figure 10. Output Overshoot and Undershoot

TYPICAL CHARACTERISTICS (continued)

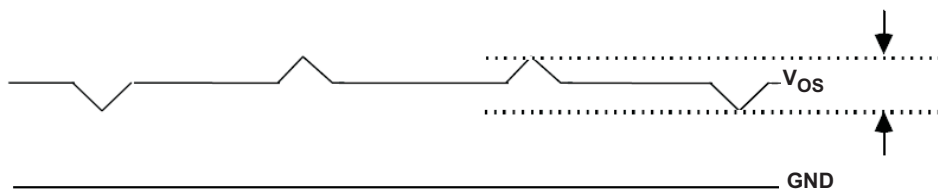

Figure 11. Output AC Common Mode

APPLICATION INFORMATION

THERMAL MANAGEMENT

For reliability and performance reasons, the die temperature should be limited to a maximum of 125°C.

The device package has an exposed pad that provides the primary heat removal path to the printed circuit board (PCB). To maximize the heat dissipation from the package, a thermal landing pattern including multiple vias to a ground plane must be incorporated into the PCB within the footprint of the package. The thermal pad must be soldered down to ensure adequate heat conduction to of the package. Check the mechanical data at the end of the data sheet for land and via pattern examples.

POWER SUPPLY FILTERING

High-performance clock buffers are sensitive to noise on the power supply, which can dramatically increase the additive jitter of the buffer. Thus, it is essential to reduce noise from the system power supply, especially when jitter/phase noise is very critical to the application.

Filter capacitors are used to eliminate the low-frequency noise from the power supply, where the bypass capacitors provide the low impedance path for high-frequency noise and guard the power-supply system against the induced fluctuations. These bypass capacitors also provide instantaneous current surges as required by the device and should have low equivalent series resistance (ESR). To properly use the bypass capacitors, they must be placed very close to the power-supply pins and laid out with short loops to minimize inductance. It is recommended to add as many high-frequency (for example, 0.1 μF) bypass capacitors as there are supply pins in the package. It is recommended, but not required, to insert a ferrite bead between the board power supply and the chip power supply that isolates the high-frequency switching noises generated by the clock driver; these beads prevent the switching noise from leaking into the board supply. Choose an appropriate ferrite bead with very low dc resistance because it is imperative to provide adequate isolation between the board supply and the chip supply, as well as to maintain a voltage at the supply pins that is greater than the minimum voltage required for proper operation.

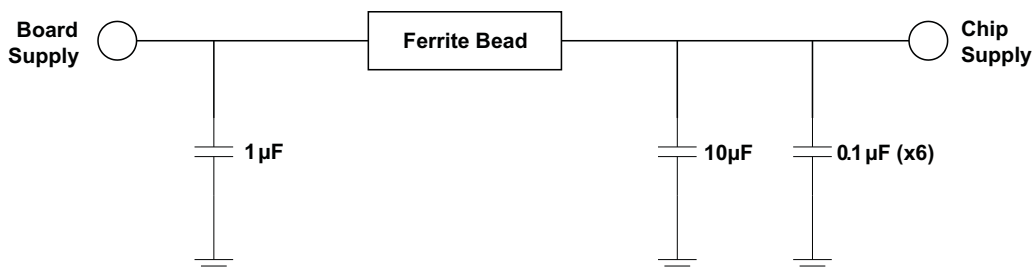

Figure 12. Power Supply Filtering

LVDS OUTPUT TERMINATION

The proper LVDS termination for signal integrity over two $50\ \Omega$ lines is $100\ \Omega$ between the outputs on the receiver end. Either dc-coupled termination or ac-coupled termination can be used for LVDS outputs. It is recommended to place termination resistor close to the receiver. If the receiver is internally biased to a voltage different than the output common mode voltage of the CDCLVD2106, ac-coupling should be used. If the LVDS receiver has internal $100\ \Omega$ termination, external termination must be omitted.

Unused outputs can be left open without connecting any trace to the output pins.

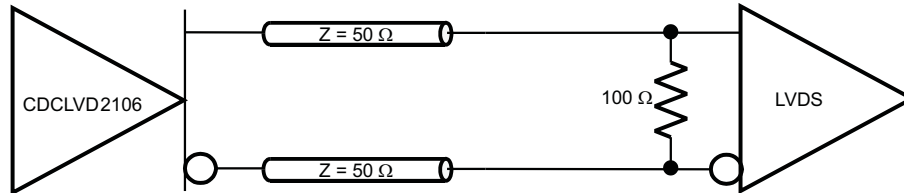

Figure 13. LVDS Output DC Termination

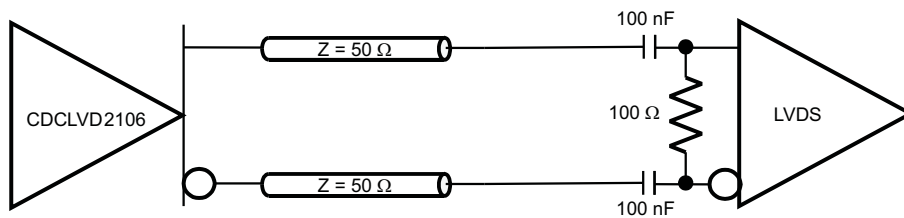

Figure 14. LVDS Output AC Termination with Receiver Internally Biased

INPUT TERMINATION

The CDCLVD2106 inputs can be interfaced with LVDS, LVPECL, or LVCMOS drivers.

LVDS Driver can be connected to CDCLVD2106 inputs with dc or ac coupling as shown [Figure 15](#) and [Figure 16](#) respectively.

[Figure 17](#) shows how to connect LVPECL inputs to the CDCLVD2106. The series resistors are required to reduce the LVPECL signal swing if the signal swing is $>1.6 V_{PP}$.

[Figure 18](#) illustrates how to couple a 2.5 V LVCMOS clock input to the CDCLVD2106 directly. The series resistance (R_S) should be placed close to the LVCMOS driver if needed. 3.3 V LVCMOS clock input swing needs to be limited to $V_{IH} \leq V_{CC}$.

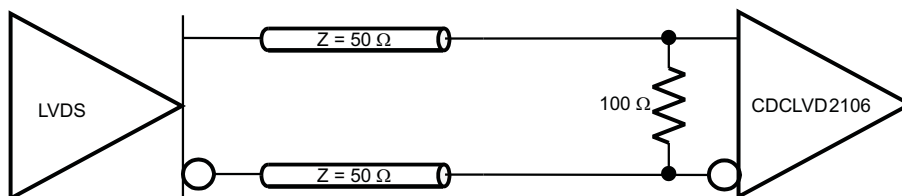

Figure 15. LVDS Clock Driver Connected to CDCLVD2106 Input (DC coupled)

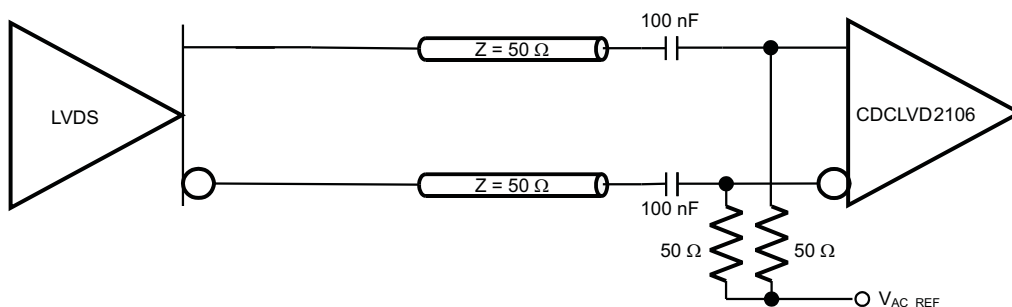

Figure 16. LVDS Clock Driver Connected to CDCLVD2106 Input (AC coupled)

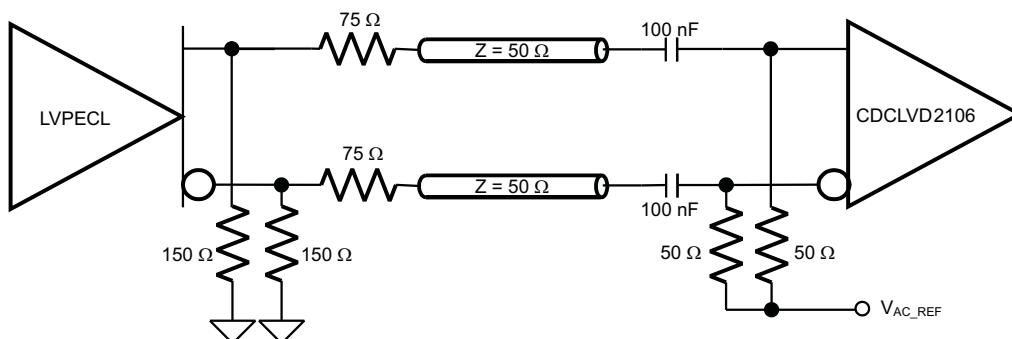

Figure 17. LVPECL Clock Driver Connected to CDCLVD2106 Input

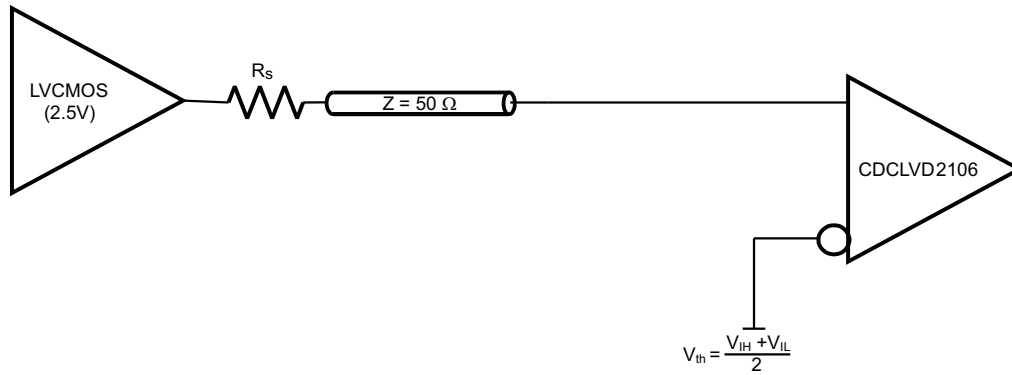

Figure 18. 2.5V LVC MOS Clock Driver Connected to CDCLVD2106 Input

If one of the input buffers is used, then the other buffer should be disabled using the control pin EN; and, unused input pins should be grounded by 1-kΩ resistors.

REVISION HISTORY

Changes from Original (September 2010) to Revision A	Page
• Changed t_{SK,O_BB} Bank-to-bank output slew From: 170 ps (Max) To: 75 ps (Max)	5
• Deleted the Recommended PCB Layout illustration	11
Changes from Revision A (November 2010) to Revision B	Page
• Changed the device status From: Product Preview To: Production	1

PACKAGING INFORMATION

Orderable Device	Status ⁽¹⁾	Package Type	Package Drawing	Pins	Package Qty	Eco Plan ⁽²⁾	Lead/ Ball Finish	MSL Peak Temp ⁽³⁾	Samples (Requires Login)
CDCLVD2106RHAR	ACTIVE	VQFN	RHA	40	2500	Green (RoHS & no Sb/Br)	CU NIPDAU	Level-3-260C-168 HR	
CDCLVD2106RHAT	ACTIVE	VQFN	RHA	40	250	Green (RoHS & no Sb/Br)	CU NIPDAU	Level-3-260C-168 HR	

⁽¹⁾ The marketing status values are defined as follows:

ACTIVE: Product device recommended for new designs.

LIFEBUY: TI has announced that the device will be discontinued, and a lifetime-buy period is in effect.

NRND: Not recommended for new designs. Device is in production to support existing customers, but TI does not recommend using this part in a new design.

PREVIEW: Device has been announced but is not in production. Samples may or may not be available.

OBSOLETE: TI has discontinued the production of the device.

⁽²⁾ Eco Plan - The planned eco-friendly classification: Pb-Free (RoHS), Pb-Free (RoHS Exempt), or Green (RoHS & no Sb/Br) - please check <http://www.ti.com/productcontent> for the latest availability information and additional product content details.

TBD: The Pb-Free/Green conversion plan has not been defined.

Pb-Free (RoHS): TI's terms "Lead-Free" or "Pb-Free" mean semiconductor products that are compatible with the current RoHS requirements for all 6 substances, including the requirement that lead not exceed 0.1% by weight in homogeneous materials. Where designed to be soldered at high temperatures, TI Pb-Free products are suitable for use in specified lead-free processes.

Pb-Free (RoHS Exempt): This component has a RoHS exemption for either 1) lead-based flip-chip solder bumps used between the die and package, or 2) lead-based die adhesive used between the die and leadframe. The component is otherwise considered Pb-Free (RoHS compatible) as defined above.

Green (RoHS & no Sb/Br): TI defines "Green" to mean Pb-Free (RoHS compatible), and free of Bromine (Br) and Antimony (Sb) based flame retardants (Br or Sb do not exceed 0.1% by weight in homogeneous material)

⁽³⁾ MSL, Peak Temp. -- The Moisture Sensitivity Level rating according to the JEDEC industry standard classifications, and peak solder temperature.

Important Information and Disclaimer: The information provided on this page represents TI's knowledge and belief as of the date that it is provided. TI bases its knowledge and belief on information provided by third parties, and makes no representation or warranty as to the accuracy of such information. Efforts are underway to better integrate information from third parties. TI has taken and continues to take reasonable steps to provide representative and accurate information but may not have conducted destructive testing or chemical analysis on incoming materials and chemicals. TI and TI suppliers consider certain information to be proprietary, and thus CAS numbers and other limited information may not be available for release.

In no event shall TI's liability arising out of such information exceed the total purchase price of the TI part(s) at issue in this document sold by TI to Customer on an annual basis.

TAPE AND REEL INFORMATION

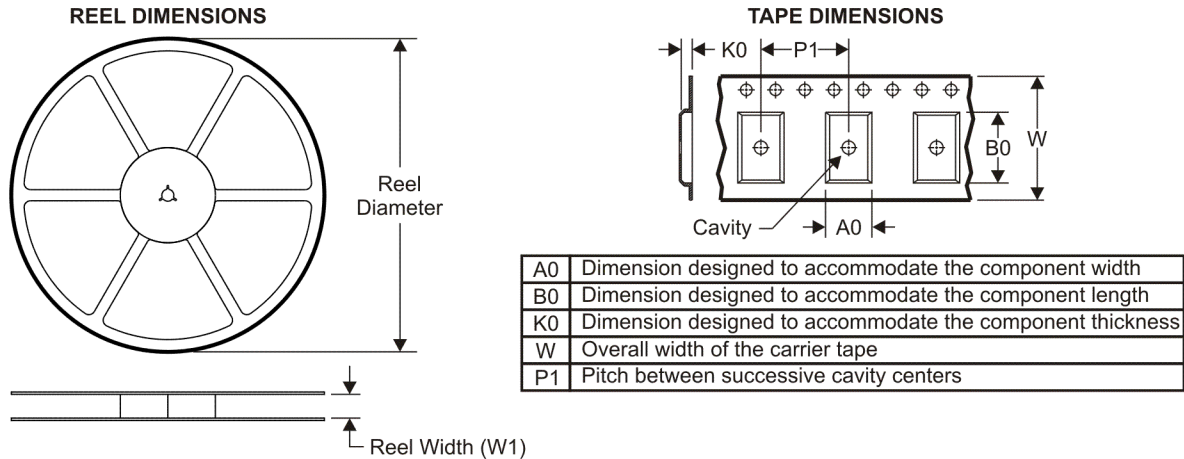

QUADRANT ASSIGNMENTS FOR PIN 1 ORIENTATION IN TAPE



*All dimensions are nominal

Device	Package Type	Package Drawing	Pins	SPQ	Reel Diameter (mm)	Reel Width W1 (mm)	A0 (mm)	B0 (mm)	K0 (mm)	P1 (mm)	W (mm)	Pin1 Quadrant
CDCLVD2106RHAR	VQFN	RHA	40	2500	330.0	16.4	6.3	6.3	1.5	12.0	16.0	Q2
CDCLVD2106RHAT	VQFN	RHA	40	250	330.0	16.4	6.3	6.3	1.5	12.0	16.0	Q2

TAPE AND REEL BOX DIMENSIONS



*All dimensions are nominal

Device	Package Type	Package Drawing	Pins	SPQ	Length (mm)	Width (mm)	Height (mm)
CDCLVD2106RHAR	VQFN	RHA	40	2500	333.2	345.9	28.6
CDCLVD2106RHAT	VQFN	RHA	40	250	333.2	345.9	28.6

RHA (S-PVQFN-N40)

PLASTIC QUAD FLATPACK NO-LEAD

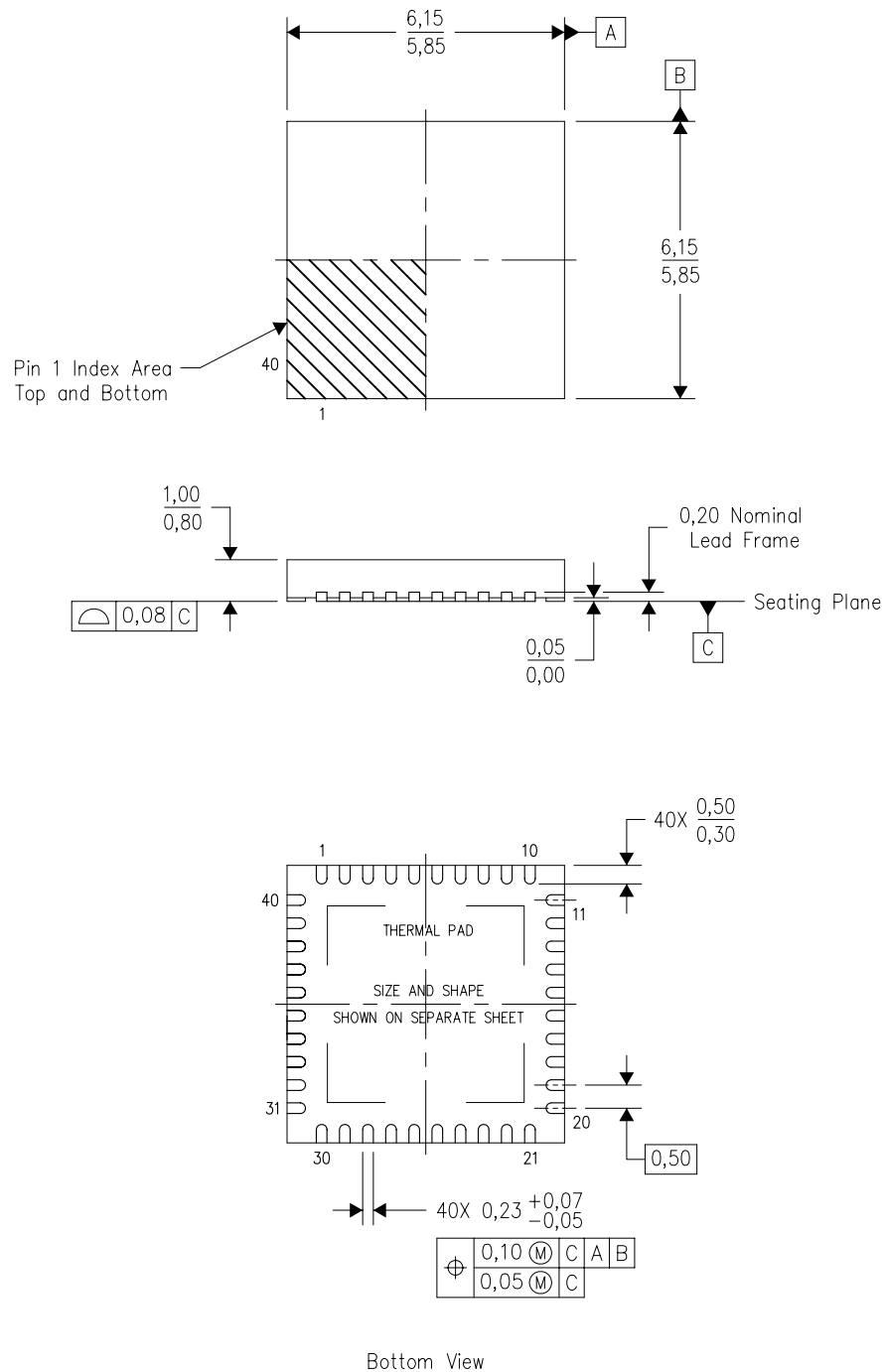

4204276/E 06/11

- NOTES:
- All linear dimensions are in millimeters. Dimensioning and tolerancing per ASME Y14.5M-1994.
 - This drawing is subject to change without notice.
 - QFN (Quad Flatpack No-Lead) Package configuration.
 - The package thermal pad must be soldered to the board for thermal and mechanical performance.
 - See the additional figure in the Product Data Sheet for details regarding the exposed thermal pad features and dimensions.
 - Package complies to JEDEC MO-220 variation VJJD-2.

THERMAL PAD MECHANICAL DATA

RHA (S-PVQFN-N40)

PLASTIC QUAD FLATPACK NO-LEAD

THERMAL INFORMATION

This package incorporates an exposed thermal pad that is designed to be attached directly to an external heatsink. The thermal pad must be soldered directly to the printed circuit board (PCB). After soldering, the PCB can be used as a heatsink. In addition, through the use of thermal vias, the thermal pad can be attached directly to the appropriate copper plane shown in the electrical schematic for the device, or alternatively, can be attached to a special heatsink structure designed into the PCB. This design optimizes the heat transfer from the integrated circuit (IC).

For information on the Quad Flatpack No-Lead (QFN) package and its advantages, refer to Application Report, QFN/SON PCB Attachment, Texas Instruments Literature No. SLUA271. This document is available at www.ti.com.

The exposed thermal pad dimensions for this package are shown in the following illustration.

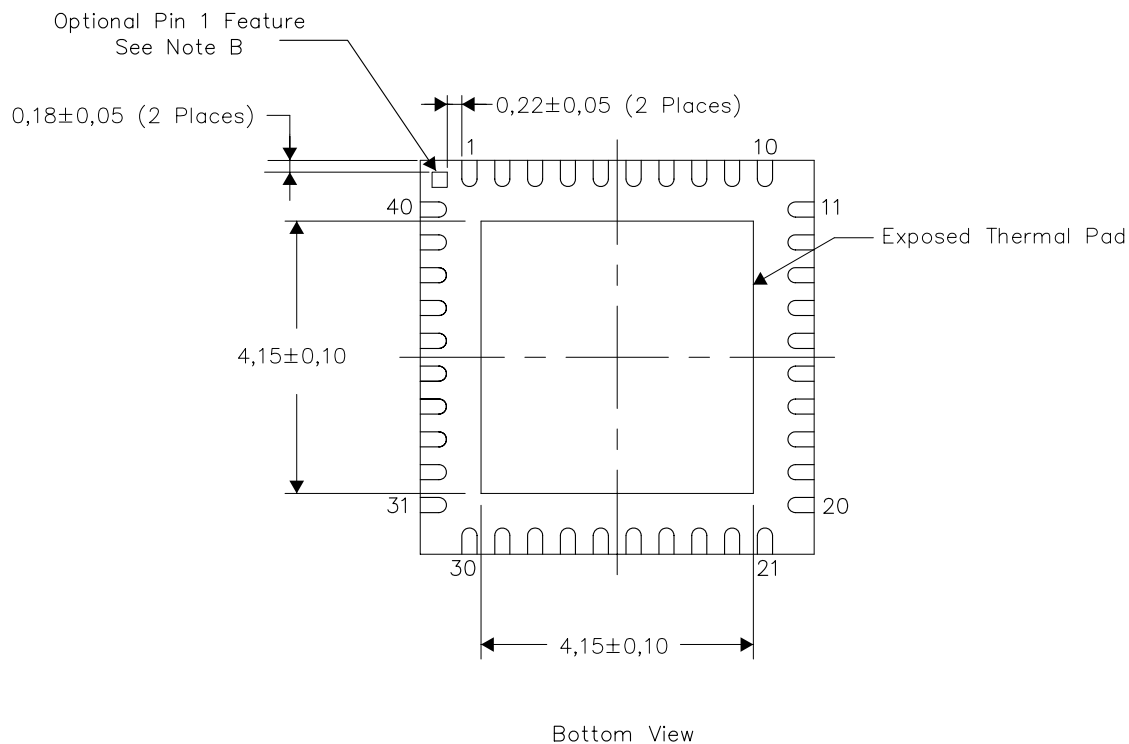

Exposed Thermal Pad Dimensions

4206355-2/0 06/11

- NOTES:
- A. All linear dimensions are in millimeters
 - B. The Pin 1 Identification mark is an optional feature that may be present on some devices
In addition, this Pin 1 feature if present is electrically connected to the center thermal pad and therefore should be considered when routing the board layout.

RHA (S-PVQFN-N40)

PLASTIC QUAD FLATPACK NO-LEAD

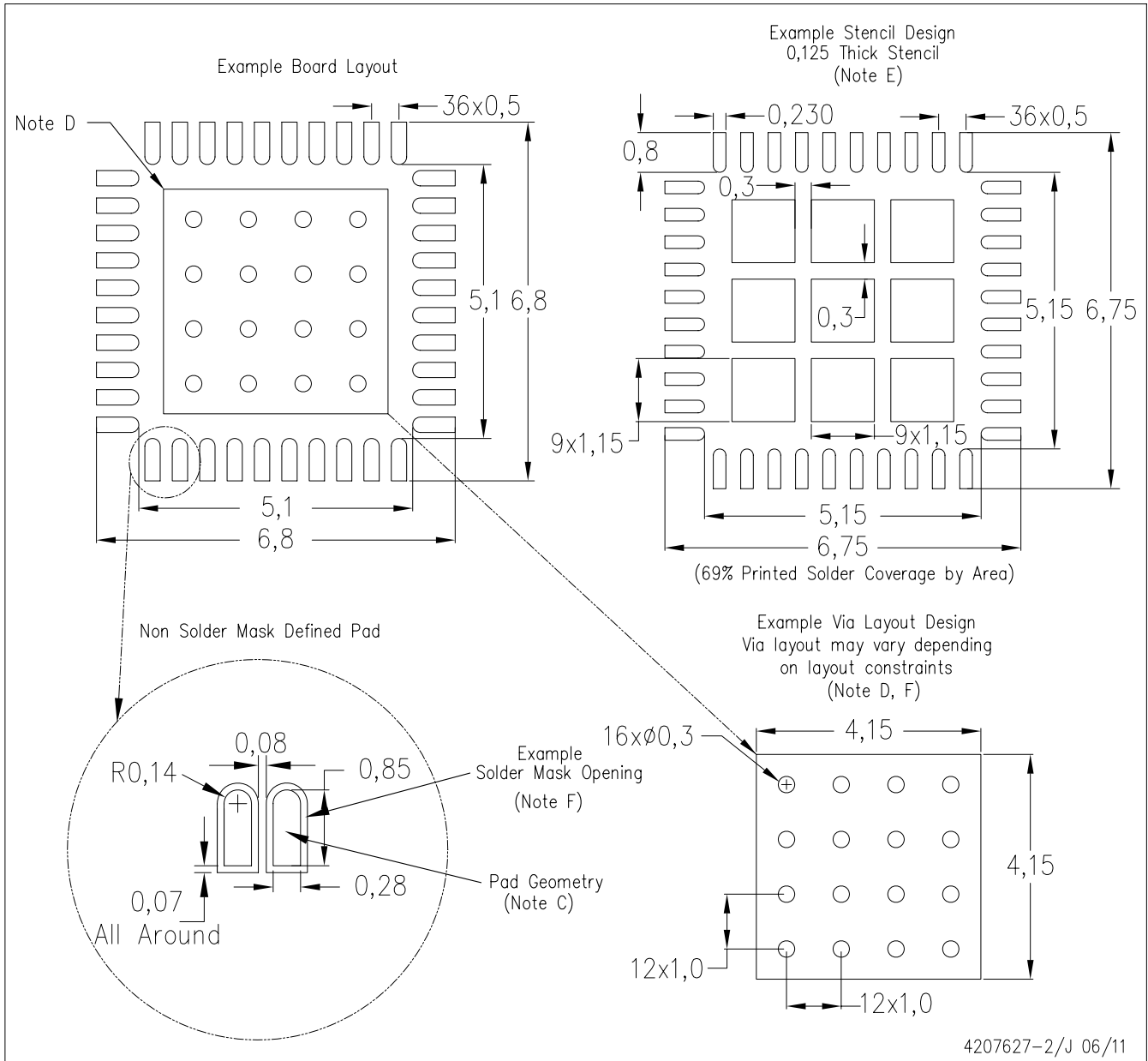

- NOTES:
- A. All linear dimensions are in millimeters.
 - B. This drawing is subject to change without notice.
 - C. Publication IPC-7351 is recommended for alternate designs.
 - D. This package is designed to be soldered to a thermal pad on the board. Refer to Application Note, Quad Flat-Pack Packages, Texas Instruments Literature No. SLUA271, and also the Product Data Sheets for specific thermal information, via requirements, and recommended board layout. These documents are available at www.ti.com <<http://www.ti.com>>.
 - E. Laser cutting apertures with trapezoidal walls and also rounding corners will offer better paste release. Customers should contact their board assembly site for stencil design recommendations. Refer to IPC 7525 for stencil design considerations.
 - F. Customers should contact their board fabrication site for recommended solder mask tolerances and via tenting recommendations for vias placed in the thermal pad.

IMPORTANT NOTICE

Texas Instruments Incorporated and its subsidiaries (TI) reserve the right to make corrections, modifications, enhancements, improvements, and other changes to its products and services at any time and to discontinue any product or service without notice. Customers should obtain the latest relevant information before placing orders and should verify that such information is current and complete. All products are sold subject to TI's terms and conditions of sale supplied at the time of order acknowledgment.

TI warrants performance of its hardware products to the specifications applicable at the time of sale in accordance with TI's standard warranty. Testing and other quality control techniques are used to the extent TI deems necessary to support this warranty. Except where mandated by government requirements, testing of all parameters of each product is not necessarily performed.

TI assumes no liability for applications assistance or customer product design. Customers are responsible for their products and applications using TI components. To minimize the risks associated with customer products and applications, customers should provide adequate design and operating safeguards.

TI does not warrant or represent that any license, either express or implied, is granted under any TI patent right, copyright, mask work right, or other TI intellectual property right relating to any combination, machine, or process in which TI products or services are used. Information published by TI regarding third-party products or services does not constitute a license from TI to use such products or services or a warranty or endorsement thereof. Use of such information may require a license from a third party under the patents or other intellectual property of the third party, or a license from TI under the patents or other intellectual property of TI.

Reproduction of TI information in TI data books or data sheets is permissible only if reproduction is without alteration and is accompanied by all associated warranties, conditions, limitations, and notices. Reproduction of this information with alteration is an unfair and deceptive business practice. TI is not responsible or liable for such altered documentation. Information of third parties may be subject to additional restrictions.

Resale of TI products or services with statements different from or beyond the parameters stated by TI for that product or service voids all express and any implied warranties for the associated TI product or service and is an unfair and deceptive business practice. TI is not responsible or liable for any such statements.

TI products are not authorized for use in safety-critical applications (such as life support) where a failure of the TI product would reasonably be expected to cause severe personal injury or death, unless officers of the parties have executed an agreement specifically governing such use. Buyers represent that they have all necessary expertise in the safety and regulatory ramifications of their applications, and acknowledge and agree that they are solely responsible for all legal, regulatory and safety-related requirements concerning their products and any use of TI products in such safety-critical applications, notwithstanding any applications-related information or support that may be provided by TI. Further, Buyers must fully indemnify TI and its representatives against any damages arising out of the use of TI products in such safety-critical applications.

TI products are neither designed nor intended for use in military/aerospace applications or environments unless the TI products are specifically designated by TI as military-grade or "enhanced plastic." Only products designated by TI as military-grade meet military specifications. Buyers acknowledge and agree that any such use of TI products which TI has not designated as military-grade is solely at the Buyer's risk, and that they are solely responsible for compliance with all legal and regulatory requirements in connection with such use.

TI products are neither designed nor intended for use in automotive applications or environments unless the specific TI products are designated by TI as compliant with ISO/TS 16949 requirements. Buyers acknowledge and agree that, if they use any non-designated products in automotive applications, TI will not be responsible for any failure to meet such requirements.

Following are URLs where you can obtain information on other Texas Instruments products and application solutions:

Products

Audio	www.ti.com/audio
Amplifiers	amplifier.ti.com
Data Converters	dataconverter.ti.com
DLP® Products	www.dlp.com
DSP	dsp.ti.com
Clocks and Timers	www.ti.com/clocks
Interface	interface.ti.com
Logic	logic.ti.com
Power Mgmt	power.ti.com
Microcontrollers	microcontroller.ti.com
RFID	www.ti-rfid.com
RF/IF and ZigBee® Solutions	www.ti.com/lprf

Applications

Communications and Telecom	www.ti.com/communications
Computers and Peripherals	www.ti.com/computers
Consumer Electronics	www.ti.com/consumer-apps
Energy and Lighting	www.ti.com/energy
Industrial	www.ti.com/industrial
Medical	www.ti.com/medical
Security	www.ti.com/security
Space, Avionics and Defense	www.ti.com/space-avionics-defense
Transportation and Automotive	www.ti.com/automotive
Video and Imaging	www.ti.com/video
Wireless	www.ti.com/wireless-apps

TI E2E Community Home Page

e2e.ti.com

Mailing Address: Texas Instruments, Post Office Box 655303, Dallas, Texas 75265
Copyright © 2011, Texas Instruments Incorporated