

PROGRAMMABLE LOW-VOLTAGE 1:10 LVDS CLOCK DRIVER

Check for Samples: [CDCLVD110A](#)

FEATURES

- Low-Output Skew <30 ps (Typical) for Clock-Distribution Applications
- Distributes One Differential Clock Input to 10 LVDS Differential Clock Outputs
- V_{CC} range 2.5 V \pm 5%
- Typical Signaling Rate Capability of Up to 1.1 GHz
- Configurable Register (SI/CK) Individually Enables/Disables Outputs, Selectable CLK0, CLK1 or CLK1, CLK0 Inputs
- Full Rail-to-Rail Common-Mode Input Range
- Receiver Input Threshold \pm 100 mV
- Available in 32-Pin LQFP and QFN Package
- Fail-Safe I/O-Pins for $V_{DD} = 0$ V (Power Down)

APPLICATIONS

- General purpose Industrial, Communication and Consumer Applications

DESCRIPTION

The CDCLVD110A clock driver distributes one pair of differential LVDS clock inputs (either CLK0 or CLK1) to 10 pairs of differential clock outputs (Q0–Q9) with minimum skew for clock distribution. The CDCLVD110A is specifically designed to drive 50- Ω transmission lines.

When the control enable is high (EN = 1), the 10 differential outputs are programmable in that each output can be individually enabled/disabled (3-stated) according to the first 10 bits loaded into the shift register. Once the shift register is loaded, the last bit selects either CLK0 or CLK1 as the clock input. However, when EN = 0, the outputs are not programmable and all outputs are enabled.

The CDCLVD110A has an improved startup circuit that minimizes enabling time in AC- and DC-coupled systems.

The CDCLVD110A is characterized for operation from -40°C to 85°C .

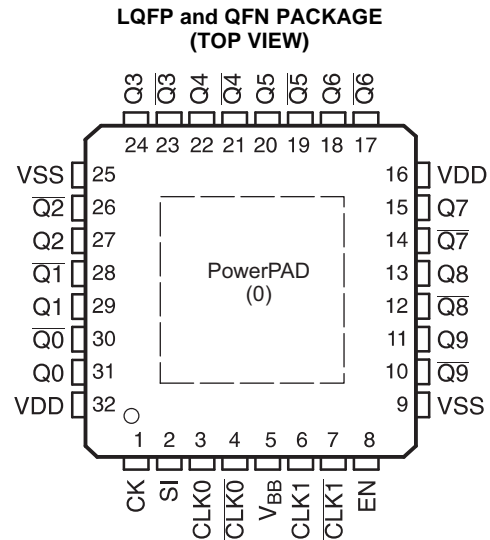

Please be aware that an important notice concerning availability, standard warranty, and use in critical applications of Texas Instruments semiconductor products and disclaimers thereto appears at the end of this data sheet.

PowerPAD is a trademark of Texas Instruments.



This integrated circuit can be damaged by ESD. Texas Instruments recommends that all integrated circuits be handled with appropriate precautions. Failure to observe proper handling and installation procedures can cause damage.

ESD damage can range from subtle performance degradation to complete device failure. Precision integrated circuits may be more susceptible to damage because very small parametric changes could cause the device not to meet its published specifications.

FUNCTIONAL BLOCK DIAGRAM

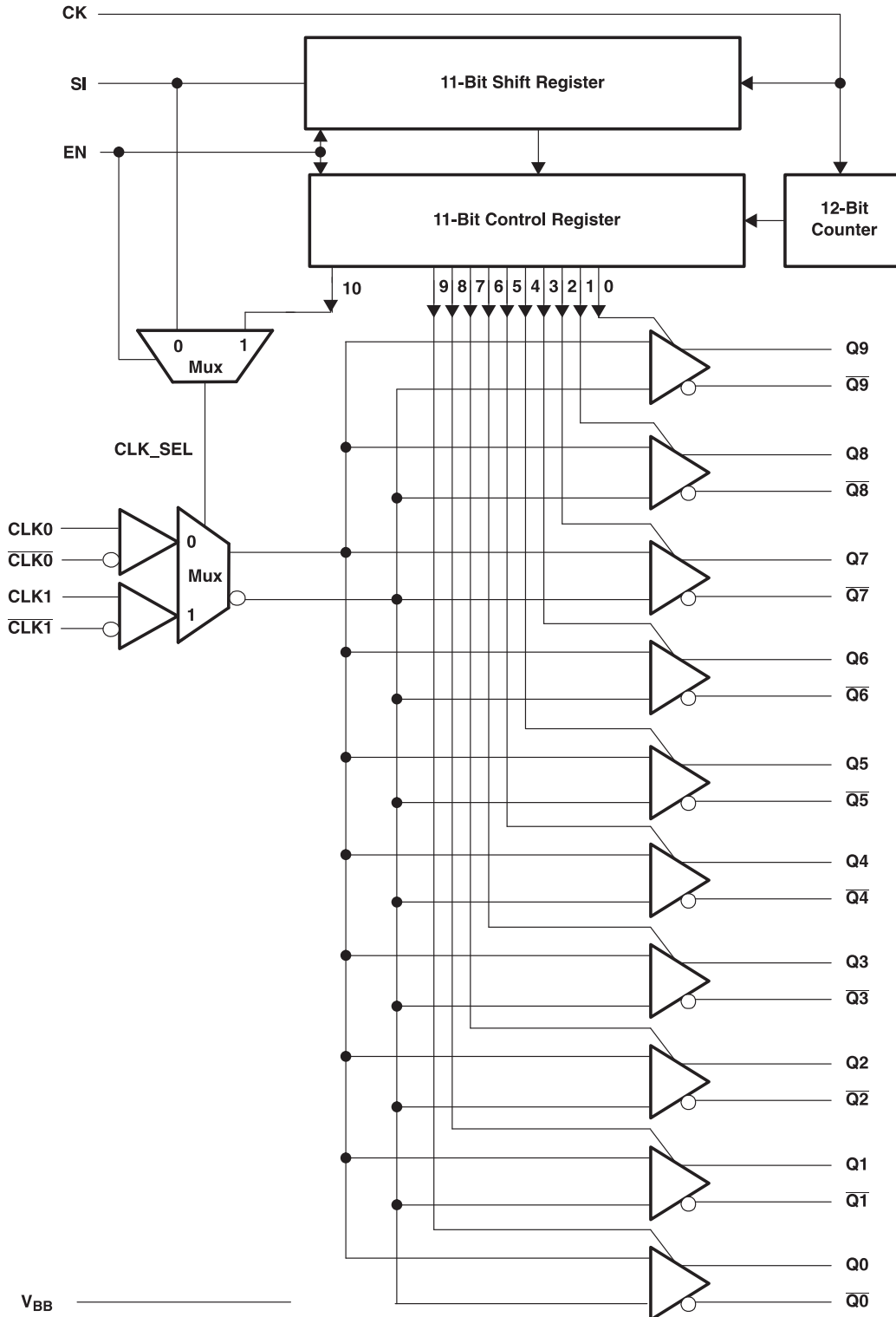

PIN FUNCTIONS

PIN		I/O	DESCRIPTION
NAME	NO.		
CK	1	I	Control register input clock, features a 120-k. pullup resistor
SI	2	I	Control register serial input/CLK Select, features a 120-k. pulldown resistor
CLK0	3	I	True differential input, LVDS
$\overline{\text{CLK0}}$	4	I	Complementary differential input, LVDS
V _{BB}	5	O	Reference voltage output
CLK1	6	I	True differential input, LVDS
$\overline{\text{CLK1}}$	7	I	Complementary differential input, LVDS
EN	8	I	Control enable (for programmability), features a 120-k. pulldown resistor, input
V _{SS}	9, 25		Device ground
V _{DD}	16, 32		Supply voltage
Q [9:0]	11, 13, 15, 18, 20, 22, 24, 27, 29, 31	O	Clock outputs, these outputs provide low-skew copies of CLKIN
$\overline{\text{Q[9:0]}}$	10, 12, 14, 17, 19, 21, 23, 26, 28, 30	O	Complementary clock outputs, these outputs provide low-skew copies of CLKIN
PowerPAD™	0	I/O	The PowerPAD of the QFN32 package is thermally connected to the die to improve the heat transfer out of the package. This pad is connected to GND.

ABSOLUTE MAXIMUM RATINGS⁽¹⁾

		VALUE	UNIT
V _{DD}	Supply voltage	–0.3 to 2.8	V
V _I	Input voltage	–0.2 to (V _{DD} + 0.2)	V
V _O	VI Output voltage	–0.2 to (V _{DD} + 0.2)	V
I _{OSD}	Driver short circuit current, Q _n , $\overline{\text{Qn}}$	Continuous	
ESD	Electrostatic discharge (HBM 1.5 k Ω , 100 pF)	>2000	V

(1) Stresses beyond those listed under *absolute maximum ratings* may cause permanent damage to the device. These are stress ratings only, and functional operation of the device at these or any other conditions beyond those indicated under *recommended operating conditions* is not implied. Exposure to absolute-maximum-rated conditions for extended periods may affect device reliability.

RECOMMENDED OPERATING CONDITIONS

		MIN	NOM	MAX	UNIT
V _{DD}	Supply voltage	2.375	2.5	2.625	V
V _{IC}	Receiver common-mode input voltage	0.5 V _{ID}		V _{DD} – 0.5 V _{ID}	V
T _A	Operating free-air temperature	–40		85	°C

ELECTRICAL CHARACTERISTICS

over recommended operating free-air temperature range (unless otherwise noted)

PARAMETER		TEST CONDITIONS	MIN	TYP	MAX	UNIT
DRIVER						
$ V_{OD} $	Differential output voltage	$R_L = 100\Omega$	250	450	600	mV
ΔV_{OD}	V_{OD} magnitude change				50	mV
V_{OS}	Offset voltage	-40°C to 85°C	0.95	1.2	1.45	V
ΔV_{OS}	V_{OS} magnitude change				350	mV
I_{OS}	Output short circuit current	$V_O = 0\text{ V}$			-20	mA
		$ V_{OD} = 0\text{ V}$			20	
V_{BB}	Reference output voltage	$V_{DD} = 2.5\text{ V}$, $I_{BB} = -100\ \mu\text{A}$	1.15	1.25	1.35	V
C_O	Output capacitance	$V_O = V_{DD}$ or GND		3		pF
RECEIVER						
V_{IDH}	Input threshold high				100	mV
V_{IDL}	Input threshold low		-100			mV
$ V_{ID} $	Input differential voltage		200			mV
I_{IH}	Input current, CLK0/ $\overline{\text{CLK0}}$, CLK1/ $\overline{\text{CLK1}}$	$V_I = V_{DD}$	-5		5	μA
I_{IL}		$V_I = 0\text{ V}$				
C_I	Input capacitance	$V_I = V_{DD}$ or GND		3		pF
SUPPLY CURRENT						
I_{DD}	Supply current	Full loaded	All outputs enabled and loaded, $R_L = 100\ \Omega$, $f = 100\text{ MHz}$	100	110	mA
			All outputs enabled and loaded, $R_L = 100\ \Omega$, $f = 800\text{ MHz}$	150	160	
		No load	Outputs enabled, no output load, $f = 0\text{ Hz}$		35	
I_{DDZ}		3-State	All outputs 3-state by control logic, $f = 0\text{ Hz}$		35	

JITTER CHARACTERISTICS

characterized with CDCLVD110 performance EVM, $V_{DD} = 3.3\text{ V}$, OUTPUTS NOT UNDER TEST are terminated to 50Ω

PARAMETER		TEST CONDITIONS	MIN	TYP	MAX	UNIT
$t_{\text{jitterLVDS}}$	Additive phase jitter from input to LVDS output Q3 and Q3	12 kHz to 5 MHz, $f_{\text{out}} = 30.72\text{ MHz}$		281		fs rms
		12 kHz to 20 MHz, $f_{\text{out}} = 125\text{ MHz}$		111		

LVDS — SWITCHING CHARACTERISTICS

 over recommended operating free-air temperature range, $V_{DD} = 2.5\text{ V} \pm 5\%$

PARAMETER		FROM (INPUT)	TO (OUTPUT)	MIN	TYP	MAX	UNIT
t_{PLH}	Propagation delay low-to-high	CLK0, $\overline{\text{CLK0}}$ CLK1, $\overline{\text{CLK1}}$	Qn, $\overline{\text{Qn}}$		2	3	ns
t_{PHL}	Propagation delay high-to-low	CLK0, $\overline{\text{CLK0}}$ CLK1, $\overline{\text{CLK1}}$	Qn, $\overline{\text{Qn}}$		2	3	ns
t_{duty}	Duty cycle	CLK0, $\overline{\text{CLK0}}$ CLK1, $\overline{\text{CLK1}}$	Qn, $\overline{\text{Qn}}$	45%		55%	
$t_{sk(o)}$	Output skew		Any Qn, $\overline{\text{Qn}}$		30		ps
$t_{sk(p)}$	Pulse skew		Any Qn, $\overline{\text{Qn}}$			50	ps
$t_{sk(pp)}$	Part-to-part skew		Any Qn, $\overline{\text{Qn}}$			600	ps
t_r	Output rise time, 20% to 80%, $R_L = 100\ \Omega$, $C_L = 5\text{ pF}$		Any Qn, $\overline{\text{Qn}}$			350	ps
t_f	Output fall time, 20% to 80%, $R_L = 100\ \Omega$, $C_L = 5\text{ pF}$		Any Qn, $\overline{\text{Qn}}$			350	ps
f_{clk}	Max input frequency	CLK0, $\overline{\text{CLK0}}$ CLK1, $\overline{\text{CLK1}}$	Any Qn, $\overline{\text{Qn}}$	900	1100		MHz

CONTROL REGISTER CHARACTERISTICS

 over recommended operating free-air temperature range, $V_{DD} = 2.5\text{ V} \pm 5\%$ (unless otherwise noted)

PARAMETER		TEST CONDITIONS	MIN	TYP	MAX	UNIT
f_{MAX}	Maximum frequency of shift register		100	150		MHz
t_{su}	Setup time, clock to SI				2	ns
t_h	Hold time, clock to SI				1.5	ns
$t_{removal}$	Removal time, enable to clock				1.5	ns
$t_{startup}$	Startup time after disable through SI				1.0	μs
t_w	Clock pulse width, minimum		3			ns
V_{IH}	Logic input high	$V_{DD} = 2.5\text{ V}$	2			V
V_{IL}	Logic input low	$V_{DD} = 2.5\text{ V}$			0.8	V
I_{IH}	Input current, CK pin	$V_I = V_{DD}$	-5		5	μA
	Input current, SI and EN pins		10		-30	
I_{IL}	Input current, CK pin	$V_I = \text{GND}$	-10		30	μA
	Input current, SI and EN pins		-5		5	

SPECIFICATION OF CONTROL REGISTER

The CDCLVD110A has an 11-bit, serial-in shift register and an 11-bit control register. The control Register enables/disables each output clock, and selects either CLK0 or CLK1 as the input clock. The CDCLVD110A has two modes of operation:

Programmable Mode (EN=1)

The shift register uses a serial input (SI) and a clock input (CK). Once the shift register is loaded with 11 clock pulses, the 12th clock pulse loads the control register. The first bit (bit 0) on SI enables the Q9-Q $\bar{9}$ output pair, and the 10th bit (bit 9) enables the Q0-Q $\bar{0}$ pair. The 11th bit (bit 10) on SI selects either CLK0 or CLK1 as the input clock; a bit value of 0 selects CLK0, whereas a bit value of 1 selects CLK1. To restart the control register configuration, a reset of the state machine must be done with a clock pulse on CK (shift register clock input) and EN set to low. The control register can be configured only once after each reset.

Standard Mode (EN=0)

In this mode, the CDCLVD110A is not programmable and all the clock outputs are enabled. The clock input (CLK0 or CLK1) is selected with the SI pin, as is shown in the table entitled control register.

STATE-MACHINE INPUTS			OUTPUT
EN	SI	CK	
L	L	X	All outputs enabled, CLK0 selected, control register disabled, default state
L	H	X	All outputs enabled, CLK1 selected, control register disabled
H	L	↑	First stage stores L, other stage stores data of previous stage
H	H		First stage stores H, other stage stores data of previous stage
L	X		Reset of state machine, shift and control registers

CONTROL REGISTER		
BIT 10	BITS [0-9]	Q _N [0-9]
L	H	CLK0
H	H	CLK1
X	L	Outputs disabled

SERIAL INPUT (SI) SEQUENCE										
BIT 10	BIT 9	BIT 8	BIT 7	BIT 6	BIT 5	BIT 4	BIT 3	BIT 2	BIT 1	BIT 0
CLK_SEL	Q0	Q1	Q2	Q3	Q4	Q5	Q6	Q7	Q8	Q9

TRUTH TABLE FOR CONTROL LOGIC									
CK	EN	SI	CLK0	$\overline{\text{CLK0}}$	CLK1	$\overline{\text{CLK1}}$	Q(0-9)	$\overline{\text{Q(0-9)}}$	
L	L	L	L	H	X	X	L	H	
L	L	L	H	L	X	X	H	L	
L	L	L	Open	Open	X	X	L	H	
L	L	H	X	X	L	H	L	H	
L	L	H	X	X	H	L	H	L	
L	L	H	X	X	Open	Open	L	H	
All outputs enabled			X = Don't care						

APPLICATION INFORMATION

Fall-Safe Information

For $V_{DD} = 0$ V (power-down mode) the CDCLVD110A has fail-safe input and output pins. In power-on mode, fail-safe biasing at input pins can be accomplished with a 10-k Ω pullup resistor from CLK0/CLK1 to VDD and a 10-k Ω pulldown resistor from CLK0/CLK1 to GND.

LVDS Receiver Input Termination

The LVDS receiver inputs require 100- Ω termination resistors placed as close as possible across the input pins.

Control Inputs Termination

No external termination is required. The CK control input has an internal 120-k Ω pullup resistor, while the SI- and EN-control inputs each have an internal 120-k Ω pulldown resistor. If the control pins are left open per the default, all outputs are enabled, CLK0, CLK0 is selected, and the control register is disabled.

PARAMETER MEASUREMENT INFORMATION

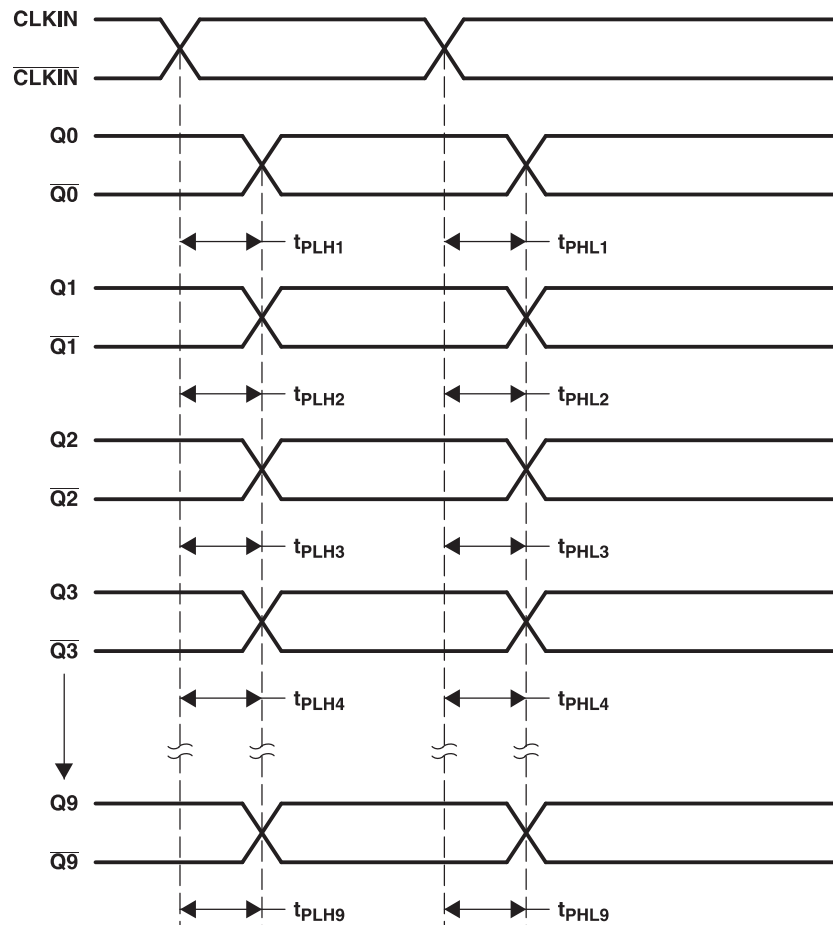

- A. Output skew, $t_{sk(o)}$, is calculated as the greater of:
 - The difference between the fastest and the slowest t_{PLHn} ($n = 1, 2, \dots, 10$)
 - The difference between the fastest and the slowest t_{PHLn} ($n = 1, 2, \dots, 10$)
- B. Part-to-part skew, $t_{sk(pp)}$, is calculated as the greater of:
 - The difference between the fastest and the slowest t_{PLHn} ($n = 1, 2, \dots, 10$) across multiple devices
 - The difference between the fastest and the slowest t_{PHLn} ($n = 1, 2, \dots, 10$) across multiple devices
- C. Pulse skew, $t_{sk(p)}$, is calculated as the magnitude of the absolute time difference between the high-to-low (t_{PHL}) and the low-to-high (t_{PLH}) propagation delays when a single switching input causes one or more outputs to switch, $t_{sk(p)} = |t_{PHL} - t_{PLH}|$. Pulse skew is sometimes referred to as pulse-width distortion or duty-cycle skew.

Figure 1. Waveforms for Calculation of $t_{sk(o)}$ and $t_{sk(pp)}$

PARAMETER MEASUREMENT INFORMATION (continued)

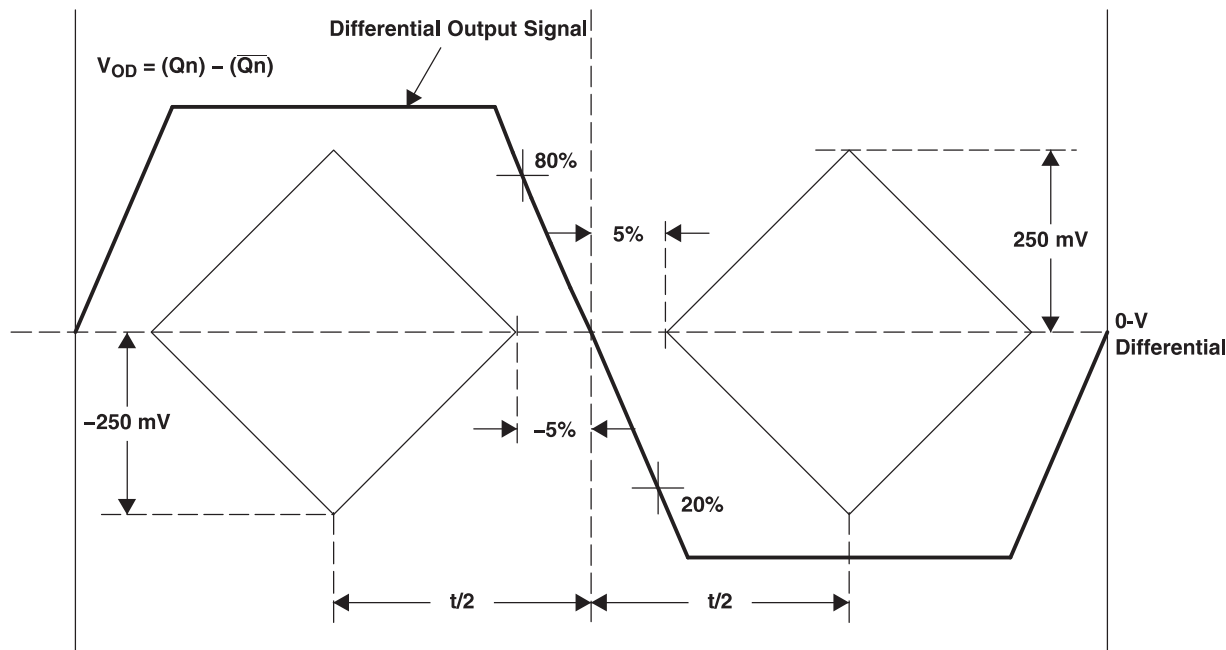

Figure 2. Test Criteria for f_{clk} , Duty Cycle, t_r , t_f , V_{OD}

REVISION HISTORY

Changes from Original (February 2007) to Revision A	Page
<ul style="list-style-type: none"> Changed Pinout Package title From: TQFP PACKAGE and QFN PACKAGE To: LQFP PACKAGE and QFN PACKAGE 1 	1
Changes from Revision A (January 2008) to Revision B	Page
<ul style="list-style-type: none"> Changed Feature From: Available in 32-Pin LQFP Package To: Available in 32-Pin LQFP and QFN Package 1 Added Applications 1 	1
Changes from Revision B (October 2008) to Revision C	Page
<ul style="list-style-type: none"> Added PowerPAD information to the Pinout Package 1 Added PowerPAD information to the Pin FUNCTIONS table 3 	1

PACKAGING INFORMATION

Orderable Device	Status ⁽¹⁾	Package Type	Package Drawing	Pins	Package Qty	Eco Plan ⁽²⁾	Lead/ Ball Finish	MSL Peak Temp ⁽³⁾	Samples (Requires Login)
CDCLVD110ARHBR	ACTIVE	QFN	RHB	32	3000	Green (RoHS & no Sb/Br)	CU NIPDAU	Level-2-260C-1 YEAR	
CDCLVD110ARHBRG4	ACTIVE	QFN	RHB	32	3000	Green (RoHS & no Sb/Br)	CU NIPDAU	Level-2-260C-1 YEAR	
CDCLVD110ARHBT	ACTIVE	QFN	RHB	32	250	Green (RoHS & no Sb/Br)	CU NIPDAU	Level-2-260C-1 YEAR	
CDCLVD110ARHBTG4	ACTIVE	QFN	RHB	32	250	Green (RoHS & no Sb/Br)	CU NIPDAU	Level-2-260C-1 YEAR	
CDCLVD110AVF	ACTIVE	LQFP	VF	32	250	Green (RoHS & no Sb/Br)	CU NIPDAU	Level-1-260C-UNLIM	
CDCLVD110AVFG4	ACTIVE	LQFP	VF	32	250	Green (RoHS & no Sb/Br)	CU NIPDAU	Level-1-260C-UNLIM	
CDCLVD110AVFR	ACTIVE	LQFP	VF	32	1000	Green (RoHS & no Sb/Br)	CU NIPDAU	Level-1-260C-UNLIM	
CDCLVD110AVFRG4	ACTIVE	LQFP	VF	32	1000	Green (RoHS & no Sb/Br)	CU NIPDAU	Level-1-260C-UNLIM	

⁽¹⁾ The marketing status values are defined as follows:

ACTIVE: Product device recommended for new designs.

LIFEBUY: TI has announced that the device will be discontinued, and a lifetime-buy period is in effect.

NRND: Not recommended for new designs. Device is in production to support existing customers, but TI does not recommend using this part in a new design.

PREVIEW: Device has been announced but is not in production. Samples may or may not be available.

OBSOLETE: TI has discontinued the production of the device.

⁽²⁾ Eco Plan - The planned eco-friendly classification: Pb-Free (RoHS), Pb-Free (RoHS Exempt), or Green (RoHS & no Sb/Br) - please check <http://www.ti.com/productcontent> for the latest availability information and additional product content details.

TBD: The Pb-Free/Green conversion plan has not been defined.

Pb-Free (RoHS): TI's terms "Lead-Free" or "Pb-Free" mean semiconductor products that are compatible with the current RoHS requirements for all 6 substances, including the requirement that lead not exceed 0.1% by weight in homogeneous materials. Where designed to be soldered at high temperatures, TI Pb-Free products are suitable for use in specified lead-free processes.

Pb-Free (RoHS Exempt): This component has a RoHS exemption for either 1) lead-based flip-chip solder bumps used between the die and package, or 2) lead-based die adhesive used between the die and leadframe. The component is otherwise considered Pb-Free (RoHS compatible) as defined above.

Green (RoHS & no Sb/Br): TI defines "Green" to mean Pb-Free (RoHS compatible), and free of Bromine (Br) and Antimony (Sb) based flame retardants (Br or Sb do not exceed 0.1% by weight in homogeneous material)

⁽³⁾ MSL, Peak Temp. -- The Moisture Sensitivity Level rating according to the JEDEC industry standard classifications, and peak solder temperature.

Important Information and Disclaimer: The information provided on this page represents TI's knowledge and belief as of the date that it is provided. TI bases its knowledge and belief on information provided by third parties, and makes no representation or warranty as to the accuracy of such information. Efforts are underway to better integrate information from third parties. TI has taken and continues to take reasonable steps to provide representative and accurate information but may not have conducted destructive testing or chemical analysis on incoming materials and chemicals. TI and TI suppliers consider certain information to be proprietary, and thus CAS numbers and other limited information may not be available for release.

In no event shall TI's liability arising out of such information exceed the total purchase price of the TI part(s) at issue in this document sold by TI to Customer on an annual basis.

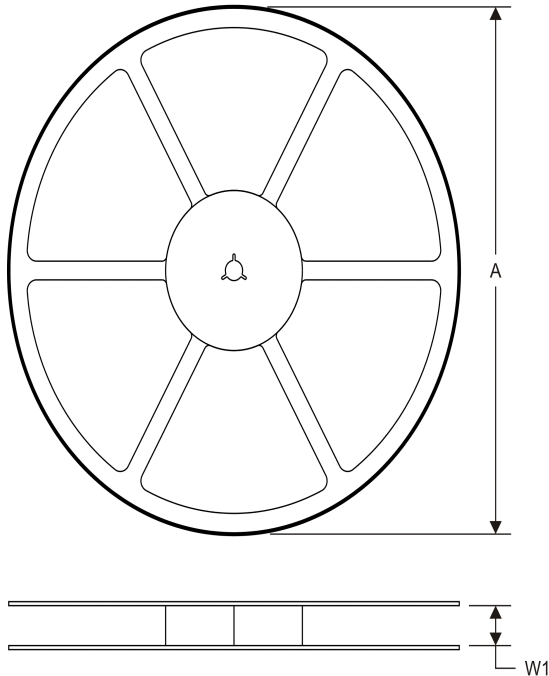
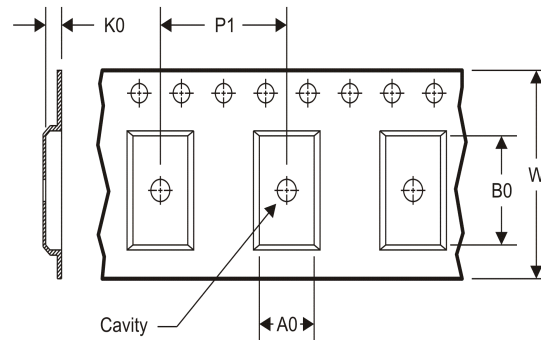
TAPE AND REEL INFORMATION
REEL DIMENSIONS

TAPE DIMENSIONS

A0	Dimension designed to accommodate the component width
B0	Dimension designed to accommodate the component length
K0	Dimension designed to accommodate the component thickness
W	Overall width of the carrier tape
P1	Pitch between successive cavity centers

TAPE AND REEL INFORMATION

*All dimensions are nominal

Device	Package Type	Package Drawing	Pins	SPQ	Reel Diameter (mm)	Reel Width W1 (mm)	A0 (mm)	B0 (mm)	K0 (mm)	P1 (mm)	W (mm)	Pin1 Quadrant
CDCLVD110ARHBR	QFN	RHB	32	3000	330.0	12.4	5.3	5.3	1.5	8.0	12.0	Q2
CDCLVD110ARHBT	QFN	RHB	32	250	330.0	12.4	5.3	5.3	1.5	8.0	12.0	Q2
CDCLVD110AVFR	LQFP	VF	32	1000	330.0	16.4	9.6	9.6	1.9	12.0	16.0	Q2

TAPE AND REEL BOX DIMENSIONS



*All dimensions are nominal

Device	Package Type	Package Drawing	Pins	SPQ	Length (mm)	Width (mm)	Height (mm)
CDCLVD110ARHBR	QFN	RHB	32	3000	338.1	338.1	20.6
CDCLVD110ARHBT	QFN	RHB	32	250	338.1	338.1	20.6
CDCLVD110AVFR	LQFP	VF	32	1000	341.0	159.0	123.5

RHB (S-PVQFN-N32)

PLASTIC QUAD FLATPACK NO-LEAD

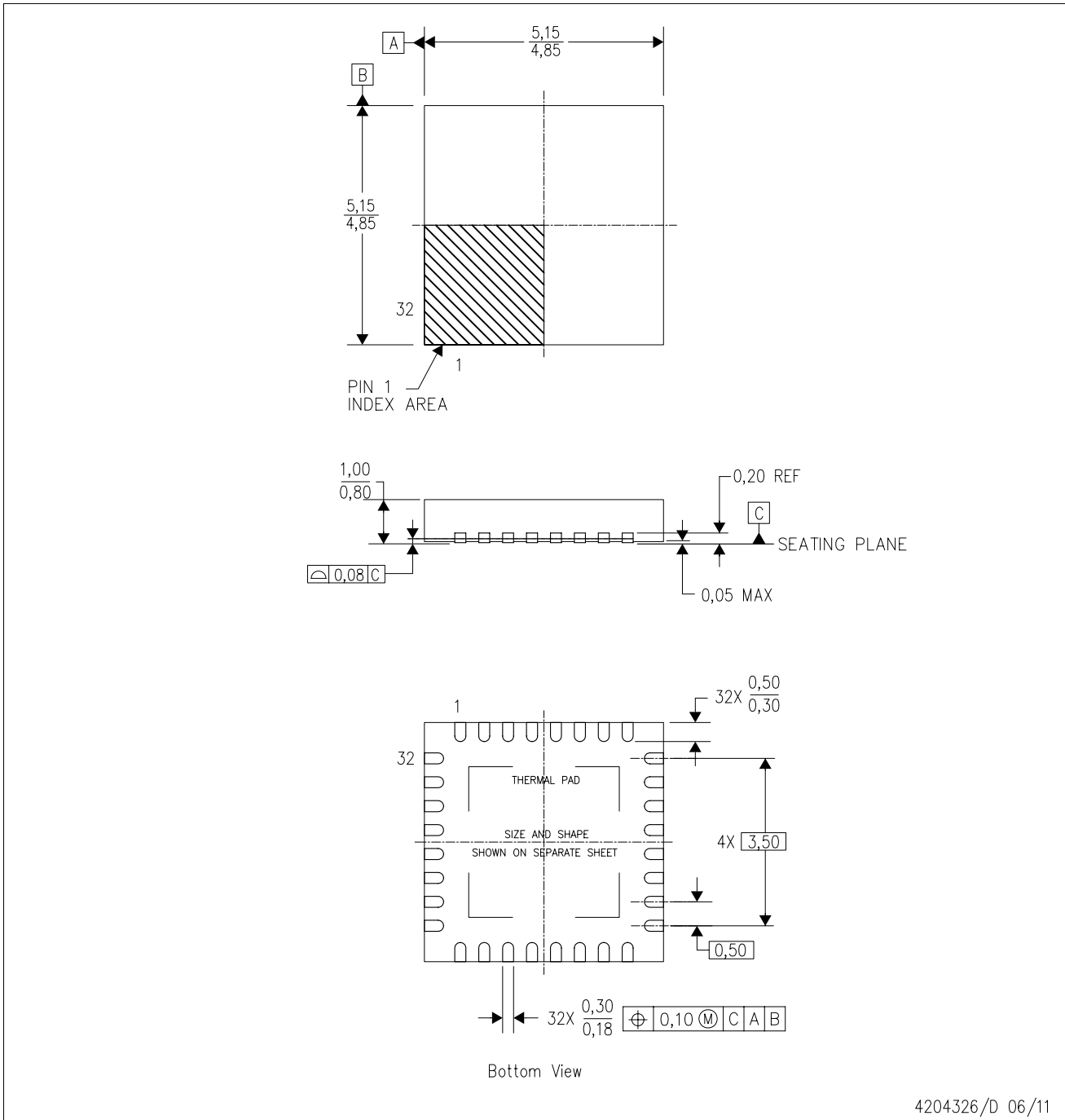

- NOTES:
- All linear dimensions are in millimeters. Dimensioning and tolerancing per ASME Y14.5M-1994.
 - This drawing is subject to change without notice.
 - QFN (Quad Flatpack No-Lead) Package configuration.
 - The package thermal pad must be soldered to the board for thermal and mechanical performance.
 - See the additional figure in the Product Data Sheet for details regarding the exposed thermal pad features and dimensions.
 - Falls within JEDEC MO-220.

THERMAL PAD MECHANICAL DATA

RHB (S-PVQFN-N32)

PLASTIC QUAD FLATPACK NO-LEAD

THERMAL INFORMATION

This package incorporates an exposed thermal pad that is designed to be attached directly to an external heatsink. The thermal pad must be soldered directly to the printed circuit board (PCB). After soldering, the PCB can be used as a heatsink. In addition, through the use of thermal vias, the thermal pad can be attached directly to the appropriate copper plane shown in the electrical schematic for the device, or alternatively, can be attached to a special heatsink structure designed into the PCB. This design optimizes the heat transfer from the integrated circuit (IC).

For information on the Quad Flatpack No-Lead (QFN) package and its advantages, refer to Application Report, QFN/SON PCB Attachment, Texas Instruments Literature No. SLUA271. This document is available at www.ti.com.

The exposed thermal pad dimensions for this package are shown in the following illustration.

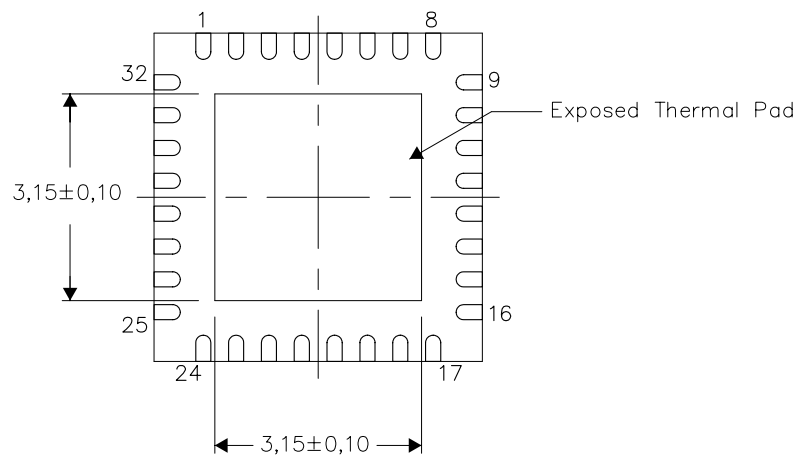

Bottom View

Exposed Thermal Pad Dimensions

4206356-3/U 06/11

NOTE: A. All linear dimensions are in millimeters

RHB (S-PVQFN-N32)

PLASTIC QUAD FLATPACK NO-LEAD

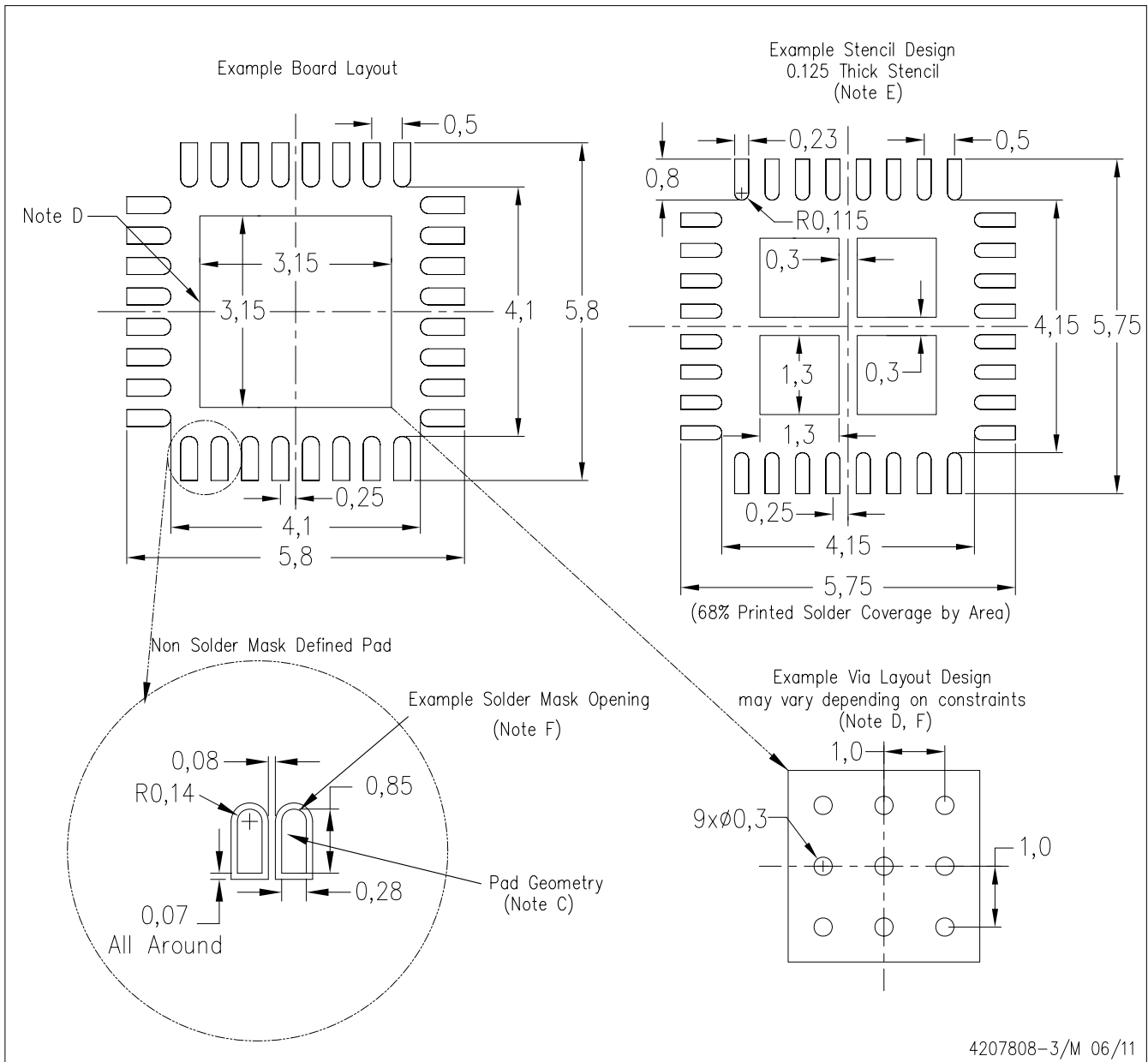

- NOTES:
- A. All linear dimensions are in millimeters.
 - B. This drawing is subject to change without notice.
 - C. Publication IPC-7351 is recommended for alternate designs.
 - D. This package is designed to be soldered to a thermal pad on the board. Refer to Application Note, Quad Flat-Pack Packages, Texas Instruments Literature No. SLUA271, and also the Product Data Sheets for specific thermal information, via requirements, and recommended board layout. These documents are available at www.ti.com <<http://www.ti.com>>.
 - E. Laser cutting apertures with trapezoidal walls and also rounding corners will offer better paste release. Customers should contact their board assembly site for stencil design recommendations. Refer to IPC 7525 for stencil design considerations.
 - F. Customers should contact their board fabrication site for recommended solder mask tolerances and via tenting recommendations for vias placed in the thermal pad.

VF (S-PQFP-G32)

PLASTIC QUAD FLATPACK

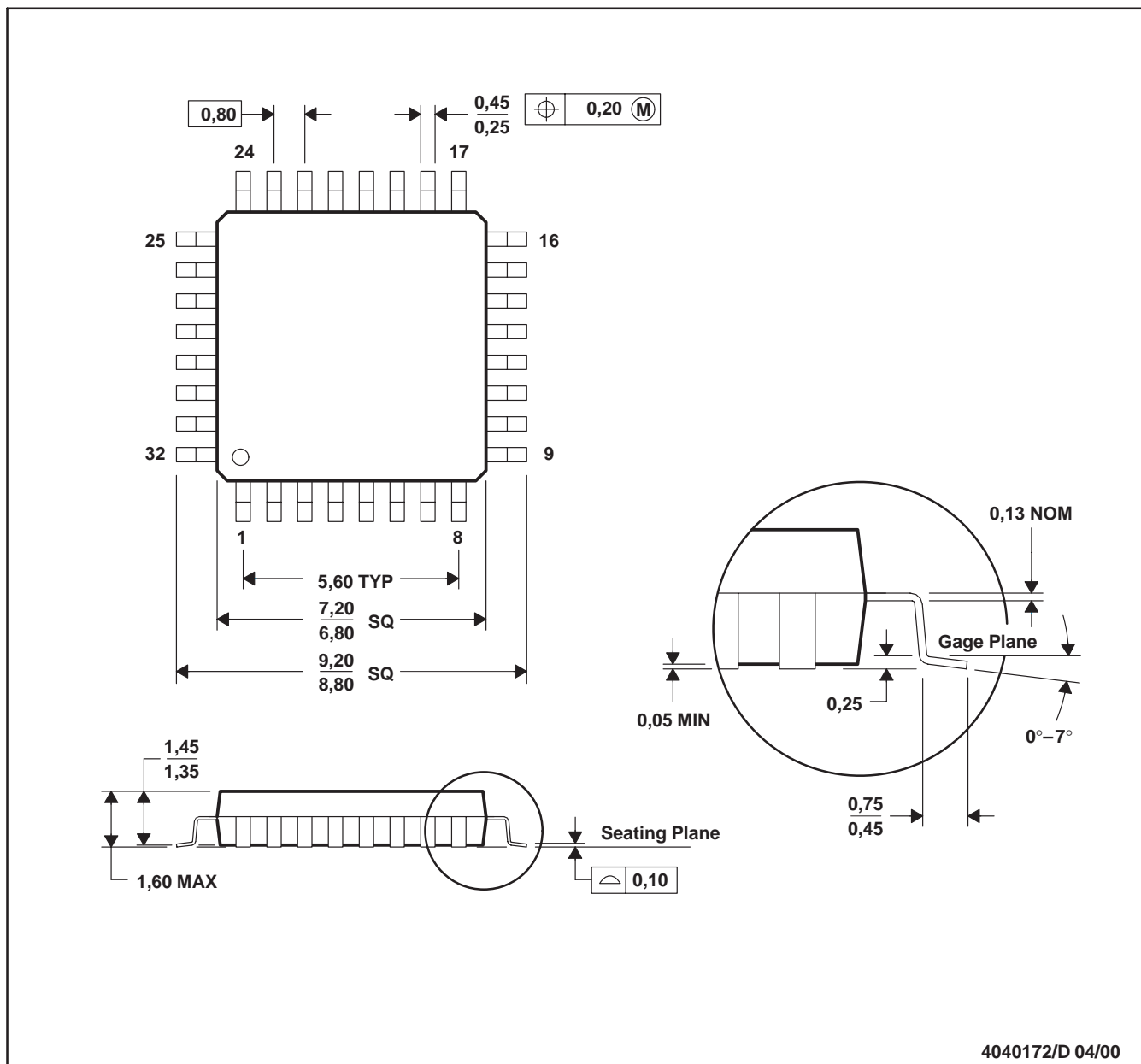

NOTES: A. All linear dimensions are in millimeters.
 B. This drawing is subject to change without notice.

IMPORTANT NOTICE

Texas Instruments Incorporated and its subsidiaries (TI) reserve the right to make corrections, modifications, enhancements, improvements, and other changes to its products and services at any time and to discontinue any product or service without notice. Customers should obtain the latest relevant information before placing orders and should verify that such information is current and complete. All products are sold subject to TI's terms and conditions of sale supplied at the time of order acknowledgment.

TI warrants performance of its hardware products to the specifications applicable at the time of sale in accordance with TI's standard warranty. Testing and other quality control techniques are used to the extent TI deems necessary to support this warranty. Except where mandated by government requirements, testing of all parameters of each product is not necessarily performed.

TI assumes no liability for applications assistance or customer product design. Customers are responsible for their products and applications using TI components. To minimize the risks associated with customer products and applications, customers should provide adequate design and operating safeguards.

TI does not warrant or represent that any license, either express or implied, is granted under any TI patent right, copyright, mask work right, or other TI intellectual property right relating to any combination, machine, or process in which TI products or services are used. Information published by TI regarding third-party products or services does not constitute a license from TI to use such products or services or a warranty or endorsement thereof. Use of such information may require a license from a third party under the patents or other intellectual property of the third party, or a license from TI under the patents or other intellectual property of TI.

Reproduction of TI information in TI data books or data sheets is permissible only if reproduction is without alteration and is accompanied by all associated warranties, conditions, limitations, and notices. Reproduction of this information with alteration is an unfair and deceptive business practice. TI is not responsible or liable for such altered documentation. Information of third parties may be subject to additional restrictions.

Resale of TI products or services with statements different from or beyond the parameters stated by TI for that product or service voids all express and any implied warranties for the associated TI product or service and is an unfair and deceptive business practice. TI is not responsible or liable for any such statements.

TI products are not authorized for use in safety-critical applications (such as life support) where a failure of the TI product would reasonably be expected to cause severe personal injury or death, unless officers of the parties have executed an agreement specifically governing such use. Buyers represent that they have all necessary expertise in the safety and regulatory ramifications of their applications, and acknowledge and agree that they are solely responsible for all legal, regulatory and safety-related requirements concerning their products and any use of TI products in such safety-critical applications, notwithstanding any applications-related information or support that may be provided by TI. Further, Buyers must fully indemnify TI and its representatives against any damages arising out of the use of TI products in such safety-critical applications.

TI products are neither designed nor intended for use in military/aerospace applications or environments unless the TI products are specifically designated by TI as military-grade or "enhanced plastic." Only products designated by TI as military-grade meet military specifications. Buyers acknowledge and agree that any such use of TI products which TI has not designated as military-grade is solely at the Buyer's risk, and that they are solely responsible for compliance with all legal and regulatory requirements in connection with such use.

TI products are neither designed nor intended for use in automotive applications or environments unless the specific TI products are designated by TI as compliant with ISO/TS 16949 requirements. Buyers acknowledge and agree that, if they use any non-designated products in automotive applications, TI will not be responsible for any failure to meet such requirements.

Following are URLs where you can obtain information on other Texas Instruments products and application solutions:

Products

Audio	www.ti.com/audio
Amplifiers	amplifier.ti.com
Data Converters	dataconverter.ti.com
DLP® Products	www.dlp.com
DSP	dsp.ti.com
Clocks and Timers	www.ti.com/clocks
Interface	interface.ti.com
Logic	logic.ti.com
Power Mgmt	power.ti.com
Microcontrollers	microcontroller.ti.com
RFID	www.ti-rfid.com
OMAP Mobile Processors	www.ti.com/omap
Wireless Connectivity	www.ti.com/wirelessconnectivity

Applications

Automotive and Transportation	www.ti.com/automotive
Communications and Telecom	www.ti.com/communications
Computers and Peripherals	www.ti.com/computers
Consumer Electronics	www.ti.com/consumer-apps
Energy and Lighting	www.ti.com/energy
Industrial	www.ti.com/industrial
Medical	www.ti.com/medical
Security	www.ti.com/security
Space, Avionics and Defense	www.ti.com/space-avionics-defense
Video and Imaging	www.ti.com/video

TI E2E Community Home Page

e2e.ti.com

Mailing Address: Texas Instruments, Post Office Box 655303, Dallas, Texas 75265
Copyright © 2012, Texas Instruments Incorporated