

- **Designed to Meet PC133 SDRAM Registered DIMM Specification Rev. 0.9**
- **Spread Spectrum Clock Compatible**
- **Operating Frequency 25 MHz to 140 MHz**
- **Static Phase Error Distribution at 66 MHz to 133 MHz is ± 125 ps**
- **Jitter (cyc–cyc) at 66 MHz to 133 MHz is $|70|$ ps**
- **Available in Plastic 24-Pin TSSOP**
- **Phase-Lock Loop Clock Distribution for Synchronous DRAM Applications**
- **Distributes One Clock Input to One Bank of Five and One Bank of Four Outputs**
- **Separate Output Enable for Each Output Bank**
- **External Feedback (FBIN) Terminal Is Used to Synchronize the Outputs to the Clock Input**
- **On-Chip Series Damping Resistors**
- **No External RC Network Required**
- **Operates at 3.3 V**

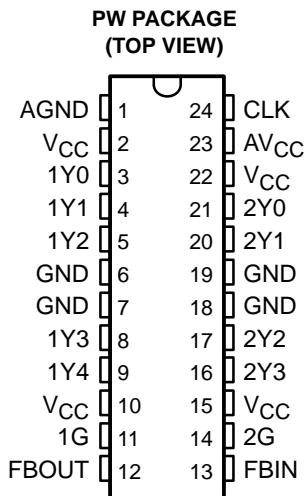

description

The CDCF2509 is a high-performance, low-skew, low-jitter, phase-lock loop (PLL) clock driver. It uses a PLL to precisely align, in both frequency and phase, the feedback (FBOUT) output to the clock (CLK) input signal. It is specifically designed for use with synchronous DRAMs. The CDCF2509 operates at 3.3 V V_{CC} . It also provides integrated series-damping resistors that make it ideal for driving point-to-point loads.

One bank of five outputs and one bank of four outputs provide nine low-skew, low-jitter copies of CLK. Output signal duty cycles are adjusted to 50%, independent of the duty cycle at CLK. Each bank of outputs is enabled or disabled separately via the control (1G and 2G) inputs. When the G inputs are high, the outputs switch in phase and frequency with CLK; when the G inputs are low, the outputs are disabled to the logic-low state.

Unlike many products containing PLLs, the CDCF2509 does not require external RC networks. The loop filter for the PLL is included on-chip, minimizing component count, board space, and cost.

Because it is based on PLL circuitry, the CDCF2509 requires a stabilization time to achieve phase lock of the feedback signal to the reference signal. This stabilization time is required following power up and application of a fixed-frequency, fixed-phase signal at CLK, and following any changes to the PLL reference or feedback signals. The PLL can be bypassed for test purposes by strapping AV_{CC} to ground.

The CDCF2509 is characterized for operation from 0°C to 85°C.

For application information refer to application reports *High Speed Distribution Design Techniques for CDC509/516/2509/2510/2516* (literature number SLMA003) and *Using CDC2509A/2510A PLL with Spread Spectrum Clocking (SSC)* (literature number SCAA039).



Please be aware that an important notice concerning availability, standard warranty, and use in critical applications of Texas Instruments semiconductor products and disclaimers thereto appears at the end of this data sheet.

CDCF2509

3.3-V PHASE-LOCK LOOP CLOCK DRIVER

SCAS624B – APRIL 1999 – REVISED MARCH 2001

FUNCTION TABLE

INPUTS			OUTPUTS		
1G	2G	CLK	1Y (0:4)	2Y (0:3)	FBOUT
X	X	L	L	L	L
L	L	H	L	L	H
L	H	H	L	H	H
H	L	H	H	L	H
H	H	H	H	H	H

functional block diagram

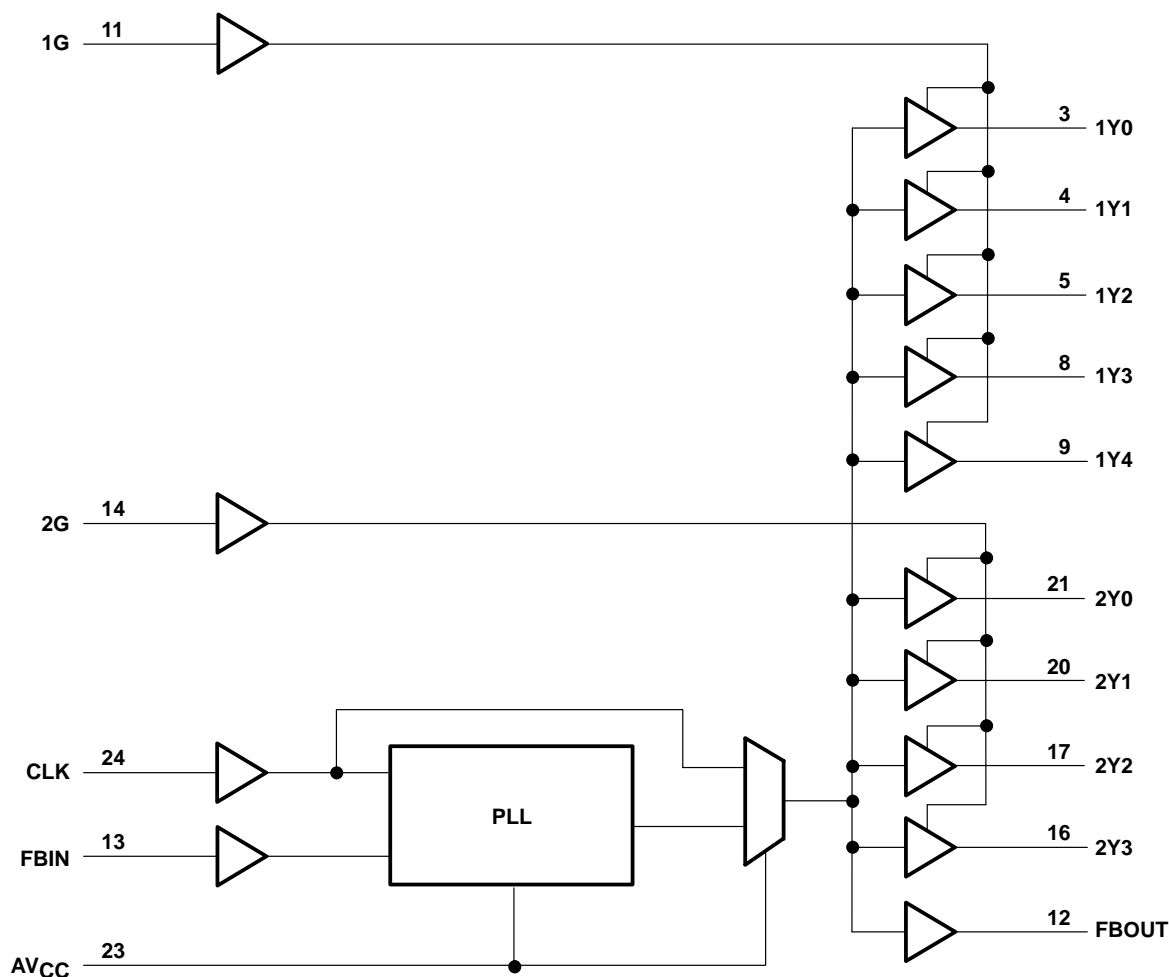

AVAILABLE OPTIONS

T _A	PACKAGE
	SMALL OUTLINE (PW)
0°C to 85°C	CDCF2509PWR



POST OFFICE BOX 655303 • DALLAS, TEXAS 75265

CDCF2509

3.3-V PHASE-LOCK LOOP CLOCK DRIVER

SCAS624B – APRIL 1999 – REVISED MARCH 2001

Terminal Functions

TERMINAL NAME	NO.	TYPE	DESCRIPTION
CLK	24	I	Clock input. CLK provides the clock signal to be distributed by the CDCF2509 clock driver. CLK is used to provide the reference signal to the integrated PLL that generates the clock output signals. CLK must have a fixed frequency and fixed phase for the PLL to obtain phase lock. Once the circuit is powered up and a valid CLK signal is applied, a stabilization time is required for the PLL to phase lock the feedback signal to its reference signal.
FBIN	13	I	Feedback input. FBIN provides the feedback signal to the internal PLL. FBIN must be hard-wired to FBOUT to complete the PLL. The integrated PLL synchronizes CLK and FBIN so that there is nominally zero phase error between CLK and FBIN.
1G	11	I	Output bank enable. 1G is the output enable for outputs 1Y(0:4). When 1G is low, outputs 1Y(0:4) are disabled to a logic-low state. When 1G is high, all outputs 1Y(0:4) are enabled and switched at the same frequency as CLK.
2G	14	I	Output bank enable. 2G is the output enable for outputs 2Y(0:3). When 2G is low, outputs 2Y(0:3) are disabled to a logic-low state. When 2G is high, all outputs 2Y(0:3) are enabled and switch at the same frequency as CLK.
FBOUT	12	O	Feedback output. FBOUT is dedicated for external feedback. It switches at the same frequency as CLK. When externally wired to FBIN, FBOUT completes the feedback loop of the PLL. FBOUT has an integrated 25- Ω series-damping resistor.
1Y (0:4)	3, 4, 5, 8, 9	O	Clock outputs. These outputs provide low-skew copies of CLK. Output bank 1Y(0:4) is enabled via the 1G input. These outputs can be disabled to a logic-low state by deasserting the 1G control input. Each output has an integrated 25- Ω series-damping resistor.
2Y (0:3)	21, 20, 17, 16	O	Clock outputs. These outputs provide low-skew copies of CLK. Output bank 2Y(0:3) is enabled via the 2G input. These outputs can be disabled to a logic-low state by deasserting the 2G control input. Each output has an integrated 25- Ω series-damping resistor.
AV _{CC}	23	Power	Analog power supply. AV _{CC} provides the power reference for the analog circuitry. In addition, AV _{CC} can be used to bypass the PLL for test purposes. When AV _{CC} is strapped to ground, PLL is bypassed and CLK is buffered directly to the device outputs.
AGND	1	Ground	Analog ground. AGND provides the ground reference for the analog circuitry.
V _{CC}	2, 10, 15, 22	Power	Power supply
GND	6, 7, 18, 19	Ground	Ground

CDCF2509

3.3-V PHASE-LOCK LOOP CLOCK DRIVER

SCAS624B – APRIL 1999 – REVISED MARCH 2001

absolute maximum ratings over operating free-air temperature range (unless otherwise noted)†

Supply voltage range, AV_{CC} (see Note 1)	$AV_{CC} < V_{CC} + 0.7\text{ V}$
Supply voltage range, V_{CC}	-0.5 V to 4.6 V
Input voltage range, V_I (see Note 2)	-0.5 V to 6.5 V
Voltage range applied to any output in the high or low state, V_O (see Notes 2 and 3)	-0.5 V to $V_{CC} + 0.5\text{ V}$
Input clamp current, I_{IK} ($V_I < 0$)	-50 mA
Output clamp current, I_{OK} ($V_O < 0$ or $V_O > V_{CC}$)	$\pm 50\text{ mA}$
Continuous output current, I_O ($V_O = 0$ to V_{CC})	$\pm 50\text{ mA}$
Continuous current through each V_{CC} or GND	$\pm 100\text{ mA}$
Maximum power dissipation at $T_A = 55^\circ\text{C}$ (in still air) (see Note 4)	0.7 W
Storage temperature range, T_{stg}	-65°C to 150°C

† Stresses beyond those listed under “absolute maximum ratings” may cause permanent damage to the device. These are stress ratings only, and functional operation of the device at these or any other conditions beyond those indicated under “recommended operating conditions” is not implied. Exposure to absolute-maximum-rated conditions for extended periods may affect device reliability.

NOTES: 1. AV_{CC} must not exceed V_{CC} .

2. The input and output negative-voltage ratings may be exceeded if the input and output clamp-current ratings are observed.

3. This value is limited to 4.6 V maximum.

4. The maximum package power dissipation is calculated using a junction temperature of 150°C and a board trace length of 750 mils. For more information, refer to the *Package Thermal Considerations* application note in the *ABT Advanced BiCMOS Technology Data Book*, literature number SCBD002.

recommended operating conditions (see Note 5)

	MIN	MAX	UNIT
Supply voltage, V_{CC} , AV_{CC}	3	3.6	V
High-level input voltage, V_{IH}	2		V
Low-level input voltage, V_{IL}		0.8	V
Input voltage, V_I	0	V_{CC}	V
High-level output current, I_{OH}		-12	mA
Low-level output current, I_{OL}		12	mA
Operating free-air temperature, T_A	0	85	°C

NOTE 5: Unused inputs must be held high or low to prevent them from floating.

timing requirements over recommended ranges of supply voltage and operating free-air temperature

	MIN	MAX	UNIT
f_{clk} Clock frequency	25	140	MHz
Input clock duty cycle	40%	60%	
Stabilization time‡		1	ms

‡ Time required for the integrated PLL circuit to obtain phase lock of its feedback signal to its reference signal. For phase lock to be obtained, a fixed-frequency, fixed-phase reference signal must be present at CLK. Until phase lock is obtained, the specifications for propagation delay, skew, and jitter parameters given in the switching characteristics table are not applicable. This parameter does not apply for input modulation under SSC application.



electrical characteristics over recommended operating free-air temperature range (unless otherwise noted)

PARAMETER		TEST CONDITIONS	V _{CC} , AV _{CC}	MIN	TYP [†]	MAX	UNIT
V _{IK}	Input clamp voltage	I _I = -18 mA	3 V			-1.2	V
V _{OH}	High-level output voltage	I _{OH} = -100 μA	MIN to MAX	V _{CC} -0.2			V
		I _{OH} = -12 mA	3 V	2.1			
		I _{OH} = -6 mA	3 V	2.4			
V _{OL}	Low-level output voltage	I _{OL} = 100 μA	MIN to MAX			0.2	V
		I _{OL} = 12 mA	3 V			0.8	
		I _{OL} = 6 mA	3 V			0.55	
I _{OH}	High-level output current	V _O = 1 V	3.135 V	-32			
		V _O = 1.65 V	3.3 V		-36		
		V _O = 3.135 V	3.465 V		-12		
I _{OL}	Low-level output current	V _O = 1.95 V	3.135 V	34			
		V _O = 1.65 V	3.3 V		40		
		V _O = 0.4 V	3.465 V		14		
I _I	Input current	V _I = V _{CC} or GND	3.6 V			±5	μA
I _{CC} [‡]	Supply current	V _I = V _{CC} or GND, I _O = 0, Outputs: low or high	3.6 V			10	μA
ΔI _{CC}	Change in supply current	One input at V _{CC} - 0.6 V, Other inputs at V _{CC} or GND	3.3 V to 3.6 V			500	μA
C _i	Input capacitance	V _I = V _{CC} or GND	3.3 V		4		pF
C _o	Output capacitance	V _O = V _{CC} or GND	3.3 V		6		pF

[†] For conditions shown as MIN or MAX, use the appropriate value specified under recommended operating conditions.

[‡] For I_{CC} of AV_{CC}, and I_{CC} vs Frequency (see Figures 8 and 9).

switching characteristics over recommended ranges of supply voltage and operating free-air temperature, C_L = 25 pF (see Note 6 and Figures 1 and 2)[§]

PARAMETER	FROM (INPUT)	TO (OUTPUT)	V _{CC} , AV _{CC} = 3.3 V ± 0.3 V			UNIT
			MIN	TYP	MAX	
Phase error time – static (normalized) (See Figures 3–6)	CLKIN↑ = 66 MHz to 133 MHz	FBIN↑	-125		125	ps
t _{sk(o)} Output skew time [¶]	Any Y or FBOU	Any Y or FBOU			200	ps
Phase error time – jitter (see Note 7)	Clkin = 66 MHz to 100 MHz	Any Y or FBOU	-50		50	ps
Jitter _(cycle-cycle) (See Figure 7)		Any Y or FBOU		[70]		
	Clkin = 100 MHz to 133 MHz	Any Y or FBOU			[65]	
Duty cycle	F(clkin > 60 MHz)	Any Y or FBOU	45%		55%	
t _r Rise time (See Notes 8 and 9)	V _O = 1.2 V to 1.8 V, IBIS simulation	Any Y or FBOU	2.5		1	V/ns
t _f Fall time (See Notes 8 and 9)	V _O = 1.2 V to 1.8 V, IBIS simulation	Any Y or FBOU	2.5		1	V/ns

[§] These parameters are not production tested.

[¶] The t_{sk(o)} specification is only valid for equal loading of all outputs.

- NOTES:
- The specifications for parameters in this table are applicable only after any appropriate stabilization time has elapsed.
 - Calculated per PC DRAM SPEC (t_{phase error, static - jitter}(cycle-to-cycle)).
 - This is equivalent to 0.8 ns/2.5 ns and 0.8 ns/2.7 ns into standard 500 Ω/ 30 pf load for output swing of 0.4 V to 2 V.
 - 64 MB DIMM configuration according to PC SDRAM Registered DIMM Design Support Document, Figure 20 and Table 13.

Intel is a trademark of Intel Corporation.

PC SDRAM Register DIMM Design Support Document is published by Intel Corporation.

CDCF2509

3.3-V PHASE-LOCK LOOP CLOCK DRIVER

SCAS624B – APRIL 1999 – REVISED MARCH 2001

PARAMETER MEASUREMENT INFORMATION

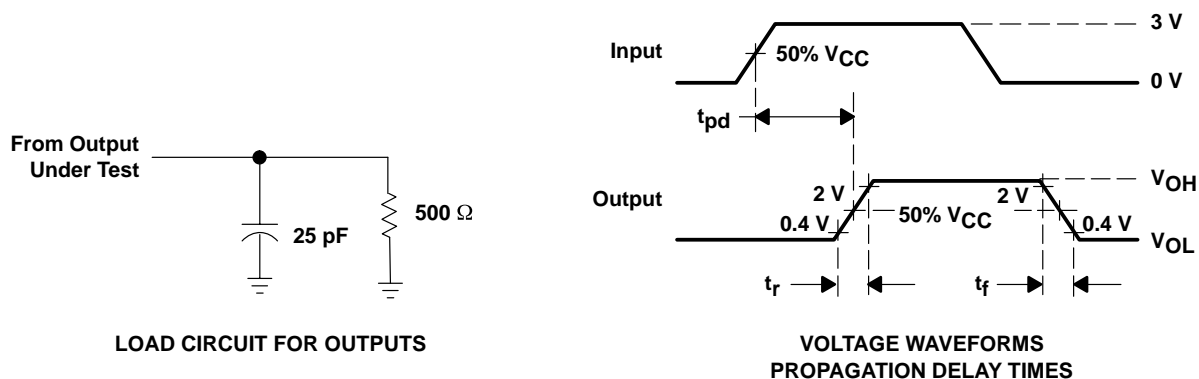

- NOTES: A. C_L includes probe and jig capacitance.
 B. All input pulses are supplied by generators having the following characteristics: $PRR \leq 133$ MHz, $Z_O = 50 \Omega$, $t_r \leq 1.2$ ns, $t_f \leq 1.2$ ns.
 C. The outputs are measured one at a time with one transition per measurement.

Figure 1. Load Circuit and Voltage Waveforms

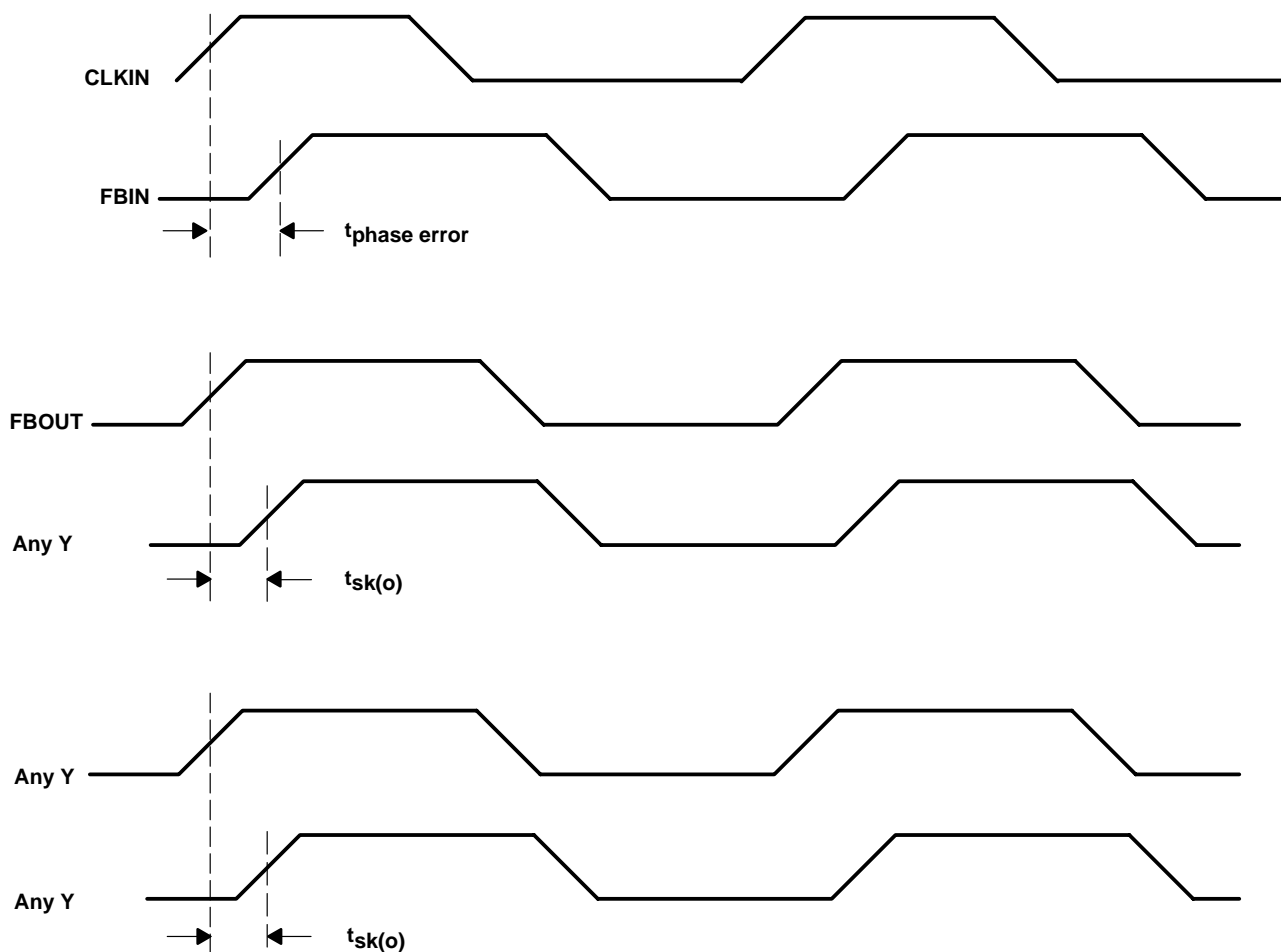

Figure 2. Phase Error and Skew Calculations

TYPICAL CHARACTERISTICS

PHASE ADJUSTMENT SLOPE AND PHASE ERROR
vs
LOAD CAPACITANCE

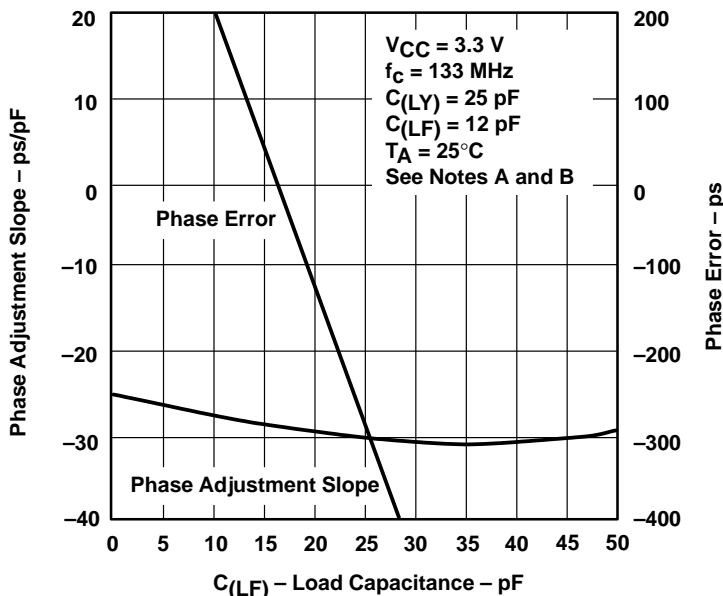

Figure 3

- NOTES: A. Trace feedback length FBOUT to FBIN = 5 mm, $Z_O = 50 \Omega$, phase error measured from CLK to Y_N
 B. $C_{(LF)}$ = Lumped feedback capacitance at FBIN

PHASE ERROR
vs
CLOCK FREQUENCY

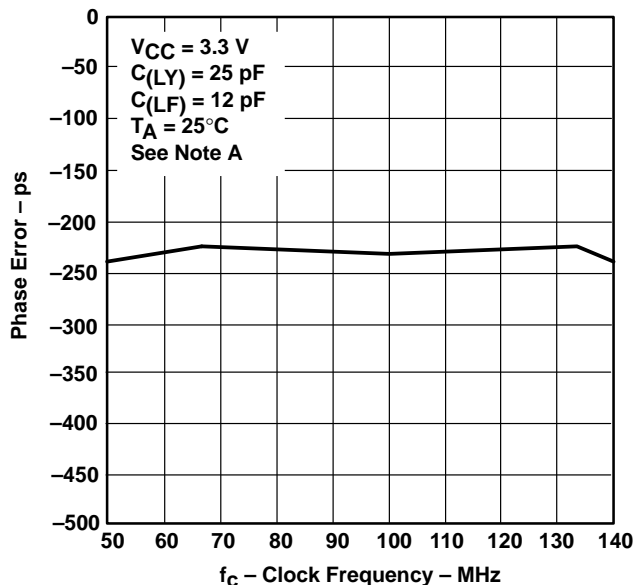

Figure 4

PHASE ERROR
vs
SUPPLY VOLTAGE

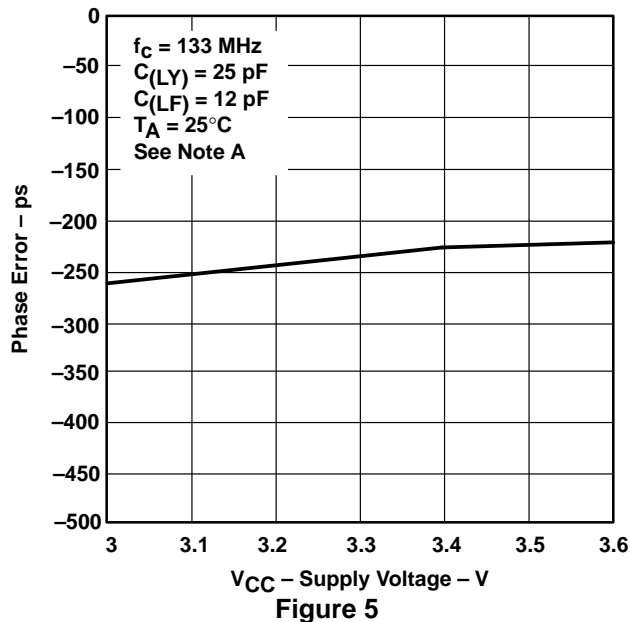

Figure 5

NOTE A: Trace feedback length FBOUT to FBIN = 5 mm, $Z_O = 50 \Omega$

CDCF2509 3.3-V PHASE-LOCK LOOP CLOCK DRIVER

SCAS624B – APRIL 1999 – REVISED MARCH 2001

TYPICAL CHARACTERISTICS

**STATIC PHASE ERROR
vs
CLOCK FREQUENCY**

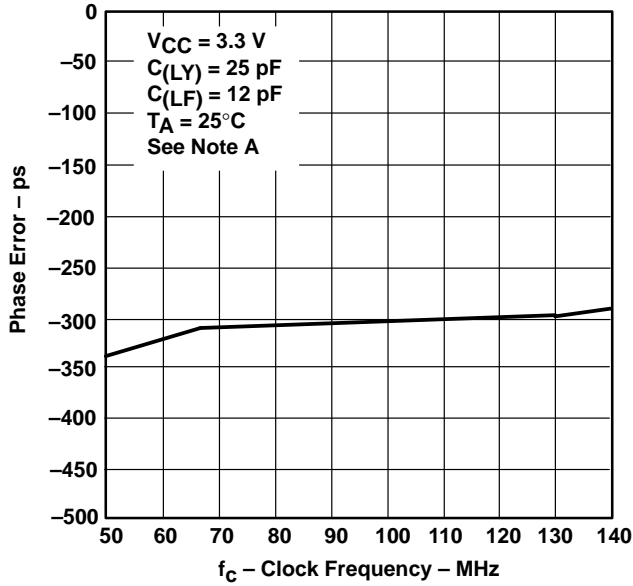

Figure 6

**JITTER
vs
CLOCK FREQUENCY**

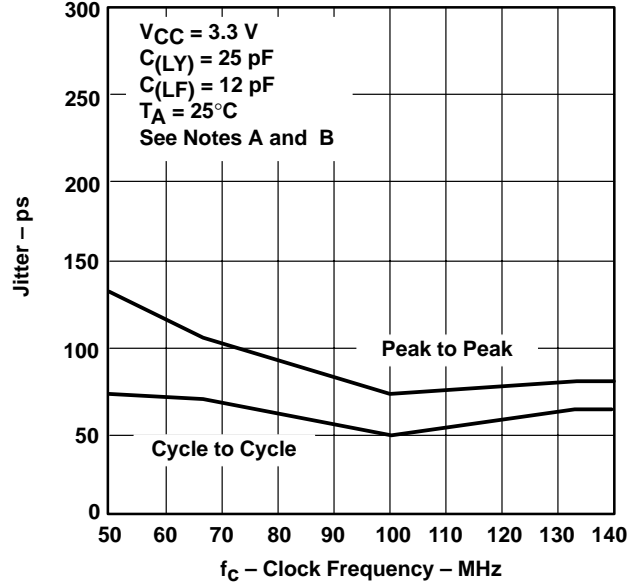

Figure 7

- NOTES: A. Trace feedback length FBOUT to FBIN = 5 mm, $Z_O = 50 \Omega$
 B. Phase error measured from CLK to FBIN
 C. $C_{(LY)}$ = Lumped capacitive load at Y
 D. $C_{(LF)}$ = Lumped feedback capacitance at FBIN

**ANALOG SUPPLY CURRENT
vs
CLOCK FREQUENCY**

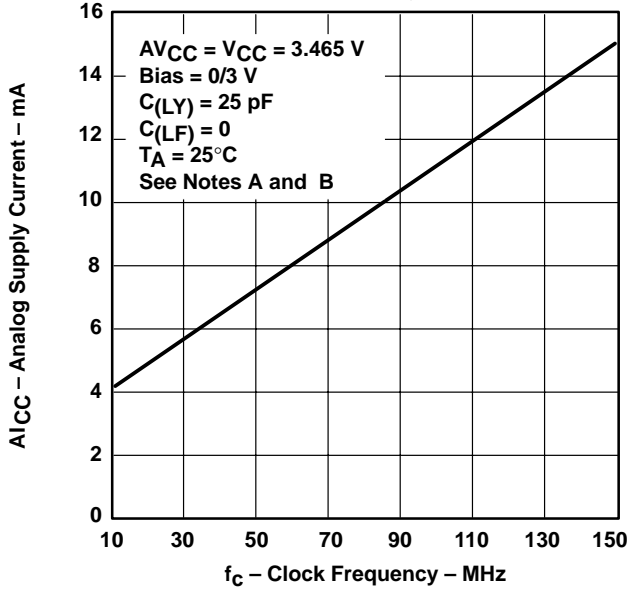

Figure 8

**SUPPLY CURRENT
vs
CLOCK FREQUENCY**

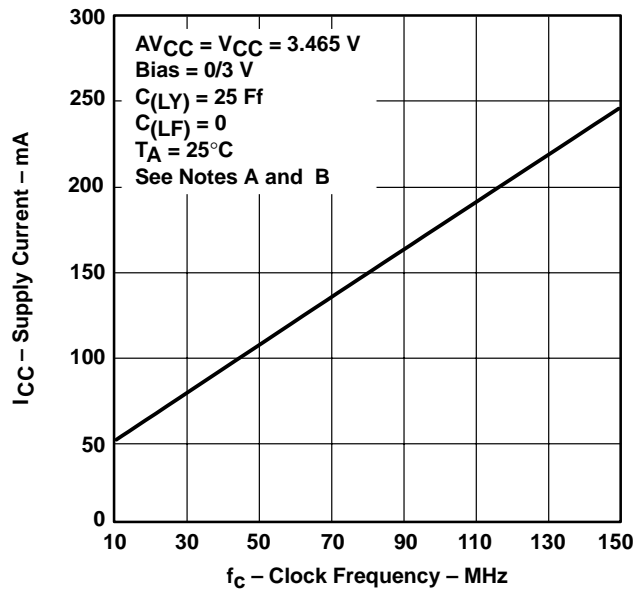

Figure 9

- NOTES: A. $C_{(LY)}$ = Lumped capacitive load at Y
 B. $C_{(LF)}$ = Lumped feedback capacitance at FBIN

MECHANICAL INFORMATION

PW (R-PDSO-G**)

PLASTIC SMALL-OUTLINE PACKAGE

14 PIN SHOWN

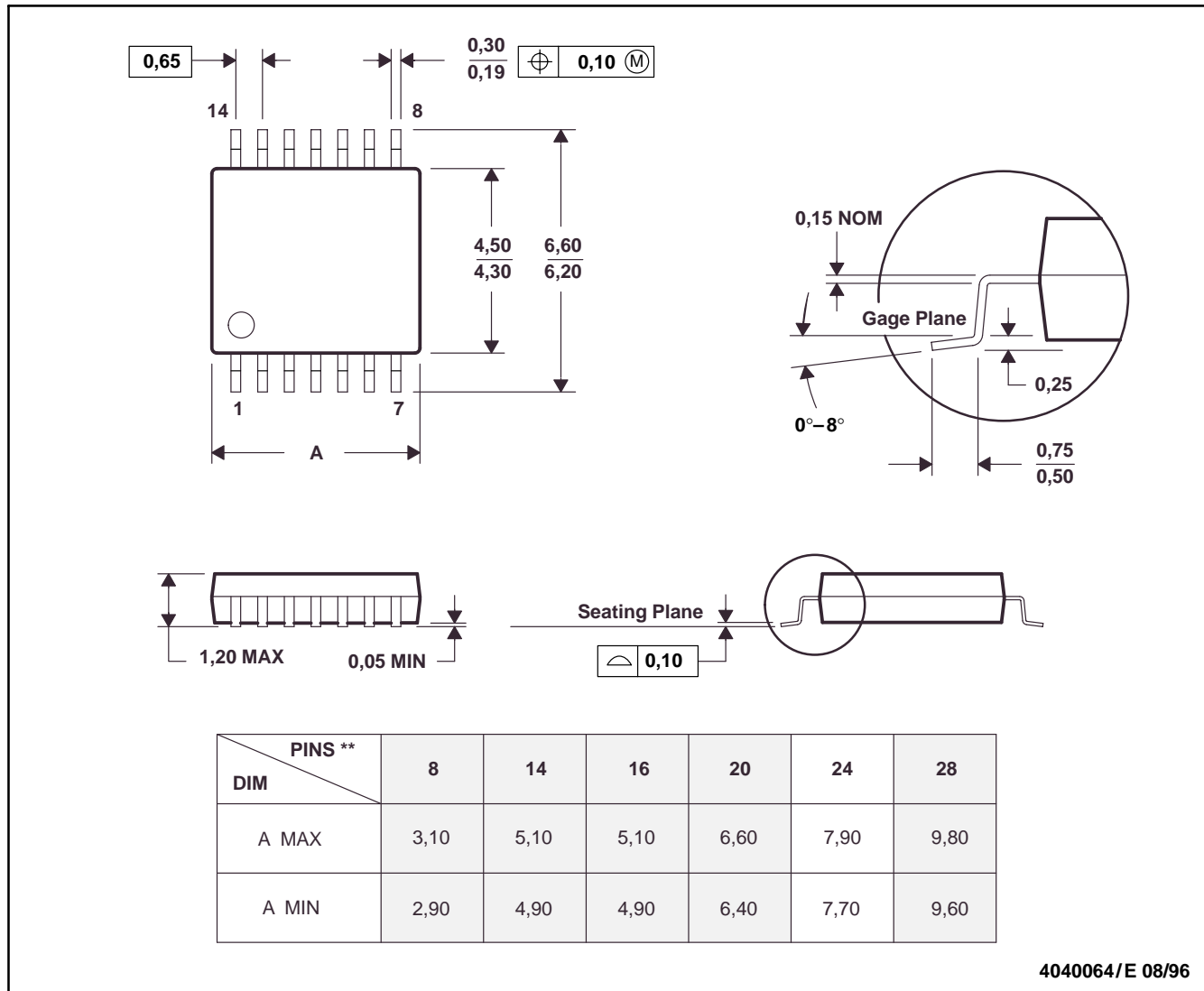

4040064/E 08/96

- NOTES: A. All linear dimensions are in millimeters.
 B. This drawing is subject to change without notice.
 C. Body dimensions do not include mold flash or protrusion not to exceed 0,15.
 D. Falls within JEDEC MO-153

IMPORTANT NOTICE

Texas Instruments and its subsidiaries (TI) reserve the right to make changes to their products or to discontinue any product or service without notice, and advise customers to obtain the latest version of relevant information to verify, before placing orders, that information being relied on is current and complete. All products are sold subject to the terms and conditions of sale supplied at the time of order acknowledgment, including those pertaining to warranty, patent infringement, and limitation of liability.

TI warrants performance of its products to the specifications applicable at the time of sale in accordance with TI's standard warranty. Testing and other quality control techniques are utilized to the extent TI deems necessary to support this warranty. Specific testing of all parameters of each device is not necessarily performed, except those mandated by government requirements.

Customers are responsible for their applications using TI components.

In order to minimize risks associated with the customer's applications, adequate design and operating safeguards must be provided by the customer to minimize inherent or procedural hazards.

TI assumes no liability for applications assistance or customer product design. TI does not warrant or represent that any license, either express or implied, is granted under any patent right, copyright, mask work right, or other intellectual property right of TI covering or relating to any combination, machine, or process in which such products or services might be or are used. TI's publication of information regarding any third party's products or services does not constitute TI's approval, license, warranty or endorsement thereof.

Reproduction of information in TI data books or data sheets is permissible only if reproduction is without alteration and is accompanied by all associated warranties, conditions, limitations and notices. Representation or reproduction of this information with alteration voids all warranties provided for an associated TI product or service, is an unfair and deceptive business practice, and TI is not responsible nor liable for any such use.

Resale of TI's products or services with statements different from or beyond the parameters stated by TI for that product or service voids all express and any implied warranties for the associated TI product or service, is an unfair and deceptive business practice, and TI is not responsible nor liable for any such use.

Also see: [Standard Terms and Conditions of Sale for Semiconductor Products](http://www.ti.com/sc/docs/stdterms.htm). www.ti.com/sc/docs/stdterms.htm

Mailing Address:

Texas Instruments
Post Office Box 655303
Dallas, Texas 75265