

Programmable 1-PLL VCXO Clock Synthesizer With 1.8-V, 2.5-V, and 3.3-V Outputs

Check for Samples: [CDCE913](#), [CDCEL913](#)

FEATURES

- Member of Programmable Clock Generator Family
 - CDCE913/CDCEL913: 1-PLL, 3 Outputs
 - CDCE925/CDCEL925: 2-PLL, 5 Outputs
 - CDCE937/CDCEL937: 3-PLL, 7 Outputs
 - CDCE949/CDCEL949: 4-PLL, 9 Outputs
- In-System Programmability and EEPROM
 - Serial Programmable Volatile Register
 - Nonvolatile EEPROM to Store Customer Setting
- Flexible Input Clocking Concept
 - External Crystal: 8 MHz to 32 MHz
 - On-Chip VCXO: Pull Range ± 150 ppm
 - Single-Ended LVCMOS up to 160 MHz
- Free Selectable Output Frequency up to 230 MHz
- Low-Noise PLL Core
 - PLL Loop Filter Components Integrated
 - Low Period Jitter (Typical 50 ps)
- Separate Output Supply Pins
 - CDCE913: 3.3 V and 2.5 V

- CDCEL913: 1.8 V
- Flexible Clock Driver
 - Three User-Definable Control Inputs [S0/S1/S2], for example., SSC Selection, Frequency Switching, Output Enable, or Power Down
 - Generates Highly Accurate Clocks for Video, Audio, USB, IEEE1394, RFID, Bluetooth™, WLAN, Ethernet™, and GPS
 - Generates Common Clock Frequencies Used With TI- DaVinci™, OMAP™, DSPs
 - Programmable SSC Modulation
 - Enables 0-PPM Clock Generation
- 1.8-V Device Power Supply
- Wide Temperature Range -40° C to 85° C
- Packaged in TSSOP
- Development and Programming Kit for Easy PLL Design and Programming (TI Pro-Clock™)

APPLICATIONS

- D-TV, STB, IP-STB, DVD-Player, DVD-Recorder, Printer

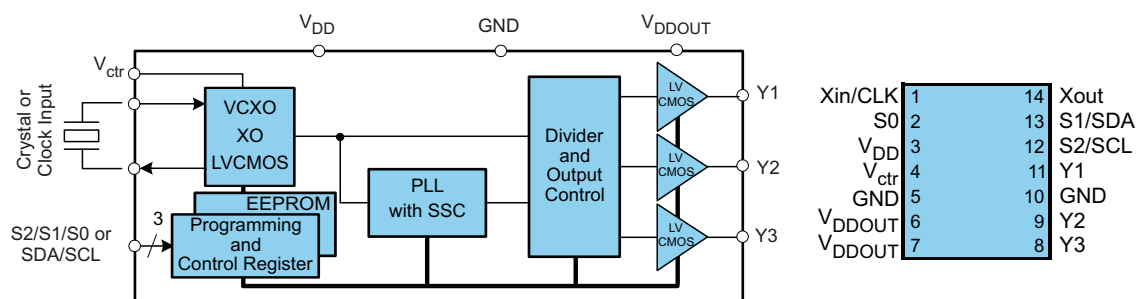

Please be aware that an important notice concerning availability, standard warranty, and use in critical applications of Texas Instruments semiconductor products and disclaimers thereto appears at the end of this data sheet.

DaVinci, OMAP, Pro-Clock are trademarks of Texas Instruments.

Bluetooth is a trademark of Bluetooth SIG.

I²C is a trademark of Philips Electronics.

Ethernet is a trademark of Xerox Corporation.



This integrated circuit can be damaged by ESD. Texas Instruments recommends that all integrated circuits be handled with appropriate precautions. Failure to observe proper handling and installation procedures can cause damage.

ESD damage can range from subtle performance degradation to complete device failure. Precision integrated circuits may be more susceptible to damage because very small parametric changes could cause the device not to meet its published specifications.

DESCRIPTION

The CDCE913 and CDCEL913 are modular PLL-based low-cost, high-performance, programmable clock synthesizers, multipliers, and dividers. They generate up to 3 output clocks from a single input frequency. Each output can be programmed in-system for any clock frequency up to 230 MHz, using the integrated configurable PLL.

The CDCx913 has separate output supply pins, V_{DDOUT} , which is 1.8 V for CDCEL913 and 2.5 V to 3.3 V for CDCE913.

The input accepts an external crystal or LVCMOS clock signal. If an external crystal is used, an on-chip load capacitor is adequate for most applications. The value of the load capacitor is programmable from 0 to 20 pF. Additionally, an on-chip VCXO is selectable which allows synchronization of the output frequency to an external control signal, that is, PWM signal.

The deep M/N divider ratio allows the generation of zero-ppm audio/video, networking (WLAN, BlueTooth, Ethernet, GPS) or interface (USB, IEEE1394, Memory Stick) clocks from e.g., a 27 MHz reference input frequency.

The PLL supports SSC (spread-spectrum clocking). SSC can be center-spread or down-spread clocking which is a common technique to reduce electro-magnetic interference (EMI).

Based on the PLL frequency and the divider settings, the internal loop filter components are automatically adjusted to achieve high stability and optimized jitter transfer characteristic.

The device supports non-volatile EEPROM programming for ease customization of the device to the application. It is preset to a factory default configuration (see the [DEFAULT DEVICE CONFIGURATION](#) section). It can be re-programmed to a different application configuration before PCB assembly, or re-programmed by in-system programming. All device settings are programmable through SDA/SCL bus, a 2-wire serial interface.

Three programmable control inputs, S0, S1 and S2, can be used to select different frequencies, or change SSC setting for lowering EMI, or other control features like, outputs disable to low, outputs 3-state, power down, PLL bypass etc).

The CDCx913 operates in a 1.8 V environment. It operates in a temperature range of -40°C to 85°C .

Terminal Functions for CDCE913, CDCEL913

TERMINAL		I/O	DESCRIPTION
NAME	PIN TSSOP14		
Y1–Y3	11, 9, 8	O	LVCMOS outputs
Xin/CLK	1	I	Crystal oscillator input or LVCMOS clock Input (selectable via SDA/SCL bus)
Xout	14	O	Crystal oscillator output (leave open or pullup when not used)
V_{Ctrl}	4	I	VCXO control voltage (leave open or pullup when not used)
V_{DD}	3	Power	1.8-V power supply for the device
V_{DDOUT}	6, 7	Power	CDCEL913: 1.8-V supply for all outputs
			CDCE913: 3.3-V or 2.5-V supply for all outputs
GND	5, 10	Ground	Ground
S0	2	I	User-programmable control input S0; LVCMOS inputs; internal pullup 500k
SDA/S1	13	I/O or I	SDA: bidirectional serial data input/output (default configuration), LVCMOS internal pullup; or S1: user-programmable control input; LVCMOS inputs; internal pullup 500k
SCL/S2	12	I	SCL: serial clock input LVCMOS (default configuration), internal pullup 500k or S2: user-programmable control input; LVCMOS inputs; internal pullup 500k

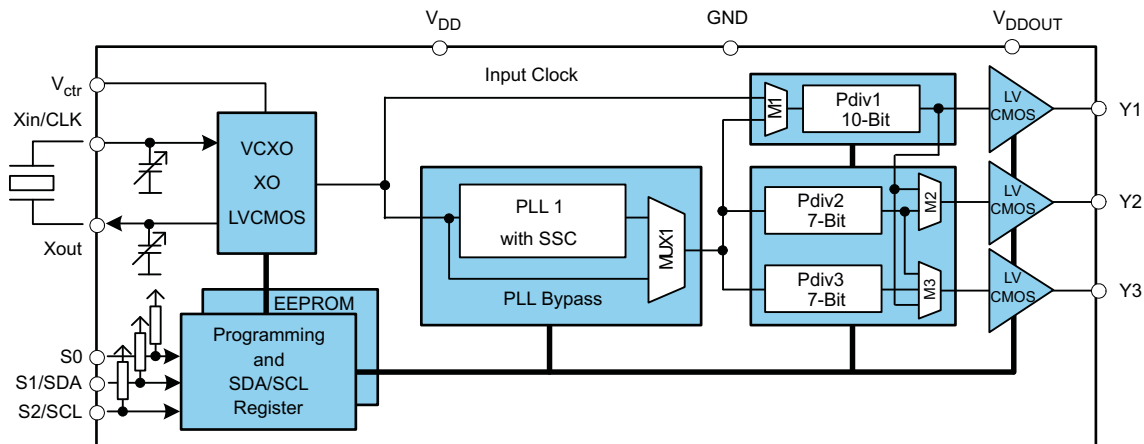

ABSOLUTE MAXIMUM RATINGS

over operating free-air temperature range (unless otherwise noted)⁽¹⁾

		VALUE	UNIT
V _{DD}	Supply voltage range	-0.5 to 2.5	V
V _I	Input voltage range ⁽²⁾ ⁽³⁾	-0.5 to V _{DD} + 0.5	V
V _O	Output voltage range ⁽²⁾	-0.5 to V _{DD} + 0.5	V
I _I	Input current (V _I < 0, V _I > V _{DD})	20	mA
I _O	Continuous output current	50	mA
T _{stg}	Storage temperature range	-65 to 150	°C
T _J	Maximum junction temperature	125	°C

(1) Stresses beyond those listed under *absolute maximum ratings* may cause permanent damage to the device. These are stress ratings only and functional operation of the device at these or any other conditions beyond those indicated under *recommended operating conditions* is not implied. Exposure to absolute-maximum-rated conditions for extended periods may affect device reliability.

(2) The input and output negative voltage ratings may be exceeded if the input and output clamp-current ratings are observed.

(3) SDA and SCL can go up to 3.6V as stated in the Recommended Operating Conditions table.

PACKAGE THERMAL RESISTANCE for TSSOP (PW) PACKAGE⁽¹⁾ ⁽²⁾

over operating free-air temperature range (unless otherwise noted)

PARAMETER		AIRFLOW (lfm)	TSSOP14 °C/W
T _{JA}	Thermal Resistance Junction to Ambient	0	106
		150	93
		200	92
		250	90
		500	85
T _{JC}	Thermal Resistance Junction to Case	—	43
T _{JB}	Thermal Resistance Junction to Board	—	66
R _{θJT}	Thermal Resistance Junction to Top	—	1.4
R _{θJB}	Thermal Resistance Junction to Bottom	—	62

(1) The package thermal impedance is calculated in accordance with JESD 51 and JEDEC2S2P (high-k board).

(2) For the most current package and ordering information, see the Package Option Addendum at the end of this document, or see the TI website at www.ti.com.

RECOMMENDED OPERATING CONDITIONS

		MIN	NOM	MAX	UNIT
V _{DD}	Device supply voltage	1.7	1.8	1.9	V
V _O	Output Yx supply voltage for CDCE913, V _{DDOUT}	2.3		3.6	V
	Output Yx supply voltage for CDCEL913, V _{DDOUT}	1.7		1.9	
V _{IL}	Low-level input voltage LVCMOS			0.3 V _{DD}	V
V _{IH}	High-level input voltage LVCMOS	0.7 V _{DD}			V
V _{I(thresh)}	Input voltage threshold LVCMOS		0.5 V _{DD}		V
V _{I(S)}	Input voltage range S0	0		1.9	V
	Input voltage range S1, S2, SDA, SCL; V _{I(thresh)} = 0.5 V _{DD}	0		3.6	
V _{I(CLK)}	Input voltage range CLK	0		1.9	V
I _{OH} / I _{OL}	Output current (V _{DDOUT} = 3.3 V)			±12	mA
	Output current (V _{DDOUT} = 2.5 V)			±10	
	Output current (V _{DDOUT} = 1.8 V)			±8	
C _L	Output load LVCMOS			15	pF
T _A	Operating free-air temperature	–40		85	°C

RECOMMENDED CRYSTAL/VCXO SPECIFICATIONS⁽¹⁾

		MIN	NOM	MAX	UNIT
f _{Xtal}	Crystal input frequency range (fundamental mode)	8	27	32	MHz
ESR	Effective series resistance			100	Ω
f _{PR}	Pulling range (0 V ≤ V _{Ctrf} ≤ 1.8 V) ⁽²⁾	±120	±150		ppm
	Frequency control voltage, V _{Ctrf}	0		V _{DD}	
C ₀ /C ₁	Pullability ratio			220	
C _L	On-chip load capacitance at Xin and Xout	0		20	pF

(1) For more information about VCXO configuration, and crystal recommendation, see application report (SCAA085).

(2) Pulling range depends on crystal-type, on-chip crystal load capacitance and PCB stray capacitance; pulling range of min ±120 ppm applies for crystal listed in the application report (SCAA085).

EEPROM SPECIFICATION

		MIN	TYP	MAX	UNIT
EEcyc	Programming cycles of EEPROM	100	1000		cycles
EEret	Data retention	10			years

TIMING REQUIREMENTS

over recommended ranges of supply voltage, load, and operating free-air temperature

			MIN	NOM	MAX	UNIT
CLK_IN REQUIREMENTS						
f _{CLK}	LVCMOS clock input frequency	PLL bypass mode	0		160	MHz
		PLL mode	8		160	
t _r / t _f	Rise and fall time CLK signal (20% to 80%)				3	ns
	Duty cycle CLK at V _{DD} /2		40%		60%	

		STANDARD MODE		FAST MODE		UNIT
		MIN	MAX	MIN	MAX	
SDA/SCL TIMING REQUIREMENTS (see Figure 12)						
f _{SCL}	SCL clock frequency	0	100	0	400	kHz
t _{SU(START)}	START setup time (SCL high before SDA low)	4.7		0.6		μs
t _{H(START)}	START hold time (SCL low after SDA low)	4		0.6		μs
t _{W(SCLL)}	SCL low-pulse duration	4.7		1.3		μs
t _{W(SCLH)}	SCL high-pulse duration	4		0.6		μs
t _{H(SDA)}	SDA hold time (SDA valid after SCL low)	0	3.45	0	0.9	μs
t _{SU(SDA)}	SDA setup time	250		100		ns
t _r	SCL/SDA input rise time		1000		300	ns
t _f	SCL/SDA input fall time		300		300	ns
t _{SU(STOP)}	STOP setup time	4		0.6		μs
t _{BUS}	Bus free time between a STOP and START condition	4.7		1.3		μs

DEVICE CHARACTERISTICS

over recommended operating free-air temperature range (unless otherwise noted)

PARAMETER		TEST CONDITIONS		MIN	TYP ⁽¹⁾	MAX	UNIT
OVERALL PARAMETER							
I _{DD}	Supply current (see Figure 3)	All outputs off, f _{CLK} = 27 MHz, f _{VCO} = 135 MHz; f _{OUT} = 27 MHz	All PLLs on		11		mA
			Per PLL		9		
I _{DD(OUT)}	Supply current (see Figure 4 and Figure 5)	No load, all outputs on, f _{OUT} = 27 MHz	V _{DDOUT} = 3.3 V		1.3		mA
			V _{DDOUT} = 1.8 V		0.7		
I _{DD(PD)}	Power-down current. Every circuit powered down except SDA/SCL	f _{IN} = 0 MHz,	V _{DD} = 1.9 V		30		μA
V _(PUC)	Supply voltage V _{dd} threshold for power-up control circuit			0.85		1.45	V
f _{VCO}	VCO frequency range of PLL			80		230	MHz
f _{OUT}	LVCMOS output frequency		V _{DDOUT} = 3.3 V			230	MHz
			V _{DDOUT} = 1.8 V			230	
LVCMOS PARAMETER							
V _{IK}	LVCMOS input voltage	V _{DD} = 1.7 V; I _I = -18 mA				-1.2	V
I _I	LVCMOS Input current	V _I = 0 V or V _{DD} ; V _{DD} = 1.9 V				±5	μA
I _{IH}	LVCMOS Input current for S0/S1/S2	V _I = V _{DD} ; V _{DD} = 1.9 V				5	μA
I _{IL}	LVCMOS Input current for S0/S1/S2	V _I = 0 V; V _{DD} = 1.9 V				-4	μA
C _I	Input capacitance at Xin/Clk	V _{Clk} = 0 V or V _{DD}				6	pF
	Input capacitance at Xout	V _{Ixout} = 0 V or V _{DD}				2	
	Input capacitance at S0/S1/S2	V _{IS} = 0 V or V _{DD}				3	
CDCE913 - LVCMOS PARAMETER FOR V_{DDOUT} = 3.3 V – MODE							
V _{OH}	LVCMOS high-level output voltage	V _{DDOUT} = 3 V, I _{OH} = -0.1 mA				2.9	V
		V _{DDOUT} = 3 V, I _{OH} = -8 mA				2.4	
		V _{DDOUT} = 3 V, I _{OH} = -12 mA				2.2	
V _{OL}	LVCMOS low-level output voltage	V _{DDOUT} = 3 V, I _{OL} = 0.1 mA				0.1	V
		V _{DDOUT} = 3 V, I _{OL} = 8 mA				0.5	
		V _{DDOUT} = 3 V, I _{OL} = 12 mA				0.8	
t _{PLH} , t _{PHL}	Propagation delay	PLL bypass				3.2	ns
t _r /t _f	Rise and fall time	V _{DDOUT} = 3.3 V (20%–80%)				0.6	ns
t _{jitter(cc)}	Cycle-to-cycle jitter ⁽²⁾ ⁽³⁾	1 PLL switching, Y2-to-Y3				50	70
t _{jitter(per)}	Peak-to-peak period jitter ⁽³⁾	1 PLL switching, Y2-to-Y3				60	100
t _{sk(o)}	Output skew ⁽⁴⁾ , See Table 2	f _{OUT} = 50 MHz; Y1-to-Y3					60
odc	Output duty cycle ⁽⁵⁾	f _{VCO} = 100 MHz; Pdiv = 1				45%	55%
CDCE913 – LVCMOS PARAMETER for V_{DDOUT} = 2.5 V – Mode							
V _{OH}	LVCMOS high-level output voltage	V _{DDOUT} = 2.3 V, I _{OH} = -0.1 mA				2.2	V
		V _{DDOUT} = 2.3 V, I _{OH} = -6 mA				1.7	
		V _{DDOUT} = 2.3 V, I _{OH} = -10 mA				1.6	
V _{OL}	LVCMOS low-level output voltage	V _{DDOUT} = 2.3 V, I _{OL} = 0.1 mA				0.1	V
		V _{DDOUT} = 2.3 V, I _{OL} = 6 mA				0.5	
		V _{DDOUT} = 2.3 V, I _{OL} = 10 mA				0.7	
t _{PLH} , t _{PHL}	Propagation delay	PLL bypass				3.6	ns
t _r /t _f	Rise and fall time	V _{DDOUT} = 2.5 V (20%–80%)				0.8	ns
t _{jitter(cc)}	Cycle-to-cycle jitter ⁽²⁾ ⁽³⁾	1 PLL switching, Y2-to-Y3				50	70
t _{jitter(per)}	Peak-to-peak period jitter ⁽³⁾	1 PLL switching, Y2-to-Y3				60	100
t _{sk(o)}	Output skew ⁽⁴⁾ , See Table 2	f _{OUT} = 50 MHz; Y1-to-Y3					60
odc	Output duty cycle ⁽⁵⁾	f _{VCO} = 100 MHz; Pdiv = 1				45%	55%

(1) All typical values are at respective nominal V_{DD}.

(2) 10000 cycles.

(3) Jitter depends on configuration. Jitter data is for input frequency = 27 MHz, f_{VCO} = 108 MHz, f_{OUT} = 27 MHz (measured at Y2).

(4) The tsk(o) specification is only valid for equal loading of each bank of outputs, and the outputs are generated from the same divider.

(5) odc depends on output rise and fall time (t_r/t_f); data sampled on rising edge (tr)

DEVICE CHARACTERISTICS (continued)

over recommended operating free-air temperature range (unless otherwise noted)

PARAMETER		TEST CONDITIONS	MIN	TYP ⁽¹⁾	MAX	UNIT
CDCEL913 — LVC MOS PARAMETER for V_{DDOUT} = 1.8 V – Mode						
V _{OH}	LVC MOS high-level output voltage	V _{DDOUT} = 1.7 V, I _{OH} = -0.1 mA	1.6			V
		V _{DDOUT} = 1.7 V, I _{OH} = -4 mA	1.4			
		V _{DDOUT} = 1.7 V, I _{OH} = -8 mA	1.1			
V _{OL}	LVC MOS low-level output voltage	V _{DDOUT} = 1.7 V, I _{OL} = 0.1 mA			0.1	V
		V _{DDOUT} = 1.7 V, I _{OL} = 4 mA			0.3	
		V _{DDOUT} = 1.7 V, I _{OL} = 8 mA			0.6	
t _{PLH} , t _{PHL}	Propagation delay	PLL bypass		2.6		ns
t _r /t _f	Rise and fall time	V _{DDOUT} = 1.8 V (20%–80%)		0.7		ns
t _{jit(cc)}	Cycle-to-cycle jitter ⁽⁶⁾ ⁽⁷⁾	1 PLL switching, Y2-to-Y3		80	110	ps
t _{jit(per)}	Peak-to-peak period jitter ⁽⁷⁾	1 PLL switching, Y2-to-Y3		100	130	ps
t _{sk(o)}	Output skew ⁽⁸⁾ , See Table 2	f _{OUT} = 50 MHz; Y1-to-Y3			50	ps
odc	Output duty cycle ⁽⁹⁾	f _{VCO} = 100 MHz; Pdiv = 1	45%		55%	
SDA/SCL PARAMETER						
V _{IK}	SCL and SDA input clamp voltage	V _{DD} = 1.7 V; I _I = -18 mA			-1.2	V
I _{IH}	SCL and SDA input current	V _I = V _{DD} ; V _{DD} = 1.9 V			±10	µA
V _{IH}	SDA/SCL input high voltage ⁽¹⁰⁾		0.7 V _{DD}			V
V _{IL}	SDA/SCL input low voltage ⁽¹⁰⁾				0.3 V _{DD}	V
V _{OL}	SDA low-level output voltage	I _{OL} = 3 mA, V _{DD} = 1.7 V			0.2 V _{DD}	V
C _I	SCL/SDA Input capacitance	V _I = 0 V or V _{DD}		3	10	pF

- (6) 10000 cycles.
- (7) Jitter depends on configuration. Jitter data is for input frequency = 27 MHz, f_{VCO} = 108 MHz, f_{OUT} = 27 MHz (measured at Y2).
- (8) The t_{sk(o)} specification is only valid for equal loading of each bank of outputs, and the outputs are generated from the same divider.
- (9) odc depends on output rise and fall time (t_r/t_f); data sampled on rising edge (tr)
- (10) SDA and SCL pins are 3.3 V tolerant.

PARAMETER MEASUREMENT INFORMATION

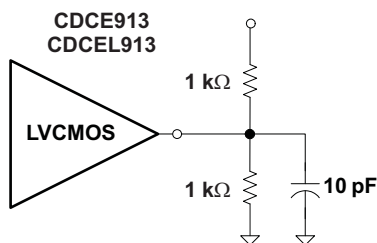

Figure 1. Test Load

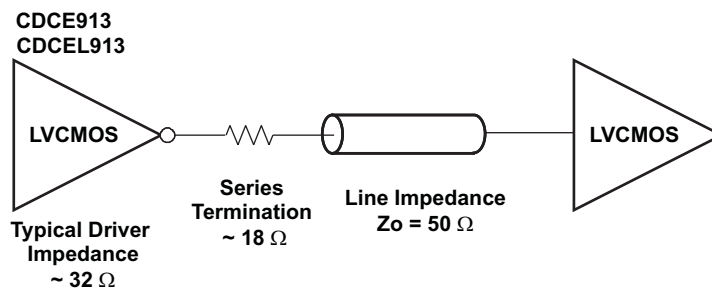

Figure 2. Test Load for 50-Ω Board Environment

TYPICAL CHARACTERISTICS

CDCE913, CDCEL913
SUPPLY CURRENT
VS
PLL FREQUENCY

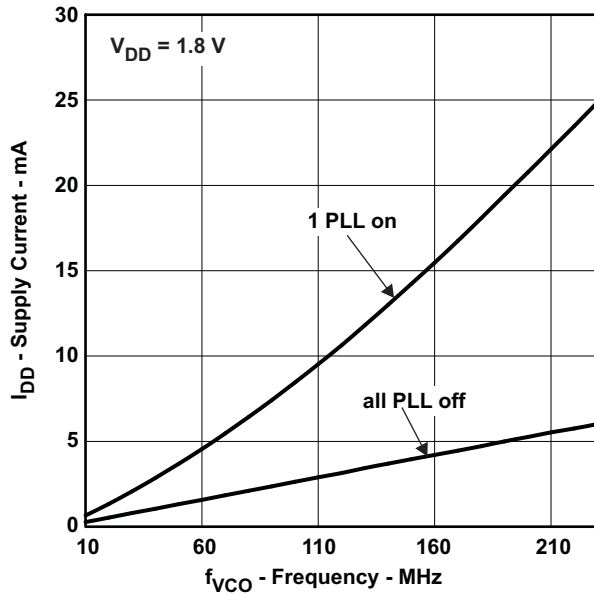

Figure 3.

CDCE913
OUTPUT CURRENT
VS
OUTPUT FREQUENCY

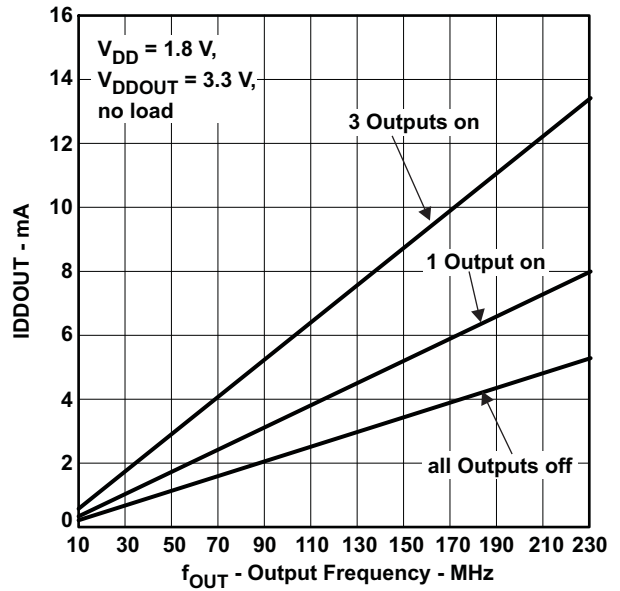

Figure 4.

CDCEL913
OUTPUT CURRENT
VS
OUTPUT FREQUENCY

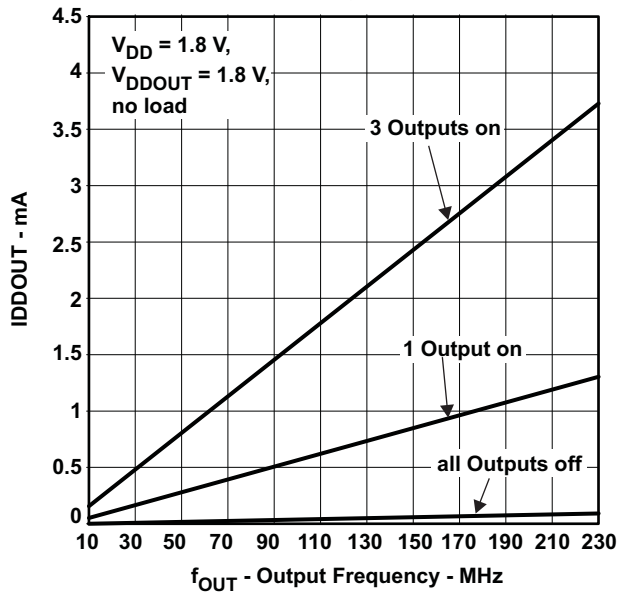

Figure 5.

APPLICATION INFORMATION

CONTROL TERMINAL CONFIGURATION

The CDCE913/CDCEL913 has three user-definable control terminals (S0, S1, and S2) which allow external control of device settings. They can be programmed to any of the following functions:

- Spread spectrum clocking selection → spread type and spread amount selection
- Frequency selection → switching between any of two user-defined frequencies
- Output state selection → output configuration and power down control

The user can predefine up to eight different control settings. [Table 1](#) and [Table 2](#) explain these settings.

Table 1. Control Terminal Definition

External Control Bits	PLL1 Setting			Y1Setting
Control Function	PLL Frequency Selection	SSC Selection	Output Y2/Y3 Selection	Output Y1 and Power-Down Selection

Table 2. PLLx Setting (can be selected for each PLL individual)⁽¹⁾

SSC Selection (Center/Down)				
SSCx [3-bits]			Center	Down
0	0	0	0% (off)	0% (off)
0	0	1	±0.25%	-0.25%
0	1	0	±0.5%	-0.5%
0	1	1	±0.75%	-0.75%
1	0	0	±1.0%	-1.0%
1	0	1	±1.25%	-1.25%
1	1	0	±1.5%	-1.5%
1	1	1	±2.0%	-2.0%
FREQUENCY SELECTION ⁽²⁾				
FSx		FUNCTION		
0		Frequency0		
1		Frequency1		
OUTPUT SELECTION ⁽³⁾ (Y2 ... Y3)				
YxYx		FUNCTION		
0		State0		
1		State1		

- (1) Center/Down-Spread, Frequency0/1 and State0/1 are user-definable in PLLx Configuration Register;
 (2) Frequency0 and Frequency1 can be any frequency within the specified f_{VCO} range.
 (3) State0/1 selection is valid for both outputs of the corresponding PLL module and can be power down, 3-state, low or active

Table 3. Y1 Setting⁽¹⁾

Y1 SELECTION	
Y1	FUNCTION
0	State 0
1	State 1

- (1) State0 and State1 are user definable in Generic Configuration Register and can be power down, 3-state, low, or active.

S1/SDA and S2/SCL pins of the CDCE913/CDCEL913 are dual function pins. In default configuration they are defined as SDA/SCL for the serial programming interface. They can be programmed as control-pins (S1/S2) by setting the appropriate bits in the EEPROM. Note that the changes to the Control Register (Bit [6] of Byte 02h) have no effect until they are written into the EEPROM.

Once they are set as control pins, the serial programming interface is no longer available. However, if V_{DDOUT} is forced to GND, the two control pins, S1 and S2, temporarily act as serial programming pins (SDA/SCL).

S0 is **not** a multi use pin; it is a control pin only.

DEFAULT DEVICE CONFIGURATION

The internal EEPROM of CDCE913/CDCEL913 is pre-configured with a factory default configuration as shown in Figure 6 (The input frequency is passed through the output as a default). This allows the device to operate in default mode without the extra production step of programming it. The default setting appears after power is supplied or after power-down/up sequence until it is reprogrammed by the user to a different application configuration. A new register setting is programmed via the serial SDA/SCL Interface.

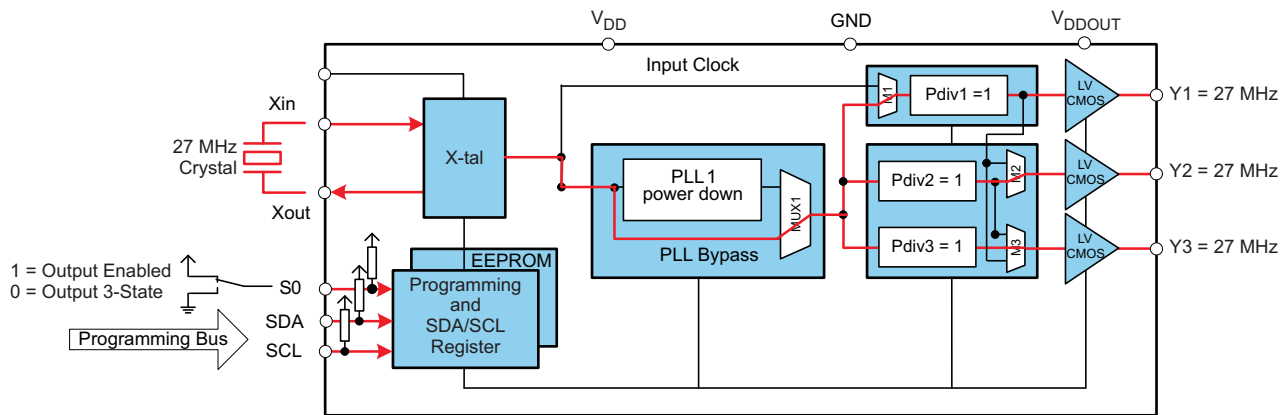

Figure 6. Default Configuration

Table 4 shows the factory default setting for the Control Terminal Register. Note that even though 8 different register settings are possible, in default configuration, only the first two settings (0 and 1) can be selected with S0, as S1 and S2 are configured as programming pins in default mode.

Table 4. Factory Default Setting for Control Terminal Register⁽¹⁾

External Control Pins			Y1	PLL1 Settings		
S2	S1	S0	Output Selection	Frequency Selection	SSC Selection	Output Selection
SCL (I2C)	SDA (I2C)	0	Y1	FS1	SSC1	Y2Y3
SCL (I2C)	SDA (I2C)	0	3-state	f _{VCO1_0}	off	3-state
SCL (I2C)	SDA (I2C)	1	enabled	f _{VCO1_0}	off	enabled

(1) In default mode or when programmed respectively, S1 and S2 act as serial programming interface, SDA/SCL. They do not have any control-pin function but they are internally interpreted as if S1=0 and S2=0. S0, however, is a control-pin which in the default mode switches all outputs ON or OFF (as previously predefined).

SDA/SCL SERIAL INTERFACE

The CDCE913/CDCEL913 operates as a slave device of the 2-wire serial SDA/SCL bus, compatible with the popular SMBus or I2C specification. It operates in the standard-mode transfer (up to 100kbit/s) and fast-mode transfer (up to 400kbit/s) and supports 7-bit addressing.

The S1/SDA and S2/SCL pins of the CDCE913/CDCEL913 are dual function pins. In the default configuration they are used as SDA/SCL serial programming interface. They can be re-programmed as general purpose control pins, S1 and S2, by changing the corresponding EEPROM setting, Byte 02h, Bit [6].

DATA PROTOCOL

The device supports *Byte Write and Byte Read* and *Block Write and Block Read* operations.

For *Byte Write/Read* operations, the system controller can individually access addressed bytes.

For *Block Write/Read* operations, the bytes are accessed in sequential order from lowest to highest byte (with most significant bit first) with the ability to stop after any complete byte has been transferred. The numbers of Bytes read-out are defined by Byte Count in the Generic Configuration Register. At Block Read instruction, all bytes defined in the Byte Count must be readout to correctly finish the read cycle.

Once a byte has been sent, it is written into the internal register and is effective immediately. This applies to each transferred byte regardless of whether this is a *Byte Write* or a *Block Write* sequence.

If the EEPROM Write Cycle is initiated, the internal SDA registers are written into the EEPROM. During this Write Cycle, data is not accepted at the SDA/SCL bus until the write cycle is completed. However, data can be read out during the programming sequence (Byte Read or Block Read). The programming status can be monitored by *EEPIP*, byte 01h–bit 6.

The offset of the indexed byte is encoded in the command code, as described in [Table 5](#).

Table 5. Slave Receiver Address (7 Bits)

DEVICE	A6	A5	A4	A3	A2	A1 ⁽¹⁾	A0 ⁽¹⁾	R/W
CDCE913/CDCEL913	1	1	0	0	1	0	1	1/0
CDCE925/CDCEL925	1	1	0	0	1	0	0	1/0
CDCE937/CDCEL937	1	1	0	1	1	0	1	1/0
CDCE949/CDCEL949	1	1	0	1	1	0	0	1/0

(1) Address bits A0 and A1 are programmable via the SDA/SCL bus (byte 01, bit [1:0]). This allows addressing up to 4 devices connected to the same SDA/SCL bus. The least-significant bit of the address byte designates a write or read operation.

COMMAND CODE DEFINITION

Table 6. Command Code Definition

BIT	DESCRIPTION
7	0 = <i>Block Read</i> or <i>Block Write</i> operation 1 = <i>Byte Read</i> or <i>Byte Write</i> operation
(6:0)	Byte Offset for <i>Byte Read</i> , <i>Block Read</i> , <i>Byte Write</i> and <i>Block Write</i> operation.

Generic Programming Sequence

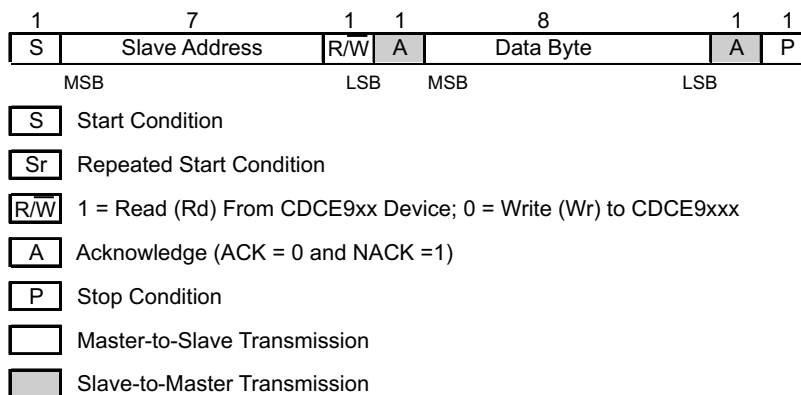

Figure 7. Generic Programming Sequence

Byte Write Programming Sequence

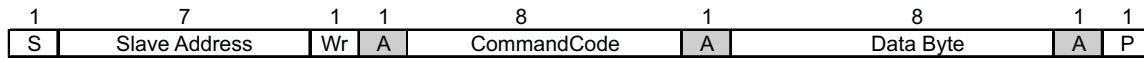

Figure 8. Byte Write Protocol

Byte Read Programming Sequence

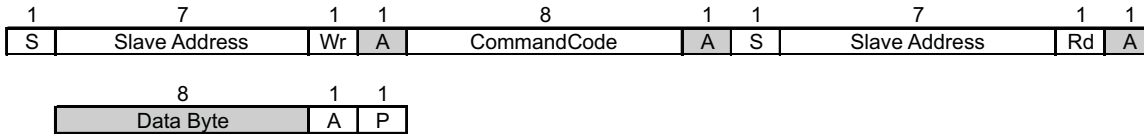
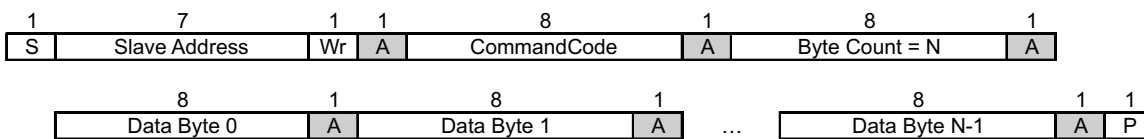

Figure 9. Byte Read Protocol

Block Write Programming Sequence



- (1) Data byte 0 bits [7:0] is reserved for Revision Code and Vendor Identification. Also, it is used for internal test purpose and should not be overwritten.

Figure 10. Block Write Protocol

Block Read Programming Sequence

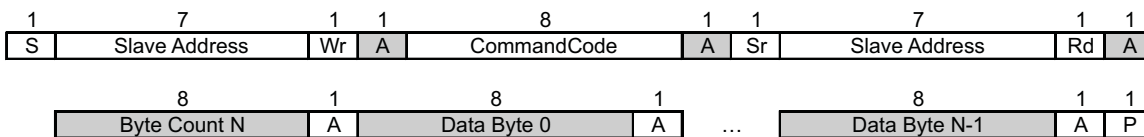

Figure 11. Block Read Protocol

Timing Diagram for the SDA/SCL Serial Control Interface

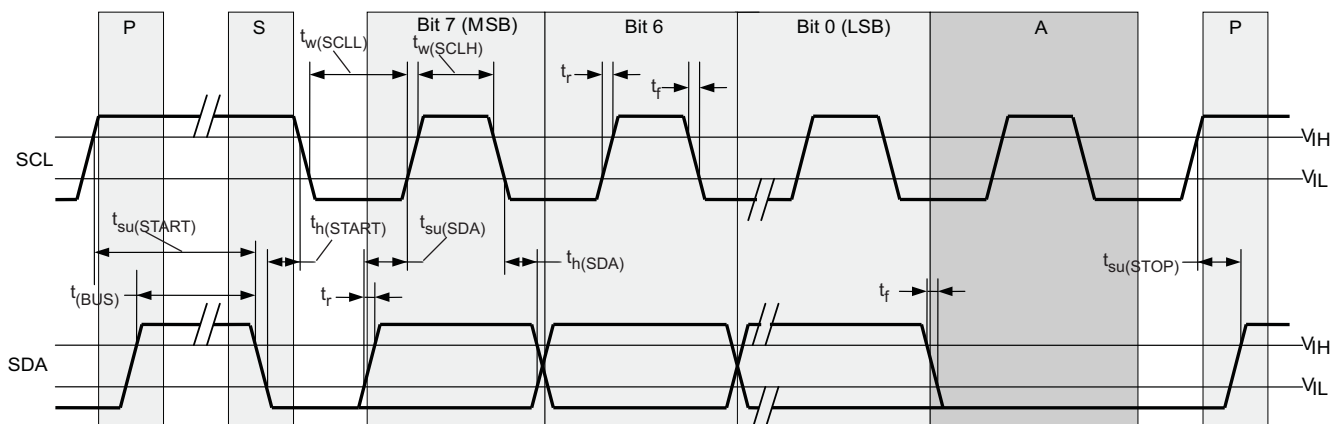

Figure 12. Timing Diagram for SDA/SCL Serial Control Interface

SDA/SCL HARDWARE INTERFACE

Figure 13 shows how the CDCE913/CDCEL913 clock synthesizer is connected to the SDA/SCL serial interface bus. Multiple devices can be connected to the bus but the speed may need to be reduced (400 kHz is the maximum) if many devices are connected.

Note that the pullup resistors (R_P) depends on the supply voltage, bus capacitance, and number of connected devices. The recommended pullup value is 4.7 k Ω . It must meet the minimum sink current of 3 mA at $V_{OLmax} = 0.4$ V for the output stages (for more details see the SMBus or I²C™ Bus specification).

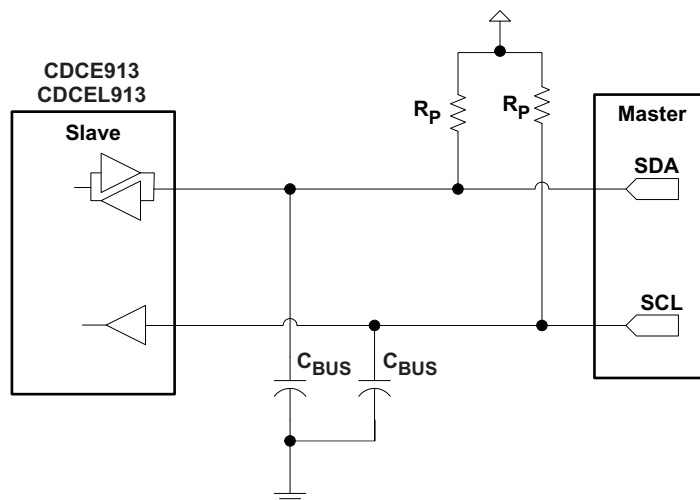

Figure 13. SDA / SCL Hardware Interface

SDA/SCL CONFIGURATION REGISTERS

The clock input, control pins, PLLs, and output stages are user configurable. The following tables and explanations describe the programmable functions of the CDCE913/CDCEL913. All settings can be manually written into the device via the SDA/SCL bus or easily programmed by using the TI Pro-Clock™ software. TI Pro-Clock™ software allows the user to quickly make all settings and automatically calculates the values for optimized performance at lowest jitter.

Table 7. SDA/SCL Registers

Address Offset	Register Description	Table
00h	Generic Configuration Register	Table 9
10h	PLL1 Configuration Register	Table 10

The grey-highlighted bits, described in the Configuration Registers tables in the following pages, belong to the Control Terminal Register. The user can predefine up to eight different control settings. These settings then can be selected by the external control pins, S0, S1, and S2. See the [Control Terminal Configuration](#) section.

**Table 8. Configuration Register,
External Control Terminals**

	External Control Pins			Y1	PLL1 Settings		
				Output Selection	Frequency Selection	SSC Selection	Output Selection
	S2	S1	S0	Y1	FS1	SSC1	Y2Y3
0	0	0	0	Y1_0	FS1_0	SSC1_0	Y2Y3_0
1	0	0	1	Y1_1	FS1_1	SSC1_1	Y2Y3_1
2	0	1	0	Y1_2	FS1_2	SSC1_2	Y2Y3_2
3	0	1	1	Y1_3	FS1_3	SSC1_3	Y2Y3_3
4	1	0	0	Y1_4	FS1_4	SSC1_4	Y2Y3_4
5	1	0	1	Y1_5	FS1_5	SSC1_5	Y2Y3_5
6	1	1	0	Y1_6	FS1_6	SSC1_6	Y2Y3_6
7	1	1	1	Y1_7	FS1_7	SSC1_7	Y2Y3_7
	Address Offset ⁽¹⁾			04h	13h	10h–12h	15h

(1) Address Offset refers to the byte address in the Configuration Register in [Table 9](#) and [Table 10](#).

Table 9. Generic Configuration Register (continued)

Offset ⁽¹⁾	Bit ⁽²⁾	Acronym	Default ⁽³⁾	Description
06h	7:1	BCOUNT	20h	7-Bit Byte Count (defines the number of bytes which will be sent from this device at the next Block Read transfer); all bytes have to be read out to correctly finish the read cycle.
	0	EEWRITE	0b	Initiate EEPROM Write Cycle ⁽⁴⁾ ⁽⁹⁾ 0 – no EEPROM write cycle 1 – start EEPROM write cycle (internal register are saved to the EEPROM)
07h-0Fh		—	0h	Unused address range

(9) The EEPROM WRITE bit must be sent last. This ensures that the content of all internal registers are stored in the EEPROM. The EEWRITE cycle is initiated with the rising edge of the EEWRITE bit. A static level high does not trigger an EEPROM WRITE cycle. The EEWRITE bit has to be reset to low after the programming is completed. The programming status can be monitored by reading out EEPIP. If EELOCK is set to high, no EEPROM programming is possible.

Table 10. PLL1 Configuration Register

OFFSET ⁽¹⁾	Bit ⁽²⁾	Acronym	Default ⁽³⁾	DESCRIPTION																		
10h	7:5	SSC1_7 [2:0]	000b	SSC1: PLL1 SSC Selection (Modulation Amount)⁽⁴⁾ <table border="0"> <tr> <td>Down</td> <td>Center</td> </tr> <tr> <td>000 (off)</td> <td>000 (off)</td> </tr> <tr> <td>001 – 0.25%</td> <td>001 ± 0.25%</td> </tr> <tr> <td>010 – 0.5%</td> <td>010 ± 0.5%</td> </tr> <tr> <td>011 – 0.75%</td> <td>011 ± 0.75%</td> </tr> <tr> <td>100 – 1.0%</td> <td>100 ± 1.0%</td> </tr> <tr> <td>101 – 1.25%</td> <td>101 ± 1.25%</td> </tr> <tr> <td>110 – 1.5%</td> <td>110 ± 1.5%</td> </tr> <tr> <td>111 – 2.0%</td> <td>111 ± 2.0%</td> </tr> </table>	Down	Center	000 (off)	000 (off)	001 – 0.25%	001 ± 0.25%	010 – 0.5%	010 ± 0.5%	011 – 0.75%	011 ± 0.75%	100 – 1.0%	100 ± 1.0%	101 – 1.25%	101 ± 1.25%	110 – 1.5%	110 ± 1.5%	111 – 2.0%	111 ± 2.0%
	Down	Center																				
	000 (off)	000 (off)																				
001 – 0.25%	001 ± 0.25%																					
010 – 0.5%	010 ± 0.5%																					
011 – 0.75%	011 ± 0.75%																					
100 – 1.0%	100 ± 1.0%																					
101 – 1.25%	101 ± 1.25%																					
110 – 1.5%	110 ± 1.5%																					
111 – 2.0%	111 ± 2.0%																					
4:2	SSC1_6 [2:0]	000b																				
1:0	SSC1_5 [2:1]	000b																				
11h	7	SSC1_5 [0]	000b																			
	6:4	SSC1_4 [2:0]	000b																			
	3:1	SSC1_3 [2:0]	000b																			
12h	0	SSC1_2 [2]	000b																			
	7:6	SSC1_2 [1:0]	000b																			
	5:3	SSC1_1 [2:0]	000b																			
13h	2:0	SSC1_0 [2:0]	000b																			
	7	FS1_7	0b	FS1_x: PLL1 Frequency Selection ⁽⁴⁾ 0 – f_{VCO1_0} (predefined by PLL1_0 – Multiplier/Divider value) 1 – f_{VCO1_1} (predefined by PLL1_1 – Multiplier/Divider value)																		
	6	FS1_6	0b																			
	5	FS1_5	0b																			
	4	FS1_4	0b																			
	3	FS1_3	0b																			
	2	FS1_2	0b																			
	1	FS1_1	0b																			
0	FS1_0	0b																				
14h	7	MUX1	1b	PLL1 Multiplexer: 0 – PLL1 1 – PLL1 Bypass (PLL1 is in power down)																		
	6	M2	1b	Output Y2 Multiplexer: 0 – Pdiv1 1 – Pdiv2																		
	5:4	M3	10b	Output Y3 Multiplexer: 00 – Pdiv1-Divider 01 – Pdiv2-Divider 10 – Pdiv3-Divider 11 – reserved																		
	3:2	Y2Y3_ST1	11b	Y2, Y3-State0/1 definition: 00 – Y2/Y3 disabled to 3-State (PLL1 is in power down) 01 – Y2/Y3 disabled to 3-State 10 – Y2/Y3 disabled to low 11 – Y2/Y3 enabled																		
	1:0	Y2Y3_ST0	01b																			
15h	7	Y2Y3_7	0b	Y2Y3_x Output State Selection ⁽⁴⁾ 0 – state0 (predefined by Y2Y3_ST0) 1 – state1 (predefined by Y2Y3_ST1)																		
	6	Y2Y3_6	0b																			
	5	Y2Y3_5	0b																			
	4	Y2Y3_4	0b																			
	3	Y2Y3_3	0b																			
	2	Y2Y3_2	0b																			
	1	Y2Y3_1	1b																			
	0	Y2Y3_0	0b																			

- (1) Writing data beyond 20h may adversely affect device function.
- (2) All data is transferred MSB-first.
- (3) Unless a custom setting is used
- (4) The user can predefine up to eight different control settings. In normal device operation, these settings can be selected by the external control pins, S0, S1, and S2.

Table 10. PLL1 Configuration Register (continued)

OFFSET ⁽¹⁾	Bit ⁽²⁾	Acronym	Default ⁽³⁾	DESCRIPTION	
16h	7	SSC1DC	0b	PLL1 SSC down/center selection:	0 – down 1 – center
	6:0	Pdiv2	01h	7-Bit Y2-Output-Divider Pdiv2:	0 – reset and stand-by 1-to-127 is divider value
17h	7	—	0b	Reserved – do not write others than 0	
	6:0	Pdiv3	01h	7-Bit Y3-Output-Divider Pdiv3:	0 – reset and stand-by 1-to-127 is divider value
18h	7:0	PLL1_0N [11:4]	004h	PLL1_0 ⁽⁵⁾ : 30-Bit Multiplier/Divider value for frequency f_{VCO1_0} (for more information, see paragraph <i>PLL Multiplier/Divider Definition</i>).	
19h	7:4	PLL1_0N [3:0]			
	3:0	PLL1_0R [8:5]	000h		
1Ah	7:3	PLL1_0R[4:0]	10h		
	2:0	PLL1_0Q [5:3]			
1Bh	7:5	PLL1_0Q [2:0]	010b		
	4:2	PLL1_0P [2:0]			
	1:0	VCO1_0_RANGE		00b	
1Ch	7:0	PLL1_1N [11:4]	004h	PLL1_1 ⁽⁵⁾ : 30-Bit Multiplier/Divider value for frequency f_{VCO1_1} (for more information see paragraph <i>PLL Multiplier/Divider Definition</i>)	
1Dh	7:4	PLL1_1N [3:0]			
	3:0	PLL1_1R [8:5]	000h		
1Eh	7:3	PLL1_1R[4:0]	10h		
	2:0	PLL1_1Q [5:3]			
1Fh	7:5	PLL1_1Q [2:0]	010b		
	4:2	PLL1_1P [2:0]			
	1:0	VCO1_1_RANGE		00b	

(5) PLL settings limits: $16 \leq q \leq 63$, $0 \leq p \leq 7$, $0 \leq r \leq 511$, $0 < N < 4096$

PLL Multiplier/Divider Definition

At a given input frequency (f_{IN}), the output frequency (f_{OUT}) of the CDCE913/CDCEL913 can be calculated:

$$f_{OUT} = \frac{f_{IN}}{P_{div}} \times \frac{N}{M} \quad (1)$$

where

M (1 to 511) and N (1 to 4095) are the multiplier/divide values of the PLL; Pdiv (1 to 127) is the output divider.

The target VCO frequency (f_{VCO}) of each PLL can be calculated:

$$f_{VCO} = f_{IN} \times \frac{N}{M} \quad (2)$$

The PLL internally operates as fractional divider and needs the following multiplier/divider settings:

- N
- $P = 4 - \text{int} \left(\log_2 \frac{N}{M} \right)$ [if $P < 0$ then $P = 0$]
- $Q = \text{int} \left(\frac{N'}{M} \right)$
- $R = N' - M \times Q$

where

$$\begin{aligned} N' &= N \times 2^P; \\ N &\geq M; \\ 100 \text{ MHz} &< f_{VCO} < 200 \text{ MHz}; \\ 16 &\leq q \leq 63 \\ 0 &\leq p \leq 7 \\ 0 &\leq r \leq 51 \end{aligned}$$

Example:

for $f_{IN} = 27 \text{ MHz}$; $M = 1$; $N = 4$; $P_{div} = 2$;

$$\begin{aligned} \rightarrow f_{OUT} &= 54 \text{ MHz} \\ \rightarrow f_{VCO} &= 108 \text{ MHz} \\ \rightarrow P &= 4 - \text{int}(\log_2 4) = 4 - 2 = 2 \\ \rightarrow N' &= 4 \times 2^2 = 16 \\ \rightarrow Q &= \text{int}(16) = 16 \\ \rightarrow R &= 16 - 16 = 0 \end{aligned}$$

for $f_{IN} = 27 \text{ MHz}$; $M = 2$; $N = 11$; $P_{div} = 2$;

$$\begin{aligned} \rightarrow f_{OUT} &= 74.25 \text{ MHz} \\ \rightarrow f_{VCO} &= 148.50 \text{ MHz} \\ \rightarrow P &= 4 - \text{int}(\log_2 5.5) = 4 - 2 = 2 \\ \rightarrow N' &= 11 \times 2^2 = 44 \\ \rightarrow Q &= \text{int}(22) = 22 \\ \rightarrow R &= 44 - 44 = 0 \end{aligned}$$

The values for P, Q, R, and N' are automatically calculated when using TI Pro-Clock™ software.

REVISION HISTORY

Changes from Revision B (December 2007) to Revision C **Page**

- Added SDA and SCL can go up to 3.6V as stated in the Recommended Operating Conditions table 3
 - Deleted 230 value, moved to Max 6
 - Deleted 230 value, moved to Max 6
-

Changes from Revision C (September) to Revision D **Page**

- Deleted sentence - A different default setting can be programmed upon customer request. Contact Texas Instruments sales or marketing representative for more information. 10
-

Changes from Revision D (October 2009) to Revision E **Page**

- Added PLL settings limits: $16 \leq q \leq 63$, $0 \leq p \leq 7$, $0 \leq r \leq 511$, $0 < N < 4096$ foot to PLL1 Configure Register Table 17
 - Added PLL settings limits: $16 \leq q \leq 63$, $0 \leq p \leq 7$, $0 \leq r \leq 511$ to PLL Multiplier/Divider Definition Section 18
-

PACKAGING INFORMATION

Orderable Device	Status ⁽¹⁾	Package Type	Package Drawing	Pins	Package Qty	Eco Plan ⁽²⁾	Lead/Ball Finish	MSL Peak Temp ⁽³⁾
CDCE913PW	ACTIVE	TSSOP	PW	14	90	Green (RoHS & no Sb/Br)	CU NIPDAU	Level-1-260C-UNLIM
CDCE913PWG4	ACTIVE	TSSOP	PW	14	90	Green (RoHS & no Sb/Br)	CU NIPDAU	Level-1-260C-UNLIM
CDCE913PWR	ACTIVE	TSSOP	PW	14	2000	Green (RoHS & no Sb/Br)	CU NIPDAU	Level-1-260C-UNLIM
CDCE913PWRG4	ACTIVE	TSSOP	PW	14	2000	Green (RoHS & no Sb/Br)	CU NIPDAU	Level-1-260C-UNLIM
CDCEL913PW	ACTIVE	TSSOP	PW	14	90	Green (RoHS & no Sb/Br)	CU NIPDAU	Level-1-260C-UNLIM
CDCEL913PWG4	ACTIVE	TSSOP	PW	14	90	Green (RoHS & no Sb/Br)	CU NIPDAU	Level-1-260C-UNLIM
CDCEL913PWR	ACTIVE	TSSOP	PW	14	2000	Green (RoHS & no Sb/Br)	CU NIPDAU	Level-1-260C-UNLIM
CDCEL913PWRG4	ACTIVE	TSSOP	PW	14	2000	Green (RoHS & no Sb/Br)	CU NIPDAU	Level-1-260C-UNLIM

⁽¹⁾ The marketing status values are defined as follows:

ACTIVE: Product device recommended for new designs.

LIFEBUY: TI has announced that the device will be discontinued, and a lifetime-buy period is in effect.

NRND: Not recommended for new designs. Device is in production to support existing customers, but TI does not recommend using this part in a new design.

PREVIEW: Device has been announced but is not in production. Samples may or may not be available.

OBSOLETE: TI has discontinued the production of the device.

⁽²⁾ Eco Plan - The planned eco-friendly classification: Pb-Free (RoHS), Pb-Free (RoHS Exempt), or Green (RoHS & no Sb/Br) - please check <http://www.ti.com/productcontent> for the latest availability information and additional product content details.

TBD: The Pb-Free/Green conversion plan has not been defined.

Pb-Free (RoHS): TI's terms "Lead-Free" or "Pb-Free" mean semiconductor products that are compatible with the current RoHS requirements for all 6 substances, including the requirement that lead not exceed 0.1% by weight in homogeneous materials. Where designed to be soldered at high temperatures, TI Pb-Free products are suitable for use in specified lead-free processes.

Pb-Free (RoHS Exempt): This component has a RoHS exemption for either 1) lead-based flip-chip solder bumps used between the die and package, or 2) lead-based die adhesive used between the die and leadframe. The component is otherwise considered Pb-Free (RoHS compatible) as defined above.

Green (RoHS & no Sb/Br): TI defines "Green" to mean Pb-Free (RoHS compatible), and free of Bromine (Br) and Antimony (Sb) based flame retardants (Br or Sb do not exceed 0.1% by weight in homogeneous material)

⁽³⁾ MSL, Peak Temp. -- The Moisture Sensitivity Level rating according to the JEDEC industry standard classifications, and peak solder temperature.

Important Information and Disclaimer:The information provided on this page represents TI's knowledge and belief as of the date that it is provided. TI bases its knowledge and belief on information provided by third parties, and makes no representation or warranty as to the accuracy of such information. Efforts are underway to better integrate information from third parties. TI has taken and continues to take reasonable steps to provide representative and accurate information but may not have conducted destructive testing or chemical analysis on incoming materials and chemicals. TI and TI suppliers consider certain information to be proprietary, and thus CAS numbers and other limited information may not be available for release.

In no event shall TI's liability arising out of such information exceed the total purchase price of the TI part(s) at issue in this document sold by TI to Customer on an annual basis.

OTHER QUALIFIED VERSIONS OF CDCEL913 :

- Automotive: [CDCEL913-Q1](#)

NOTE: Qualified Version Definitions:

- Automotive - Q100 devices qualified for high-reliability automotive applications targeting zero defects

TAPE AND REEL INFORMATION

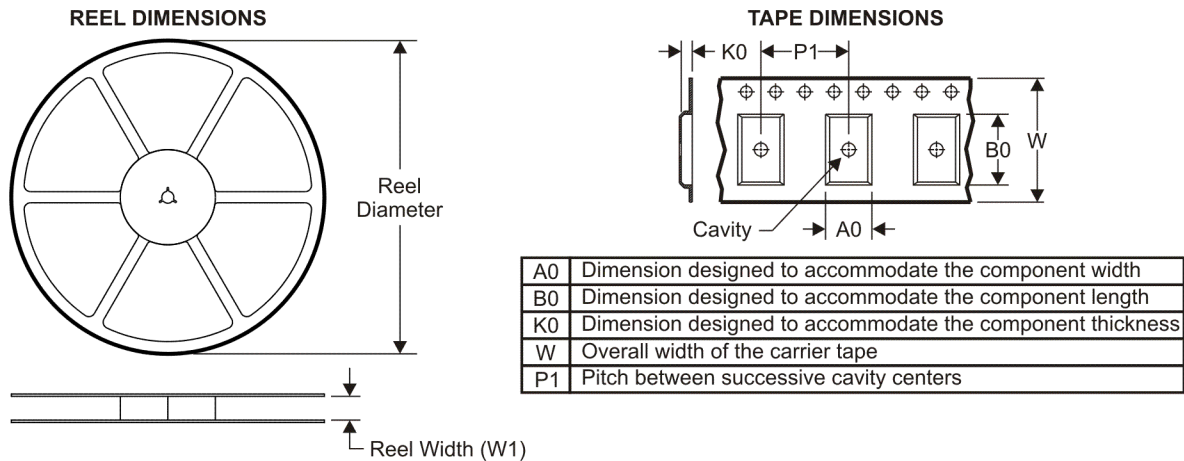

QUADRANT ASSIGNMENTS FOR PIN 1 ORIENTATION IN TAPE



*All dimensions are nominal

Device	Package Type	Package Drawing	Pins	SPQ	Reel Diameter (mm)	Reel Width W1 (mm)	A0 (mm)	B0 (mm)	K0 (mm)	P1 (mm)	W (mm)	Pin1 Quadrant
CDCE913PWR	TSSOP	PW	14	2000	330.0	12.4	7.0	5.6	1.6	8.0	12.0	Q1
CDCEL913PWR	TSSOP	PW	14	2000	330.0	12.4	7.0	5.6	1.6	8.0	12.0	Q1

TAPE AND REEL BOX DIMENSIONS

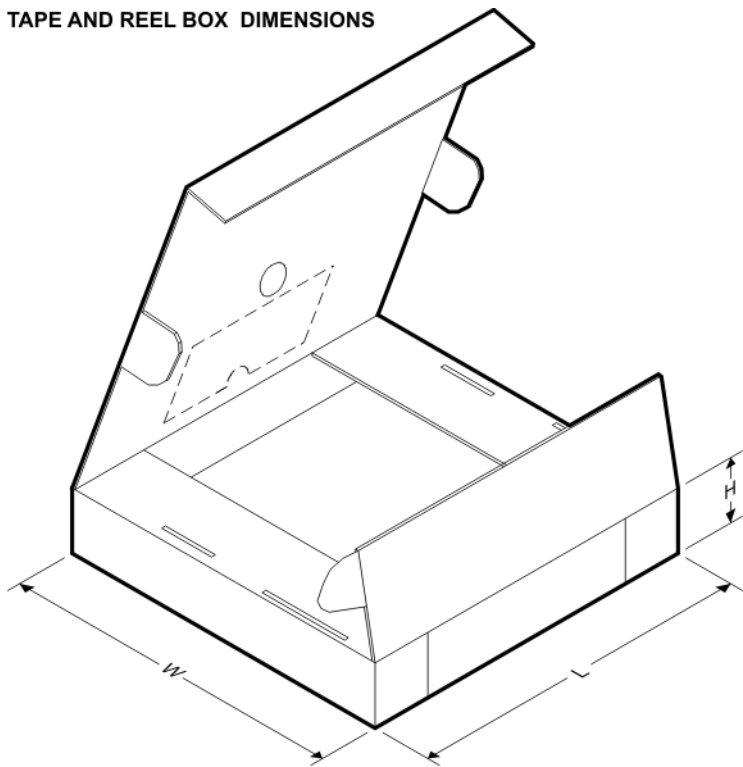

*All dimensions are nominal

Device	Package Type	Package Drawing	Pins	SPQ	Length (mm)	Width (mm)	Height (mm)
CDCE913PWR	TSSOP	PW	14	2000	346.0	346.0	29.0
CDCEL913PWR	TSSOP	PW	14	2000	346.0	346.0	29.0

PW (R-PDSO-G**)

PLASTIC SMALL-OUTLINE PACKAGE

14 PINS SHOWN



4040064/F 01/97

- NOTES: A. All linear dimensions are in millimeters.
 B. This drawing is subject to change without notice.
 C. Body dimensions do not include mold flash or protrusion not to exceed 0,15.
 D. Falls within JEDEC MO-153

IMPORTANT NOTICE

Texas Instruments Incorporated and its subsidiaries (TI) reserve the right to make corrections, modifications, enhancements, improvements, and other changes to its products and services at any time and to discontinue any product or service without notice. Customers should obtain the latest relevant information before placing orders and should verify that such information is current and complete. All products are sold subject to TI's terms and conditions of sale supplied at the time of order acknowledgment.

TI warrants performance of its hardware products to the specifications applicable at the time of sale in accordance with TI's standard warranty. Testing and other quality control techniques are used to the extent TI deems necessary to support this warranty. Except where mandated by government requirements, testing of all parameters of each product is not necessarily performed.

TI assumes no liability for applications assistance or customer product design. Customers are responsible for their products and applications using TI components. To minimize the risks associated with customer products and applications, customers should provide adequate design and operating safeguards.

TI does not warrant or represent that any license, either express or implied, is granted under any TI patent right, copyright, mask work right, or other TI intellectual property right relating to any combination, machine, or process in which TI products or services are used. Information published by TI regarding third-party products or services does not constitute a license from TI to use such products or services or a warranty or endorsement thereof. Use of such information may require a license from a third party under the patents or other intellectual property of the third party, or a license from TI under the patents or other intellectual property of TI.

Reproduction of TI information in TI data books or data sheets is permissible only if reproduction is without alteration and is accompanied by all associated warranties, conditions, limitations, and notices. Reproduction of this information with alteration is an unfair and deceptive business practice. TI is not responsible or liable for such altered documentation. Information of third parties may be subject to additional restrictions.

Resale of TI products or services with statements different from or beyond the parameters stated by TI for that product or service voids all express and any implied warranties for the associated TI product or service and is an unfair and deceptive business practice. TI is not responsible or liable for any such statements.

TI products are not authorized for use in safety-critical applications (such as life support) where a failure of the TI product would reasonably be expected to cause severe personal injury or death, unless officers of the parties have executed an agreement specifically governing such use. Buyers represent that they have all necessary expertise in the safety and regulatory ramifications of their applications, and acknowledge and agree that they are solely responsible for all legal, regulatory and safety-related requirements concerning their products and any use of TI products in such safety-critical applications, notwithstanding any applications-related information or support that may be provided by TI. Further, Buyers must fully indemnify TI and its representatives against any damages arising out of the use of TI products in such safety-critical applications.

TI products are neither designed nor intended for use in military/aerospace applications or environments unless the TI products are specifically designated by TI as military-grade or "enhanced plastic." Only products designated by TI as military-grade meet military specifications. Buyers acknowledge and agree that any such use of TI products which TI has not designated as military-grade is solely at the Buyer's risk, and that they are solely responsible for compliance with all legal and regulatory requirements in connection with such use.

TI products are neither designed nor intended for use in automotive applications or environments unless the specific TI products are designated by TI as compliant with ISO/TS 16949 requirements. Buyers acknowledge and agree that, if they use any non-designated products in automotive applications, TI will not be responsible for any failure to meet such requirements.

Following are URLs where you can obtain information on other Texas Instruments products and application solutions:

Products		Applications	
Amplifiers	amplifier.ti.com	Audio	www.ti.com/audio
Data Converters	dataconverter.ti.com	Automotive	www.ti.com/automotive
DLP® Products	www.dlp.com	Communications and Telecom	www.ti.com/communications
DSP	dsp.ti.com	Computers and Peripherals	www.ti.com/computers
Clocks and Timers	www.ti.com/clocks	Consumer Electronics	www.ti.com/consumer-apps
Interface	interface.ti.com	Energy	www.ti.com/energy
Logic	logic.ti.com	Industrial	www.ti.com/industrial
Power Mgmt	power.ti.com	Medical	www.ti.com/medical
Microcontrollers	microcontroller.ti.com	Security	www.ti.com/security
RFID	www.ti-rfid.com	Space, Avionics & Defense	www.ti.com/space-avionics-defense
RF/IF and ZigBee® Solutions	www.ti.com/lprf	Video and Imaging	www.ti.com/video
		Wireless	www.ti.com/wireless-apps