

FEATURES

- Low Output Skew, Low Pulse Skew for Clock-Distribution and Clock-Generation Applications
- Operates at 3.3-V V_{CC}
- LVTTTL-Compatible Inputs and Outputs
- Supports Mixed-Mode Signal Operation (5-V Input and Output Voltages With 3.3-V V_{CC})
- Distributes One Clock Input to Ten Outputs
- Distributed V_{CC} and Ground Pins Reduce Switching Noise
- High-Drive Outputs ($-32\text{-mA } I_{OH}$, $32\text{-mA } I_{OL}$)
- State-of-the-Art EPIC-IIB™ BiCMOS Design Significantly Reduces Power Dissipation
- Package Options Include Plastic Small-Outline (DW) and Shrink Small-Outline (DB) Packages

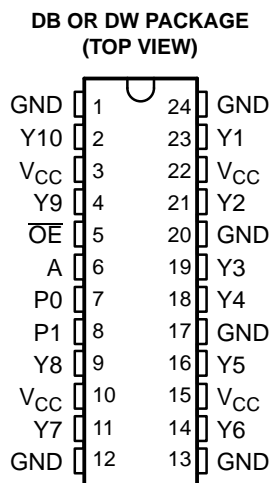

DESCRIPTION

The CDC351 is a high-performance clock-driver circuit that distributes one input (A) to ten outputs (Y) with minimum skew for clock distribution. The output-enable (\overline{OE}) input disables the outputs to a high-impedance state. The CDC351 operates at nominal 3.3-V V_{CC} .

The propagation delays are adjusted at the factory using the P0 and P1 pins. The factory adjustments ensure that the part-to-part skew is minimized and is kept within a specified window. Pins P0 and P1 are not intended for customer use and should be connected to GND.

FUNCTION TABLE

INPUTS		OUTPUTS
A	\overline{OE}	Y_n
L	H	Z
H	H	Z
L	L	L
H	L	H

AVAILABLE OPTIONS

T_A	Shrink Small-Outline Package (DB) (1)	Small-Outline Package (DW) (1)
0°C to 70°C	CDC351DB	CDC351DW
-40°C to 85°C	CDC351IDB	CDC351IDW

(1) This package is available tape and reel. Order by adding an R to the orderable part number (e.g., CDC351DBR).

EPIC-IIB is a trademark of Texas Instruments.



Please be aware that an important notice concerning availability, standard warranty, and use in critical applications of Texas Instruments semiconductor products and disclaimers thereto appears at the end of this data sheet.

CDC351. CDC351I 1-LINE TO 10-LINE CLOCK DRIVER WITH 3-STATE OUTPUTS

SCAS441D—FEBRUARY 1994—REVISED OCTOBER 2003

LOGIC SYMBOL ^A

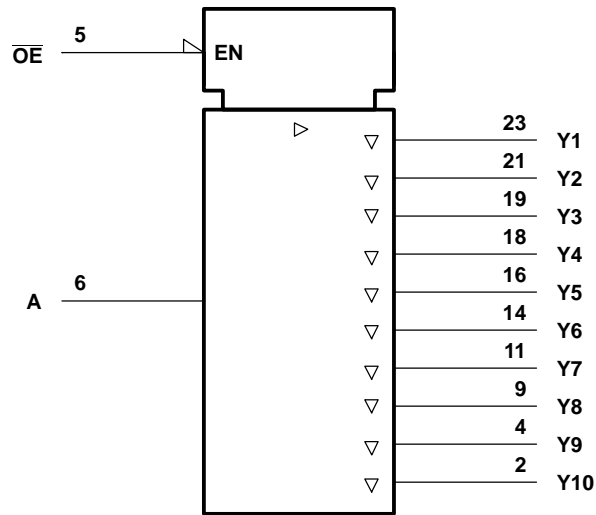

Note A: This symbol is in accordance with ANSI/IEEE Std 91-1984 and IEC Publication 617-12.

LOGIC DIAGRAM (POSITIVE LOGIC)

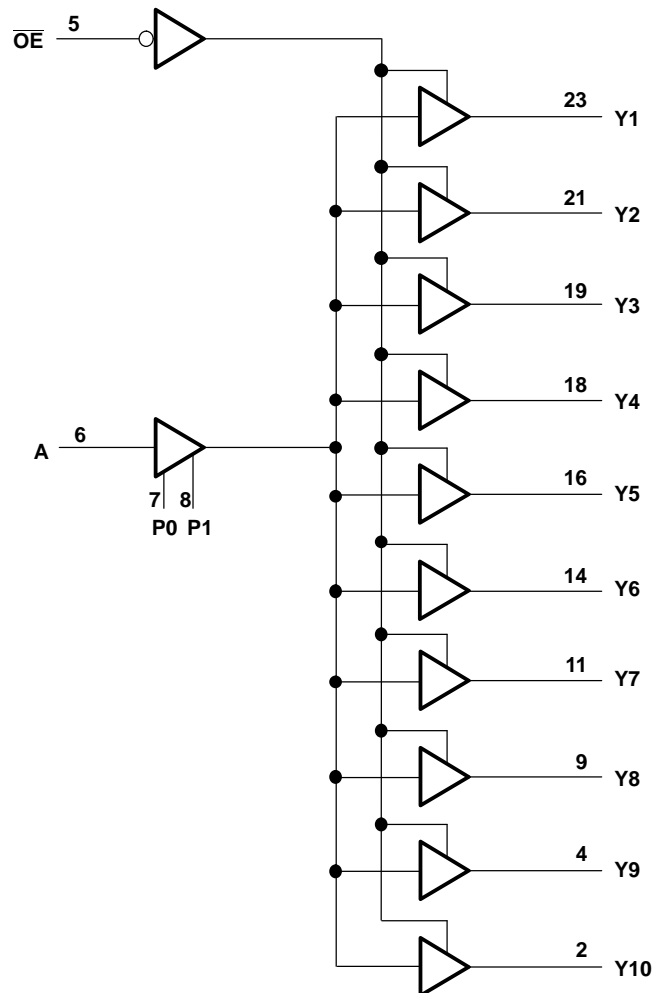

ABSOLUTE MAXIMUM RATINGS

over operating free-air temperature range (unless otherwise noted) (1)

Supply voltage range, V_{CC}		– 0.5 V to 4.6 V
Input voltage range, V_I (2)		– 0.5 V to 7 V
Voltage range applied to any output in the high state or power-off state, V_O (2)		– 0.5 V to 3.6 V
Current into any output in the low state, I_O		64 mA
Input clamp current, $I_{IK}(V_I < 0)$		– 18 mA
Output clamp current, $I_{OK}(V_I < 0)$		– 50 mA
Package thermal impedance θ_{JA} (3):	DB package	147°C/ W
	DW package	101°C/ W
Storage temperature range, T_{stg}		– 65°C to 150°C

- (1) Stresses beyond those listed under „ absolute maximum ratings” may cause permanent damage to the device. These are stress ratings only, and functional operation of the device at these or any other conditions beyond those indicated under „ recommended operating conditions” is not implied. Exposure to absolute-maximum-rated conditions for extended periods may affect device reliability.
- (2) The input and output negative-voltage ratings may be exceeded if the input and output clamp-current ratings are observed.
- (3) The package thermal impedance is calculated in accordance with JESD51.

RECOMMENDED OPERATING CONDITIONS (1)

		MIN	MAX	UNIT	
V_{CC}	Supply voltage	3	3.6	V	
V_{IH}	High-level input voltage	2		V	
V_{IL}	Low-level input voltage		0.8	V	
V_I	Input voltage	0	5.5	V	
I_{OH}	High-level output current		– 32	mA	
I_{OL}	Low-level output current		32	mA	
f_{clock}	Input clock frequency		100	MHz	
T_A	Operating free-air temperature	Commercial	0	70	°C
		Industrial	– 40	85	°C

- (1) Unused pins (input or I/O) must be held high or low.

ELECTRICAL CHARACTERISTICS

over recommended operating free-air temperature range (unless otherwise noted)

PARAMETER	TEST CONDITIONS		MIN	TYP	MAX	UNIT
V_{IK}	$V_{CC} = 3\text{ V}$,	$I_I = -18\text{ mA}$			–1.2	V
V_{OH}	$V_{CC} = 3\text{ V}$,	$I_{OH} = -32\text{ mA}$	2			V
V_{OL}	$V_{CC} = 3\text{ V}$,	$I_{OL} = 32\text{ mA}$			0.5	V
I_I	$V_{CC} = 3.6\text{ V}$,	$V_I = V_{CC}$ or GND			± 1	μA
I_O (1)	$V_{CC} = 3.6\text{ V}$,	$V_O = 2.5\text{ V}$	–15		–150	mA
I_{oz}	$V_{CC} = 3.6\text{ V}$,	$V_O = 3\text{ V}$ or 0			± 10	μA
I_{CC}	$V_{CC} = 3.6\text{ V}$, $I_O = 0$, $V_I = V_{CC}$ or GND	Outputs high			0.3	mA
		Outputs low			25	
		Outputs disabled			0.3	
C_i	$V_I = V_{CC}$ or GND,	$V_{CC} = 3.3\text{ V}$,		4		pF
C_o	$V_O = V_{CC}$ or GND,	$V_{CC} = 3.3\text{ V}$,		6		pF

- (1) Not more than one output should be tested at a time, and the duration of the test should not exceed one second.

CDC351. CDC351I

1-LINE TO 10-LINE CLOCK DRIVER WITH 3-STATE OUTPUTS

SCAS441D—FEBRUARY 1994—REVISED OCTOBER 2003

SWITCHING CHARACTERISTICS

$C_L = 50$ pF (see Figure 1 and Figure 2)

PARAMETER	FROM (INPUT)	TO (OUTPUT)	$V_{CC} = 3.3$ V, $T_A = 25^\circ$ C			$V_{CC} = 3$ V to 3.6 V, $T_A = 0^\circ$ C to 70° C		$V_{CC} = 3$ V to 3.6 V, $T_A = -40^\circ$ C to 85° C		UNIT
			MIN	TYP	MAX	MIN	MAX	MIN	MAX	
t_{PLH}	A	Y	3.2	3.7	4.2					ns
t_{PHL}			3	3.5	4					
t_{PZH}	\overline{OE}	Y	1.8	3.8	5.5	1.3	5.9	1.1	6.1	ns
t_{PZL}			1.8	3.8	5.5	1.3	5.9	1.1	6.1	
t_{PHZ}	\overline{OE}	Y	1.8	3.9	5.9	1.7	6.3	1.5	6.5	ns
t_{PLZ}			1.8	4.2	5.9	1.7	6.4	1.5	6.6	
$t_{sk(o)}$	A	Y		0.3	0.5		0.5		0.6	ns
$t_{sk(p)}$	A	Y		0.2	0.8		0.8		0.9	ns
$t_{sk(pr)}$	A	Y			1		1		1.1	ns
t_r	A	Y					1.5		1.5	ns
t_f	A	Y					1.5		1.5	ns

SWITCHING CHARACTERISTICS TEMPERATURE AND V_{CC} COEFFICIENTS

over recommended operating free-air temperature and V_{CC} range (1)

PARAMETER		FROM (INPUT)	TO (OUTPUT)	MIN	MAX	UNIT
$\$t_{PLH}(T)$	Average temperature coefficient of low to high propagation delay	A	Y		65 (2)	ps/ 10° C
$\$t_{PHL}(T)$	Average temperature coefficient of high to low propagation delay	A	Y		45 (2)	ps/ 10° C
$\$t_{PLH}(V_{CC})$	Average V_{CC} coefficient of low to high propagation delay	A	Y	-140 (3)		ps/ 100 mV
$\$t_{PHL}(V_{CC})$	Average V_{CC} coefficient of high to low propagation delay	A	Y	-120 (3)		ps/ 100 mV

- (1) These data were extracted from characterization material and are not tested at the factory.
- (2) $\$t_{PLH}(T)$ and $\$t_{PHL}(T)$ are virtually independent of V_{CC} .
- (3) $\$t_{PLH}(V_{CC})$ and $\$t_{PHL}(V_{CC})$ are virtually independent of temperature.

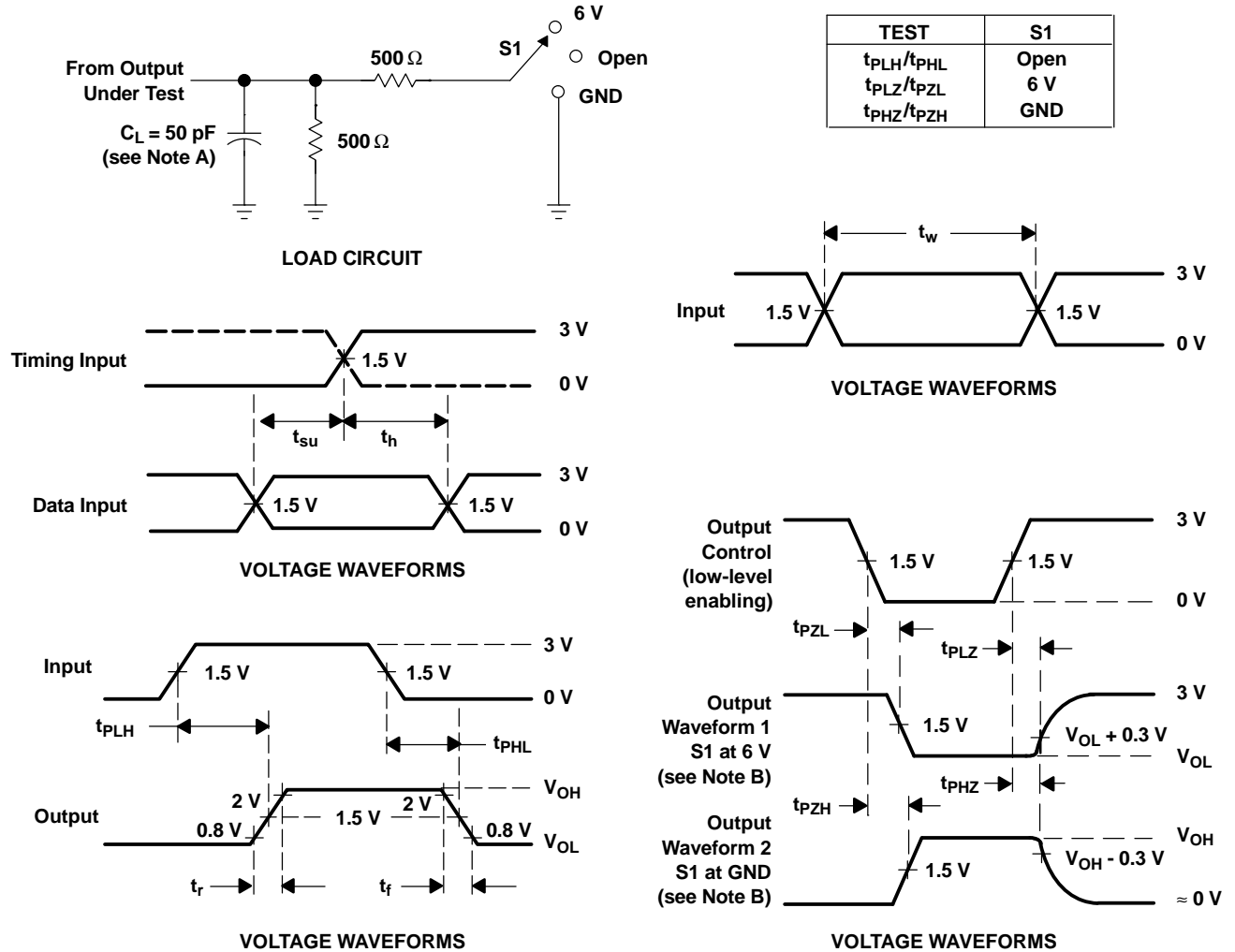

A. C_L includes probe and jig capacitance.

B. Waveform 1 is for an output with internal conditions such that the output is low except when disabled by the output control. Waveform 2 is for an output with internal conditions such that the output is high except when disabled by the output control.

C. All input pulses are supplied by generators having the following characteristics: $PRR \leq 10 \text{ MHz}$, $Z_O = 50 \Omega$, $t_r \leq 2.5 \text{ ns}$, $t_f \leq 2.5 \text{ ns}$.

D. The outputs are measured one at a time with one transition per measurement.

Figure 1. Load Circuit and Voltage Waveforms

CDC351. CDC351I 1-LINE TO 10-LINE CLOCK DRIVER WITH 3-STATE OUTPUTS

SCAS441D—FEBRUARY 1994—REVISED OCTOBER 2003

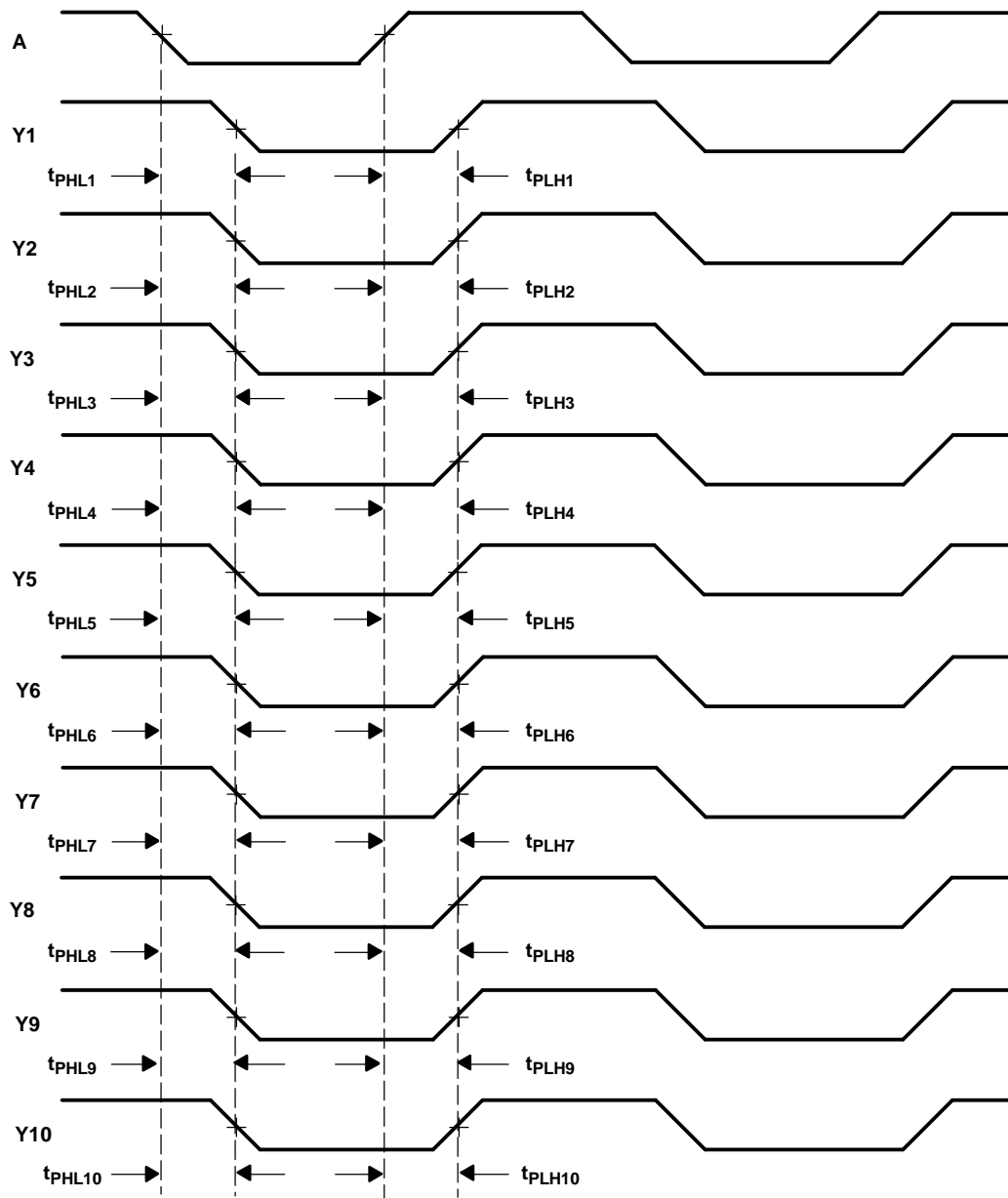

A. Output skew, $t_{sk(o)}$, is calculated as the greater of:

- The difference between the fastest and slowest of t_{PLHn} ($n = 1, 2, 3, 4, 5, 6, 7, 8, 9, 10$)
- The difference between the fastest and slowest of t_{PHLn} ($n = 1, 2, 3, 4, 5, 6, 7, 8, 9, 10$)

B. Pulse skew, $t_{sk(p)}$, is calculated as the greater of $|t_{PLHn} - t_{PHLn}|$ ($n = 1, 2, 3, 4, 5, 6, 7, 8, 9, 10$).

C. Process skew, $t_{sk(pr)}$, is calculated as the greater of:

- The difference between the fastest and slowest of t_{PLHn} ($n = 1, 2, 3, 4, 5, 6, 7, 8, 9, 10$) across multiple devices under identical operating conditions
- The difference between the fastest and slowest of t_{PHLn} ($n = 1, 2, 3, 4, 5, 6, 7, 8, 9, 10$) across multiple devices under identical operating conditions

Figure 2. Waveforms for Calculation of $t_{sk(o)}$, $t_{sk(p)}$, $t_{sk(pr)}$

PACKAGING INFORMATION

Orderable Device	Status (1)	Package Type	Package Drawing	Pins	Package Qty	Eco Plan (2)	Lead/Ball Finish	MSL Peak Temp (3)	Op Temp (°C)	Top-Side Markings (4)	Samples
CDC351DB	ACTIVE	SSOP	DB	24	60	Green (RoHS & no Sb/Br)	CU NIPDAU	Level-1-260C-UNLIM	0 to 70	CK351	Samples
CDC351DBG4	ACTIVE	SSOP	DB	24	60	Green (RoHS & no Sb/Br)	CU NIPDAU	Level-1-260C-UNLIM	0 to 70	CK351	Samples
CDC351DBLE	OBSOLETE	SSOP	DB	24		TBD	Call TI	Call TI			
CDC351DBR	ACTIVE	SSOP	DB	24	2000	Green (RoHS & no Sb/Br)	CU NIPDAU	Level-1-260C-UNLIM	0 to 70	CK351	Samples
CDC351DBRG4	ACTIVE	SSOP	DB	24	2000	Green (RoHS & no Sb/Br)	CU NIPDAU	Level-1-260C-UNLIM	0 to 70	CK351	Samples
CDC351DW	ACTIVE	SOIC	DW	24	25	Green (RoHS & no Sb/Br)	CU NIPDAU	Level-1-260C-UNLIM	0 to 70	CDC351	Samples
CDC351DWG4	ACTIVE	SOIC	DW	24	25	Green (RoHS & no Sb/Br)	CU NIPDAU	Level-1-260C-UNLIM	0 to 70	CDC351	Samples
CDC351DWR	ACTIVE	SOIC	DW	24	2000	Green (RoHS & no Sb/Br)	CU NIPDAU	Level-1-260C-UNLIM	0 to 70	CDC351	Samples
CDC351DWRG4	ACTIVE	SOIC	DW	24	2000	Green (RoHS & no Sb/Br)	CU NIPDAU	Level-1-260C-UNLIM	0 to 70	CDC351	Samples
CDC351IDB	ACTIVE	SSOP	DB	24	60	Green (RoHS & no Sb/Br)	CU NIPDAU	Level-1-260C-UNLIM	-40 to 85	CK351-I	Samples
CDC351IDBG4	ACTIVE	SSOP	DB	24	60	Green (RoHS & no Sb/Br)	CU NIPDAU	Level-1-260C-UNLIM	-40 to 85	CK351-I	Samples
CDC351IDBR	ACTIVE	SSOP	DB	24	2000	Green (RoHS & no Sb/Br)	CU NIPDAU	Level-1-260C-UNLIM	-40 to 85	CK351-I	Samples
CDC351IDBRG4	ACTIVE	SSOP	DB	24	2000	Green (RoHS & no Sb/Br)	CU NIPDAU	Level-1-260C-UNLIM	-40 to 85	CK351-I	Samples
CDC351IDW	ACTIVE	SOIC	DW	24	25	Green (RoHS & no Sb/Br)	CU NIPDAU	Level-1-260C-UNLIM	-40 to 85	CDC351-I	Samples
CDC351IDWG4	ACTIVE	SOIC	DW	24	25	Green (RoHS & no Sb/Br)	CU NIPDAU	Level-1-260C-UNLIM	-40 to 85	CDC351-I	Samples

(1) The marketing status values are defined as follows:

ACTIVE: Product device recommended for new designs.

LIFEBUY: TI has announced that the device will be discontinued, and a lifetime-buy period is in effect.

NRND: Not recommended for new designs. Device is in production to support existing customers, but TI does not recommend using this part in a new design.

PREVIEW: Device has been announced but is not in production. Samples may or may not be available.

OBSOLETE: TI has discontinued the production of the device.

⁽²⁾ Eco Plan - The planned eco-friendly classification: Pb-Free (RoHS), Pb-Free (RoHS Exempt), or Green (RoHS & no Sb/Br) - please check <http://www.ti.com/productcontent> for the latest availability information and additional product content details.

TBD: The Pb-Free/Green conversion plan has not been defined.

Pb-Free (RoHS): TI's terms "Lead-Free" or "Pb-Free" mean semiconductor products that are compatible with the current RoHS requirements for all 6 substances, including the requirement that lead not exceed 0.1% by weight in homogeneous materials. Where designed to be soldered at high temperatures, TI Pb-Free products are suitable for use in specified lead-free processes.

Pb-Free (RoHS Exempt): This component has a RoHS exemption for either 1) lead-based flip-chip solder bumps used between the die and package, or 2) lead-based die adhesive used between the die and leadframe. The component is otherwise considered Pb-Free (RoHS compatible) as defined above.

Green (RoHS & no Sb/Br): TI defines "Green" to mean Pb-Free (RoHS compatible), and free of Bromine (Br) and Antimony (Sb) based flame retardants (Br or Sb do not exceed 0.1% by weight in homogeneous material)

⁽³⁾ MSL, Peak Temp. -- The Moisture Sensitivity Level rating according to the JEDEC industry standard classifications, and peak solder temperature.

⁽⁴⁾ Multiple Top-Side Markings will be inside parentheses. Only one Top-Side Marking contained in parentheses and separated by a "~" will appear on a device. If a line is indented then it is a continuation of the previous line and the two combined represent the entire Top-Side Marking for that device.

Important Information and Disclaimer: The information provided on this page represents TI's knowledge and belief as of the date that it is provided. TI bases its knowledge and belief on information provided by third parties, and makes no representation or warranty as to the accuracy of such information. Efforts are underway to better integrate information from third parties. TI has taken and continues to take reasonable steps to provide representative and accurate information but may not have conducted destructive testing or chemical analysis on incoming materials and chemicals. TI and TI suppliers consider certain information to be proprietary, and thus CAS numbers and other limited information may not be available for release.

In no event shall TI's liability arising out of such information exceed the total purchase price of the TI part(s) at issue in this document sold by TI to Customer on an annual basis.

TAPE AND REEL INFORMATION



QUADRANT ASSIGNMENTS FOR PIN 1 ORIENTATION IN TAPE



*All dimensions are nominal

Device	Package Type	Package Drawing	Pins	SPQ	Reel Diameter (mm)	Reel Width W1 (mm)	A0 (mm)	B0 (mm)	K0 (mm)	P1 (mm)	W (mm)	Pin1 Quadrant
CDC351DBR	SSOP	DB	24	2000	330.0	16.4	8.2	8.8	2.5	12.0	16.0	Q1
CDC351DWR	SOIC	DW	24	2000	330.0	24.4	10.75	15.7	2.7	12.0	24.0	Q1
CDC351IDBR	SSOP	DB	24	2000	330.0	16.4	8.2	8.8	2.5	12.0	16.0	Q1

TAPE AND REEL BOX DIMENSIONS

*All dimensions are nominal

Device	Package Type	Package Drawing	Pins	SPQ	Length (mm)	Width (mm)	Height (mm)
CDC351DBR	SSOP	DB	24	2000	367.0	367.0	38.0
CDC351DWR	SOIC	DW	24	2000	367.0	367.0	45.0
CDC351IDBR	SSOP	DB	24	2000	367.0	367.0	38.0

DW (R-PDSO-G24)

PLASTIC SMALL OUTLINE

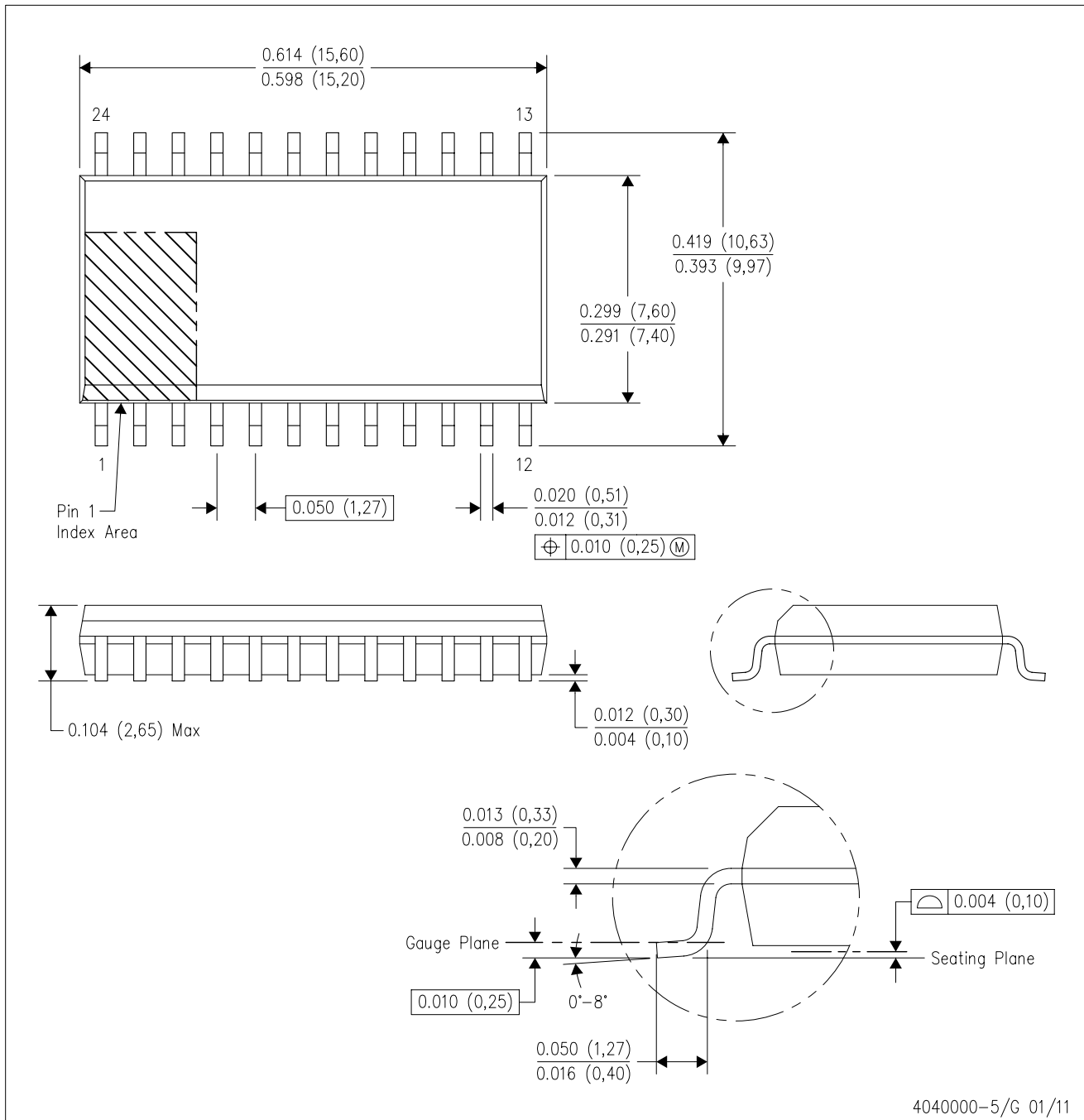

- NOTES:
- A. All linear dimensions are in inches (millimeters). Dimensioning and tolerancing per ASME Y14.5M-1994.
 - B. This drawing is subject to change without notice.
 - C. Body dimensions do not include mold flash or protrusion not to exceed 0.006 (0,15).
 - D. Falls within JEDEC MS-013 variation AD.

DB (R-PDSO-G**)

PLASTIC SMALL-OUTLINE

28 PINS SHOWN



- NOTES: A. All linear dimensions are in millimeters.
 B. This drawing is subject to change without notice.
 C. Body dimensions do not include mold flash or protrusion not to exceed 0,15.
 D. Falls within JEDEC MO-150

IMPORTANT NOTICE

Texas Instruments Incorporated and its subsidiaries (TI) reserve the right to make corrections, enhancements, improvements and other changes to its semiconductor products and services per JESD46, latest issue, and to discontinue any product or service per JESD48, latest issue. Buyers should obtain the latest relevant information before placing orders and should verify that such information is current and complete. All semiconductor products (also referred to herein as "components") are sold subject to TI's terms and conditions of sale supplied at the time of order acknowledgment.

TI warrants performance of its components to the specifications applicable at the time of sale, in accordance with the warranty in TI's terms and conditions of sale of semiconductor products. Testing and other quality control techniques are used to the extent TI deems necessary to support this warranty. Except where mandated by applicable law, testing of all parameters of each component is not necessarily performed.

TI assumes no liability for applications assistance or the design of Buyers' products. Buyers are responsible for their products and applications using TI components. To minimize the risks associated with Buyers' products and applications, Buyers should provide adequate design and operating safeguards.

TI does not warrant or represent that any license, either express or implied, is granted under any patent right, copyright, mask work right, or other intellectual property right relating to any combination, machine, or process in which TI components or services are used. Information published by TI regarding third-party products or services does not constitute a license to use such products or services or a warranty or endorsement thereof. Use of such information may require a license from a third party under the patents or other intellectual property of the third party, or a license from TI under the patents or other intellectual property of TI.

Reproduction of significant portions of TI information in TI data books or data sheets is permissible only if reproduction is without alteration and is accompanied by all associated warranties, conditions, limitations, and notices. TI is not responsible or liable for such altered documentation. Information of third parties may be subject to additional restrictions.

Resale of TI components or services with statements different from or beyond the parameters stated by TI for that component or service voids all express and any implied warranties for the associated TI component or service and is an unfair and deceptive business practice. TI is not responsible or liable for any such statements.

Buyer acknowledges and agrees that it is solely responsible for compliance with all legal, regulatory and safety-related requirements concerning its products, and any use of TI components in its applications, notwithstanding any applications-related information or support that may be provided by TI. Buyer represents and agrees that it has all the necessary expertise to create and implement safeguards which anticipate dangerous consequences of failures, monitor failures and their consequences, lessen the likelihood of failures that might cause harm and take appropriate remedial actions. Buyer will fully indemnify TI and its representatives against any damages arising out of the use of any TI components in safety-critical applications.

In some cases, TI components may be promoted specifically to facilitate safety-related applications. With such components, TI's goal is to help enable customers to design and create their own end-product solutions that meet applicable functional safety standards and requirements. Nonetheless, such components are subject to these terms.

No TI components are authorized for use in FDA Class III (or similar life-critical medical equipment) unless authorized officers of the parties have executed a special agreement specifically governing such use.

Only those TI components which TI has specifically designated as military grade or "enhanced plastic" are designed and intended for use in military/aerospace applications or environments. Buyer acknowledges and agrees that any military or aerospace use of TI components which have **not** been so designated is solely at the Buyer's risk, and that Buyer is solely responsible for compliance with all legal and regulatory requirements in connection with such use.

TI has specifically designated certain components as meeting ISO/TS16949 requirements, mainly for automotive use. In any case of use of non-designated products, TI will not be responsible for any failure to meet ISO/TS16949.

Products

Audio	www.ti.com/audio
Amplifiers	amplifier.ti.com
Data Converters	dataconverter.ti.com
DLP® Products	www.dlp.com
DSP	dsp.ti.com
Clocks and Timers	www.ti.com/clocks
Interface	interface.ti.com
Logic	logic.ti.com
Power Mgmt	power.ti.com
Microcontrollers	microcontroller.ti.com
RFID	www.ti-rfid.com
OMAP Applications Processors	www.ti.com/omap
Wireless Connectivity	www.ti.com/wirelessconnectivity

Applications

Automotive and Transportation	www.ti.com/automotive
Communications and Telecom	www.ti.com/communications
Computers and Peripherals	www.ti.com/computers
Consumer Electronics	www.ti.com/consumer-apps
Energy and Lighting	www.ti.com/energy
Industrial	www.ti.com/industrial
Medical	www.ti.com/medical
Security	www.ti.com/security
Space, Avionics and Defense	www.ti.com/space-avionics-defense
Video and Imaging	www.ti.com/video

TI E2E Community

e2e.ti.com