

CD54HC646, CD74HCT646 OCTAL BUS TRANSCEIVERS AND REGISTERS WITH 3-STATE OUTPUTS

SCHS278B – APRIL 2003 – REVISED APRIL 2003

- 2-V to 6-V V_{CC} Operation (CD54HC646)
- 4.5-V to 5.5-V V_{CC} Operation (CD74HCT646)
- Wide Operating Temperature Range of -55°C to 125°C
- Balanced Propagation Delays and Transition Times
- Standard Outputs Drive Up To 15 LS-TTL Loads
- Significant Power Reduction Compared to LS-TTL Logic ICs
- Inputs Are TTL-Voltage Compatible (CD74HCT646)
- Independent Registers for A and B Buses
- Multiplexed Real-Time and Stored Data
- True Data Paths

CD54HC646 . . . F PACKAGE
CD74HCT646 . . . M PACKAGE
(TOP VIEW)

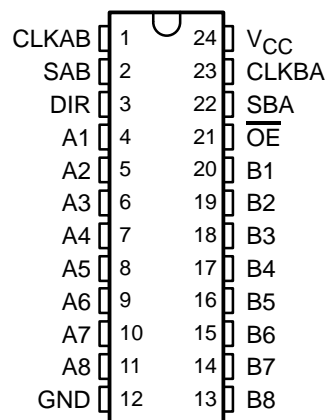

description/ordering information

The CD54HC646 and CD74HCT646 consist of bus-transceiver circuits with 3-state outputs, D-type flip-flops, and control circuitry arranged for multiplexed transmission of data directly from the input bus or from the internal registers. Data on the A or B bus is clocked into the registers on the low-to-high transition of the appropriate clock (CLKAB or CLKBA) input. Figure 1 illustrates the four fundamental bus-management functions that can be performed with these devices.

Output-enable ($\overline{\text{OE}}$) and direction-control (DIR) inputs control the transceiver functions. In the transceiver mode, data present at the high-impedance port can be stored in either or both registers.

The select-control (SAB and SBA) inputs can multiplex stored and real-time (transparent mode) data. DIR determines which bus receives data when $\overline{\text{OE}}$ is active (low). In the isolation mode ($\overline{\text{OE}}$ high), A data can be stored in one register and/or B data can be stored in the other register.

When an output function is disabled, the input function still is enabled and can be used to store data. Only one of the two buses, A or B, can be driven at a time.

To ensure the high-impedance state during power up or power down, $\overline{\text{OE}}$ should be tied to V_{CC} through a pullup resistor; the minimum value of the resistor is determined by the current-sinking capability of the driver.

ORDERING INFORMATION

T_A	PACKAGE†		ORDERABLE PART NUMBER	TOP-SIDE MARKING
-55°C to 125°C	SOIC – M	Tape and reel	CD74HCT646M96	HCT646M
	CDIP – F	Tube	CD54HC646F3A	CD54HC646F3A

† Package drawings, standard packing quantities, thermal data, symbolization, and PCB design guidelines are available at www.ti.com/sc/package.



Please be aware that an important notice concerning availability, standard warranty, and use in critical applications of Texas Instruments semiconductor products and disclaimers thereto appears at the end of this data sheet.

PRODUCTION DATA information is current as of publication date. Products conform to specifications per the terms of Texas Instruments standard warranty. Production processing does not necessarily include testing of all parameters.

 **TEXAS
INSTRUMENTS**

POST OFFICE BOX 655303 • DALLAS, TEXAS 75265

Copyright © 2003, Texas Instruments Incorporated
On products compliant to MIL-PRF-38535, all parameters are tested unless otherwise noted. On all other products, production processing does not necessarily include testing of all parameters.

CD54HC646, CD74HCT646
OCTAL BUS TRANSCEIVERS AND REGISTERS
WITH 3-STATE OUTPUTS

SCHS278B – APRIL 2003 – REVISED APRIL 2003

FUNCTION TABLE

INPUTS						DATA I/O		OPERATION OR FUNCTION
\overline{OE}	DIR	CLKAB	CLKBA	SAB	SBA	A1–A8	B1–B8	
X	X	↑	X	X	X	Input	Unspecified†	Store A, B unspecified†
X	X	X	↑	X	X	Unspecified†	Input	Store B, A unspecified†
H	X	↑	↑	X	X	Input	Input	Store A and B data
H	X	H or L	H or L	X	X	Input disabled	Input disabled	Isolation, hold storage
L	L	X	X	X	L	Output	Input	Real-time B data to A bus
L	L	X	H or L	X	H	Output	Input	Stored B data to A bus
L	H	X	X	L	X	Input	Output	Real-time A data to B bus
L	H	H or L	X	H	X	Input	Output	Stored A data to B bus

† The data-output functions can be enabled or disabled by various signals at \overline{OE} and DIR. Data-input functions always are enabled; i.e., data at the bus terminals is stored on every low-to-high transition of the clock inputs.



CD54HC646, CD74HCT646
OCTAL BUS TRANSCEIVERS AND REGISTERS
WITH 3-STATE OUTPUTS

SCHS278B – APRIL 2003 – REVISED APRIL 2003

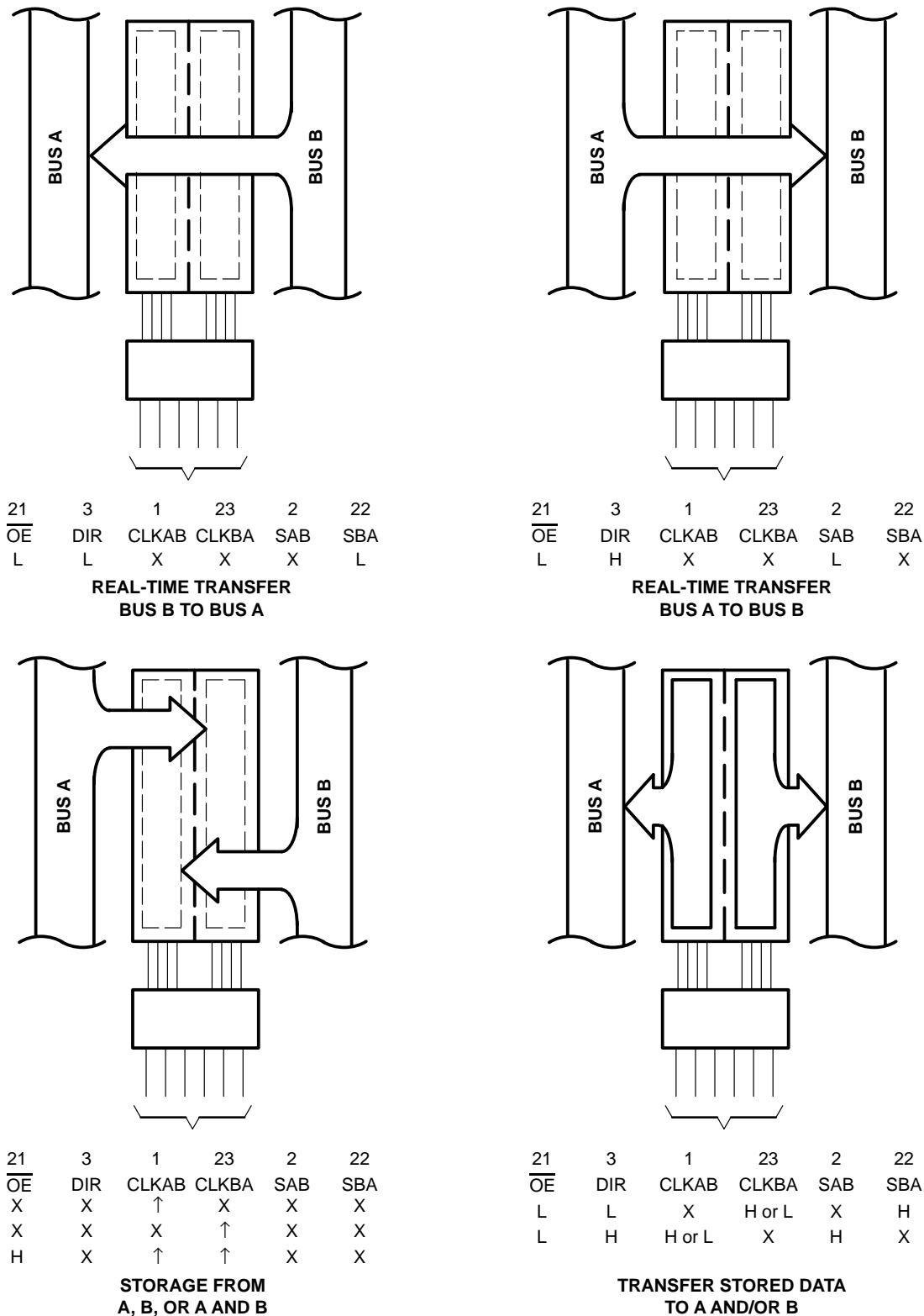
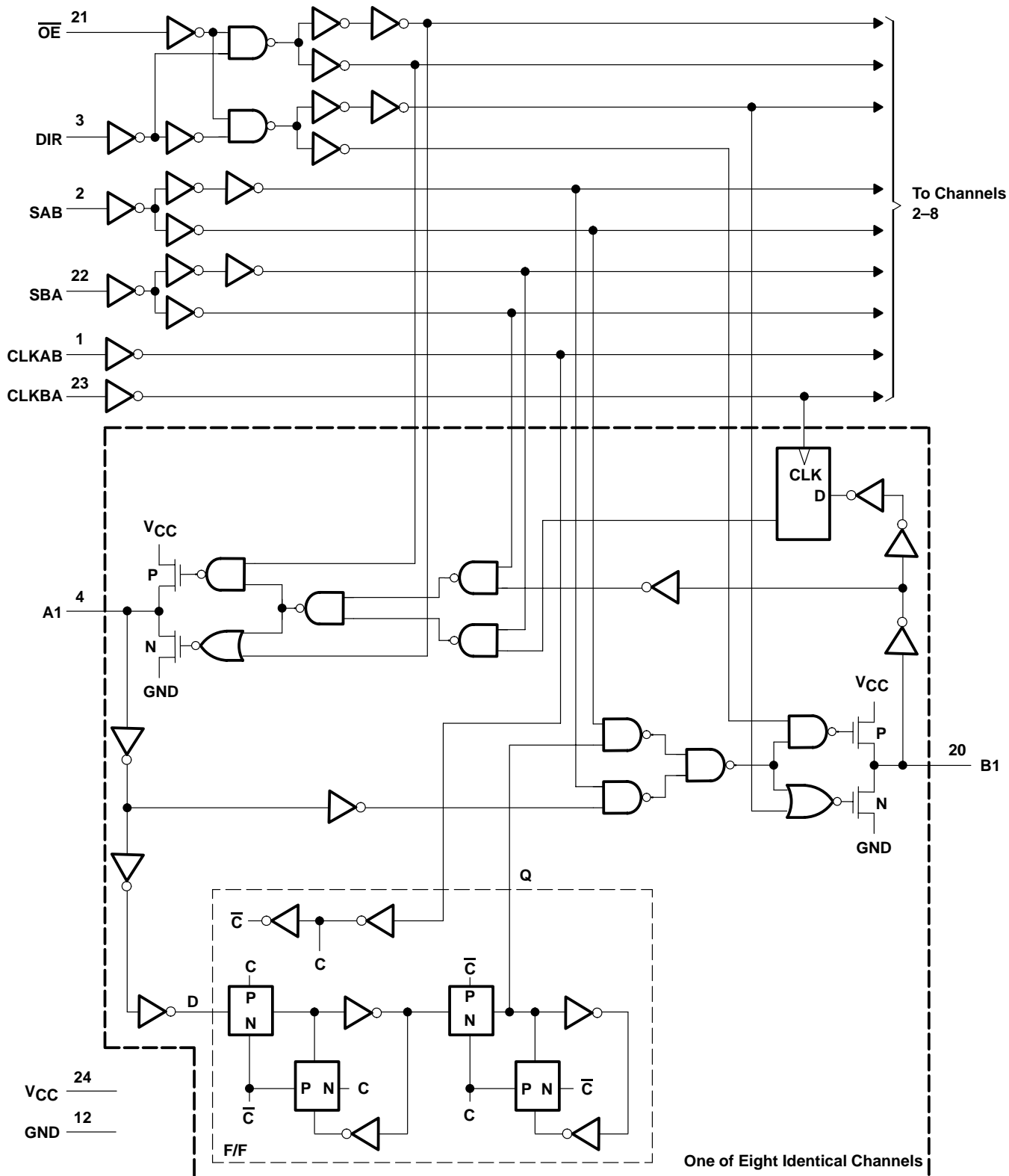

Figure 1. Bus-Management Functions

CD54HC646, CD74HCT646 OCTAL BUS TRANSCEIVERS AND REGISTERS WITH 3-STATE OUTPUTS

SCHS278B – APRIL 2003 – REVISED APRIL 2003

logic diagram (positive logic)



CD54HC646, CD74HCT646 OCTAL BUS TRANSCEIVERS AND REGISTERS WITH 3-STATE OUTPUTS

SCHS278B – APRIL 2003 – REVISED APRIL 2003

absolute maximum ratings over operating free-air temperature range (unless otherwise noted)†

Supply voltage range, V_{CC}	–0.5 V to 7 V
Input clamp current, I_{IK} ($V_I < 0$ or $V_I > V_{CC}$) (see Note 1)	±20 mA
Output clamp current, I_{OK} ($V_O < 0$ or $V_O > V_{CC}$) (see Note 1)	±20 mA
Continuous output drain current per output, I_O ($V_O = 0$ to V_{CC})	±35 mA
Continuous current through V_{CC} or GND	±50 mA
Package thermal impedance, θ_{JA} (see Note 2) M package	46°C/W
Storage temperature range, T_{stg}	–65°C to 150°C

† Stresses beyond those listed under “absolute maximum ratings” may cause permanent damage to the device. These are stress ratings only, and functional operation of the device at these or any other conditions beyond those indicated under “recommended operating conditions” is not implied. Exposure to absolute-maximum-rated conditions for extended periods may affect device reliability.

- NOTES: 1. The input and output voltage ratings may be exceeded if the input and output current ratings are observed.
2. The package thermal impedance is calculated in accordance with JESD 51-7.

recommended operating conditions for CD54HC646 (see Note 3)

		MIN	MAX	UNIT
V_{CC}	Supply voltage	2	6	V
V_{IH}	High-level input voltage	$V_{CC} = 2$ V	1.5	V
		$V_{CC} = 4.5$ V	3.15	
		$V_{CC} = 6$ V	4.2	
V_{IL}	Low-level input voltage	$V_{CC} = 2$ V	0.5	V
		$V_{CC} = 4.5$ V	1.35	
		$V_{CC} = 6$ V	1.8	
V_I	Input voltage	0	V_{CC}	V
V_O	Output voltage	0	V_{CC}	V
t_t	Input transition (rise and fall) time	$V_{CC} = 2$ V	1000	ns
		$V_{CC} = 4.5$ V	500	
		$V_{CC} = 6$ V	400	
T_A	Operating free-air temperature	–55	125	°C

NOTE 3: All unused inputs of the device must be held at V_{CC} or GND to ensure proper device operation. Refer to the TI application report, *Implications of Slow or Floating CMOS Inputs*, literature number SCBA004.

recommended operating conditions for CD74HCT646 (see Note 3)

		MIN	MAX	UNIT
V_{CC}	Supply voltage	4.5	5.5	V
V_{IH}	High-level input voltage	2		V
V_{IL}	Low-level input voltage		0.8	V
V_I	Input voltage		V_{CC}	V
V_O	Output voltage		V_{CC}	V
t_t	Input transition (rise and fall) time		500	ns
T_A	Operating free-air temperature	–55	125	°C

NOTE 4: All unused inputs of the device must be held at V_{CC} or GND to ensure proper device operation. Refer to the TI application report, *Implications of Slow or Floating CMOS Inputs*, literature number SCBA004.



CD54HC646, CD74HCT646
OCTAL BUS TRANSCEIVERS AND REGISTERS
WITH 3-STATE OUTPUTS

SCHS278B – APRIL 2003 – REVISED APRIL 2003

electrical characteristics for CD54HC646 over recommended operating free-air temperature range (unless otherwise noted)

PARAMETER	TEST CONDITIONS		V _{CC}	T _A = 25°C		T _A = -55°C TO 125°C		T _A = -40°C TO 85°C		UNIT
				MIN	MAX	MIN	MAX	MIN	MAX	
V _{OH}	V _I = V _{IH} or V _{IL}	I _{OH} = -20 μA	2 V	1.9		1.9		1.9		V
			4.5 V	4.4		4.4		4.4		
			6 V	5.9		5.9		5.9		
		I _{OH} = -6 mA	4.5 V	3.98		3.7		3.84		
		I _{OH} = -7.8 mA	6 V	5.48		5.2		5.34		
V _{OL}	V _I = V _{IH} or V _{IL}	I _{OL} = 20 μA	2 V		0.1		0.1		0.1	V
			4.5 V		0.1		0.1		0.1	
			6 V		0.1		0.1		0.1	
		I _{OL} = 6 mA	4.5 V		0.26		0.4		0.33	
		I _{OL} = 7.8 mA	6 V		0.26		0.4		0.33	
I _I	V _I = V _{CC} or 0		6 V		±0.1		±1		±1	μA
I _{OZ}	V _O = V _{CC} or 0		6 V		±0.5		±10		±5	μA
I _{CC}	V _I = V _{CC} or 0, I _O = 0		6 V		8		160		80	μA
C _i					10		10		10	pF
C _o					20		20		20	pF

electrical characteristics for CD74HCT646 over recommended operating free-air temperature range (unless otherwise noted)

PARAMETER	TEST CONDITIONS		V _{CC}	T _A = 25°C			T _A = -55°C TO 125°C		T _A = -40°C TO 85°C		UNIT
				MIN	TYP	MAX	MIN	MAX	MIN	MAX	
V _{OH}	V _I = V _{IH} or V _{IL}	I _{OH} = -20 μA	4.5 V	4.4			4.4		4.4	V	
		I _{OH} = -6 mA		3.98			3.7		3.84		
V _{OL}	V _I = V _{IH} or V _{IL}	I _{OL} = 20 μA	4.5 V		0.1		0.1		0.1	V	
		I _{OL} = 6 mA			0.26		0.4		0.33		
I _I	V _I = V _{CC} to GND		5.5 V		±0.1		±1		±1	μA	
I _{OZ}	V _O = V _{CC} or 0		5.5 V		±0.5		±10		±5	μA	
I _{CC}	V _I = V _{CC} or 0, I _O = 0		5.5 V		8		160		80	μA	
ΔI _{CC} †	One input at V _{CC} - 2.1 V, Other inputs at 0 or V _{CC}		4.5 V to 5.5 V	100	360		490		450	μA	
C _i					10		10		10	pF	
C _o					20		20		20	pF	

† Additional quiescent supply current per input pin, TTL inputs high, 1 unit load



CD54HC646, CD74HCT646 OCTAL BUS TRANSCEIVERS AND REGISTERS WITH 3-STATE OUTPUTS

SCHS278B – APRIL 2003 – REVISED APRIL 2003

HCT INPUT LOADING TABLE

INPUT	UNIT LOAD†
\overline{OE}	1.3
DIR	0.75
CLKAB or CLKBA	0.6
SAB or SBA	0.45
A or B	0.3

† Unit Load is ΔI_{CC} limit specified in electrical characteristics table (e.g., 360 μ A max at 25°C).

timing requirements for CD54HC646 over recommended operating free-air temperature range (unless otherwise noted) (see Figure 2)

	V_{CC}	$T_A = 25^\circ\text{C}$		$T_A = -55^\circ\text{C}$ TO 125°C		$T_A = -40^\circ\text{C}$ TO 85°C		UNIT
		MIN	MAX	MIN	MAX	MIN	MAX	
f_{clock} Clock frequency	2 V		6		4		5	MHz
	4.5 V		30		20		25	
	6 V		35		23		29	
t_w Pulse duration, CLKBA or CLKAB high or low	2 V		80		120		100	ns
	4.5 V		16		24		20	
	6 V		14		20		17	
t_{su} Setup time, A before CLKAB \uparrow or B before CLKBA \uparrow	2 V		60		90		75	ns
	4.5 V		12		18		15	
	6 V		10		15		13	
t_h Hold time, A after CLKAB \uparrow or B after CLKBA \uparrow	2 V		35		55		45	ns
	4.5 V		7		11		9	
	6 V		6		9		8	

timing requirements for CD74HCT646 over recommended operating free-air temperature range, $V_{CC} = 4.5\text{ V}$ (unless otherwise noted) (see Figure 3)

	$T_A = 25^\circ\text{C}$		$T_A = -55^\circ\text{C}$ TO 125°C		$T_A = -40^\circ\text{C}$ TO 85°C		UNIT
	MIN	MAX	MIN	MAX	MIN	MAX	
f_{clock} Clock frequency		25		17		20	MHz
t_w Pulse duration, CLKBA or CLKAB high or low		25		38		31	ns
t_{su} Setup time, A before CLKAB \uparrow or B before CLKBA \uparrow		12		18		15	ns
t_h Hold time, A after CLKAB \uparrow or B after CLKBA \uparrow		5		5		5	ns

CD54HC646, CD74HCT646
OCTAL BUS TRANSCEIVERS AND REGISTERS
WITH 3-STATE OUTPUTS

SCHS278B – APRIL 2003 – REVISED APRIL 2003

switching characteristics for CD54HC646 over recommended operating free-air temperature range (unless otherwise noted) (see Figure 2)

PARAMETER	FROM (INPUT)	TO (OUTPUT)	LOAD CAPACITANCE	V _{CC}	T _A = 25°C			T _A = -55°C TO 125°C		T _A = -40°C TO 85°C		UNIT	
					MIN	TYP	MAX	MIN	MAX	MIN	MAX		
f _{max}			C _L = 50 pF	2 V	6			4		5	MHz		
				4.5 V	30			20		25			
				6 V	35			23		29			
			C _L = 15 pF	5 V	60								
t _{pd}	CLKBA or CLKAB	A or B	C _L = 50 pF	2 V		220		330		275	ns		
				4.5 V		44		66		55			
				6 V		37		56		47			
			C _L = 15 pF	5 V	18								
	A or B	B or A	C _L = 50 pF	2 V		135		205		170			
				4.5 V		27		41		34			
				6 V		23		35		29			
			C _L = 15 pF	5 V	12								
			SBA or SAB†	A or B	C _L = 50 pF	2 V		170		255			215
						4.5 V		34		51			43
	6 V					29		43		37			
	C _L = 15 pF	5 V			14								
t _{en}	$\overline{\text{OE}}$	A or B	C _L = 50 pF	2 V		175		265		220			
				4.5 V		35		53		44			
				6 V		30		45		37			
			C _L = 15 pF	5 V	14								
t _{dis}	$\overline{\text{OE}}$	A or B	C _L = 50 pF	2 V		175		265		220			
				4.5 V		35		53		44			
				6 V		30		45		37			
			C _L = 15 pF	5 V	14								
t _t		Any	C _L = 50 pF	2 V		60		90		75			
				4.5 V		12		18		15			
				6 V		10		15		13			

† These parameters are measured with the internal output state of the storage register opposite that of the bus input.



CD54HC646, CD74HCT646
OCTAL BUS TRANSCEIVERS AND REGISTERS
WITH 3-STATE OUTPUTS

SCHS278B – APRIL 2003 – REVISED APRIL 2003

switching characteristics for CD74HCT646 over recommended operating free-air temperature range (unless otherwise noted) (see Figure 3)

PARAMETER	FROM (INPUT)	TO (OUTPUT)	LOAD CAPACITANCE	V _{CC}	T _A = 25°C			T _A = -55°C TO 125°C		T _A = -40°C TO 85°C		UNIT
					MIN	TYP	MAX	MIN	MAX	MIN	MAX	
f _{max}			C _L = 50 pF	4.5 V	25			17		20	MHz	
			C _L = 15 pF	5 V		45						
t _{pd}	CLKBA or CLKAB	A or B	C _L = 50 pF	4.5 V				66		55	ns	
			C _L = 15 pF	5 V		18						
	A or B	B or A	C _L = 50 pF	4.5 V			37		56	46		
			C _L = 15 pF	5 V		15						
	SBA or SAB†	A or B	C _L = 50 pF	4.5 V			46		69	58		
			C _L = 15 pF	5 V		19						
t _{en}	\overline{OE}	A or B	C _L = 50 pF	4.5 V			45		68	56	ns	
			C _L = 15 pF	5 V		19						
t _{dis}	\overline{OE}	A or B	C _L = 50 pF	4.5 V			35		53	44	ns	
			C _L = 15 pF	5 V		14						
t _t			C _L = 50 pF	4.5 V			12		18	15	ns	

† These parameters are measured with the internal output state of the storage register opposite that of the bus input.

operating characteristics, V_{CC} = 5 V, T_A = 25°C

PARAMETER	TYP	UNIT
C _{pd} Power dissipation capacitance	52	pF

CD54HC646, CD74HCT646 OCTAL BUS TRANSCEIVERS AND REGISTERS WITH 3-STATE OUTPUTS

SCHS278B – APRIL 2003 – REVISED APRIL 2003

PARAMETER MEASUREMENT INFORMATION – CD54HC646

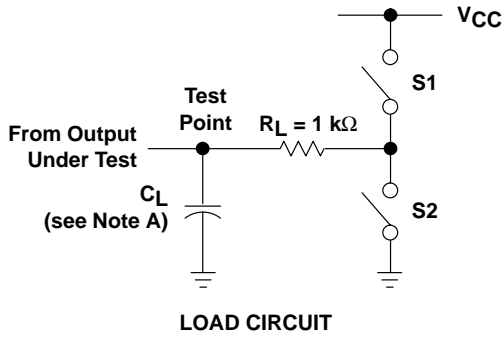

PARAMETER		S1	S2
t_{en}	t_{PZH}	Open	Closed
	t_{PZL}	Closed	Open
t_{dis}	t_{PHZ}	Open	Closed
	t_{PLZ}	Closed	Open
t_{pd} or t_t		Open	Open

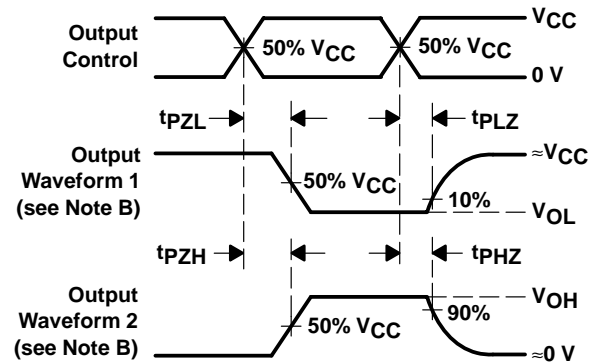
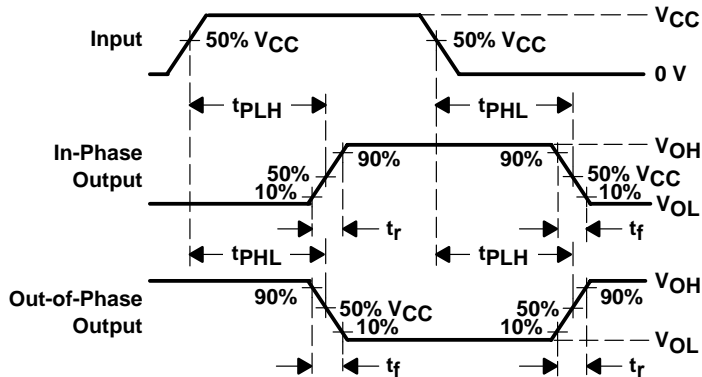
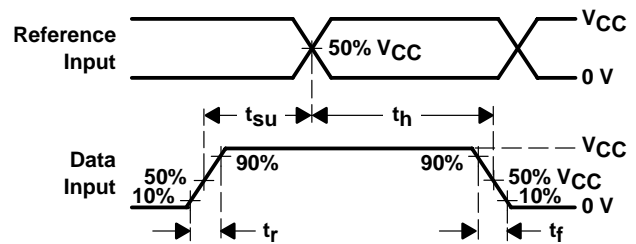
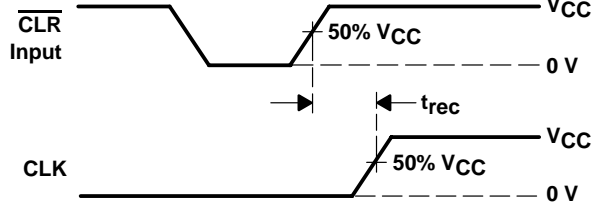
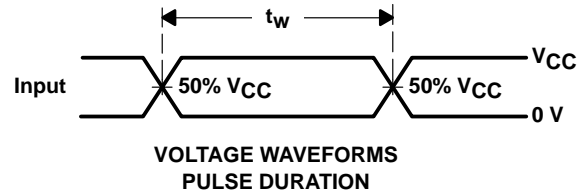

- NOTES: A. C_L includes probe and test-fixture capacitance.
 B. Waveform 1 is for an output with internal conditions such that the output is low except when disabled by the output control. Waveform 2 is for an output with internal conditions such that the output is high except when disabled by the output control.
 C. Phase relationships between waveforms were chosen arbitrarily. All input pulses are supplied by generators having the following characteristics: $PRR \leq 1\text{ MHz}$, $Z_O = 50\ \Omega$, $t_r = 6\text{ ns}$, $t_f = 6\text{ ns}$.
 D. For clock inputs, f_{max} is measured with the input duty cycle at 50%.
 E. The outputs are measured one at a time with one input transition per measurement.
 F. t_{PLZ} and t_{PHZ} are the same as t_{dis} .
 G. t_{PZL} and t_{PZH} are the same as t_{en} .
 H. t_{PLH} and t_{PHL} are the same as t_{pd} .

Figure 2. Load Circuit and Voltage Waveforms

PARAMETER MEASUREMENT INFORMATION – CD74HCT646

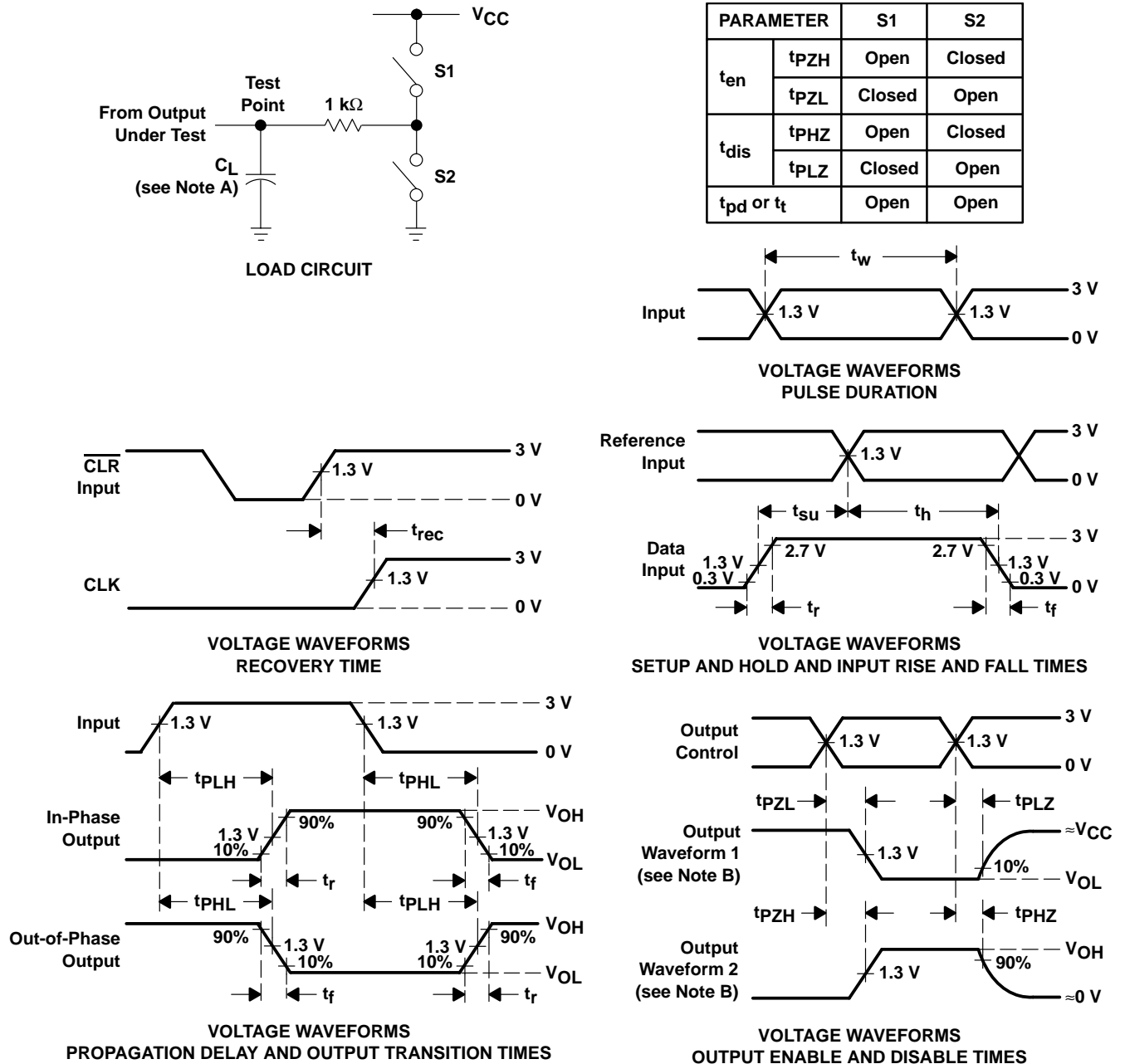

- NOTES:
- A. C_L includes probe and test-fixture capacitance.
 - B. Waveform 1 is for an output with internal conditions such that the output is low except when disabled by the output control. Waveform 2 is for an output with internal conditions such that the output is high except when disabled by the output control.
 - C. Phase relationships between waveforms were chosen arbitrarily. All input pulses are supplied by generators having the following characteristics: $PRR \leq 1$ MHz, $Z_O = 50 \Omega$, $t_r = 6$ ns, $t_f = 6$ ns.
 - D. For clock inputs, f_{max} is measured with the input duty cycle at 50%.
 - E. The outputs are measured one at a time with one input transition per measurement.
 - F. t_{PLZ} and t_{PHZ} are the same as t_{dis} .
 - G. t_{PZL} and t_{PZH} are the same as t_{en} .
 - H. t_{PLH} and t_{PHL} are the same as t_{pd} .

Figure 3. Load Circuit and Voltage Waveforms

PACKAGING INFORMATION

Orderable Device	Status ⁽¹⁾	Package Type	Package Drawing	Pins	Package Qty	Eco Plan ⁽²⁾	Lead/Ball Finish	MSL Peak Temp ⁽³⁾
5962-8688501JA	ACTIVE	CDIP	J	24	1	TBD	A42 SNPB	N / A for Pkg Type
CD54HC646F3A	ACTIVE	CDIP	J	24	1	TBD	A42 SNPB	N / A for Pkg Type
CD74HCT646M96	ACTIVE	SOIC	DW	24	2000	Green (RoHS & no Sb/Br)	CU NIPDAU	Level-1-260C-UNLIM
CD74HCT646M96E4	ACTIVE	SOIC	DW	24	2000	Green (RoHS & no Sb/Br)	CU NIPDAU	Level-1-260C-UNLIM
CD74HCT646M96G4	ACTIVE	SOIC	DW	24	2000	Green (RoHS & no Sb/Br)	CU NIPDAU	Level-1-260C-UNLIM

⁽¹⁾ The marketing status values are defined as follows:

ACTIVE: Product device recommended for new designs.

LIFEBUY: TI has announced that the device will be discontinued, and a lifetime-buy period is in effect.

NRND: Not recommended for new designs. Device is in production to support existing customers, but TI does not recommend using this part in a new design.

PREVIEW: Device has been announced but is not in production. Samples may or may not be available.

OBsolete: TI has discontinued the production of the device.

⁽²⁾ Eco Plan - The planned eco-friendly classification: Pb-Free (RoHS), Pb-Free (RoHS Exempt), or Green (RoHS & no Sb/Br) - please check <http://www.ti.com/productcontent> for the latest availability information and additional product content details.

TBD: The Pb-Free/Green conversion plan has not been defined.

Pb-Free (RoHS): TI's terms "Lead-Free" or "Pb-Free" mean semiconductor products that are compatible with the current RoHS requirements for all 6 substances, including the requirement that lead not exceed 0.1% by weight in homogeneous materials. Where designed to be soldered at high temperatures, TI Pb-Free products are suitable for use in specified lead-free processes.

Pb-Free (RoHS Exempt): This component has a RoHS exemption for either 1) lead-based flip-chip solder bumps used between the die and package, or 2) lead-based die adhesive used between the die and leadframe. The component is otherwise considered Pb-Free (RoHS compatible) as defined above.

Green (RoHS & no Sb/Br): TI defines "Green" to mean Pb-Free (RoHS compatible), and free of Bromine (Br) and Antimony (Sb) based flame retardants (Br or Sb do not exceed 0.1% by weight in homogeneous material)

⁽³⁾ MSL, Peak Temp. -- The Moisture Sensitivity Level rating according to the JEDEC industry standard classifications, and peak solder temperature.

Important Information and Disclaimer:The information provided on this page represents TI's knowledge and belief as of the date that it is provided. TI bases its knowledge and belief on information provided by third parties, and makes no representation or warranty as to the accuracy of such information. Efforts are underway to better integrate information from third parties. TI has taken and continues to take reasonable steps to provide representative and accurate information but may not have conducted destructive testing or chemical analysis on incoming materials and chemicals. TI and TI suppliers consider certain information to be proprietary, and thus CAS numbers and other limited information may not be available for release.

In no event shall TI's liability arising out of such information exceed the total purchase price of the TI part(s) at issue in this document sold by TI to Customer on an annual basis.

TAPE AND REEL INFORMATION



QUADRANT ASSIGNMENTS FOR PIN 1 ORIENTATION IN TAPE



*All dimensions are nominal

Device	Package Type	Package Drawing	Pins	SPQ	Reel Diameter (mm)	Reel Width W1 (mm)	A0 (mm)	B0 (mm)	K0 (mm)	P1 (mm)	W (mm)	Pin1 Quadrant
CD74HCT646M96	SOIC	DW	24	2000	330.0	24.4	10.75	15.7	2.7	12.0	24.0	Q1

TAPE AND REEL BOX DIMENSIONS



*All dimensions are nominal

Device	Package Type	Package Drawing	Pins	SPQ	Length (mm)	Width (mm)	Height (mm)
CD74HCT646M96	SOIC	DW	24	2000	346.0	346.0	41.0

J (R-GDIP-T**)

CERAMIC DUAL-IN-LINE PACKAGE

24 PINS SHOWN

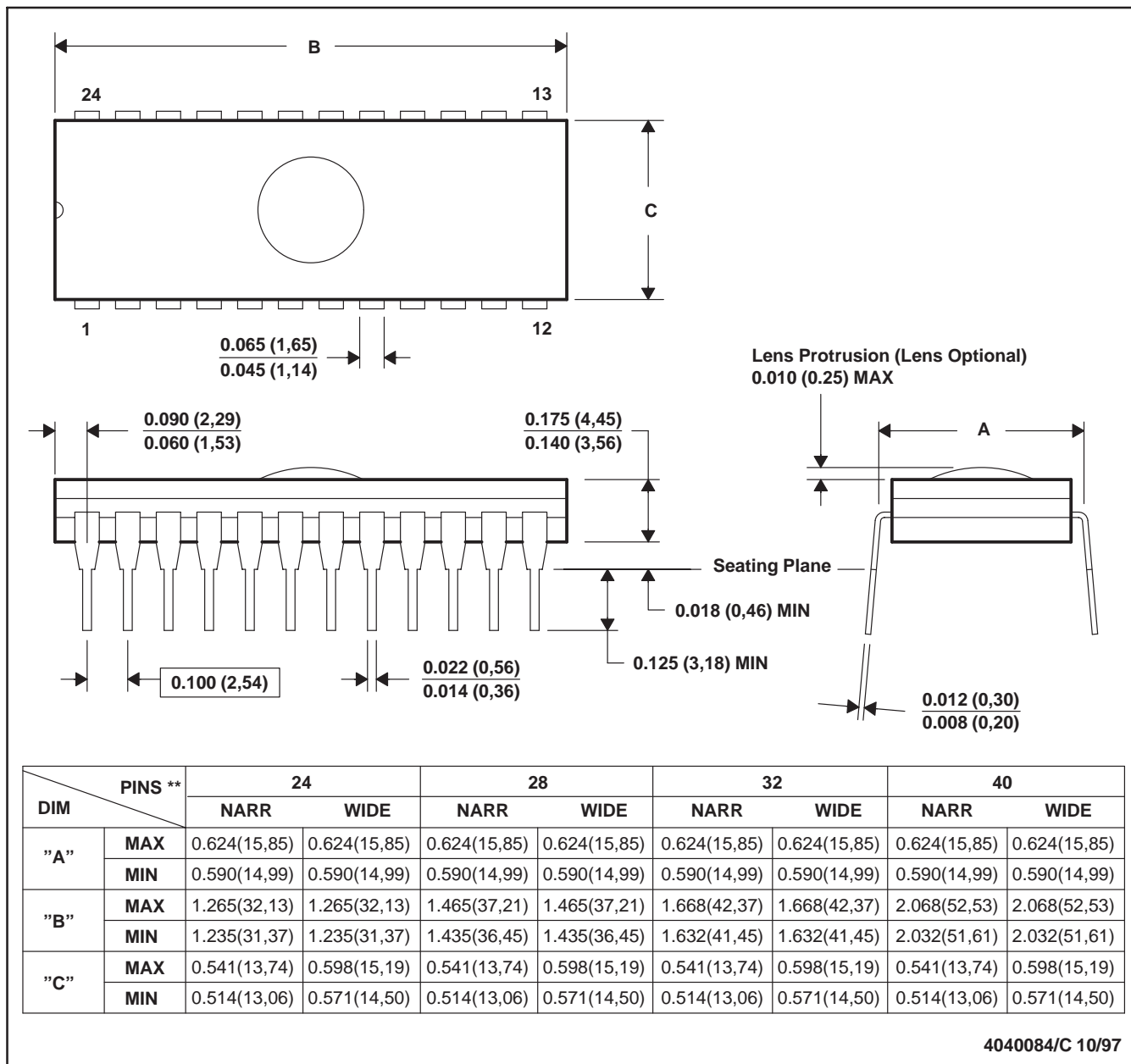

- NOTES: A. All linear dimensions are in inches (millimeters).
 B. This drawing is subject to change without notice.
 C. Window (lens) added to this group of packages (24-, 28-, 32-, 40-pin).
 D. This package can be hermetically sealed with a ceramic lid using glass frit.
 E. Index point is provided on cap for terminal identification.

IMPORTANT NOTICE

Texas Instruments Incorporated and its subsidiaries (TI) reserve the right to make corrections, modifications, enhancements, improvements, and other changes to its products and services at any time and to discontinue any product or service without notice. Customers should obtain the latest relevant information before placing orders and should verify that such information is current and complete. All products are sold subject to TI's terms and conditions of sale supplied at the time of order acknowledgment.

TI warrants performance of its hardware products to the specifications applicable at the time of sale in accordance with TI's standard warranty. Testing and other quality control techniques are used to the extent TI deems necessary to support this warranty. Except where mandated by government requirements, testing of all parameters of each product is not necessarily performed.

TI assumes no liability for applications assistance or customer product design. Customers are responsible for their products and applications using TI components. To minimize the risks associated with customer products and applications, customers should provide adequate design and operating safeguards.

TI does not warrant or represent that any license, either express or implied, is granted under any TI patent right, copyright, mask work right, or other TI intellectual property right relating to any combination, machine, or process in which TI products or services are used. Information published by TI regarding third-party products or services does not constitute a license from TI to use such products or services or a warranty or endorsement thereof. Use of such information may require a license from a third party under the patents or other intellectual property of the third party, or a license from TI under the patents or other intellectual property of TI.

Reproduction of TI information in TI data books or data sheets is permissible only if reproduction is without alteration and is accompanied by all associated warranties, conditions, limitations, and notices. Reproduction of this information with alteration is an unfair and deceptive business practice. TI is not responsible or liable for such altered documentation. Information of third parties may be subject to additional restrictions.

Resale of TI products or services with statements different from or beyond the parameters stated by TI for that product or service voids all express and any implied warranties for the associated TI product or service and is an unfair and deceptive business practice. TI is not responsible or liable for any such statements.

TI products are not authorized for use in safety-critical applications (such as life support) where a failure of the TI product would reasonably be expected to cause severe personal injury or death, unless officers of the parties have executed an agreement specifically governing such use. Buyers represent that they have all necessary expertise in the safety and regulatory ramifications of their applications, and acknowledge and agree that they are solely responsible for all legal, regulatory and safety-related requirements concerning their products and any use of TI products in such safety-critical applications, notwithstanding any applications-related information or support that may be provided by TI. Further, Buyers must fully indemnify TI and its representatives against any damages arising out of the use of TI products in such safety-critical applications.

TI products are neither designed nor intended for use in military/aerospace applications or environments unless the TI products are specifically designated by TI as military-grade or "enhanced plastic." Only products designated by TI as military-grade meet military specifications. Buyers acknowledge and agree that any such use of TI products which TI has not designated as military-grade is solely at the Buyer's risk, and that they are solely responsible for compliance with all legal and regulatory requirements in connection with such use.

TI products are neither designed nor intended for use in automotive applications or environments unless the specific TI products are designated by TI as compliant with ISO/TS 16949 requirements. Buyers acknowledge and agree that, if they use any non-designated products in automotive applications, TI will not be responsible for any failure to meet such requirements.

Following are URLs where you can obtain information on other Texas Instruments products and application solutions:

Products

Amplifiers	amplifier.ti.com
Data Converters	dataconverter.ti.com
DSP	dsp.ti.com
Clocks and Timers	www.ti.com/clocks
Interface	interface.ti.com
Logic	logic.ti.com
Power Mgmt	power.ti.com
Microcontrollers	microcontroller.ti.com
RFID	www.ti-rfid.com
RF/IF and ZigBee® Solutions	www.ti.com/lprf

Applications

Audio	www.ti.com/audio
Automotive	www.ti.com/automotive
Broadband	www.ti.com/broadband
Digital Control	www.ti.com/digitalcontrol
Medical	www.ti.com/medical
Military	www.ti.com/military
Optical Networking	www.ti.com/opticalnetwork
Security	www.ti.com/security
Telephony	www.ti.com/telephony
Video & Imaging	www.ti.com/video
Wireless	www.ti.com/wireless

Mailing Address: Texas Instruments, Post Office Box 655303, Dallas, Texas 75265
Copyright © 2008, Texas Instruments Incorporated