

High-Speed CMOS Logic 14-Stage Binary Counter with Oscillator

Features

- Onboard Oscillator
- Common Reset
- Negative-Edge Clocking
- Fanout (Over Temperature Range)
 - Standard Outputs 10 LSTTL Loads
 - Bus Driver Outputs 15 LSTTL Loads
- Wide Operating Temperature Range . . . -55°C to 125°C
- Balanced Propagation Delay and Transition Times
- Significant Power Reduction Compared to LSTTL Logic ICs
- HC Types
 - 2V to 6V Operation
 - High Noise Immunity: $N_{IL} = 30\%$, $N_{IH} = 30\%$ of V_{CC} at $V_{CC} = 5V$
- HCT Types
 - 4.5V to 5.5V Operation
 - Direct LSTTL Input Logic Compatibility, $V_{IL} = 0.8V$ (Max), $V_{IH} = 2V$ (Min)
 - CMOS Input Compatibility, $I_I \leq 1\mu A$ at V_{OL} , V_{OH}

the negative transition of ϕI (and ϕO). All inputs and outputs are buffered. Schmitt trigger action on the input-pulse-line permits unlimited rise and fall times.

In order to achieve a symmetrical waveform in the oscillator section the HCT4060 input pulse switch points are the same as in the HC4060; only the MR input in the HCT4060 has TTL switching levels.

Ordering Information

PART NUMBER	TEMP. RANGE (°C)	PACKAGE
CD54HC4060F3A	-55 to 125	16 Ld CERDIP
CD54HCT4060F3A	-55 to 125	16 Ld CERDIP
CD74HC4060E	-55 to 125	16 Ld PDIP
CD74HC4060M	-55 to 125	16 Ld SOIC
CD74HC4060MT	-55 to 125	16 Ld SOIC
CD74HC4060M96	-55 to 125	16 Ld SOIC
CD74HC4060PW	-55 to 125	16 Ld TSSOP
CD74HC4060PWR	-55 to 125	16 Ld TSSOP
CD74HC4060PWT	-55 to 125	16 Ld TSSOP
CD74HCT4060E	-55 to 125	16 Ld PDIP
CD74HCT4060M	-55 to 125	16 Ld SOIC
CD74HCT4060MT	-55 to 125	16 Ld SOIC
CD74HCT4060M96	-55 to 125	16 Ld SOIC

Description

The 'HC4060 and 'HCT4060 each consist of an oscillator section and 14 ripple-carry binary counter stages. The oscillator configuration allows design of either RC or crystal oscillator circuits. A Master Reset input is provided which resets the counter to the all-0's state and disables the oscillator. A high level on the MR line accomplishes the reset function. All counter stages are master-slave flip-flops. The state of the counter is advanced one step in binary order on

NOTE: When ordering, use the entire part number. The suffixes 96 and R denote tape and reel. The suffix T denotes a small-quantity reel of 250.

Pinout

CD54HC4060, CD54HCT4060 (CERDIP)
CD74HC4060 (PDIP, SOIC, TSSOP)
CD74HCT4060 (PDIP, SOIC)
TOP VIEW

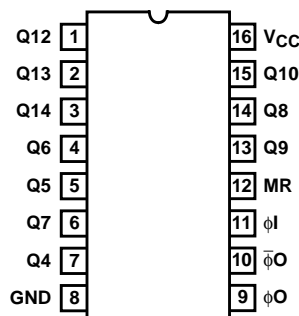

Functional Diagram

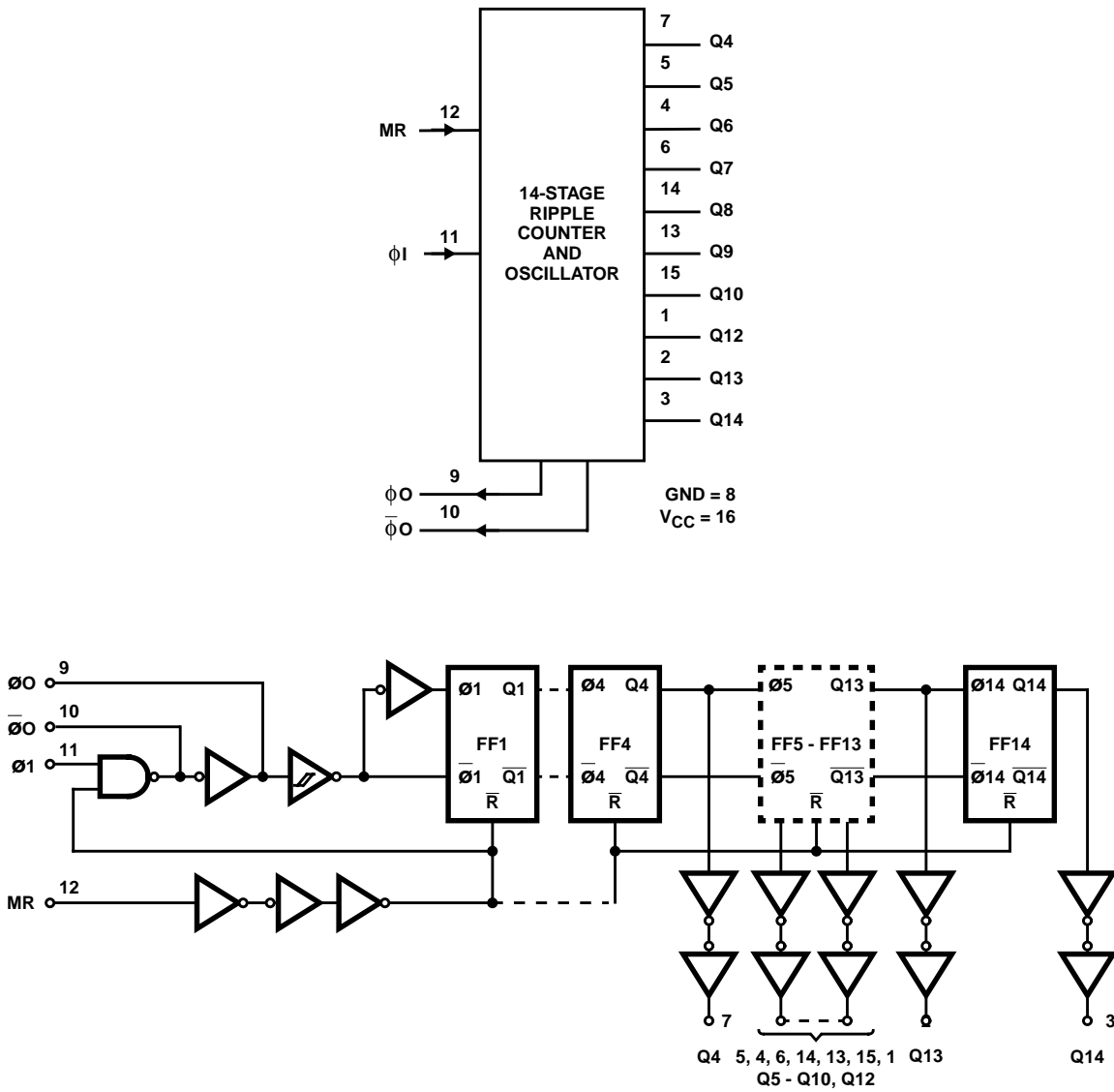

FIGURE 1. LOGIC BLOCK DIAGRAM

TRUTH TABLE

$\phi 1$	MR	OUTPUT STATE
\uparrow	L	No Change
\downarrow	L	Advance to Next State
X	H	All Outputs are Low

CD54/74HC4060, CD54/74HCT4060

Absolute Maximum Ratings

DC Supply Voltage, V_{CC}	-0.5V to 7V
DC Input Diode Current, I_{IK}	
For $V_I < -0.5V$ or $V_I > V_{CC} + 0.5V$	$\pm 20mA$
DC Output Diode Current, I_{OK}	
For $V_O < -0.5V$ or $V_O > V_{CC} + 0.5V$	$\pm 20mA$
DC Drain Current, per Output, I_O	
For $-0.5V < V_O < V_{CC} + 0.5V$	$\pm 25mA$
DC V_{CC} or Ground Current, I_{CC}	$\pm 50mA$

Thermal Information

Thermal Resistance (Typical, Note 1)	θ_{JA} (°C/W)
E (PDIP) Package	67
M (SOIC) Package	73
PW (TSSOP) Package	108
Maximum Junction Temperature	150°C
Maximum Storage Temperature Range	-65°C to 150°C
Maximum Lead Temperature (Soldering 10s)	300°C
(SOIC - Lead Tips Only)	

Operating Conditions

Temperature Range, T_A	-55°C to 125°C
Supply Voltage Range, V_{CC}	
HC Types2V to 6V
HCT Types4.5V to 5.5V
DC Input or Output Voltage, V_I, V_O	0V to V_{CC}
Input Rise and Fall Time	
2V	1000ns (Max)
4.5V	500ns (Max)
6V	400ns (Max)

CAUTION: Stresses above those listed in "Absolute Maximum Ratings" may cause permanent damage to the device. This is a stress only rating and operation of the device at these or any other conditions above those indicated in the operational sections of this specification is not implied.

NOTE:

1. The package thermal impedance is calculated in accordance with JESD 51-7.

DC Electrical Specifications

PARAMETER	SYMBOL	TEST CONDITIONS		V_{CC} (V)	25°C			-40°C TO 85°C		-55°C TO 125°C		UNITS
		V_I (V)	I_O (mA)		MIN	TYP	MAX	MIN	MAX	MIN	MAX	
HC TYPES												
High Level Input Voltage	V_{IH}	-	-	2	1.5	-	-	1.5	-	1.5	-	V
				4.5	3.15	-	-	3.15	-	3.15	-	V
				6	4.2	-	-	4.2	-	4.2	-	V
Low Level Input Voltage	V_{IL}	-	-	2	-	-	0.5	-	0.5	-	0.5	V
				4.5	-	-	1.35	-	1.35	-	1.35	V
				6	-	-	1.8	-	1.8	-	1.8	V
High Level Output Voltage Q Outputs CMOS Loads	V_{OH}	V_{IH} or V_{IL}	-0.02	2	1.9	-	-	1.9	-	1.9	-	V
			-0.02	4.5	4.4	-	-	4.4	-	4.4	-	V
			-0.02	6	5.9	-	-	5.9	-	5.9	-	V
High Level Output Voltage Q Outputs TTL Loads	V_{OH}	V_{IH} or V_{IL}	-	-	-	-	-	-	-	-	-	V
			-4	4.5	3.98	-	-	3.84	-	3.7	-	V
			-5.2	6	5.48	-	-	5.34	-	5.2	-	V
Low Level Output Voltage Q Outputs CMOS Loads	V_{OL}	V_{IH} or V_{IL}	0.02	2	-	-	0.1	-	0.1	-	0.1	V
			0.02	4.5	-	-	0.1	-	0.1	-	0.1	V
			0.02	6	-	-	0.1	-	0.1	-	0.1	V
Low Level Output Voltage Q Outputs TTL Loads	V_{OL}	V_{IH} or V_{IL}	-	-	-	-	-	-	-	-	-	V
			4	4.5	-	-	0.26	-	0.33	-	0.4	V
			5.2	6	-	-	0.26	-	0.33	-	0.4	V
High-Level Output Voltage ϕO Output (Pin 10) CMOS Loads	V_{OH}	V_{CC} or GND	-0.02	2	1.9	-	-	1.9	-	1.9	-	V
			-0.02	4.5	4.4	-	-	4.4	-	4.4	-	V
			-0.02	6	5.9	-	-	5.9	-	5.9	-	V

CD54/74HC4060, CD54/74HCT4060

DC Electrical Specifications (Continued)

PARAMETER	SYMBOL	TEST CONDITIONS		V _{CC} (V)	25°C			-40°C TO 85°C		-55°C TO 125°C		UNITS
		V _I (V)	I _O (mA)		MIN	TYP	MAX	MIN	MAX	MIN	MAX	
High-Level Output Voltage $\bar{\phi}$ O Output (Pin 10) TTL Loads (Note 2)	V _{OH}	V _{CC} or GND	-2.6	4.5	3.98	-	-	3.84	-	3.7	-	V
			-3.3	6	5.48	-	-	5.34	-	5.2	-	V
Low-Level Output Voltage $\bar{\phi}$ O Output (Pin 10) CMOS Loads	V _{OL}	V _{CC} or GND	0.02	2	-	-	0.1	-	0.1	-	0.1	V
			0.02	4.5	-	-	0.1	-	0.1	-	0.1	V
			0.02	6	-	-	0.1	-	0.1	-	0.1	V
Low-Level Output Voltage $\bar{\phi}$ O Output (Pin 10) TTL Loads	V _{OL}	V _{CC} or GND	2.6	4.5	-	-	0.26	-	0.33	-	0.4	V
			3.3	6	-	-	0.26	-	0.33	-	0.4	V
High-Level Output Voltage ϕ O Output (Pin 9) TTL Loads	V _{OH}	V _{IL} or V _{IH}	-3.2	4.5	3.98	-	-	3.84	-	3.7	-	V
			-4.2	6	5.48	-	-	5.34	-	5.2	-	V
Low-Level Output Voltage ϕ O Output (Pin 9) TTL Loads	V _{OL}	V _{IL} or V _{IH}	-2.6	4.5	-	-	0.26	-	0.33	-	0.4	V
			-3.3	6	-	-	0.26	-	0.33	-	0.4	V
Input Leakage Current	I _I	V _{CC} or GND	-	6	-	-	±0.1	-	±1	-	±1	µA
Quiescent Device Current	I _{CC}	V _{CC} or GND	0	6	-	-	8	-	80	-	160	µA
HCT TYPES												
High Level Input Voltage	V _{IH}	-	-	4.5 to 5.5	2	-	-	2	-	2	-	V
Low Level Input Voltage	V _{IL}	-	-	4.5 to 5.5	-	-	0.8	-	0.8	-	0.8	V
High Level Output Voltage Q Outputs CMOS Loads	V _{OH}	V _{IH} or V _{IL} (Note 3)	-0.02	4.5	4.4	-	-	4.4	-	4.4	-	V
High Level Output Voltage Q Outputs TTL Loads			-4	4.5	3.98	-	-	3.84	-	3.7	-	V
Low Level Output Voltage Q Outputs CMOS Loads	V _{OL}	V _{IH} or V _{IL} (Note 3)	0.02	4.5	-	-	0.1	-	0.1	-	0.1	V
Low Level Output Voltage Q Outputs TTL Loads			4	4.5	-	-	0.26	-	0.33	-	0.4	V
High-Level Output Voltage $\bar{\phi}$ O Output (Pin 10) CMOS Loads	V _{OH}	V _{CC} or GND	-0.02	4.5	4.4	-	-	4.4	-	4.4	-	V
High-Level Output Voltage $\bar{\phi}$ O Output (Pin 10) TTL Loads (Note 2)	V _{OH}	V _{CC} or GND	-2.6	4.5	3.98	-	-	3.84	-	3.7	-	V
Low-Level Output Voltage $\bar{\phi}$ O Output (Pin 10) CMOS Loads	V _{OL}	V _{CC} or GND	0.02	4.5	-	-	0.1	-	0.1	-	0.1	V

CD54/74HC4060, CD54/74HCT4060

DC Electrical Specifications (Continued)

PARAMETER	SYMBOL	TEST CONDITIONS		V _{CC} (V)	25°C			-40°C TO 85°C		-55°C TO 125°C		UNITS
		V _I (V)	I _O (mA)		MIN	TYP	MAX	MIN	MAX	MIN	MAX	
Low-Level Output Voltage ϕ O Output (Pin 10) TTL Loads	V _{OL}	V _{CC} or GND	2.6	4.5	-	-	0.26	-	0.33	-	0.4	V
High-Level Output Voltage ϕ O Output (Pin 9) TTL Loads	V _{OH}	V _{IL} or V _{IH}	-3.2	4.5	3.98	-	-	3.84	-	3.7	-	V
Low-Level Output Voltage ϕ O Output (Pin 9) TTL Loads	V _{OL}	V _{IH} or V _{IL} (Note 3)	3.2	4.5	-	-	0.26	-	0.33	-	0.4	V
Input Leakage Current	I _I	Any Voltage Between V _{CC} and GND	-	5.5	-	-	±0.1	-	±1	-	±1	μA
Quiescent Device Current	I _{CC}	V _{CC} or GND	0	5.5	-	-	8	-	80	-	160	μA
Additional Quiescent Device Current Per Input Pin: 1 Unit Load	ΔI _{CC} (Note 4)	V _{CC} - 2.1	-	4.5 to 5.5	-	100	360	-	450	-	490	μA

NOTES:

2. Limits not valid when pin 12 (instead of pin 11) is used as control input.
3. For pin 11 V_{IH} = 3.15V, V_{IL} = 0.9V.
4. For dual-supply systems theoretical worst case (V_I = 2.4V, V_{CC} = 5.5V) specification is 1.8mA.

HCT Input Loading Table

INPUT	UNIT LOADS
MR	0.35

NOTE: Unit Load is ΔI_{CC} limit specified in DC Electrical Specifications Table, e.g. 360μA max at 25°C.

Prerequisite for Switching Specifications

PARAMETER	SYMBOL	V _{CC} (V)	25°C			-40°C TO 85°C			-55°C TO 125°C			UNITS
			MIN	TYP	MAX	MIN	TYP	MAX	MIN	TYP	MAX	
HC TYPES												
Maximum Input Pulse Frequency	f _{max}	2	6	-	-	5	-	-	4	-	-	MHz
		4.5	30	-	-	25	-	-	20	-	-	MHz
		6	35	-	-	29	-	-	23	-	-	MHz
Input Pulse Width	t _W	2	80	-	-	100	-	-	120	-	-	ns
		4.5	16	-	-	20	-	-	24	-	-	ns
		6	14	-	-	17	-	-	20	-	-	ns
Reset Removal Time	t _{REM}	2	100	-	-	125	-	-	150	-	-	ns
		4.5	20	-	-	25	-	-	30	-	-	ns
		6	17	-	-	21	-	-	26	-	-	ns

CD54/74HC4060, CD54/74HCT4060

Prerequisite for Switching Specifications (Continued)

PARAMETER	SYMBOL	V _{CC} (V)	25°C			-40°C TO 85°C			-55°C TO 125°C			UNITS
			MIN	TYP	MAX	MIN	TYP	MAX	MIN	TYP	MAX	
Reset Pulse Width	t _W	2	80	-	-	100	-	-	120	-	-	ns
		4.5	16	-	-	20	-	-	24	-	-	ns
		6	14	-	-	17	-	-	20	-	-	ns
HCT TYPES												
Maximum Input, Pulse Frequency	f _{max}	4.5	30	-	-	25	-	-	20	-	-	MHz
Input Pulse Width	t _W	4.5	16	-	-	20	-	-	24	-	-	ns
Reset Removal Time	t _{REM}	4.5	26	-	-	33	-	-	39	-	-	ns
Reset Pulse Width	t _W	4.5	25	-	-	31	-	-	38	-	-	ns

Switching Specifications Input t_r, t_f = 6ns

PARAMETER	SYMBOL	TEST CONDITIONS	V _{CC} (V)	25°C			-40°C TO 85°C		-55°C TO 125°C		UNITS
				MIN	TYP	MAX	MIN	MAX	MIN	MAX	
HC TYPES											
Propagation Delay φI to Q4	t _{PLH} , t _{PHL}	C _L = 50pF	2	-	-	300	-	375	-	450	ns
			4.5	-	-	60	-	75	-	90	ns
		C _L = 15pF	5	-	25	-	-	-	-	-	ns
		C _L = 50pF	6	-	-	51	-	64	-	78	ns
Q _n to Q _{n+1}	t _{PLH} , t _{PHL}	C _L = 50pF	2	-	-	80	-	100	-	120	ns
			4.5	-	-	16	-	20	-	24	ns
		C _L = 15pF	5	-	6	-	-	-	-	-	ns
		C _L = 50pF	6	-	-	14	-	17	-	20	ns
MR to Q _n	t _{PHL}	C _L = 50pF	2	-	-	175	-	220	-	265	ns
			4.5	-	-	35	-	44	-	53	ns
		C _L = 15pF	5	-	14	-	-	-	-	-	ns
		C _L = 50pF	6	-	-	30	-	37	-	45	ns
Output Transition Time	t _{THL} , t _{TLH}	C _L = 50pF	2	-	-	75	-	95	-	110	ns
			4.5	-	-	15	-	19	-	22	ns
			6	-	-	13	-	16	-	19	ns
Input Capacitance	C _I (TBD)										
Propagation Dissipation Capacitance (Notes 5, 6)	C _{PD}	-	-	-	40	-	-	-	-	-	pF
HCT TYPES											
Propagation Delay φI to Q4	t _{PLH} , t _{PHL}	C _L = 50pF	2	-	-	-	-	-	-	-	-ns
			4.5	-	-	66	-	83	-	100	ns
		C _L = 15pF	5	-	25	-	-	-	-	-	-ns
		C _L = 50pF	6	-	-	-	-	-	-	-	-ns

CD54/74HC4060, CD54/74HCT4060

Switching Specifications Input $t_r, t_f = 6\text{ns}$ (Continued)

PARAMETER	SYMBOL	TEST CONDITIONS	V_{CC} (V)	25°C			-40°C TO 85°C		-55°C TO 125°C		UNITS
				MIN	TYP	MAX	MIN	MAX	MIN	MAX	
Q_n to Q_{n+1}	t_{PLH}, t_{PHL}	$C_L = 50\text{pF}$	2	-	-	-	-	-	-	-	ns
			4.5	-	-	16	-	20	-	24	ns
		$C_L = 15\text{pF}$	5	-	6	-	-	-	-	-	ns
		$C_L = 50\text{pF}$	6	-	-	-	-	-	-	-	ns
MR to Q_n	t_{PHL}	$C_L = 50\text{pF}$	2	-	-	-	-	-	-	-	ns
			4.5	-	-	44	-	55	-	66	ns
		$C_L = 15\text{pF}$	5	-	17	-	-	-	-	-	ns
		$C_L = 50\text{pF}$	6	-	-	-	-	-	-	-	ns
Output Transition Time	t_{THL}, t_{TLH}	$C_L = 50\text{pF}$	2	-	-	-	-	-	-	-	ns
			4.5	-	-	15	-	19	-	22	ns
			6	-	-	-	-	-	-	-	ns
Input Capacitance	C_I (TBD)										
Propagation Dissipation Capacitance (Notes 5, 6)	C_{PD}	-	-	-	40	-	-	-	-	-	pF

NOTES:

- C_{PD} is used to determine the dynamic power consumption, per package.
- $P_D = C_{PD} V_{CC}^2 f_i \sum (C_L V_{CC}^2 f_i / M)$ where $M = 2^1, 2^2, 2^3, \dots, 2^{14}$, f_i = input frequency, C_L = output load capacitance.

TYPICAL LIMIT VALUES FOR R_X AND C_X

PARAMETER	TEST CONDITIONS	VOLTAGE	TYPICAL MAXIMUM LIMITS
R_X Minimum	$C_X > 1000\text{pF}$	2	1K Ω
	$C_X > 10\text{pF}$	4.5	
	$C_X > 10\text{pF}$	6	
R_X Maximum	$C_X > 10\text{pF}$	2	20M Ω
	$C_X > 10\text{pF}$	4.5	
	$C_X > 10\text{pF}$	6	
C_X Minimum	$R_X > 10\text{K}\Omega$	2	10pF
	$R_X > 10\text{K}\Omega$	4.5	
	$R_X > 10\text{K}\Omega$	6	
	$R_X = 1\text{K}\Omega$	2	1000pF
	$R_X = 1\text{K}\Omega$	4.5	10pF
	$R_X = 1\text{K}\Omega$	6	10pF
Maximum Astable Oscillator Frequency	$C_X = 1000\text{pF}$, $R_X = 1\text{K}\Omega$	2	0.5MHz (Note 7)
	$C_X = 100\text{pF}$, $R_X = 1\text{K}\Omega$	4.5	3MHz (Note 7)
	$C_X = 100\text{pF}$, $R_X = 1\text{K}\Omega$	6	3MHz (Note 7)

NOTE:

- At very high frequencies $f = 1/2.2 R_X C_X$ no longer gives an accurate approximation.

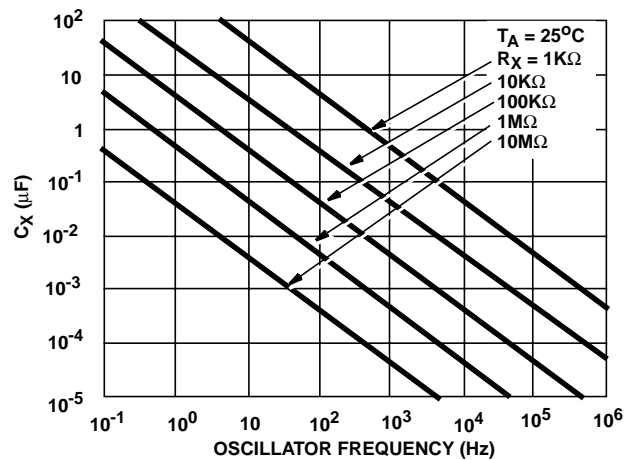

NOTE: OSC Frequency $\approx 1/2.2 R_X C_X$
For $1\text{M}\Omega > R_X > 1\text{K}\Omega$, $C_X > 10\text{pF}$, $f < 1\text{MHz}$

FIGURE 2. FREQUENCY OF ON-BOARD OSCILLATOR AS A FUNCTION OF C_X AND R_X

Typical Performance Curves

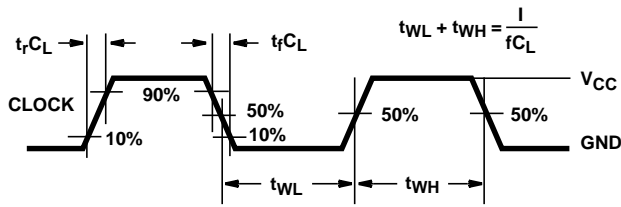

NOTE: Outputs should be switching from 10% V_{CC} to 90% V_{CC} in accordance with device truth table. For f_{MAX} , input duty cycle = 50%.

FIGURE 3. HC CLOCK PULSE RISE AND FALL TIMES AND PULSE WIDTH

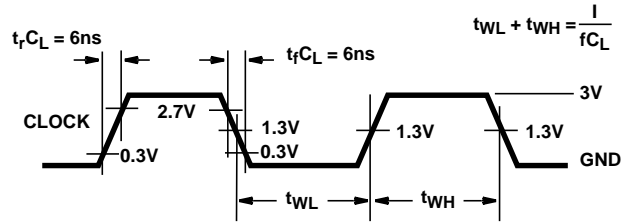

NOTE: Outputs should be switching from 10% V_{CC} to 90% V_{CC} in accordance with device truth table. For f_{MAX} , input duty cycle = 50%.

FIGURE 4. HCT CLOCK PULSE RISE AND FALL TIMES AND PULSE WIDTH

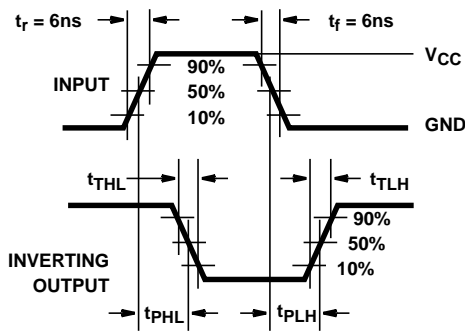

FIGURE 5. HC AND HCT TRANSITION TIMES AND PROPAGATION DELAY TIMES, COMBINATION LOGIC

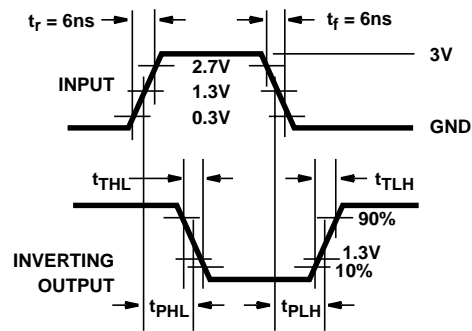
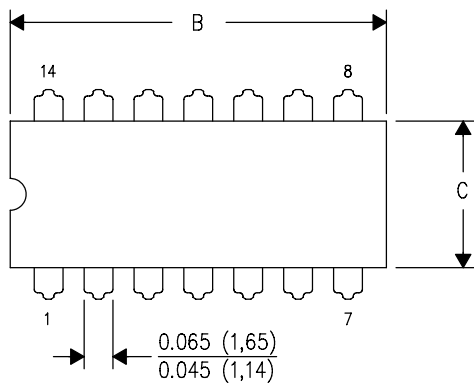

FIGURE 6. HCT TRANSITION TIMES AND PROPAGATION DELAY TIMES, COMBINATION LOGIC

J (R-GDIP-T**)

14 LEADS SHOWN

CERAMIC DUAL IN-LINE PACKAGE



DIM \ PINS **	14	16	18	20
A	0.300 (7,62) BSC	0.300 (7,62) BSC	0.300 (7,62) BSC	0.300 (7,62) BSC
B MAX	0.785 (19,94)	.840 (21,34)	0.960 (24,38)	1.060 (26,92)
B MIN	—	—	—	—
C MAX	0.300 (7,62)	0.300 (7,62)	0.310 (7,87)	0.300 (7,62)
C MIN	0.245 (6,22)	0.245 (6,22)	0.220 (5,59)	0.245 (6,22)



4040083/F 03/03

- NOTES:
- All linear dimensions are in inches (millimeters).
 - This drawing is subject to change without notice.
 - This package is hermetically sealed with a ceramic lid using glass frit.
 - Index point is provided on cap for terminal identification only on press ceramic glass frit seal only.
 - Falls within MIL STD 1835 GDIP1-T14, GDIP1-T16, GDIP1-T18 and GDIP1-T20.

N (R-PDIP-T**)

PLASTIC DUAL-IN-LINE PACKAGE

16 PINS SHOWN

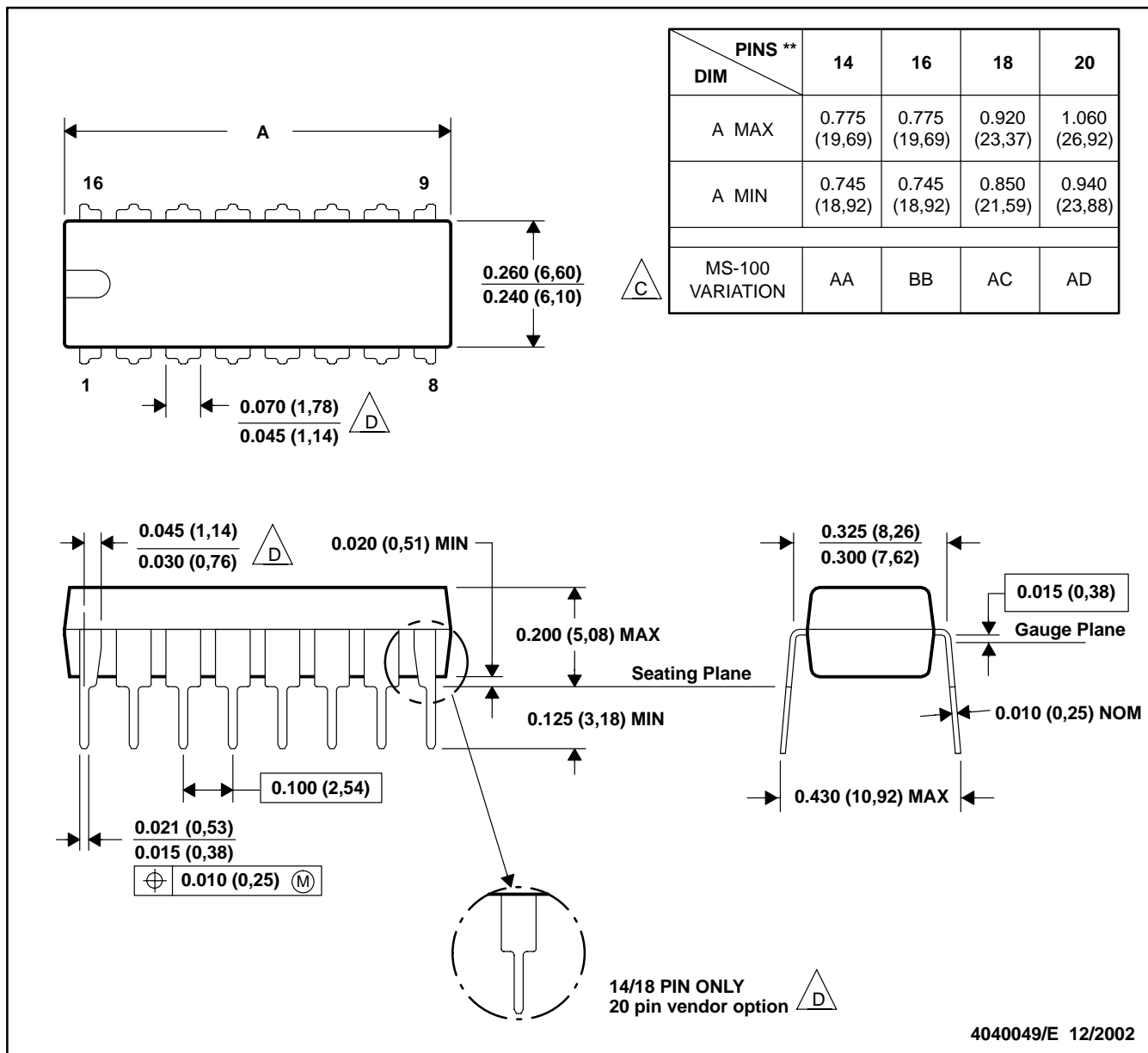

- NOTES: A. All linear dimensions are in inches (millimeters).
 B. This drawing is subject to change without notice.
 C Falls within JEDEC MS-001, except 18 and 20 pin minimum body length (Dim A).
 D The 20 pin end lead shoulder width is a vendor option, either half or full width.

D (R-PDSO-G**)

PLASTIC SMALL-OUTLINE PACKAGE

8 PINS SHOWN

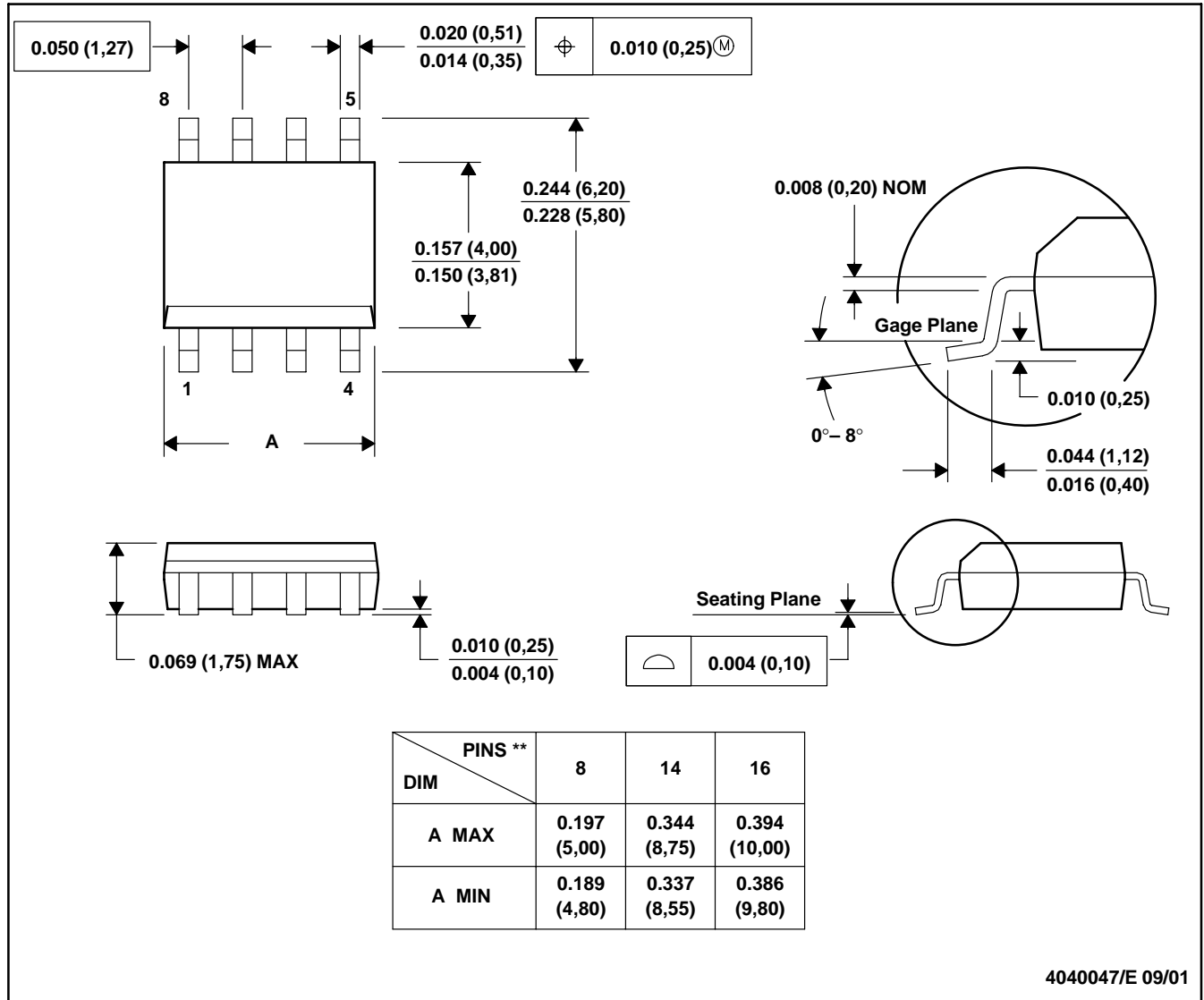

- NOTES: A. All linear dimensions are in inches (millimeters).
 B. This drawing is subject to change without notice.
 C. Body dimensions do not include mold flash or protrusion, not to exceed 0.006 (0,15).
 D. Falls within JEDEC MS-012

PW (R-PDSO-G**)

PLASTIC SMALL-OUTLINE PACKAGE

14 PINS SHOWN



4040064/F 01/97

- NOTES: A. All linear dimensions are in millimeters.
 B. This drawing is subject to change without notice.
 C. Body dimensions do not include mold flash or protrusion not to exceed 0,15.
 D. Falls within JEDEC MO-153

IMPORTANT NOTICE

Texas Instruments Incorporated and its subsidiaries (TI) reserve the right to make corrections, modifications, enhancements, improvements, and other changes to its products and services at any time and to discontinue any product or service without notice. Customers should obtain the latest relevant information before placing orders and should verify that such information is current and complete. All products are sold subject to TI's terms and conditions of sale supplied at the time of order acknowledgment.

TI warrants performance of its hardware products to the specifications applicable at the time of sale in accordance with TI's standard warranty. Testing and other quality control techniques are used to the extent TI deems necessary to support this warranty. Except where mandated by government requirements, testing of all parameters of each product is not necessarily performed.

TI assumes no liability for applications assistance or customer product design. Customers are responsible for their products and applications using TI components. To minimize the risks associated with customer products and applications, customers should provide adequate design and operating safeguards.

TI does not warrant or represent that any license, either express or implied, is granted under any TI patent right, copyright, mask work right, or other TI intellectual property right relating to any combination, machine, or process in which TI products or services are used. Information published by TI regarding third-party products or services does not constitute a license from TI to use such products or services or a warranty or endorsement thereof. Use of such information may require a license from a third party under the patents or other intellectual property of the third party, or a license from TI under the patents or other intellectual property of TI.

Reproduction of information in TI data books or data sheets is permissible only if reproduction is without alteration and is accompanied by all associated warranties, conditions, limitations, and notices. Reproduction of this information with alteration is an unfair and deceptive business practice. TI is not responsible or liable for such altered documentation.

Resale of TI products or services with statements different from or beyond the parameters stated by TI for that product or service voids all express and any implied warranties for the associated TI product or service and is an unfair and deceptive business practice. TI is not responsible or liable for any such statements.

Following are URLs where you can obtain information on other Texas Instruments products and application solutions:

Products		Applications	
Amplifiers	amplifier.ti.com	Audio	www.ti.com/audio
Data Converters	dataconverter.ti.com	Automotive	www.ti.com/automotive
DSP	dsp.ti.com	Broadband	www.ti.com/broadband
Interface	interface.ti.com	Digital Control	www.ti.com/digitalcontrol
Logic	logic.ti.com	Military	www.ti.com/military
Power Mgmt	power.ti.com	Optical Networking	www.ti.com/opticalnetwork
Microcontrollers	microcontroller.ti.com	Security	www.ti.com/security
		Telephony	www.ti.com/telephony
		Video & Imaging	www.ti.com/video
		Wireless	www.ti.com/wireless

Mailing Address: Texas Instruments
Post Office Box 655303 Dallas, Texas 75265

Copyright © 2003, Texas Instruments Incorporated