

August 1997 - Revised May 2000

## High Speed CMOS Logic Quad 2-Input NAND Schmitt Trigger

### Features

- Unlimited Input Rise and Fall Times
- Exceptionally High Noise Immunity
- Typical Propagation Delay: 10ns at  $V_{CC} = 5V$ ,  $C_L = 15pF$ ,  $T_A = 25^\circ C$
- Fanout (Over Temperature Range)
  - Standard Outputs . . . . . 10 LSTTL Loads
  - Bus Driver Outputs . . . . . 15 LSTTL Loads
- Wide Operating Temperature Range . . .  $-55^\circ C$  to  $125^\circ C$
- Balanced Propagation Delay and Transition Times
- Significant Power Reduction Compared to LSTTL Logic ICs
- HC Types
  - 2V to 6V Operation
  - High Noise Immunity:  $N_{IL} = 37\%$ ,  $N_{IH} = 51\%$  of  $V_{CC}$  at  $V_{CC} = 5V$
- HCT Types
  - 4.5V to 5.5V Operation
  - Direct LSTTL Input Logic Compatibility,  $V_{IL} = 0.8V$  (Max),  $V_{IH} = 2V$  (Min)
  - CMOS Input Compatibility,  $I_I \leq 1\mu A$  at  $V_{OL}$ ,  $V_{OH}$

### Description

The 'HC132 and 'HCT132 each contain four 2-input NAND Schmitt Triggers in one package. This logic device utilizes silicon gate CMOS technology to achieve operating speeds similar to LSTTL gates with the low power consumption of standard CMOS integrated circuits. All devices have the ability to drive 10 LSTTL loads. The HCT logic family is functionally pin compatible with the standard LS logic family.

### Ordering Information

PART NUMBER	TEMP. RANGE (°C)	PACKAGE
CD54HC132F3A	-55 to 125	14 Ld CERDIP
CD74HC132E	-55 to 125	14 Ld PDIP
CD74HC132M	-55 to 125	14 Ld SOIC
CD54HCT132F	-55 to 125	14 Ld CERDIP
CD54HCT132F3A	-55 to 125	14 Ld CERDIP
CD74HCT132E	-55 to 125	14 Ld PDIP
CD74HCT132M	-55 to 125	14 Ld SOIC

#### NOTES:

1. When ordering, use the entire part number. Add the suffix 96 to obtain the variant in the tape and reel.
2. Die for this part number is available which meets all electrical specifications. Please contact your local TI sales office or customer service for ordering information.

### Pinout

CD54HC132, CD54HCT132  
(CERDIP)  
CD74HC132, CD74HCT132  
(PDIP, SOIC)  
TOP VIEW

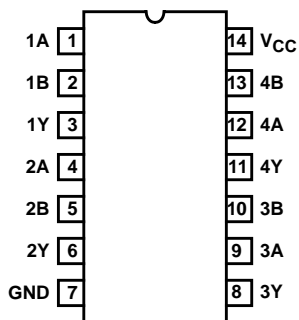

**Functional Diagram**

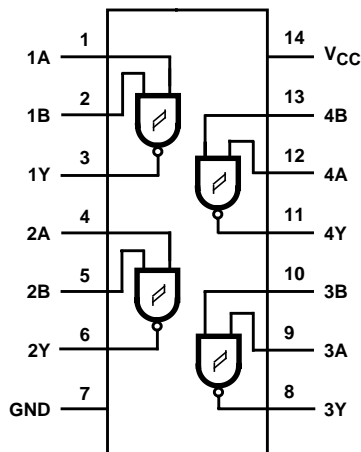

TRUTH TABLE

INPUTS		OUTPUT
nA	nB	nY
L	L	H
L	H	H
H	L	H
H	H	L

NOTE: H = High Voltage Level, L = Low Voltage Level

**Logic Symbol**

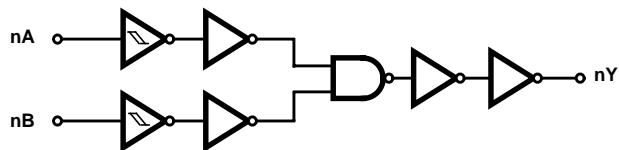

## CD54/74HC132, CD54/74HCT132

### Absolute Maximum Ratings

DC Supply Voltage, $V_{CC}$ .....	-0.5V to 7V
DC Input Diode Current, $I_{IK}$	
For $V_I < -0.5V$ or $V_I > V_{CC} + 0.5V$ .....	$\pm 20mA$
DC Output Diode Current, $I_{OK}$	
For $V_O < -0.5V$ or $V_O > V_{CC} + 0.5V$ .....	$\pm 20mA$
DC Output Source or Sink Current per Output Pin, $I_O$	
For $V_O > -0.5V$ or $V_O < V_{CC} + 0.5V$ .....	$\pm 25mA$
DC $V_{CC}$ or Ground Current, $I_{CC}$ or $I_{GND}$ .....	$\pm 50mA$

### Thermal Information

Thermal Resistance (Typical, Note 3)	$\theta_{JA}$ ( $^{\circ}C/W$ )
PDIP Package .....	90
SOIC Package .....	175
Maximum Junction Temperature .....	$150^{\circ}C$
Maximum Storage Temperature Range .....	$-65^{\circ}C$ to $150^{\circ}C$
Maximum Lead Temperature (Soldering 10s) .....	$300^{\circ}C$ (SOIC - Lead Tips Only)

### Operating Conditions

Temperature Range ( $T_A$ ) .....	$-55^{\circ}C$ to $125^{\circ}C$
Supply Voltage Range, $V_{CC}$	
HC Types .....	.2V to 6V
HCT Types .....	4.5V to 5.5V
DC Input or Output Voltage, $V_I$ , $V_O$ .....	0V to $V_{CC}$
Input Rise and Fall Time	
2V .....	100ms (Max)
4.5V .....	100ms (Max)
6V .....	100ms (Max)

*CAUTION: Stresses above those listed in "Absolute Maximum Ratings" may cause permanent damage to the device. This is a stress only rating and operation of the device at these or any other conditions above those indicated in the operational sections of this specification is not implied.*

#### NOTE:

3.  $\theta_{JA}$  is measured with the component mounted on an evaluation PC board in free air.

### DC Electrical Specifications

PARAMETER	SYMBOL	TEST CONDITIONS		$V_{CC}$ (V)	25°C			-40°C TO 85°C		-55°C TO 125°C		UNITS
		$V_I$ (V)	$I_O$ (mA)		MIN	TYP	MAX	MIN	MAX	MIN	MAX	
<b>HC TYPES</b>												
Input Switch Points (Note 6)	$V_{T+}$	-	-	2	0.7	-	1.5	0.7	1.5	0.7	1.5	V
				4.5	1.7	-	3.15	1.7	3.15	1.7	3.15	V
				6	2.1	-	4.2	2.1	4.2	2.1	4.2	V
	$V_{T-}$	-	-	2	0.3	-	1	0.3	1	0.3	1	V
				4.5	0.9	-	2.2	0.9	2.2	0.9	2.2	V
				6	1.2	-	3	1.2	3	1.2	3	V
	$V_H$			2	0.2	-	1	0.2	1	0.2	1	V
				4.5	0.4	-	1.4	0.4	1.4	0.4	1.4	V
				6	0.6	-	1.6	0.6	1.6	0.6	1.6	V
High Level Output Voltage CMOS Loads	$V_{OH}$	$V_{T+}$ or $V_{T-}$	-0.02	2	1.9	-	-	1.9	-	1.9	-	V
			-0.02	4.5	4.4	-	-	4.4	-	4.4	-	V
			-0.02	6	5.9	-	-	5.9	-	5.9	-	V
High Level Output Voltage TTL Loads	$V_{OH}$	$V_{T+}$ or $V_{T-}$	-4	4.5	3.98	-	-	3.84	-	3.7	-	V
			-5.2	6	5.48	-	-	5.34	-	5.2	-	V

**CD54/74HC132, CD54/74HCT132**

**DC Electrical Specifications (Continued)**

PARAMETER	SYMBOL	TEST CONDITIONS			25°C			-40°C TO 85°C		-55°C TO 125°C		UNITS
		V <sub>I</sub> (V)	I <sub>O</sub> (mA)	V <sub>CC</sub> (V)	MIN	TYP	MAX	MIN	MAX	MIN	MAX	
Low Level Output Voltage CMOS Loads	V <sub>OL</sub>	V <sub>T+</sub> or V <sub>T-</sub>	0.02	2	-	-	0.1	-	0.1	-	0.1	V
			0.02	4.5	-	-	0.1	-	0.1	-	0.1	V
			0.02	6	-	-	0.1	-	0.1	-	0.1	V
			4	4.5	-	-	0.26	-	0.33	-	0.4	V
			5.2	6	-	-	0.26	-	0.33	-	0.4	V
Low Level Output Voltage TTL Loads			4	4.5	-	-	0.26	-	0.33	-	0.4	V
			5.2	6	-	-	0.26	-	0.33	-	0.4	V
Input Leakage Current	I <sub>I</sub>	V <sub>CC</sub> or GND	-	6	-	-	±0.1	-	±1	-	±1	μA
Quiescent Device Current	I <sub>CC</sub>	V <sub>CC</sub> or GND	0	6	-	-	2	-	20	-	40	μA
<b>HCT TYPES</b>												
Input Switch Points (Note 6)	V <sub>T+</sub>	-	-	4.5	1.2	-	1.9	1.2	1.9	1.2	1.9	V
				5.5	1.4	-	2.1	1.4	2.1	1.4	2.1	V
	V <sub>T-</sub>	-	-	4.5	0.5	-	1.2	0.5	1.2	0.5	1.2	V
				5.5	0.6	-	1.4	0.6	1.4	0.6	1.4	V
	V <sub>H</sub>	-	-	4.5	0.4	-	1.4	0.4	1.4	0.4	1.4	V
				5.5	0.4	-	1.5	0.4	1.5	0.4	1.5	V
High Level Output Voltage CMOS Loads	-	V <sub>T+</sub> or V <sub>T-</sub>	-	4.5	4.4	-	-	4.4	-	4.4	-	V
High Level Output Voltage TTL Loads			-	4.5	3.98	-	-	3.84	-	3.7	-	V
Low Level Output Voltage CMOS Loads	V <sub>OL</sub>	V <sub>T+</sub> or V <sub>T-</sub>	-4	4.5	-	-	0.1	-	0.1	-	0.1	V
Low Level Output Voltage TTL Loads			0.02	4.5	-	-	0.26	-	0.33	-	0.4	V
Input Leakage Current	I <sub>I</sub>	V <sub>CC</sub> and GND	4	5.5	-	-	±0.1	-	±1	-	±1	μA
Quiescent Device Current	I <sub>CC</sub>	V <sub>CC</sub> or GND	0	5.5	-	-	2	-	20	-	40	μA
Additional Quiescent Device Current Per Input Pin: 1 Unit Load (Note 4)	ΔI <sub>CC</sub>	V <sub>CC</sub> - 2.1	-	4.5 to 5.5	-	100	360	-	450	-	490	μA

**NOTES:**

- For dual-supply systems theoretical worst case (V<sub>I</sub> = 2.4V, V<sub>CC</sub> = 5.5V) specification is 1.8mA.
- Die for this part number is available which meets all electrical specifications.
- Hysteresis definition, characteristic and test setup see Test Circuits and Waveforms.

**CD54/74HC132, CD54/74HCT132**

**HCT Input Loading Table**

INPUT	UNIT LOADS
nA, nB	0.6

NOTE: Unit Load is  $\Delta I_{CC}$  limit specified in DC Electrical Specifications table, e.g. 360 $\mu$ A max at 25°C.

**Switching Specifications** Input  $t_r$ ,  $t_f$  = 6ns

PARAMETER	SYMBOL	TEST CONDITIONS	V <sub>CC</sub> (V)	25°C			-40°C TO 85°C		-55°C TO 125°C		UNITS
				MIN	TYP	MAX	MIN	MAX	MIN	MAX	
<b>HC TYPES</b>											
Propagation Delay A, B to Y (Figure 1)	t <sub>PLH</sub> , t <sub>PHL</sub>	C <sub>L</sub> = 50pF	2	-	-	125	-	156	-	188	ns
			4.5	-	-	25	-	31	-	38	ns
			6	-	-	21	-	27	-	32	ns
Propagation Delay A, B to Y	t <sub>TLH</sub> , t <sub>THL</sub>	C <sub>L</sub> = 15pF	5	-	10	-	-	-	-	pF	
Transition Times (Figure 1)	t <sub>TLH</sub> , t <sub>THL</sub>	C <sub>L</sub> = 50pF	2	-	-	75	-	95	-	110	ns
			4.5	-	-	15	-	19	-	22	ns
			6	-	-	13	-	16	-	19	ns
Input Capacitance	C <sub>I</sub>	-	-	-	10	-	10	-	10	pF	
Power Dissipation Capacitance (Notes 7, 8)	C <sub>PD</sub>	-	5	-	30	-	-	-	-	pF	
<b>HCT TYPES</b>											
Propagation Delay A, B to Y (Figure 2)	t <sub>PHL</sub> , t <sub>PHL</sub>	C <sub>L</sub> = 50pF	4.5	-	-	33	-	41	-	50	ns
Propagation Delay A, B to Y	t <sub>PLH</sub> , t <sub>PHL</sub>	C <sub>L</sub> = 15pF	5	-	13	-	-	-	-	pF	
Transition Times (Figure 2)	t <sub>TLH</sub> , t <sub>THL</sub>	C <sub>L</sub> = 50pF	4.5	-	-	15	-	19	-	22	ns
Input Capacitance	C <sub>I</sub>	-	-	-	10	-	10	-	10	pF	
Power Dissipation Capacitance (Notes 7, 8)	C <sub>PD</sub>	-	5	-	30	-	-	-	-	pF	

**NOTES:**

7. C<sub>PD</sub> is used to determine the dynamic power consumption, per gate.

8.  $P_D = V_{CC}^2 f_i (C_{PD} + C_L)$  where  $f_i$  = input frequency,  $C_L$  = output load capacitance,  $V_{CC}$  = supply voltage.

Test Circuits and Waveforms

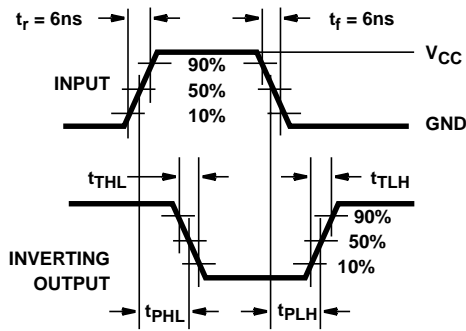

FIGURE 1. HC AND HCU TRANSITION TIMES AND PROPAGATION DELAY TIMES, COMBINATION LOGIC

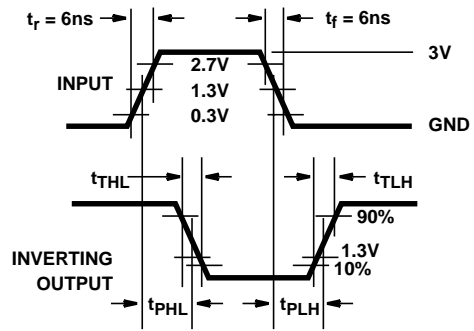

FIGURE 2. HCT TRANSITION TIMES AND PROPAGATION DELAY TIMES, COMBINATION LOGIC

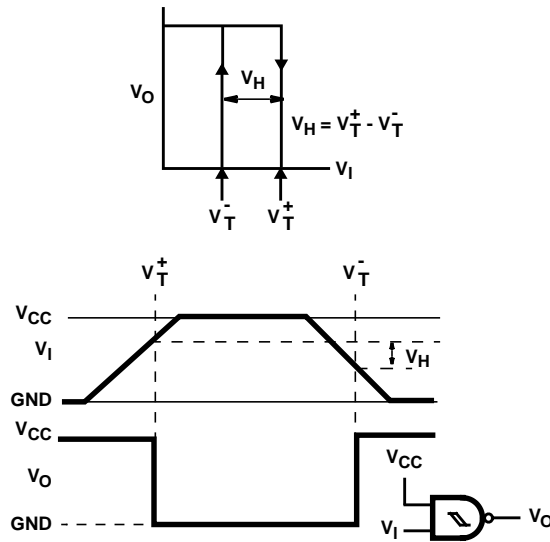

FIGURE 3. HYSTERESIS DEFINITION, CHARACTERISTIC, AND TEST SET-UP

## **IMPORTANT NOTICE**

Texas Instruments and its subsidiaries (TI) reserve the right to make changes to their products or to discontinue any product or service without notice, and advise customers to obtain the latest version of relevant information to verify, before placing orders, that information being relied on is current and complete. All products are sold subject to the terms and conditions of sale supplied at the time of order acknowledgment, including those pertaining to warranty, patent infringement, and limitation of liability.

TI warrants performance of its semiconductor products to the specifications applicable at the time of sale in accordance with TI's standard warranty. Testing and other quality control techniques are utilized to the extent TI deems necessary to support this warranty. Specific testing of all parameters of each device is not necessarily performed, except those mandated by government requirements.

Customers are responsible for their applications using TI components.

In order to minimize risks associated with the customer's applications, adequate design and operating safeguards must be provided by the customer to minimize inherent or procedural hazards.

TI assumes no liability for applications assistance or customer product design. TI does not warrant or represent that any license, either express or implied, is granted under any patent right, copyright, mask work right, or other intellectual property right of TI covering or relating to any combination, machine, or process in which such semiconductor products or services might be or are used. TI's publication of information regarding any third party's products or services does not constitute TI's approval, warranty or endorsement thereof.